



Zoning Made Easy

RULES OF THUMB FOR THE NON-ENGINEER INSTALLER



Bell & Gossett
a xylem brand

INTRODUCTION

The Zoning Opportunity

Have you ever stopped to think about the business you're in?

Now hang on a minute. Before you say, "I'm in the heating business;" stop and think because a large part of your success lies in how you define your services to the public.

Think about it. Aren't you actually in the "Comfort" business?

Aren't your most satisfied customers - those folks who recommend you to their friends - the ones who are simply comfortable.

If the sun ducks behind the clouds on a January afternoon and the wind starts to howl, they're comfortable. If Mom turns the oven up high to cook a roast, they're not hot. They're comfortable.

If they like to sleep in a cool room but worry about the baby catching cold, they can adjust the temperature in each room to just the right point - so that everyone can be comfortable.

They can do this because you zoned their heating system.

Zoning provides comfort and fuel savings. And for those of us in the "Comfort Business," zoning provides a tremendous opportunity.

We wrote "Zoning Made Easy" to help you, the non-engineer installer, build your business. We want to make it easier for you to take advantage of the zoning opportunity.

"Zoning Made Easy" helps you get the job done quickly with a bare minimum of calculations.

We don't think that simple zoning has to be complicated. We've gathered up key "**Rules of Thumb**" that have served the old-timers well for many years. These Tricks of the Trade will help you figure that next zoning job in no time at all.

We'll show you:

- How to "rough estimate" a zoning job.
- How to tell how much heat a pipe will carry.
- How to know how much baseboard you can use in a single loop.
- How to figure how many convectors a pipe will serve.
- How to tell how many zone valves a circulator can handle.
- How to size circulators for single or multiple zones.
- How to handle the new generation of zoned domestic water storage tanks.
- How to add a radiant panel zone by getting two water temperatures from one boiler.
- How to run a hot water zone (up as high as the third floor!) by using the water in a steam boiler.
- And how to use the Bell & Gossett image of quality and service to build your business.

And that's not all. You'll find your Bell & Gossett Representatives seasoned professionals who are ready to help with all your questions. They're in the business of building your business. Why not take advantage of their years of field experience by calling them before you do your next job.

And when you call, be sure to ask them about the other "Made Easy" seminars.

Now listen up. Opportunity is knocking!

CONTENTS

The Zoning Opportunity	2
How Heat Travels	3
Zoning with Circulators	9
Zoning with Electric Valves	13
Zoning with Two Temperatures	18
Zoning with Condensate	19
The Bell & Gossett Advantage	20
"Rules of Thumb"	21

How Heat Travels (And how it knows where to go)

You've probably heard the terms "Flow Rate" and "Pump Head" used many times, but since these things can't actually be seen or touched in a heating system, you may not pay much attention to them.

But "Flow Rate" and "Pump Head" are more than just invisible concepts. They're real, they're important, and they can make or break your zoning jobs. Getting a handle on them sure makes the sizing and the troubleshooting go a lot smoother.

Flow Rate, Pump Head - this stuff doesn't have to be dull. Let's see if we can make it come to life.

Flow Rate - The "Train" That Heat Travels On

Back in the early 1800s when people first began to put central heat in their homes, an English man named Thomas Tredgold wrote a book called, "Heating and Ventilating of Buildings". In it, Tredgold defined a new term: the British Thermal Unit.

He figured this new heating industry couldn't go far unless it had a way to measure heat loss from buildings and heat output from radiators and boilers.

Tredgold decided that one Btu would be the amount of heat it took to raise the temperature of one pound of water (that's about a pint), 1°F. As time went by, everyone agreed this was a good term and accepted it for heating work.

Today, when you install a boiler rated at, say, 125,000 Btuh (British thermal units per hour) you're working with Tredgold's term. That boiler of yours has the ability to put 125,000 Btus of heat into the building over a period of 1 hour.

Where it goes, however, depends on a number of things. Zoning is one of them. But before we can get the heat out to the zones, we first have to get the water out of the boiler.

And that's where Flow Rate comes in.

You'll use a circulator to move the hot water from the boiler to the radiators. The flow rate of water created by the circulator determines how quickly the heat moves. You see, heat travels like a commuter on the flow. It gets on in the boiler and hops off in the radiators.

The trick is in making the right amount of it go where it's needed. That's what zoning is all about.

Most heating systems are designed to work with a 20°F temperature drop. This means that if the water leaves the boiler at, say, 190°F, it will return from the radiators at 170°F. Sometimes this drop in temperature is called "Delta-T." Delta is the Greek letter "D" which, in this case, stands for "Difference in." So a "20°F Delta T" would mean that the water left the boiler at a certain temperature and returned from the radiators 20°F cooler.

Flow Rate has a big effect on temperature difference. The faster the water moves, the less the temperature drop will be. That makes sense, doesn't it? The water isn't out there that long so it has less opportunity to drop off its heat.

Now look at it the other way. The slower the water moves, the bigger the temperature drop will be. Again, that makes sense because the longer the water is out in the system, the more chance it has to dump off its heat. But we don't want to keep it out there too long, do we? If we let it get too cool, it won't do any heating.

Traditionally, heating people have designed around a 20°F temperature drop. Why? Well, because a 20°F temperature drop makes the arithmetic easy.

Here, watch: To get from a Net Heating Load to a Flow Rate in gallons per minute when you're sizing a system for a 20°F temperature drop, all you have to do is divide the Net Heating Load by 10,000. Just like this, for example.

$$\frac{125,000 \text{ Btuh}}{10,000} = 12.5 \text{ gpm flow rate}$$

Twelve-and-a-half gallons per minute. There's your required flow rate for a 125,000 Btuh boiler. If you wanted to move water out of a 200,000 Btuh boiler, you'd use a 20 gpm circulator. Get it?

Suppose the boiler was sized for 150,000 Btuh? That would be 15 gpm. Easy, isn't it? That's why it's so popular.

This neat formula goes back to Tredgold's definition of a British Thermal Unit. Remember? One Btu is the amount of heat it takes to raise one pound of water one degree Fahrenheit.

The magic number, "10,000," comes from multiplying the weight of a gallon of water, which is 8.33 pounds, by the amount of minutes in an hour (because we're talking about a boiler rating in Btus per hour), by the 20°F temperature drop across the system.

So,

$$8.33 \times 60 \times 20 = 9,996$$

"Ten thousand" is close enough. Besides, it's easier to remember, and it sure is easy to use. And that brings us to our first **"Rule of Thumb."**

System Flow Rate "Rule of Thumb"

When You Want To Know Flow Rate Based on a 20°F Temperature Drop Across the System, Just Divide the Net Btuh Boiler Load by 10,000.

Now since Flow Rate is the "train" that heat travels on, the next question we have to ask is, What size pipe do we need to transfer a given flow?

To answer this, we look at pipe-sizing charts which tell us how much water we can safely fit through a pipe without creating velocity noise.

Velocity noise is the sound water makes in a heating system when it moves too quickly. You hear velocity noise in plumbing pipes all the time. No one seems to mind that, though. It goes away when you shut the faucet. Velocity noise in a heating system, however, isn't as easy to put up with.

If you've worked with zone valves, you may have heard velocity noise. You'll sometimes get it in a poorly designed system when all but one of the zone valves close and the circulator tries to push its entire load through that one remaining valve.

It just won't fit but that doesn't stop the circulator from trying! If it's the wrong circulator for the job, the pressure it creates will build and build and before you know it, you'll have a noise callback on that job. It's a tough one to explain to a homeowner. All he knows is that he didn't have it before you got involved in the job.

We'll show you how to avoid velocity noise later on in this booklet but for now, let's get back to this pipe sizing business.

You can move just so much water through a pipe without creating noise. That's pure physics, and it's also common sense when you stop to think about it. Let's face it, if you try to get ten pounds in a five-pound bag, you're going to lose.

It's like traffic. You can fit just so many cars on the road. Highways (big pipes) can take more flow (cars) than country roads (little pipes). How's that for an analogy?

We can look at pipes and, based on safe, noise-free velocities, come up with a useful "Rule of Thumb". This one will tell us how many gallons per minute we can expect to move through a pipe of a given size. And by multiplying that flow rate by 10,000 we can tell how much heat that flow will carry. That's what's really important, isn't it?

Maximum Flow Rate & Heat Carrying Capacity "Rule of Thumb"

Pipe Size (Copper)	Maximum Flow Rate	Heat Carrying Capacity
1/2"	1 1/2 gpm	15,000 Btuh
3/4"	4 gpm	40,000 Btuh
1"	8 gpm	80,000 Btuh
1 1/4"	14 gpm	140,000 Btuh

(*Based on a 20°F temperature drop across the system.)

Now let's imagine we're sizing a job and we decide to run a 3/4" series loop to each zone. Our "Rule of Thumb" tells us that each zone can carry about 40,000 Btuh. So how many feet of baseboard can we run?

Well, if you look in a baseboard catalog you'll see that, with an average water temperature of 180°F (that's pretty standard), each linear foot of baseboard will give off about 600 Btuh. If we set the boiler's high limit aquastat at 190°F and work with our 20°F temperature drop, we'll have an average temperature of 180°F across the zone. In other words, the first part of the baseboard will put out a bit more heat than the last part, but overall, things will balance out.

Knowing how much heat the pipe can carry, and how much heat each foot of baseboard will put into the room, all we have to do is divide 600 Btuh/foot into the 40,000 Btuh total carrying capacity of the 3/4" pipe to find the maximum length of baseboard we can use before we run out of useful heat.

In the case of 3/4", it's about 67 feet. Any run longer than that will be too cool at its end to do much heating. If you install more than that, you'll not only be wasting your money, you'll also have a real interesting troubleshooting call: The circulator is running but the end of the loop is cold. How come? You ran out of heat somewhere back up the road!

Most guys will troubleshoot this one as an air problem. Even though it isn't an air problem. They'll purge and purge until they drag hot water up from the boiler. They'll walk away with a satisfied smile thinking they've solved the problem. Unfortunately, the call bounces right back at them the next day.

This next "Rule of Thumb" will keep you from having this problem. And please keep in mind that this "Rule of Thumb" applies only to conventional fin tube baseboard radiation. It does not apply to the new, small-tube radiant baseboard.

Maximum Length of Fin Tube Base Board Loop "Rule of Thumb"

Pipe Size (Copper)	Typical Btuh Per Linear Foot	Maximum Length of Baseboard Loop
1/2"	600	25 feet
3/4"	600	67 feet
1"	770	104 feet
1 1/4"	790	177 feet

(*Based on 180°F average water temperature and a 20°F temperature drop across the system.)

So if the job has a run of, say, 100 feet, you'd better use at least 1" baseboard if you want the entire run to be hot. 3/4" will effectively "run out of heat" before it gets to the end and you'll have a real "head-scratcher" on your hands.

You could, of course, split the 3/4" loop into two parts, making sure that each part is no longer than 67 feet. Just be sure the common piping that supplies (or returns) the water to the split zone is at least 1" because the flow in that pipe will be double what it is in the baseboard. A split zone might look like this.

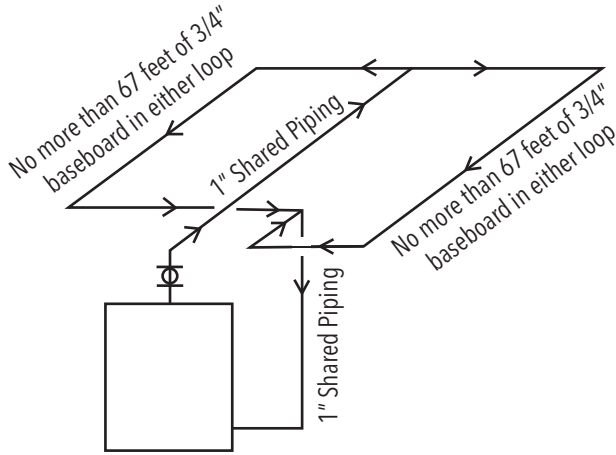

The Btuh/foot rating on 1/2" and 3/4" is the same, by the way, because the smaller pipe allows for more fin area. Notice, however, that the total allowable length of the run is much shorter with the 1/2" baseboard. That's because you get a lot less water through the 1/2" pipe.

Convectors

Convectors can be handled in a similar way. We know how much water we can reasonably move through a pipe of a given size. We thought about the typical convector you find in most houses and came up with another **"Rule of Thumb."**

The convector we usually see is 6" deep by 36" long by 24" high. (We also checked with a convector manufacturer. They told us that one was their biggest seller.) That 6" x 24" convector will put out about 5,100 Btuh when it's supplied with 180°F water. If we divide 5,100 into the maximum carrying capacity of a pipe, (Again, assuming the 20°F temperature drop) we can come up with the maximum amount of convectors it can serve.

Here goes:

Total Convectors a Pipe Can Serve "Rule of Thumb"*		
Pipe Size {Copper}	Maximum Btuh Capacity of Pipe	Total Convectors {6" x 36" x 24" 5,100 Btuh each}
1/2"	15,000	3
3/4"	40,000	8
1"	80,000	16
1 1/4"	140,000	27

(*Based on 180°F average water temperature and a 20°F temperature drop across the system.)

Of course, if you have larger or smaller convectors, you'll have to get the rating from the manufacturer's literature and divide it into the carrying capacity of the pipe. That will tell you how many you can use.

Stop for a minute here and look at the chart again. See how a 1" main can handle up to 16 convectors? We've visited many homes that have a 1" main serving about 10 convectors. Can you see why? A 3/4" line is too small, but the house doesn't need any more than 10 convectors.

That "excess" size in the pipe often comes in handy on these jobs, though, because many of these jobs use Monoflo® fittings. Monoflo fittings offer more resistance to flow than straight pipe. Without knowing it, we use the "extra room" in the pipe to keep the required pump head down.

We'll get to that in a just little while, but first, can you see how you can have system problems if the pipe going out to a zone isn't the right size?

Always remember that flow is the "train" that heat travels on. If the train is too small, the heat isn't going to get where you want it to go.

It's as simple as that. Bigger circulators with higher Pump Heads won't help you because you simply can't get 10 pounds in a 5 pound bag. Heat travels on flow, not head.

Pump Head - It has nothing to do with the height of the building!

We see it happen over and over again. Somebody looks at a three-story building and decides they need a circulator with a 30 foot head. How come? Because it's 30 feet from the basement to the top of the building.

Boy, are they sorry afterwards! That circulator is probably going to be much too big for the building it serves. And the velocity noise coming out of that oversized circulator is going to be incredible. Most of the time, you can hear it as you drive up to the building! The term "Pump Head" has nothing to do with height. It has to do with the circulator's ability to overcome the friction that's created when water flows through a pipe. We know it has nothing to do with height because this is a closed system that's completely filled with water.

If you're having trouble with the concept, think about it this way: As the water goes up, it also comes down. Those two forces cancel each other out. There's no lifting going on here. That's why "Head" has nothing to do with height.

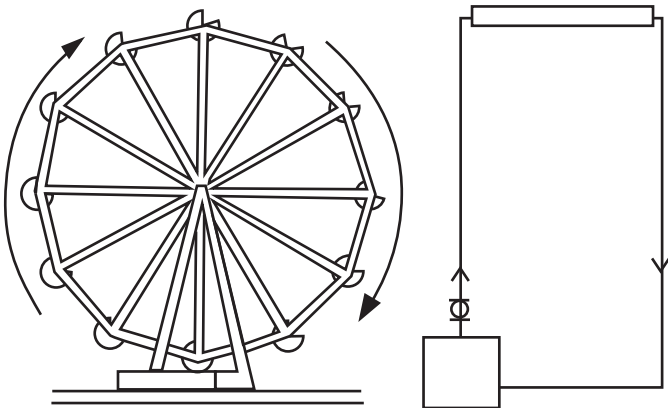

It's like a Ferris wheel. One car going up balances another car coming down. There's no lifting going on, is there? Nope, everything is in perfect balance.

All the motor on a Ferris wheel has to do is overcome the friction in the bearings and we're off and spinning.

The circulator in a heating system is like the motor on a Ferris wheel. All the circulator has to do is overcome the friction that's created when water rubs against the pipes. And that friction has nothing to do with height. In fact, we could take a 10 story building, size a circulator for it, knock the building over on its side, and we'd need the exact same circulator.

Pump head has to do with the friction caused by flow. That's it. And if flow is the train that heat travels on, head is the locomotive that drives the train.

We have to have a circulator with enough Head to move the Flow through the longest circuit. It's like saying that if the locomotive is powerful enough to make that long run, it will have no problem making the shorter runs when the time comes.

In other words, Pump Head is based on the worst case.

Let's look at an example. Here's a drawing of the heating system in a five-story apartment building.

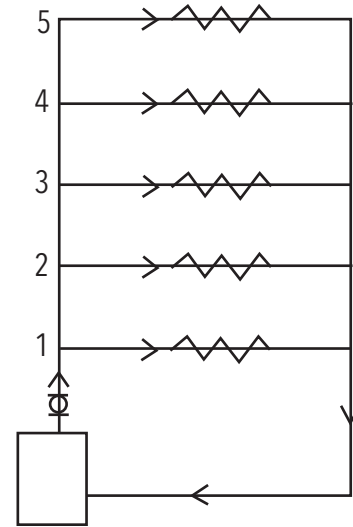

We call this a two-pipe, direct-return system. "Direct return" comes from the fact that the first radiator supplied with water is also the first radiator to return its water to the boiler. The water returns ... directly. Get it?

The system is set up like a ladder. The sides of the ladder are the supply and return mains; the rungs are the radiators. In this case, let's say the "rungs" are lengths of 3/4" baseboard.

The longest run in this building would be from the boiler to and through the baseboard on the fifth floor, and then back to the boiler. If the circulator can make that run, it will have no problem with any of the shorter runs.

Here, let's break the system up into parts to make that easier to swallow.

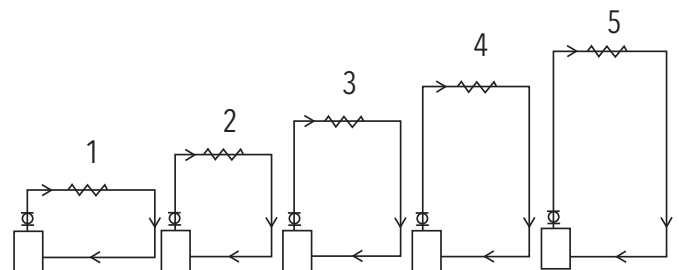

There you go. Can you see how a circulator strong enough to move water through Loop #5, will have no trouble with the other Loops? That's why we base Pump Head on that longest run. Sizing a pump for a higher Head than the system needs is a waste. Probably all you'll get for your efforts will be velocity noise from that oversized "locomotive."

Why look for trouble?

Finding the longest run in the building is fairly easy. In most cases, you just need to 'eyeball' the building. If you can't see the pipes, step outside and imagine what the longest run would look like. We can guarantee you this: It won't be higher, longer or wider than the building. So step out of the boiler room and look around.

Measure that longest run in feet and make a note of it.

Now there's one more thing we have to consider here. When water flows through a straight run of pipe, only the water on the outer edge of the flowing water touches the pipe.

But when that slug of water whips around a turn or splashes through a valve or other piece of equipment, the smooth flow gets all shook up.

We call this "turbulence." And when water gets turbulent, more of it comes in contact with the pipe, valves, and other gear.

Naturally, this increases the required Pump Head.

For example, you could go nearly nine feet in a straight run of 3/4" pipe with the same amount of Pump Head energy it takes to get through a 3/4" check valve. Or how about this: It takes the same amount of Pump-Head energy to move water through a 3/4" elbow as it does to go nearly four-and-a-half feet in a straight run of 3/4" pipe.

After a while, this extra friction adds up and we have to make allowances for it. But the problem is, you can't see all the fittings and valves, can you? Most of them are buried behind the walls. (Ah, there's nothing like the Real World to take the theory out of things!)

The way we've handled these "extras" over the years is to add an additional 50% to the straight-run piping. In most cases, that covers it.

So, if we measured the longest run and came up with, say, 200 feet, we'd add 50% (another 100 feet) and say the Total Equivalent Length of the pipe, for the purpose of sizing the circulator, was 300 feet.

Figuring Pump Head

So now that you've figured out your longest equivalent run, it's time for another "**Rule of Thumb**".

Up to this point we've sized everything based on "The Law of the Maximum." We want to get the maximum, trouble-free performance from the piping and components we select.

That makes sense, doesn't it? Let's get the job done correctly, and at the same time, economically. That's just plain good business.

So when we consider Flow, we size the pipes for the most water that will flow through them without giving us velocity noise. It makes no sense to oversize pipe; that only adds unnecessary expense to the job. And it makes no sense to undersize pipe either because then we'll get noise.

So, based on the maximum flow that will flow quietly through our piping, we came up with this next "**Rule of Thumb**."

Pump Head "Rule of Thumb"

If you're sizing the pipe for the maximum flow rate that will fit through the pipe without making velocity noise, the required pump head will be 4 feet for every 100 feet of total equivalent length.

So:

1. Measure the Longest Run in Feet
2. Add 50% To This
3. Multiply That By .04, and
4. That's the Pump Head!

In the example we were looking at before, we came up with a Total Equivalent Length of 300 feet (200 feet of actual run, plus 50%). Our "**Rule of Thumb**", tells us that the circulator we select for that job would have a Pump Head of 12 feet.

Get it? We're allowing four feet of Pump Head for every hundred feet of equivalent run. There are three hundred feet of equivalent run, so what we're doing is multiplying 4 (feet per hundred) x 3 (hundreds) to get 12 feet of Pump Head.

We saved an arithmetic step by using the .04 factor instead of dividing everything by 100 to get to feet of Pump Head.

Nothing to it!

Where the Flow Goes

By now, you should be getting the idea that pipe size has a lot to do with which way the flow will go. When you're zoning, you have to put in pipes that are large enough to carry the heat.

Of course, you can't tell how much heat a zone needs unless you do a heat loss calculation. Nowadays, a lot of guys don't put in that extra (but necessary) effort. They see it as too much trouble. They're in a hurry to get the job done.

So they take a chance on the Great Heating Lottery by guessing at how much heat the zone needs. Or they take the "safe" way out by running baseboard on every available inch of wall space.

The "safe" way doesn't make sense. Especially when you consider that if you're guessing at heat loss, you're probably going to install more radiation than you need. You might even lose the job because of your higher price!

But let's say you get the job. Why let the senseless practice of oversizing take money out of your pocket? We'd rather see you keep that money and wind up with a more comfortable customer.

Besides, calculating the heat loss isn't that the big deal nowadays. There are numerous sources of software available to help calculate the actual building heat loss. Spending a little extra time up front gathering the required information for this calculation will save you money all the way through the job.

So, if your zone pipes are sized to carry enough heat to match the heat loss in the zone, and if your radiation is sized to put the heat into the room once it arrives, you'll be in good shape.

Now, pipe size does control flow. But you have to remember that water is basically lazy and will always follow the path of least resistance. When you're zoning, it's a good idea to install things that will act sort of like traffic cops to direct the flow to the right place.

This is important because we could have four 3/4" baseboard loop zones running on zone valves from a single circulator. Each one of those zones can safely carry 4 gpm, or 40,000 Btuh. But they don't necessarily have to?

So how can you tell where the water (and the heat) will go?

Well, if all the zones are calling for heat, we'll bet that most of the water will go through the shortest zone because that's the easiest thing for water to do. (Remember, water is basically lazy.)

On zoned systems, we need something to control and direct the flow. This brings up a point that has to be made before we can go any further:

Flo-Control™ Valves Control Overheating, Not the Flow!

Maybe "Flo-Control" was a bad name to give to this device back in the old days when we were converting gravity hot-water systems to forced circulation. The industry needed something that would stop the hot water from rising up into the radiators when it wasn't needed. Hot water will do that, you know. It's lighter than cold water.

But the name Flo-Control valve makes some guys think they can balance a zoned system by turning the top levers on the valves. That's not what those levers are for.

Let's take a look inside one of these things and make sure we understand what its job is.

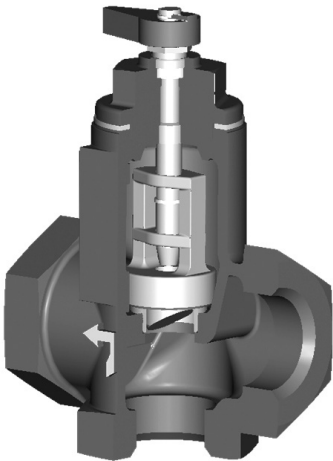

What we have inside is a brass weight that's loosely connected to a stem. The weight normally sits in the closed position and keeps the lighter hot water from rising out of the boiler when the circulator's off.

The circulator has no problem lifting this weight. As soon as it comes on, the force of the water just slides the weight right up the stem and out it goes to the radiators.

But then when the circulator shuts off, the weight inside the valve drops back down onto the seat. It won't allow hot water to rise out of the boiler unless the circulator comes on again.

In other words, it keeps the zone radiation from overheating. That's all.

The lever on top of the Flo-Control valve is there to give you a way to lift the weight up off the seat should the circulator fail and you want to get some temporary gravity circulation out to the zone.

You just crank the lever up; the stem rises and takes the weight with it. But that's all the lever does, it doesn't control the flow. You can't balance the flow through the zones by turning those levers. That's because Flo-Control valves control overheating, not flow.

For the Flo-Control valve to function properly, the lever must be installed in the top vertical position. At times, piping constraints won't allow this easily. That's why we decided to make the Hydrotrol® Flow Control Valves.



The Hydrotrol also only controls overheating, not flow. This valve is built with a spring loaded check and hand knob. The knob allows for manual valve bypass (like the lever on the Flo-Control valve) and can be installed in any position. No worries about piping issues.

Thermoflo Balancers® Do Control Flow

You can, however, balance the flow through the zones with Thermoflo Balancers. We'll take a look at how these work, but first, let's answer a more important question - Why would we want to use these things in the first place? Isn't life complicated enough without them?

Good questions.

We use Thermoflo Balancers to prevent what we like to think of as "Piping Rush Hour." That's what happens when too much flow tries to get onto a particular "road." Too much water flowing through a pipe causes velocity noise. And velocity noise causes service callbacks.

As we were saying before, our "Rules of Thumb" show us that we can move just so much water through a pipe of a given size without getting noise. A 3/4" pipe, for instance, can safely handle a maximum of 4 gpm.



But what about that system with the four 3/4" zones. Would each zone automatically get 4 gpm when the circulator kicked on?

Well, maybe. But then again, maybe not. It depends on where the system resistance is. Remember, the circulator is sized to overcome the resistance in the longest run. If it can do that, it will have no trouble with the shorter runs.

But what about this job with the four 3/4" zones. Some of those zones are longer than others, right? They have to be; and the circulator is sized for the longest zone.

So what's to prevent 6 gpm from whipping through one of those shorter zones? It could happen, you know. Water is lazy; it will always take the shortest route back to the boiler. And if too much water flows through the close-in zones, you'll get noise.

This is where the Thermoflo Balancers come in. These units have a glass tube that lets you see the Flow passing by. You can actually read the gallons per minute right off the scale. If the flow is more that it should be, all you have to do is throttle it by turning the built in balancing valve.

Thermoflo Balancers are like traffic cops. They prevent the Dreaded Piping Rush Hour. They make sure the flow goes where it's supposed to go. They let you see what's going on. They keep everything moving smoothly and in perfect balance.

The result? The house heats as it should, and you look real good.

Zoning with Circulators (First a Word on "Pumping Away.")

All the circulators shown in "Zoning Made Easy" pump away from the boiler and toward the system. We've put them there for a simple reason: Systems work better when the compression tank is connected to the suction side of the pump.

Heating engineers have known this for a long time. In fact, it's been a standard way to pipe large commercial jobs for at least 60 years.

The idea just never caught on with guys doing residential and small commercial piping. Probably because no one ever gave them a good reason to change. Let's face it, tradition is a strong motivator.

But now there is a good reason. Just look at all the changes that circulators have gone through over the past few years. These new circulators are smaller and they run at higher speeds and higher heads.

That makes a difference in the way the system operates. So much of a difference, in fact, that we see a brand-new opportunity for you.

You see, when a circulator pumps away from a compression tank, all the circulator's pressure appears as an increase out in the system. This sudden increase in pressure helps move air out of the radiators. Start-up becomes much easier, and, usually, there are fewer air related problems from that day on.

On the other hand, when you pump toward a compression tank (typically, when the pump is on the return side of the boiler), the circulator's pressure appears as a drop in pressure on the circulator's inlet side!

We've been talking about this phenomenon for years at our Little Red Schoolhouse in Morton Grove, Illinois. If you've ever piped a feed valve into the inlet side of a circulator on the return side of a boiler, you've seen this drop in pressure. The feed valve opens every time the circulator comes on. It can be a real problem.

This sudden drop in system pressure also makes it harder to get the air out of the radiators. System startup is tougher (especially on one-pipe systems with venturi-type fittings) and, in some cases, air can actually be sucked into the system through the air vents!

No one really noticed this problem when circulators such as the Series 100 were the only type available. But nowadays, many residential systems are using small, high-speed circulators such as NRF and ecocirc®.

These circulators, because of the higher heads they produce, can help you remove system air – if you install them pumping away from the compression tank and toward the system.

Or they can work against you.

When you install them pumping toward the compression tank they will drop the system pressure on their inlet side (as much as 6 psig!) every time they come on. That sudden drop in pressure will expand the trapped air bubbles up in the radiators, making it even more difficult to get air out of the system.

Have you ever noticed how it always seems to be those last couple of convectors, the ones closest to the return, that give you the biggest problem on start-up?

Now you know why.

Why not use this pressure phenomenon to your advantage? Pump the supply side. The system will work a lot better. In fact, we think you'll be amazed at the results. We say this even as we recognize that pumps installed on the return side have worked for years. They've even become a tradition over the years. Most of the drawings we've published over the years show the pumps on the return side and with the low-head pumps, this usually is not a problem.

But in light of today's high-head circulators, we've become convinced that your systems will work much better and start up a lot easier if you take this fresh approach of pumping away. It's good to question habit and tradition from time to time. Things change.

But let's get back to zoning.

One Zone - One Circulator

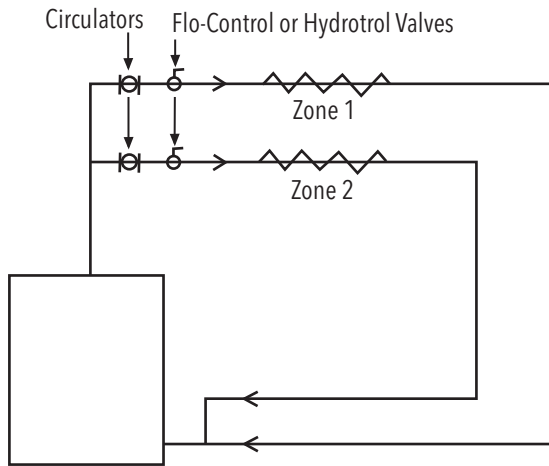

This is an easy way to get the job done. Each zone has its own circulator. You can set it up a couple of ways:

- The thermostat can turn the circulator on and off. In this case, the boiler would maintain temperature all the time. You use this method if the boiler has a tankless coil for domestic hot water.
- The thermostat can turn the circulator and the burner on and off at the same time.

You do it this way when you don't have a tankless coil. The only time the burner fires is when the zone thermostat calls for heat. Whenever you zone with circulators you have to use Flo-Control or Hydrotrol valves to prevent gravity circulation from an "On" zone into an "Off" zone. This is what Flo-Control or Hydrotrol valves do. Remember what we said before Flo-Control or Hydrotrol valves don't control the flow, but they do control overheating.

Sometimes you need Flo-Control or Hydrotrol valves on both the supply side and the return side when you zone with circulators. It all depends on how the system is piped.

You see, even if you have Flo-Control or Hydrotrol valves on the supply side, you can still get gravity circulation out the back end of a boiler. Gravity circulation doesn't need an entire piping loop to get started. All it takes is a hot area that's lower than a cold area. Remember, heat rises. And all it needs is one pipe.

So if you have, say, a first-floor radiator sitting directly above the return side of the boiler, you could get gravity circulation up to it. Even though there's a Flo-Control or Hydrotrol valves on the supply side.

The answer is to install a second Flo-Control or Hydrotrol valves on the return side. Just like this.

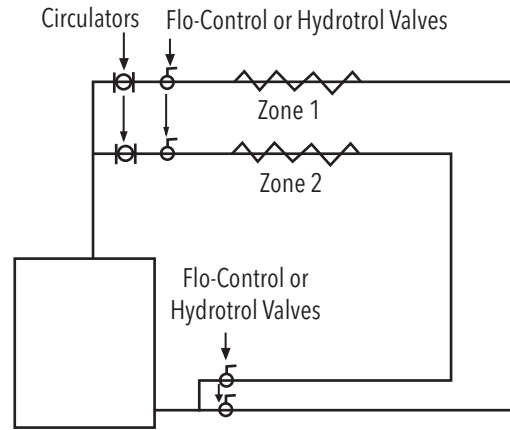
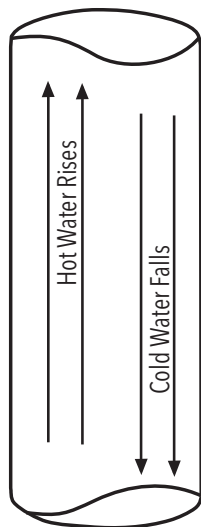

You won't have to do this on every job, of course, but if you get the problem of back-end zone heating, use the second Flo-Control or Hydrotrol valves and watch the problem disappear.

Shared Piping

Here's another important thing to consider when you zone with circulators. You have to make sure the piping that the circulators are going to share is big enough to accommodate the combined flow rate of all the circulators. (We have to get you thinking about highways again here.)

Say there are three 3/4" zones feeding back into a return manifold on a boiler. If each one of those 3/4" zones has 4 gpm flowing through it, the return manifold had better be able to accommodate 12 gpm. If it's too small, there's going to be a traffic jam in that common piping and the flow from all the zones is going to slow down.

That means you'll get less heat out to where the people are. It also means service callbacks.

So let's come up with another "Rule of Thumb" to help us stay out of trouble. This one will help us figure out what size the shared piping in a zoned system should be.

Shared Piping Size "Rule of Thumb"

Pipe Size	Maximum Flow Rate
1/2" copper	1 1/2 gpm
3/4" copper	4 gpm
1" copper	8 gpm
1 1/4" copper	14 gpm
1 1/2" copper	22 gpm
2" copper	45 gpm
1 1/4" iron pipe	17 gpm
1 1/2" iron pipe	25 gpm
2" iron pipe	50 gpm

RULE: Add up the flow from each zone and then find a "shared" pipe size that matches or exceeds the combined flow of all the zones.

For example, suppose we install a zoned system that has two loops of 3/4" baseboard, one for the first floor and another for the second floor. Each of these zones has a circulator.

The system also has one of these new zoned domestic-water storage tanks. This one requires a 1 1/4" supply pipe (It promises a quick recovery, so it needs a lot of heat in a hurry!) The zone with the tank also has a circulator.

So let's see what we have: Each 3/4" zone represents 4 gpm. That's 8 gpm. The storage tank has 1 1/4" copper tubing running to it. That means there will be a maximum of 14 gpm flowing that way.

When we add all the zones up, we see that we're going to have a maximum flow rate of 22 gpm in the shared piping.

So what size do we use?

Why either 1 1/2" copper tubing (22 gpm) or 1 1/2" iron pipe (25 gpm)! Isn't this easy?

We're showing you copper and iron in the larger sizes because supply and return manifolds can be installed either way and, as you can see, the flow rates are a bit different between copper and iron pipe.

Now you know why the supply and return tapings in the boiler are so big. That tapping is the Heating Expressway!

Picking the Right Circulator

When you're going to zone with circulators you have to decide which one to use. The larger the zone, the more water you'll have to circulate because, as you know by now, FLOW IS THE TRAIN THAT HEAT TRAVELS ON.

To help take the mumbo-jumbo out of zone-circulator sizing, we came up with this "Rule of Thumb."

Zone-Circulator Sizing "Rule of Thumb" For Heating Zones	
Zone Supply Pipe Size (Copper)	Bell & Gossett Circulator To Use**
1/2"	Series 100, NRF-9F/LW or ecocirc® 19-16
3/4"	Series 100, NRF-9F/LW or ecocirc 19-16
1"	Series 100, NRF-22 or ecocirc 19-16
1 1/4"***	Series HV or NRF-36

*Based on 180°F average water temperature and a 20°F temperature drop across the system.

**Assumption: Total zone piping 33% more than maximum baseboard radiation.

***You can use a Series 100, NRF-9F/LW, NRF-22 or ecocirc 19-16 on a domestic hot water storage tank with a 1 1/4" boiler supply tapping.)

How did we arrive at these selections? Well, we got the flow rate from the Maximum Flow Rate and Heat Carrying Capacity "Rule of Thumb." Then we based the pump head on the Pump Head "Rule of Thumb."

Since we don't know how long the longest run in the building is going to be, we made a few assumptions based on our field experience. We assumed the zone would be a baseboard loop. To get to and from the

radiation in that zone, we allowed 33% more piping than there is in the radiation portion of the zone. (Think about your last job. Wouldn't you say that's about right?)

In the case of the 3/4" loop (which would be 67 feet long, tops) we allowed an extra 22 feet of 3/4" pipe to get to and from the zone. That gave us a total run of 89 feet.

Then we allowed for an imaginary 50% more straight-run piping. Remember? That's so we'll have enough head to make it through all the fittings and valves. That's the Total Equivalent Length we talked about before.

We multiplied that Total Equivalent Length by .04 to get the maximum required pump head we can expect from that loop.

And then we picked the circulator that would get the job done without being oversized.

Notice how the 1 1/4" heating zone needs a Series HV or NRF-36? That's because the 1 1/4" zone can handle up to 14 gpm. We didn't want to use a Series 100 or ecocirc 19-16 on this zone because the 14 gpm flow rate is a bit more than they can be expected to move at the head pressures we need in that longer zone. The HV or NRF-36 are the right choice for this one.

For the 1 1/4" zone to the domestic hot water storage tank we use either a Series 100, NRF-9F/LW, NRF-22, or ecocirc 19-16 because the pressure drop is not as great as it is through a heating zone.

Piping a "Heating Module" to Increase Your Business

Once you get away from the traditional method of pumping back from the system you begin to open a whole new world of opportunity for yourself. Consider this. With the circulators on the supply side along with the air separator, expansion tank, pressure reducing or fill valve, flow-control valves, etc., you can now isolate the entire "Heating Module" between a couple of isolating valves.

Here's what a "Heating Module" looks like.

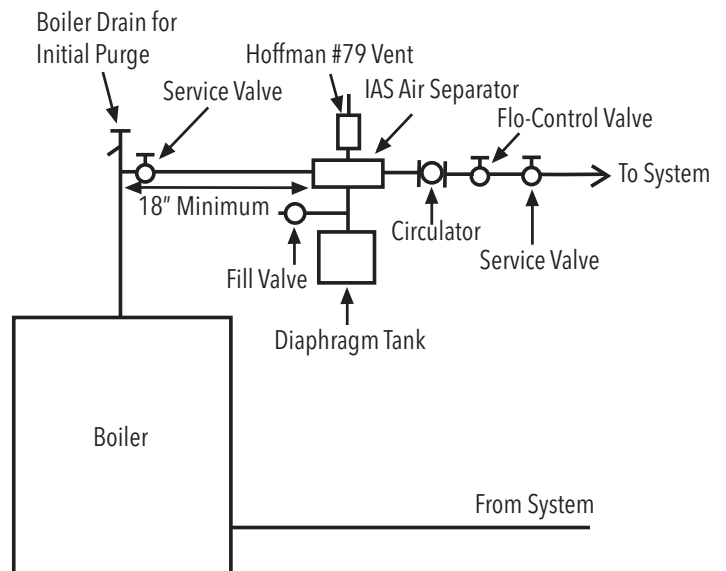

Look how easy this makes servicing any component. You just close a couple of valves. You get all the advantages of supply-side pumping and you can even prefabricate and test the entire module in your shop and then just connect it to a knocked down boiler. You already know how much space you have to work with because you saw the boiler room when you priced the job. Think about it. If they can prefabricate a house, why can't we prefabricate a boiler job? Besides, isn't it easier to work on a well-lit bench than in a boiler room?

Using the Heating Module also gives you a good story to tell the home owner when you're selling the job. Home owners are usually very receptive to the idea because a Heating Module is easy to service. And ease of service is to the home owner's advantage.

Tell him you won't have to go upstairs to vent his radiators because no water will escape from the system when you're making a repair. Not having to drain a system also cuts down on system corrosion. And the home owner won't lose a day's pay waiting for you to finish fixing his system; you're in and out in no time.

These are the benefits, the B&G benefits, you can now talk about when you're selling that "Heating Module" job.

You'll be surprised at how often this makes the difference between "No thanks" and "How soon can you start the job?" It sets you apart from your competition and makes you special.

Here's another plus: When you start-up a "Heating Module," all the system air is purged back to that one boiler drain installed in the supply-line heel tee. You just open the boiler drain, close the isolating valve in the boiler header and open the fast-fill valve. Watch how quickly the air gets pushed through the system. It comes right up from the bottom of the boiler and leaves through the heel-tee valve. What could be easier? Just think of how much time you'll save.

We know people who have doubled their boiler installation business by using this prefab method of piping. And they tell us the systems work better than any of the systems they installed the "old way."

The Heating Module is a great way to zone - with circulators or with zone valves.

Choices - Should You Zone with Circulators?

It costs a bit more to zone with circulators. It always has. Although the price of the small circulators is nearly the same as that of zone valves, you have to use a relay and a Flo-Control or Hydrotrol valves for each circulator. That may seem like a big disadvantage.

But there are also big advantages to zoning with circulators.

First of all, when you zone with circulators, you don't put all your eggs in one basket as you do with zone valves. If the circulator fails on a system using zone valves, you're basically out of business until the circulator is repaired. Oh sure, you could open the zone valves manually and get some gravity circulation to the zones, but it wouldn't be much.

But when you zone with circulators you're always going to have some heat. Even if one circulator goes down, you still have the rest up and running.

Another advantage is that each circulator is sized only to the flow requirements of one zone. In addition, zones with circulators can handle more flow than zones with zone valves.

Also, as you'll see, when we zone with valves, we have to size the circulator for the flow rate of *all* the zones. This can lead to a problem when just one zone valve is opened. If the circulator is not properly sized it can cause velocity noise.

You don't usually have velocity noise problems when you zone with circulators because the flow rate of the circulator is matched to the single zone, not to the entire system.

But, as we said, it does cost a bit more to zone with circulators. The choice, of course, is yours. But before you decide, let's take a look at how we zone with zone valves and see what Rules of Thumb we can come up with here.

Zoning with Electric Valves

Understanding the Concept

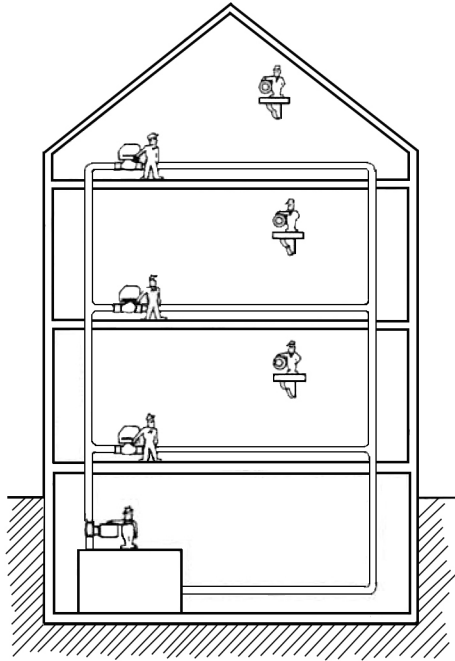

Picture this: You have 7 little men working together in a heating system. One of the guys is in charge of turning the circulator on and off. He's the low man on the totem pole; he takes orders (directly and indirectly) from everyone. We'll call him the Pumpman. The other guys, Heatmasters and Gate Keepers, are stationed throughout the system.

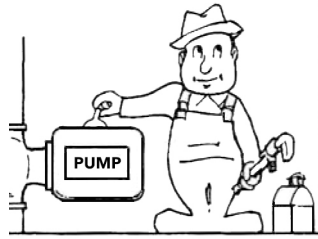

This particular house has three Heatmasters on the job. Each one is in charge of a different zone. They have tremendous responsibility. They sense the air temperature and determine how warm or how cool it should be in their zones.



The other three guys are in charge of opening and closing valves. These are the Gate Keepers. Gate Keepers are strictly middle management. They work for Heatmasters, but get to order the Pumpman around. When one of the Gate Keepers is told by a Heatmaster to open a valve, water will have access to that zone. But please understand that

it won't flow yet. It just has access to the zone. Nothing flows without ... Pumpman.

Okay, here's how all these guys work together. Let's say the Heatmaster on the first floor starts to get chilly. He shouts down to the Gate Keeper that he needs some heat. The Gate Keeper jumps to attention and opens his valve. Water now has access to the first-floor zone. But that's not making the Heatmaster happy. He's still cold because no water is flowing in his direction. He scowls.

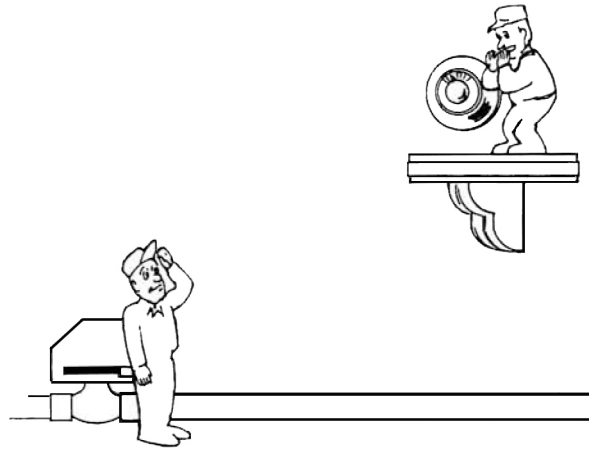
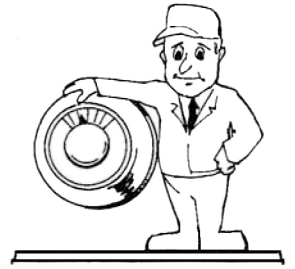

The Gate Keeper takes one look at the boss's face and, once the valve is fully opened, hollers over to the Pumpman to "Turn on the circulator!"

The Pumpman, of course, complies.



Now hot water flows out of the boiler, through the Gate Keeper's valve and up into the Heatmaster's zone. The temperature rises on the first floor and the Heatmaster smiles to himself and sits back. But before long, the Heatmaster begins to anticipate that



the temperature in the room will soon be too hot if the heat keeps coming up so he yells down to the Gate Keeper that enough is enough. "Shut it off!" he screams.

The Gate Keeper, wasting no time, shouts over to Pumpman that the Big Boss now has enough heat. "Shut off the circulator, I'm going to close the valve!" he says.

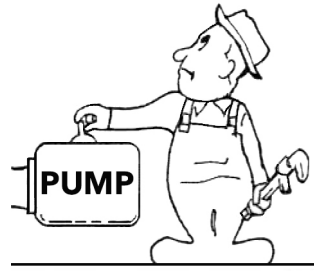

Now normally, Pumpman would shut off the circulator and the first floor Gate Keeper would then close the valve. But the Pumpman has more than one boss yelling at him on this job. Remember, there are three zones in this house. That means that at any given time, anyone of the three Gate Keepers could be ordering Pumpman to keep the circulator on.

And he has to listen to all of them.

The first-floor Gate Keeper understands this and, knowing there's nothing he can do about it, shuts his valve off anyway. After all, he doesn't want to get in a jam with his boss, the Heatmaster.

Sooner or later all three zone Heatmasters are warm and cozy so they each, in turn, order their Gate Keepers to "Shut it down." Naturally, they listen.

As the valves are closed, the Gate Keepers tell the Pumpman that now, finally, he can shut off the circulator and take a coffee break.

And that's pretty much how it works in the real world.

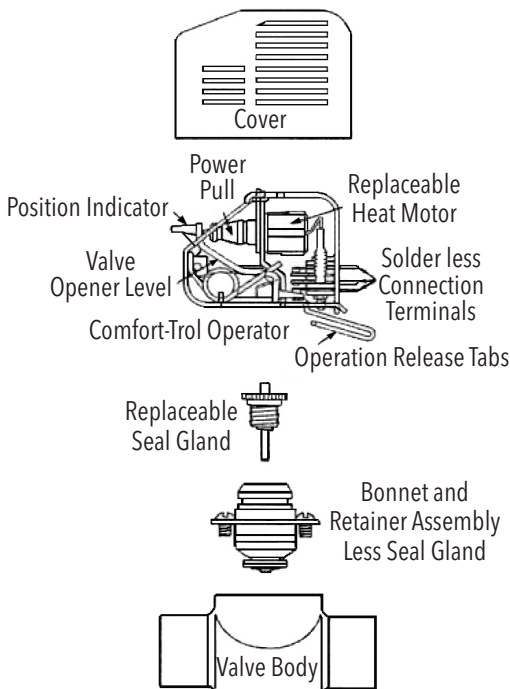

This is Bell & Gossett's Comfort-Trol® zone valve. It comes in two parts: the valve body and the operator.

The Comfort-Trol valve body is a spring loaded, normally open globe valve. Should you get a leak as the years go by, Comfort-Trol's valve stem can be replaced under system pressure (without having to drain the system) because of a special back seating valve disc. This feature can save you hours of labor.

The Comfort-Trol valve body can be installed either on the supply or return side of the system. It's up to you. Normal system temperatures won't bother Comfort-Trol (They'll take temperatures up to 240°F) so don't worry about putting them on the supply side.

In fact, we think it's best to pipe Comfort-Trol on the supply side, right after the circulator. That way, you can build a "Heating Module" with zone valves and have all the components between isolating valves.

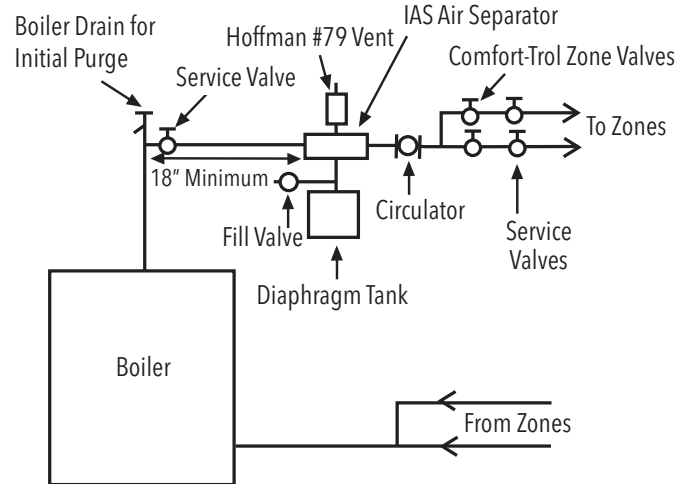

Our diagram shows what a 'Heating Module' with Comfort-Trol zone valves looks like.

And here's how Comfort-Trol works:

The thermostat calls for heat by sending an electrical "Go" signal to the zone valve operator. Inside the operator, the electricity flows through a normally closed switch and around a tightly wound coil we call a heat motor. This wire has high resistance; when the current flows through it, you get heat.

That's exactly what we want because the heat motor surrounds this bullet-like device we call a power pill.

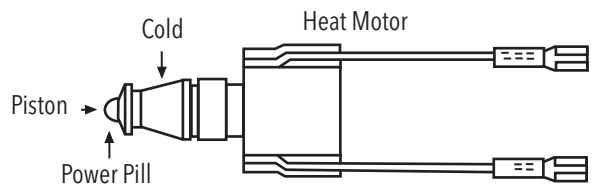

The power pill is filled with a temperature sensitive wax that expands when the heat from the heat motor hits it. As the wax expands, it pushes a piston out of the power pill.

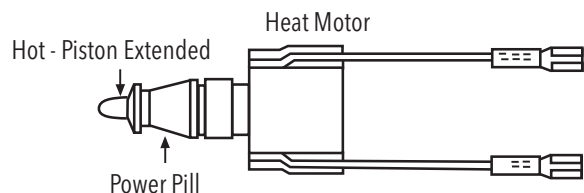

The piston pushes against the spring-loaded lever that normally holds the valve closed. This action lifts the valve disc off its seat and opens Comfort-Trol's valve.

Water now has access to the zone. But remember, nothing is flowing yet because the circulator (Pumpman!) hasn't yet been called on by the Comfort-Trol valve.

But that's about to happen. You see, the piston keeps pushing the lever forward until it trips an end switch.

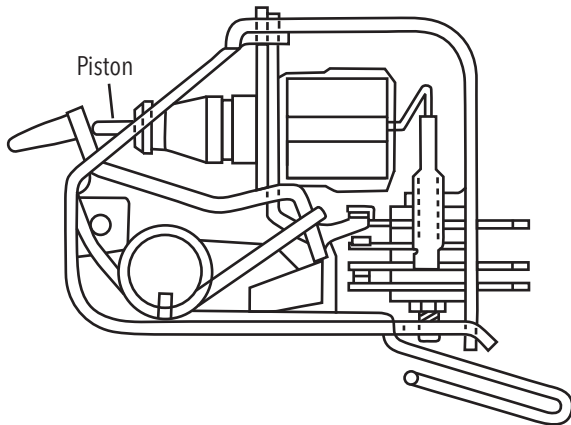

Value Open Auxiliary Switch Closed

The end switch makes a connection (through a relay) back to the circulator. The circulator instantly comes on and moves water through the Comfort-Trol valve and out to the radiators. (In systems without tankless coils or side-arm heaters, the end switch, working through the relay, would fire the burner at the same time it starts the circulator.)

Meanwhile, back at the Comfort-Trol valve, we have to have a way to shut the heat motor off so we let the piston stretch out just a bit further until it breaks the heat motor switch.

That switch cuts power to the heat motor and, almost immediately, the wax in the power pill begins to cool and shrink. Naturally, as that happens, the spring-loaded lever arm pushes the piston back into the power pill.

The circulator, however, is still running while this is going on because the end switch is still closed. The Comfort-Trol valve is still open, and hot water is still flowing out to the zone.

The piston slides back a bit, but just enough to allow that switch to close and send power to the heat motor again. The piston then goes back out again, the circulator continues to run, the zone continues to get heat.

Comfort-Trol's piston keeps sliding back and forth as long as the thermostat calls for heat. When the thermostat is finally satisfied, the power to the Comfort-Trol valve is cut. As the power pill cools, the piston is forced back by the spring-loaded lever arm. This breaks the end switch, sending a "Stop" signal to the circulator. Then the spring-loaded lever closes the Comfort-Trol valve.

Nothing to it!

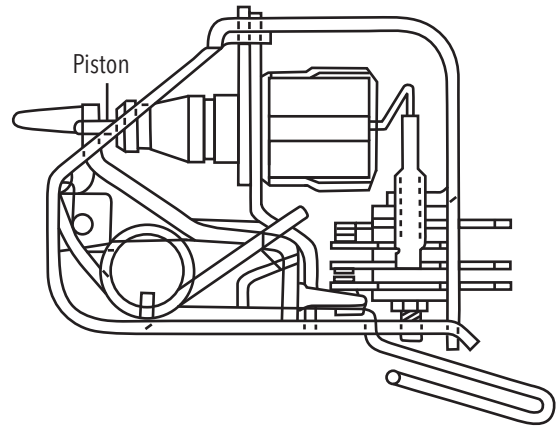

Value Open Auxiliary Switch Off

There are other types of zone valves on the market that work a bit differently than the Comfort-Trol. Some, for instance, use clock-type motors to open and close the valve. Others are power-driven open and power-driven closed.

We chose the heat motor design for our Comfort-Trol zone valve because we believe this gives you the best combination of small size and quiet operation.

We know that zone valves are often installed inside of the baseboard, right in the living space with your customer. Obviously, valve size and noise become very important when the valves are used in places such as this. We wanted something that would work anywhere you decide to use it. That's why we chose the heat motor design.

Comfort-Trol fits where others can't.

How to Size the Valves and the Circulator

Sizing Comfort-Trol zone valves is easy. They come in three sizes: 1/2", 3/4" and 1". All you have to do is go by the line size.

When you size the circulator, however, you have to consider a few more things. The circulator has to be able to supply flow to all the zones. That's different from what we had before when we were zoning with circulators. There, each circulator was only responsible for the flow in one zone.

However, now that we're using zone valves, we have just one circulator for the whole system. That circulator has to be able to move enough water to satisfy all the zones should they all decide to call for heat at the same time.

When we use zone valves, the amount of heat that can flow into a zone will be governed by the amount of water that can pass through the zone valve. That's because the valve is a restriction. It's like a doorway in a corridor. There's just so much water that can pass through under normal design conditions. Once again, "The Law of the Maximum" will let us know how much water that is. This flow, of course, determines the amount of heat that will flow out to the zone.

For instance, when we add a 3/4" zone valve to a 3/4" zone loop, we'll be figuring the flow at 3 gpm, not 4 gpm as we did when we were zoning with a circulator.

That's because of the additional pressure drop across the zone valve. That means we'll be able to move 30,000 Btuh instead of 40,000 Btuh out to that 3/4" zone. We have to take this into consideration when we're sizing the zone.

For 1" pipe, the maximum flow will be 4.75 gpm across the valve. Working with our standard 20°F temperature drop, that 4.75 gpm will give us 47,500 Btuh. Again, we must take this into consideration when we're laying out the system.

A 1" zone valve will also govern the amount of water that can flow to a domestic water storage tank that's tapped for 1 1/4" pipe. This restricted flow will increase the heater's recovery time. In many cases this isn't critical, but if you're not able to live with this longer recovery time, zone the storage tank with a Circulator instead of a zone valve.

Heating zones that use 1/2" tubing and 1/2" baseboard work on a maximum flow rate of 1 1/2' gpm and are limited to about 25 feet of effective baseboard. This small flow and short run creates less of a pressure drop across the zone valve. Because of this, there's no noticeable difference between zoning with a circulator or zoning with a zone valve on a 1/2" loop. So for the purpose of our **"Rule of Thumb"**, we not going to consider 1/2" pipe.

Nor will we consider 1 1/4" baseboard in our **"Rule of Thumb"** because this larger size is used almost exclusively on commercial jobs and is typically zoned with a circulator.

That leaves us with 3/4" and 1" and our next **"Rule of Thumb."**

Circulator Sizing "Rule of Thumb" for Systems with Zone Valves

1. Series 100, NRF-22, NRF-25, or ecocirc 19-16 can be used with:
 - a. Up to three 3/4" heating zones or
 - b. Two 3/4" heating zones and one 1" zoned domestic water storage tank.
2. Series 100, NRF-22, or NRF-25 can be used with:
 - a. Up to five 3/4" heating zones or
 - b. Three 3/4" heating zones and one 1" zoned domestic water storage tank.

Of course, if you have a system with a lot of zone valves you could break it up into parts. For instance, suppose you were working in a big house and the owner wanted ten zones. Each zone was going to be a 3/4" loop system with a zone valve.

Our **"Rule of Thumb"**, tells us to expect a maximum flow rate of 30 gpm in that system (Ten 3/4" zones X 3 gpm per zone = 30 gpm total system flow rate). So we would split the ten zones in half and use two Series 100's to satisfy the entire job.

If we were to use two ecocirc 19-16's instead of the Series 100's in this case we wouldn't be able to heat the house should all the zones call at the same time. The Series 100's would be the right choice because they have the flow capacity we need.

We remember troubleshooting a job not too long ago that had fifteen zone valves and the wrong circulator. One particularly cold day, all fifteen zones called at the same time. The circulator simply couldn't supply enough flow.

The service technician spent a few hours purging non-existent air out of the zones. He couldn't figure out what was going on. It just didn't occur to him that this circulator was too small to "deliver the goods" in a house this size. He didn't realize that Flow is the train that heat travels on. We divided the zones among several Series 100's and the problem was solved.

When it comes to circulators, one size doesn't fit all!

The Velocity - Noise Problem

When we zone with zone valves we have one circulator sized to meet the flow needs of all the zones. In other words, we're sizing for the worst case, the coldest day of the year.

But what happens when just one of the zone valves calls for heat? Where does all that extra water go?

Well, to answer this, we have to take a look at the way circulators move water. Let's take a look at a "pump curve."

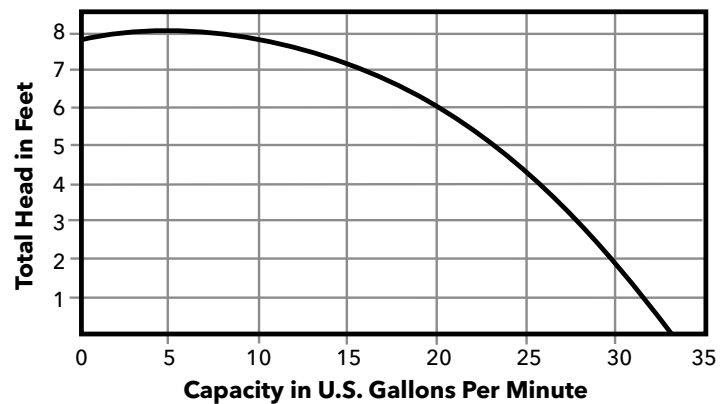

Bell & Gossett Series 100 Head Capacity Curve

This is the performance curve for the Series 100. It's sort of like a "fingerprint" for this particular circulator.

The bottom of the chart shows the flow rate in gallons per minute. The left side shows the pump head in feet (Remember, pump head is the circulator's ability to overcome resistance to flow). The curve running from the upper left to the lower right is the path on which the Series 100 operates. As you can see, the less resistance there is, the more water will flow.

This makes sense, doesn't it? It's like putting your thumb over the end of a garden hose. As you increase the resistance to flow with your thumb, the flow rate of the water will slow down. But it's sure hard to tell that you're getting less water, isn't it? Just look at the way it's coming out!

But guess what. The flow *has* decreased. It's the velocity that's increased. What you see coming out of that hose is less flow at a higher speed. This Flow Rate and Velocity business is a fine point in zoning that confuses a lot of people. Let's take a close look at it.

The flow rate is the amount of water that can move through a pipe in one minute. Flow rate is a measurement of quantity. That's why we call it "Gallons Per Minute." This is the "train" that carries the heat to the system.

Velocity is different; it has to do with speed. We measure velocity in "Feet Per Second."

It's sort of like the difference between the number of cars on the road and the speed at which they're moving. The number of cars would be the flow rate. The speed of the cars would be the velocity.

Let's say you were standing on the side of a six-lane super highway counting the cars as they went by. After a minute, you've counted 300 cars. They were moving at 55 m.p.h. because there's a radar trap just ahead.

Now just suppose you wanted those same 300 cars to flow down a one-lane country road in that same amount of time. They'd have to drive a lot faster, wouldn't they?

Back to heating.

Can you see how we could have the same flow of water moving at different velocities? It's like traffic. The same number of cars can go fast or slow.

Here, try this: Imagine 4 gpm moving through a 3/4" pipe. Those four gallons per minute will move at a speed of 2 1/2 feet per second in that pipe.

Now think about that same 4 gpm flowing into a 1 1/2" pipe. It's going to slow down, isn't it? Sure it is! The pipe is so much larger. There's room for the flowing water to spread out. In fact, in the 1 1/2" pipe, that 4 gpm will slow to about 8 inches per second.

But suppose we try to force the 4 gpm through a 1/2" pipe. What happens then? Suddenly the velocity increases to 5 1/2 feet per second because we're jamming it into a tight space. At this speed, the water is going to make noise.

That's what sometimes happens in a system that's zoned with valves. If you're not careful, you can get velocity noise when just one of the valves is opened. It all depends on the size of the piping and the circulator you're using. If the circulator is oversized, it will build a lot of pressure as it tries to slam-dunk the water through that single zone.

The result? You get a callback.

So don't oversize circulators. Use the ones in our **"Rule of Thumb"** and you'll be in good shape.

We believe the Series 100 is the best choice for zone valves because it has a very flat performance curve. Take another look at that curve. Can you see how the head pressure hardly rises at all as the flow slows from say, 25 gpm to 4 gpm? The Series 100 was designed for systems with zone valves. It has this remarkable ability to shed load without building much pressure. Not all circulators can do this.

If you're having problems with zone valves that whistle or bang when they close, try a Series 100 in place of the circulator you have in there now.

Watch how the problem disappears.

Velocity noise can also be an issue on large systems with numerous zone valves and a properly sized circulator. There will, after all, be times when only one or two zone valves are open and the circulator is operating at a reduced flow and higher head (remember the performance curve?). So we have to have some sort of bypass on this type of system to give water an additional place to go.

Many installers will leave a radiator out at the end of the run unzoned (usually a radiator in a hallway or lobby). That radiator becomes the bypass for the circulator as zone valves begin closing. But this often leads to velocity noise in that section of piping as the circulator's pressure builds and the water speeds up.

A better way to avoid noise is to install a differential bypass valve in the boiler room piping. It would go from the discharge side of the circulator back to the return side of the boiler.

Here's what one looks like.

A differential bypass valve senses what's going on in the system and opens and closes to compensate. When the zone valves are all open, the differential bypass valve is closed. As the zone valves begin to close, the differential bypass valve begins to open in proportion to what's happening out in the system.



So in effect, a differential bypass valve "nails" the circulator to a particular point along its performance curve. Velocity noise is never a problem when you use one of these devices.

Choices - Should You Zone with Electric Valves?

In general, zoning with electric valves is less expensive than zoning with circulators. That's because each circulator requires a relay and a flow-control valve. Zone valves don't need individual relays, they do, however, need a transformer.

Zone valves can be installed anywhere in the zone, even inside the radiator cover (This, of course, requires wiring over a longer distance which could be seen as a disadvantage). Zone valves take up less space and they weigh much less than circulators. These are good features if you're working in a tight space.

The drawback comes when you realize that you're depending on one circulator for the entire system. You have all your eggs in one basket and, should the circulator go down, you have no heat in the building.

Your customers could, of course, pop the heads off the zone valves should the circulator fail (Chances are he won't know enough to do this, though). Removing the operating heads opens the valves to gravity circulation. Your customer will get some heat while he waits for you to arrive and fix the circulator.

That one circulator also has to be sized for the entire flow requirement of the system so you could have problems with velocity noise if you don't match the right circulator to the system.

Also, the additional pressure drop of the zone valve means that we'll have less flow available to the radiators. That means that each zone would have to be somewhat shorter.

But if you take all of these factors into consideration when you're laying out the job, you'll find that electric zone valves work well and get the job done.

Zoning with Two Temperatures

When the GIs returned home from World War II there was a tremendous need for housing. Communities such as Levittown in Pennsylvania and on New York's Long Island sprung up almost overnight.

Many of these new homes had no basements. They were heated with radiant panels that were buried in the concrete slabs. The builder would have copper tubing laid out in a grid. The concrete guy would show up the next day and bury the pipes.

The boilers in many of these houses were in the kitchen. Right next to the refrigerator!

Now you have to understand that when you heat a house by running hot water through the floor there's a limit to how hot that water can be. Usually, if the temperature of the water in the radiant panel went above 140°F, the family cat would get stuck to the ceiling!

And yet, since the boiler was making hot water with a tankless coil, it had to maintain 180°F. This could have presented a real problem. But because the installers of those boilers knew how to pipe in a simple bypass to blend water from the boiler with water that had already been through the radiant panel, the 180°F boiler water didn't present a problem.

Those Old-timers would blend just the right amount of hot water into the cooler return water to get 140°F, degree supply temperature out to the panel. It didn't take a lot of complicated controls, just a piece of pipe.

Sometimes they used a special close nipple made just for this purpose. The nipple had a 1/8" tapping for the boiler water. That nipple would go in the return piping, right at the inlet to the boiler. It would divert water through a bypass and back out to the panel.

An Old-timer showed us one of these special nipples not too long ago. It was pretty chewed up. In fact, it looked like it had been removed from the boiler with a four-foot wrench.

"This is the difference between youth and experience," he told us. "You have to know this thing is in there before you can convert the system to baseboard. You have to know it's in there. And then you have to get it out!"

Radiant panels are making a comeback nowadays. Few people are using copper tubing anymore, most use flexible tubing made from space-age plastics.

But we still have to keep those panels at low temperature (usually 120°F) to keep the floor from overheating (Remember, the family cat?). The simplest way to do this is still with a bypass line. Here, take a look.

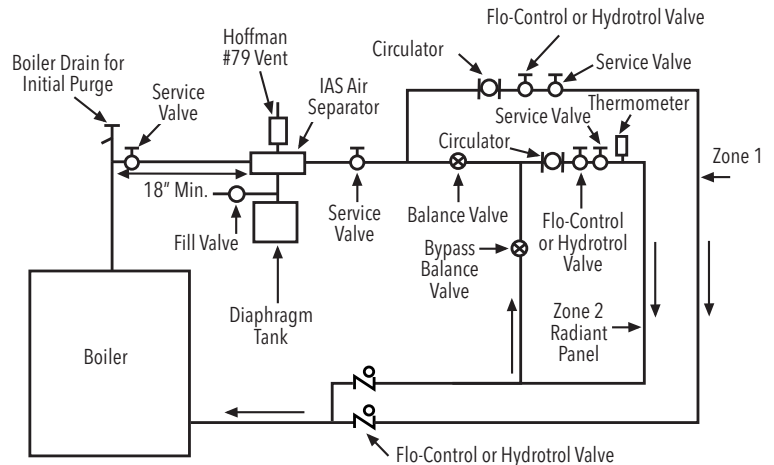

We use a full-size bypass line with a full-port balancing valve. We also have a thermometer on the discharge side of the circulator. When we start the zone circulator, all the system water will flow through the bypass because that's the path of least resistance.

To adjust the temperature in the panel, we run the boiler up to high limit and then throttle the full-port balance valve until the thermometer on the discharge side of the circulator reaches 120°F. Then we take the handle off the balance valve so the homeowner leaves it alone.

This method has traditionally worked well. It's simple and it's inexpensive. The drawback is that you're, setting it up for the worst case, the time when the boiler is operating at limit. Since the balance valve is a fixed opening, it has no way of adjusting to allow in more hot boiler water if the boiler temperature is below high-limit.

So we can get a bit more complicated and do it this way.

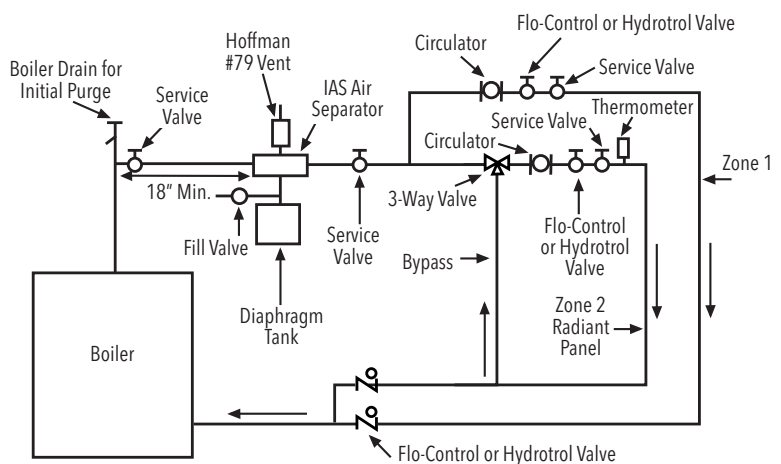

This is how commercial systems work. The 3-way valve senses what's flowing out to the system and adjusts the zone supply temperature as needed.

With this system, you'd run the circulator continuously and have the 3-way valve take orders from a room thermostat and a boiler aquastat working together as a team. Or, better yet, you could have the 3-way valve respond to an outdoor-air sensor. That way, as the day gets cooler, the water-supply temperature can get hotter, and vice versa. (This is not a good way to do it, however, if you have a tankless coil or a side-arm heater.)

On commercial jobs, this is called a "reset" system because the water temperature is always being re-set to meet the needs of the building at any given time.

Add a room thermostat in series with the reset control and you'll be able to compensate for the body heat that rises off a houseful of company.

Here's another way to do it.

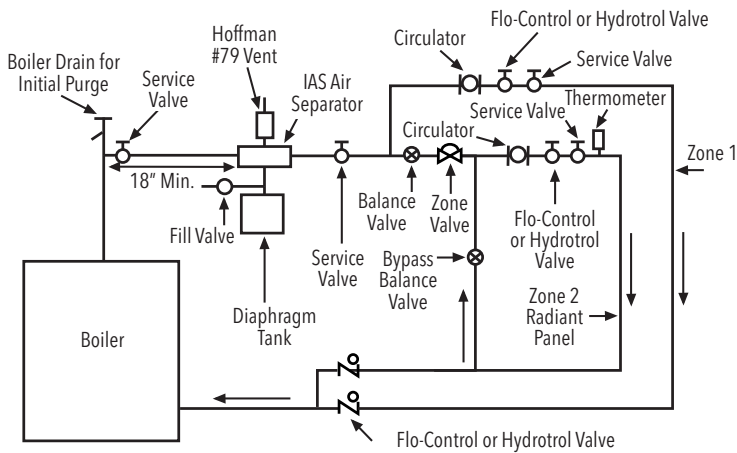

This does the same thing as the three way valve but it does it with a standard 2-way zone valve. The control sequence can be the same as what we talked about for the 3-way valve.

Zoning with Condensate

We could subtitle this, "Many Have Tried, But Few Have Succeeded." A lot of guys try to use the water below the boiler water line of a steam boiler to create a hot water zone. It's an inexpensive way to get the job done - and it can be done. But to do it correctly, you have to remember your high-school physics.

Pumping the water out of the boiler and through a loop of baseboard isn't so tough. As long as the loop runs around the basement floor, that is. But when you try to put that zone up on the first or second floor, well, that's when you can get into trouble.

But not if you know what you're doing. In fact, you can put a hot water zone on the third floor of a building - if you stop and think about what's going on.

First, you have to remember that water boils at 212°F at atmospheric pressure. Naturally, in a steam boiler, the water is usually hotter than that because it's under a few pounds of pressure. For instance, at two psig, water won't boil until it reaches 219°F.

Next point: In a closed hot water system we use the pressure reducing valve to keep the high point of the system under pressure. We set it up

so there's always at least 4 psig of water pressure inside the top floor radiator. That's to make sure the water inside that radiator won't boil under normal system conditions. You see, it's the pressure reducing valve that allows us to run hot water boilers at temperatures over 212°F. A boiler under 12 psig pressure, for instance, can operate at 244°F without having the water boil.

But when we pump condensate up to the first, second, or third floor of a building, the only thing providing pressure at the high point is the circulator. And when the circulator shuts off, the water in that top floor radiator will "flash" into steam if it's too hot.

"Flashing" is not only noisy, it's incredibly destructive. And the sudden expansion of the water into steam as the "flash" occurs will push all the water in the zone back down into the steam boiler and flood it.

There's a trick you can use to avoid this. It's a way to make sure the water in that top-floor radiator never gets so hot that it can flash to steam. We use a bypass line made from a length of 3/4" copper tubing and a full port balancing valve - just like we did on the hot-water job.

Here, take a look.

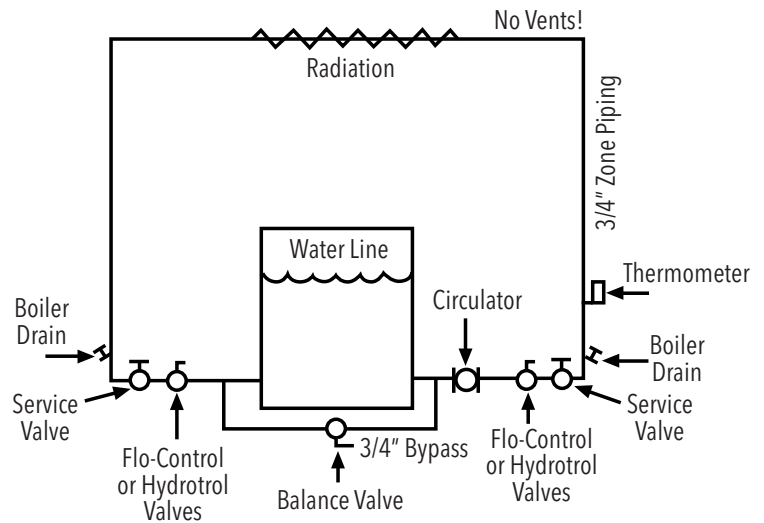

We run a continuous 3/4" loop from the boiler up through the baseboard on, say, the third floor. From there, it returns to a point on the opposite side of the boiler.

Naturally, both of those connections must be made below the boiler water line, as low as possible, but not in the mud leg. This system is much easier to pipe on a cast-iron boiler than it is on a steel boiler because there are more tappings on a cast-iron boiler.

Make sure there are no air vents, valves with packing glands or anything else that could allow air to enter the system when the circulator shuts off. And size the baseboard to the heat loss of the space with an average water temperature of 170°F. (The hottest water we'll ever have up there at the top will be 180°F.)

We fill the entire loop with a garden hose. Just hook it up to one of the two boiler drains on the system side of the two shut-off valves and purge all the loop's air through to the other boiler drain. When we get a solid stream of air-free water, we shut both boiler drains at the same time.

You see, we're not going to use the circulator to push the water up to the top of the loop. We don't have to. Water will stay in a 3/4" pipe that's about thirty feet high. As long as you don't let any air get in the top, that is. The water stays in that pipe for the same reason that soda will stay in a straw when you hold your finger over the top and lift it out of the glass.

The atmospheric pressure pushing down on the surface of the water in the boiler holds the water up in the pipe. It's like a barometer. As long as air can't get into the top of the pipe (no vents, please!) the water can't fall out.

So now all the circulator has to do is circulate, just like it does in a closed, pressurized system. We're not asking it to do any lifting so we don't have to use a high head circulator. And as long as the water temperature leaving the boiler stays below 180°F there's no way it can flash at the top.

We make sure it stays relatively cool at the top by installing the 3/4" bypass around the boiler. That line, with its 3/4" full-port balancing valve, becomes the path of least resistance for the water. It's easier for the water to go through the bypass than it is to go through the boiler. So when the circulator comes on, all the water will bypass the boiler and flow only through the loop.

Now all we have to do is make the water hot. We do that by slightly throttling the balancing valve until the thermometer on the discharge side of circulator hits 180°F. Of course, you have to do this when the steam pressure is up.

From that day on, the temperature on the discharge side of the circulator will never go above 180°F because the bypass will automatically blend water that's been through the system with water that's been through the boiler.

The B&G Flo-Control valves you see in the drawing are needed on both sides of the loop to prevent gravity circulation. And yes, you do need two of them because gravity circulation doesn't need an entire loop to happen. It just needs a single pipe! The hot will rise up the center of the pipe as the colder water falls down the sides.

The circulator should always discharge out of the boiler and toward the system. That's because circulators need a certain positive pressure at their suction side to prevent what's known as cavitation.

Simply put, cavitation is what happens when a circulator tries to throw out more water than it can take in. In this case, it can't take water in when the suction pressure is too low because the water is flashing into steam!

You should use an all-bronze Series 100 B&G circulator for this zoning application. Condensate is very corrosive. It's much too tough for a water-lubricated circulator. If you want this zoning job to last, use the right circulator.

Oh, another thing: Make sure the circulator is below the boiler water line. If the circulator is above that line, it will empty itself of water on start-up, drop its suction pressure below atmospheric, and flash whatever water's inside of itself. We once saw a circulator installed like this move six inches off center when it came on!

You control the circulator with a thermostat. If the boiler is maintaining temperature for a tankless coil or a side-arm heater there should always be enough heat in the boiler for the zone.

If the boiler fires on demand, however, you'll have to also add an aquastat to fire up to high-limit (180°F) when the thermostat calls in the circulator.

So install it right and you'll find it's a good, inexpensive way to add a zone to that old steam system.

The Bell & Gossett Advantage

How you decide to zone that next job is your choice. You may prefer circulators over zone valves. Or you may feel just the opposite. We realize that personal preference and experience play a large part in your decision.

But whichever way you decide to go, we don't think you have to be an engineer to get most residential and light-commercial zoning jobs done well. You just have to have a good basic grasp of what's going on in the system. And you have to be able to feel confident about what you're doing.

We've drawn from our years of field experience to bring you this booklet. We hope it helps to make you even more successful than you are now.

As you use these "**Rules of Thumb**" to save time when you're doing that next quote or to figure out what's wrong when you troubleshoot that next problem job, we hope you'll remember us by using our products. We think there's a tremendous advantage to working with people who can help you.

That's the B&G advantage. We can help you get the job done right.

Besides, your customers know us. Many of them have grown up with B&G equipment in their homes. They feel comfortable with B&G and they know, when they see that bright red color and the B&G logo, that you've given them the quality they expected.

We hope you'll use this booklet, and the other "Made Easy" booklets to your best advantage. We want you to know we appreciate the business you've given us, and we look forward to working with you on your next job!

Zoning Made Easy - "Rules of Thumb"

Flow Rate

$$\frac{\text{Net Btuh Load}}{10,000} = \text{Flow Rate}$$

Maximum Flow Rate

Pipe Size (Copper)	Maximum Flow Rate
1/2"	1 1/2 gpm
3/4"	4 gpm
1"	8 gpm
1 1/4"	14 gpm

Maximum Flow Rate & Heat Carrying Capacity

Pipe Size (Copper)	Maximum Flow Rate	Heat Carrying Capacity
1/2"	1 1/2 gpm	15,000 Btuh
3/4"	4 gpm	40,000 Btuh
1"	8 gpm	80,000 Btuh
1 1/4"	14 gpm	140,000 Btuh

(Based on 20°F temperature drop across the system)

Maximum Length of Fin-Tube Baseboard Loop

Baseboard Size (Copper)	Typical Btuh Per Linear Foot	Maximum Length of Baseboard Loop
1/2"	600	25 feet
3/4"	600	67 feet
1"	770	104 feet
1 1/4"	790	177 feet

(Based on 180°F average water temperature and a 20°F temperature drop across the system)

Total Convectors a Pipe Can Serve

Pipe Size (Copper)	Maximum Btuh Capacity of Pipe	Total Convectors (6"x36"x24" 5,100 Btuh each)
1/2"	15,000	3
3/4"	40,000	8
1"	80,000	16
1 1/4"	140,000	27

(Based on 180°F average water temperature and a 20°F temperature drop across the system)

Shared Piping Size

Pipe Size	Maximum Flow Rate
1/2" copper	1 1/2 gpm
3/4" copper	4 gpm
1" copper	8 gpm
1 1/4" copper	14 gpm
1 1/2" copper	22 gpm
2" copper	45 gpm
1 1/4" iron pipe	17 gpm
1 1/2" iron pipe	25 gpm
2" iron pipe	50 gpm

Zone-Circulator Sizing for Heating Zones*

Zone Supply Pipe Size (Copper)	Bell & Gossett Circulator To Use**
1/2"	Series 100, NRF-9F/LW or ecocirc 19-16
3/4"	Series 100, NRF-9F/LW or ecocirc 19-16
1"	Series 100, NRF-22 or ecocirc 19-16
1 1/4"***	Series HV or NRF-36

*Based on 180°F average water temperature and a 20°F temperature drop across the system.

**Assumption: Total zone piping 33% more than maximum baseboard radiation.

***You can use a Series 100, NRF-9F/LW, NRF-22 or ecocirc 19-16 on a domestic hot water storage tank with a 1 1/4" boiler supply tapping.)

Pump Head

1. Measure the longest run in feet
2. Add 50% to this.
3. Multiply that by .04 and
4. That's the pump head

Circulator Sizing for Systems with Zone Valves

1. Series 100, NRF-22, NRF-25, or ecocirc 19-16 can be used with:
 - a. Up to three 3/4" heating zones, or
 - b. Two 3/4" heating zones and one 1" zoned domestic water storage tank.
2. Series 100, NRF-22, or NRF-25 can be used with:
 - a. Up to five 3/4" heating zones, or
 - b. Three 3/4" heating zones and one 1" zoned domestic water storage tank.

Xylem |'zīləm|

- 1) The tissue in plants that brings water upward from the roots;
- 2) a leading global water technology company.

We're a global team unified in a common purpose: creating advanced technology solutions to the world's water challenges. Developing new technologies that will improve the way water is used, conserved, and re-used in the future is central to our work. Our products and services move, treat, analyze, monitor and return water to the environment, in public utility, industrial, residential and commercial building services settings. Xylem also provides a leading portfolio of smart metering, network technologies and advanced analytics solutions for water, electric and gas utilities. In more than 150 countries, we have strong, long-standing relationships with customers who know us for our powerful combination of leading product brands and applications expertise with a strong focus on developing comprehensive, sustainable solutions.

For more information on how Xylem can help you, go to www.xylem.com



Xylem Inc.
8200 N. Austin Avenue
Morton Grove, Illinois 60053
Phone: (847) 966-3700
Fax: (847) 965-8379
www.xylem.com/bellgossett