



# A Reference Guide to Building in Glens Ferry & Elmore County

(Based on the 2017 Idaho Residential Code)

Elmore County Land Use and Building Department  
520 East 2<sup>nd</sup> South St., Mountain Home, ID 83647  
(208) 587-2142 ext. 502 or (208) 587-2120 Fax

[www.elmorecounty.org](http://www.elmorecounty.org)

Glens Ferry Building Department  
110 E 2<sup>nd</sup>, PO Box 910, Glens Ferry, ID 83623  
(208) 366-7418 ext. 8 or (208) 366-2238 Fax

[www.glensferryidaho.org](http://www.glensferryidaho.org)



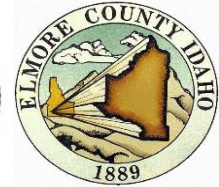

This reference guide is intended to assist the building novice and the expert builder as well. Our hope is that we have provided a comprehensive guide to be used as a useful reference for your building projects. You may have questions, in which case, please contact us. We will be glad to assist you and answer your questions.

Elmore County Land Use and Building Department is located across the street from the War Memorial Hall (American Legion). Our address is 520 East 2<sup>nd</sup> South St., Mountain Home, ID 83647

Our hours of operation are Monday through Friday from 8:00 AM to 5:00 PM (excluding Holidays).

Phone number is (208) 587-2142 Ext. 502 or Fax number is (208) 587-2120.

Our website is [elmorecounty.org/land-use-and-building-department/](http://elmorecounty.org/land-use-and-building-department/)

All Electrical, Plumbing and HVAC applications and inspections are administered by the State of Idaho, Building and Safety Division, the phone number is (208)334-3950 for additional information.

Call Digline before you dig.  
1-800-424-5555

Glenns Ferry Building Department is located at Glenns Ferry City Hall

110 East 2nd Avenue, Glenns Ferry, Idaho

Hours of Operation: Monday-Thursday 7-5:30 pm.

Lori Freeman - Planning & Zoning Administrator

(208) 366-7418 Ext. 7

Vance Pruett - Building Inspector

(208) 599-4460

**This document was copied from the Elmore County Land Use and Building Department for use in the City of Glenns Ferry.**



# Table of Contents

<u>Topic</u>	<u>Page Number</u>
Permits—When Required	4
Basic Stairs	5
Guards (stair)	7
Handrails	8
Smoke Alarms/Carbon Monoxide	9
Basic Decks	11
Garage Separation	14
Residential Emergency Escape & Rescue Openings	15
Notching and Boring Rafter/Joists/Studs	17
Fire Protection of Horizontal Venting	20
Safety Glazing	21
Typical Wall Framing	27
Site Plan Example	29
Footings	31
Sample Plan	32



# Elmore County Land Use and Building Department

## When are Building Permits Required?

---

Common examples of when a permit is **required**:

- Permanent Carports (steel carports require design engineering)
- Decks more than 200 square feet and 30" above grade
- Exterior doors and windows
- Fireplaces, Woodburning stoves and inserts
- Garage conversions
- Sidewalk or driveways
- Guest home
- Fences **over** 7 feet high
- Retaining walls **over** 4 feet high
- In-ground or above, swimming pools and swim spas 4 feet deep or above ground prefabricated pools over 5,000 gallons
- Any structure over 200 square feet and/or is attached to another structure or living space
- Residential solar panels (roof mount and ground mount)

Common examples of when a permit is **not required**:

- **Nonpermanent Storage** shed **less than** 200 square Feet
- Fences **under** 7 feet high
- Retaining wall **under** 4 feet high
- Replacement decking without replacement of structural members
- Painting, siding, tiling, carpeting and similar finish work
- Bathroom, kitchen, dishwasher, ovens, washer, dryer replacements without modification to gas, plumbing or electrical
- Swings, slides and other playground equipment
- Window awning supported by outside wall
- Portable pools under 5,000 gallons
- Flag poles



# Basic Residential Stairs

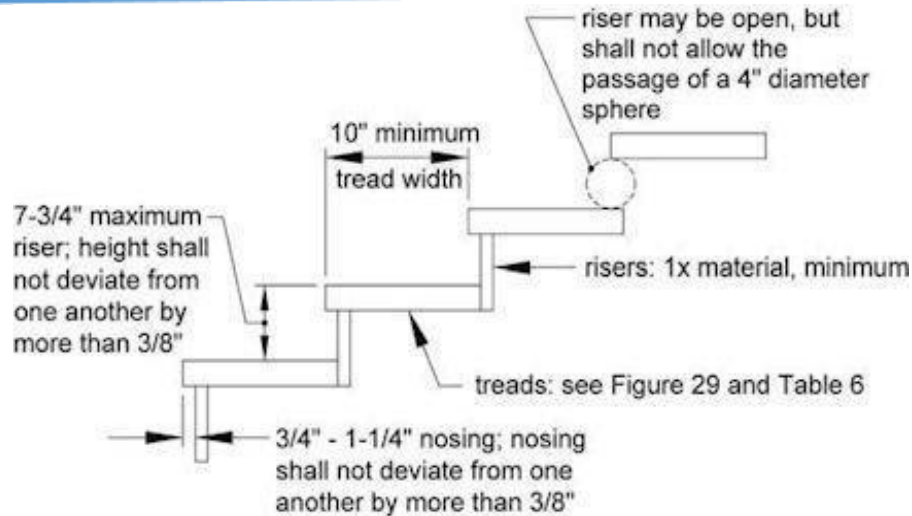

## Typical Stair Section R311.7

### NOTES:

1. These regulations apply to stairways for one and two-family dwellings and townhouses subject to the 2012 International Residential Code (IRC). Refer to the 2012 International Building Code for requirements for stairs in other conditions.
2. For construction of circular, spiral or winding stairways, see R311.7.10.
3. The largest rise or run within any flight of stairs is not to exceed the smallest by more than 3/8".
4. A landing extending the width of the stair and measuring a minimum of 36" in the direction of travel is required at the top and bottom of every stairway.
5. A floor landing is not required at the top of an interior flight of stairs, provided a door does not swing over the stairs.
6. Handrails are required for stairways with four or more risers. See Tip sheet 6 for handrails.
7. Interior and exterior stairs must be illuminated with a n artificial light source at each landing or over each stairway section per R303.6. Light activation must be accessible at the top and bottom of each landing without traversing any steps. Exterior stairways must be controlled from inside the dwelling unit unless continuously illuminated or automatically controlled.

### General Information:

1. Consult with the Building Department regarding required setbacks.
2. Obtain a building permit before starting construction.
3. The intent of this sheet is to address the basics of private residential stair construction ONLY and does not address the subject in great detail. Additional information can be found at your local building department, home improvement store, or library.
4. This tip sheet is intended to show code requirements per the 2012 International Residential Code.

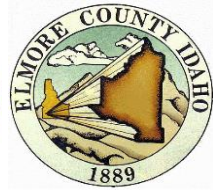

# Basic Residential Stairs (cont'd)

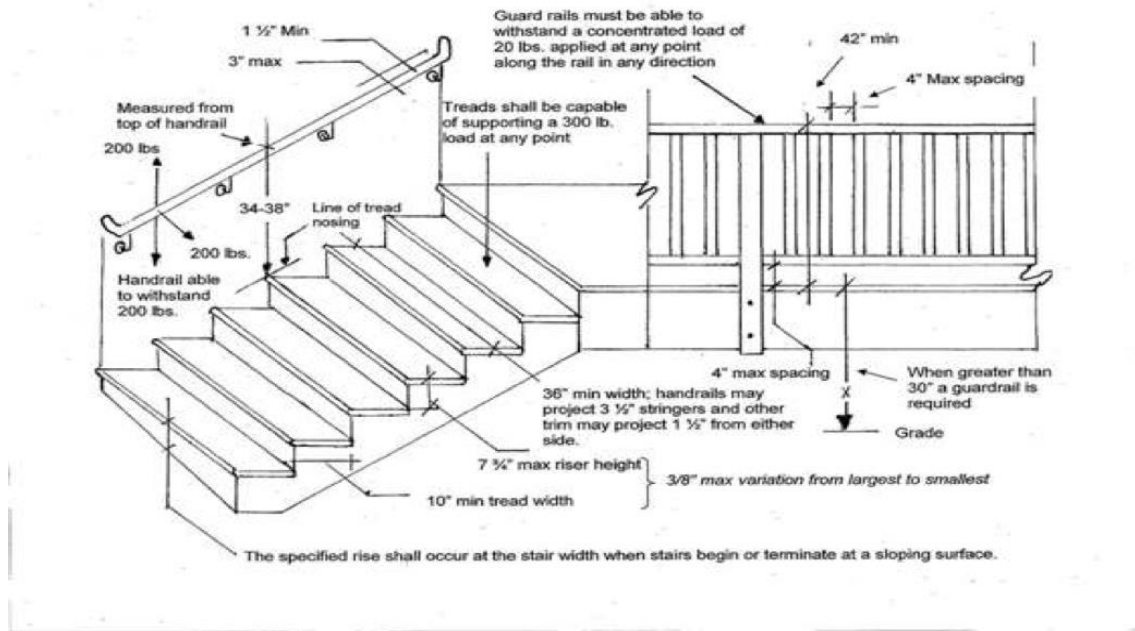

## Stair Layout

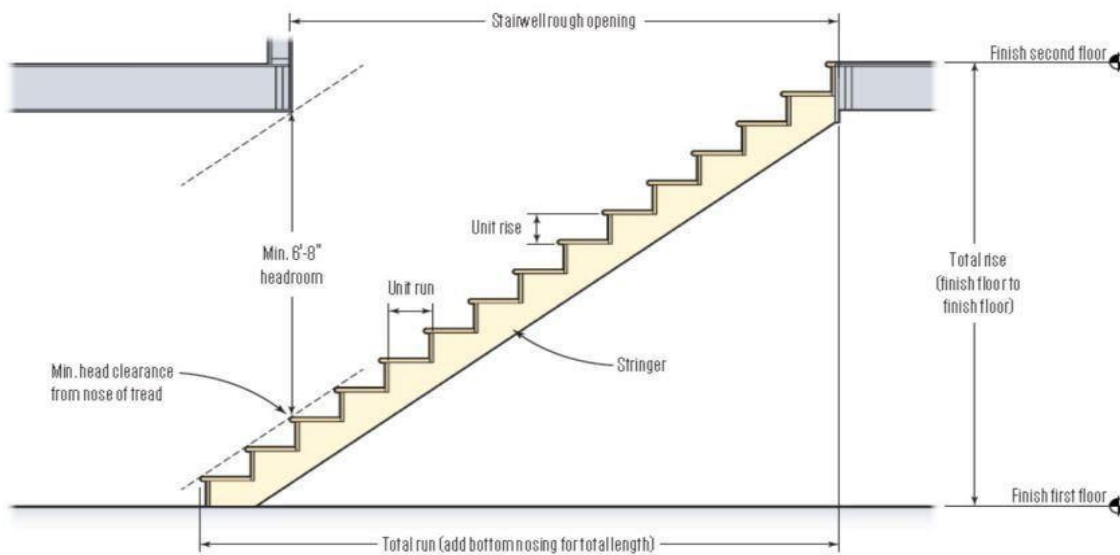

Maximum 12'



# Basic Stairs Guard

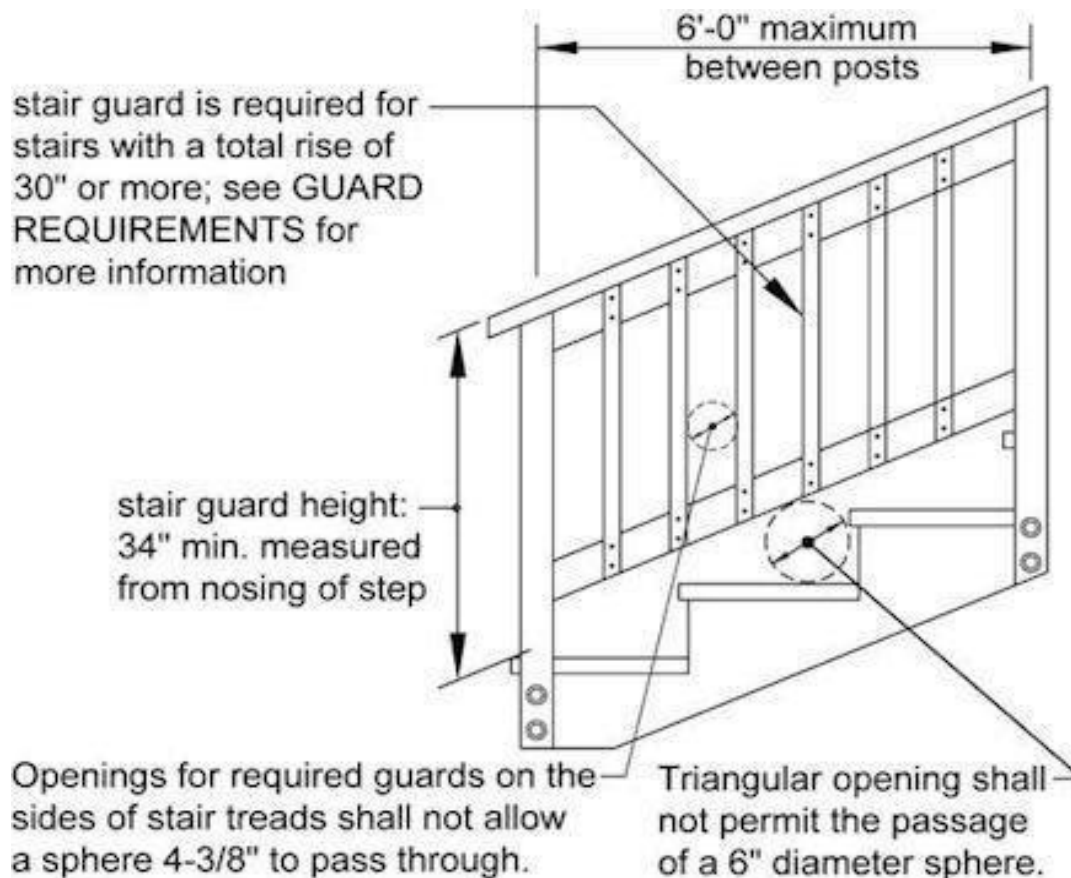

## Guard Elevation R312

### General Information:

1. Consult with the Building Department regarding required setbacks.
2. Obtain a Building Permit before starting construction.
3. The intent of this sheet is to address the basics of private residential stair construction ONLY and does not address the subject in great detail. Additional information is available in your Building Department, home improvement store or library.
4. This Tip Sheet is intended to show code requirements per the 2012 International Residential Code (IRC).

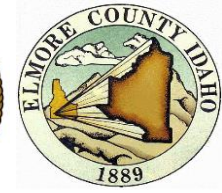

# Basic Stairs - Handrails

## Acceptable Handrail Shapes at Guards

### Handrail Mounting

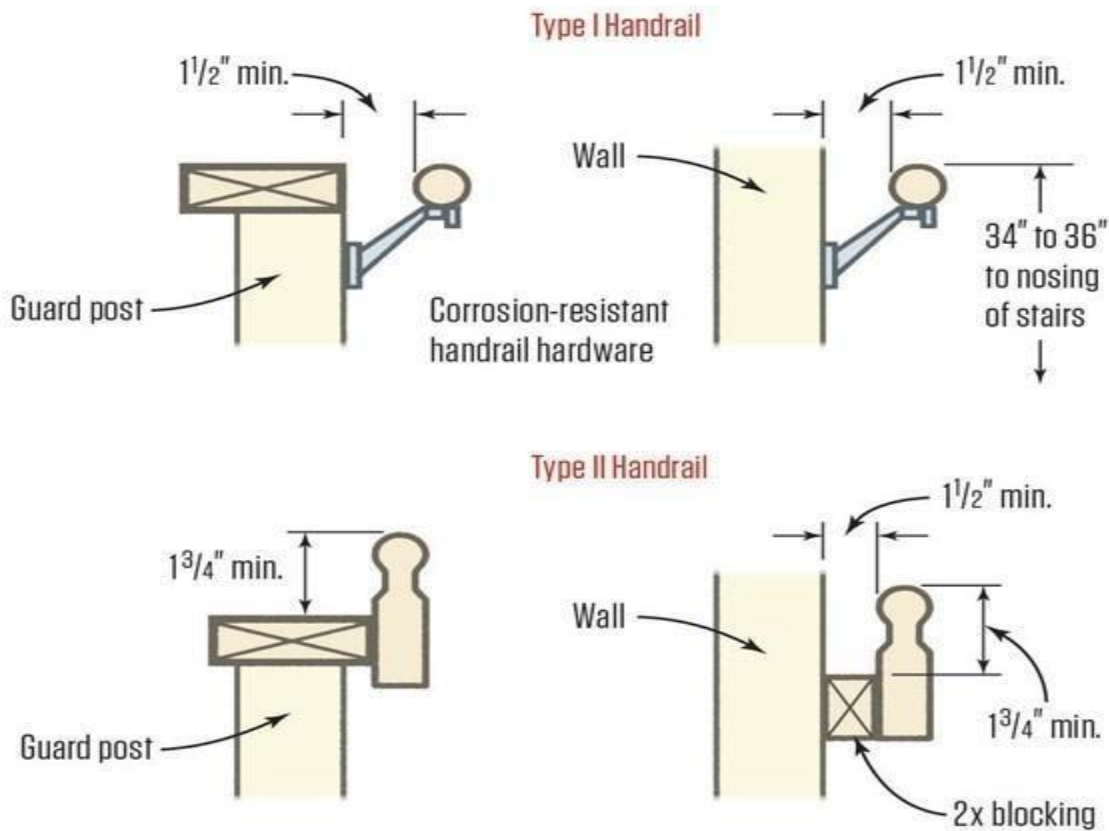

Type I Handrails R311.7.8.3 and Type II Handrails R311.7.8.3 (at handrails with perimeter greater than  $6\frac{1}{4}"$ )



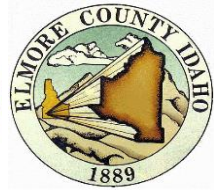

# Smoke Alarms/Detectors

**R314:** Smoke alarms must be audible in all parts of the house and installed per manufacturer's instructions

**New Houses:** Alarms are required and must be connected to the main electrical system with battery backup. Wireless Detectors are allowed (R314).

**Existing Houses (IRC R314.3.1):** Alarms are required for any addition or repair work requiring a building permit, except exterior surface work such as re-roofing. Alarms must be interconnected and hard wired. Exception: Alarms will not be required to be interconnected and hard wired where the permit work does not require the removal of interior wall or ceiling finishes unless there is an attic, crawlspace, or basement available where access is provided.

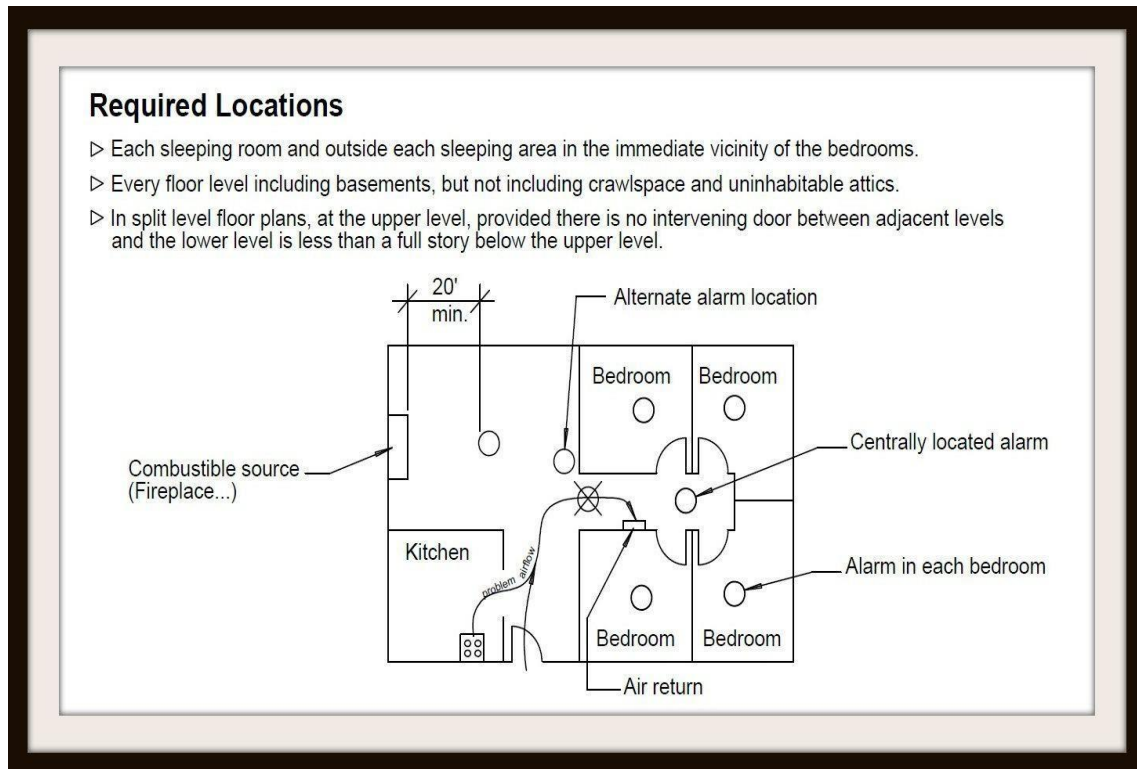



# Smoke Alarms

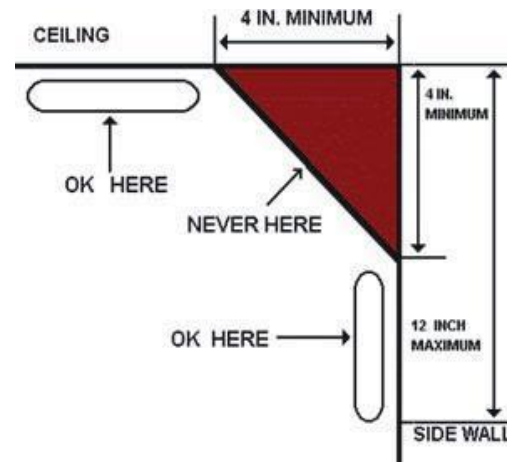
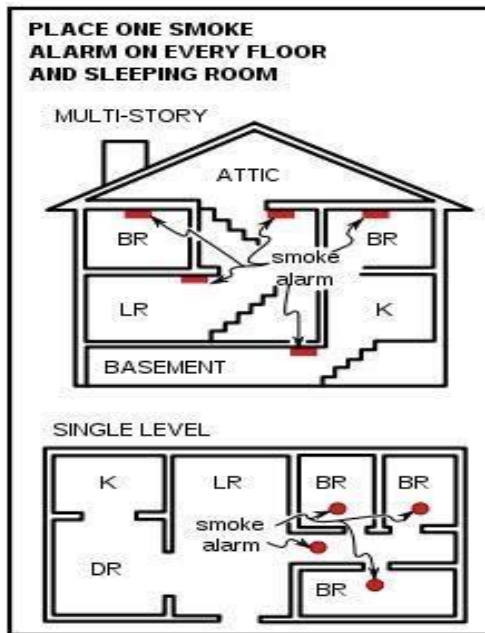

## Avoid these locations for alarms:

- Near combustible sources, fireplaces, furnaces, hot water heaters, space heaters, kitchens, garages with vehicle exhaust. Place alarms at least 20 feet away from such sources.
- In air streams passing by kitchens.
- In damp areas such as bathrooms with showers. Place alarms at least 10 feet away from such sources.
- In very cold or hot areas such as unheated or outdoor rooms where the temperature will fall out of the alarm operating range.
- In very dusty or dirty areas where the vents of the alarm could become clogged.
- Near fresh air vents or drafty areas such as air conditioners, heaters, floor and ceiling fans...
- In dead air spaces.
- In insect-infested areas. Install bug screens
- Near fluorescent lights. Place alarms at least 5 feet away from such sources.



# Basic Decks

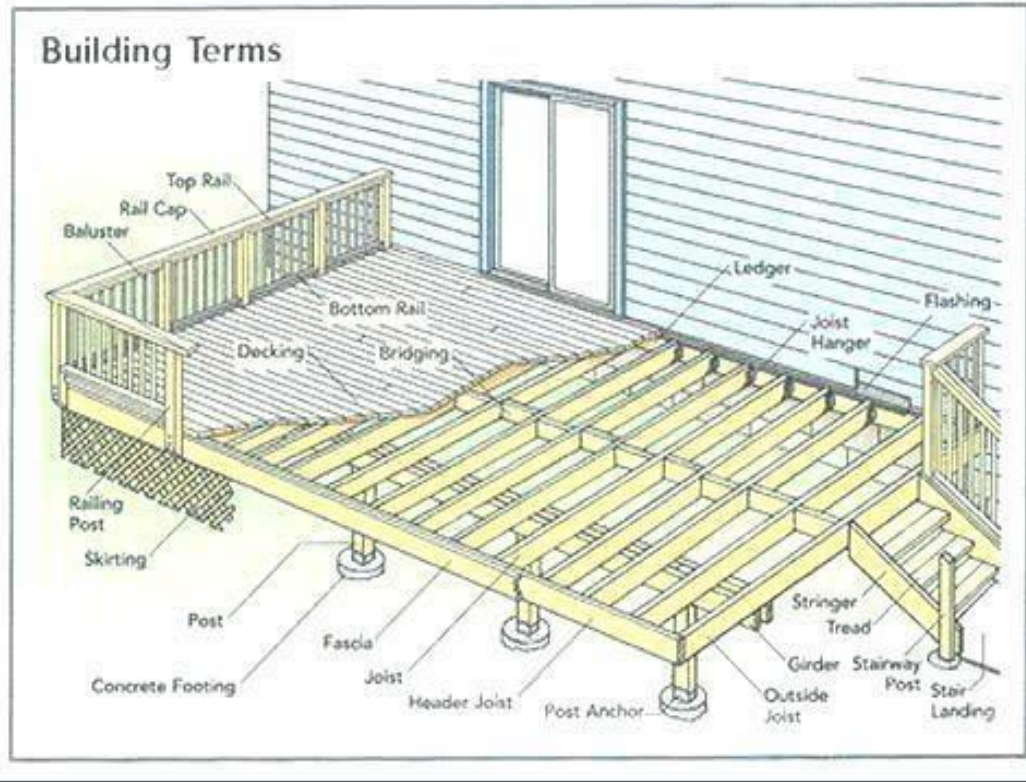

## Deck Construction Notes:

1. Treat all cut ends with end-cut solution. Use ground-contact treated woods.
2. Fasteners, hangers, nails, etc. must be stainless steel, hot-dipped galvanized, or as specifically for the specified wood preservative used. The coating weights for zinc-coated fasteners to be in accordance with ASTM A 153. Provide documentation in the field showing the required fastener protection considering the wood chosen for the deck.
3. You may modify any components of this Tip Sheet with justification by analysis or calculation. Any modifications must be reviewed prior to permit issuance.
4. Design - Decks.com Design Decks.
5. Tools - AWC - DCAG Deck Construction Guide.

## Submittal Requirements:

1. One (1) set of plans showing dimensions of the deck and its relationship to existing buildings or structures on the property and the distance to existing property lines drawn to scale. Include the project address on the drawings.
2. One (1) copy of plan showing the framing layout of the deck.
3. A completed Building permit application with associated fees.

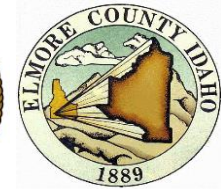

# Basic Deck (cont'd)

Table 3. Deck Beam Spans ( $L_B$ )<sup>1</sup>

Species	Size	Joist Spans ( $L_J$ ) Less Than or Equal to:						
		6'	8'	10'	12'	14'	16'	18'
Southern Pine	2-2x6	7' - 1"	6' - 2"	5' - 6"	5' - 0"	4' - 8"	4' - 4"	4' - 1"
	2-2x8	9' - 2"	7' - 11"	7' - 1"	6' - 6"	6' - 0"	5' - 7"	5' - 3"
	2-2x10	11' - 10"	10' - 3"	9' - 2"	8' - 5"	7' - 9"	7' - 3"	6' - 10"
	2-2x12	13' - 11"	12' - 0"	10' - 9"	9' - 10"	9' - 1"	8' - 6"	8' - 0"
	3-2x6	8' - 7"	7' - 8"	6' - 11"	6' - 3"	5' - 10"	5' - 5"	5' - 2"
	3-2x8	11' - 4"	9' - 11"	8' - 11"	8' - 1"	7' - 6"	7' - 0"	6' - 7"
	3-2x10	14' - 5"	12' - 10"	11' - 6"	10' - 6"	9' - 9"	9' - 1"	8' - 7"
	3-2x12	17' - 5"	15' - 1"	13' - 6"	12' - 4"	11' - 5"	10' - 8"	10' - 1"
Douglas Fir- Larch <sup>2</sup> , Hem-Fir <sup>2</sup> , SPF <sup>2</sup> , Redwood, Western Cedars, Ponderosa Pine <sup>3</sup> , Red Pine <sup>3</sup>	3x6 or 2-2x6	5' - 5"	4' - 8"	4' - 2"	3' - 10"	3' - 6"	3' - 1"	2' - 9"
	3x8 or 2-2x8	6' - 10"	5' - 11"	5' - 4"	4' - 10"	4' - 6"	4' - 1"	3' - 8"
	3x10 or 2-2x10	8' - 4"	7' - 3"	6' - 6"	5' - 11"	5' - 6"	5' - 1"	4' - 8"
	3x12 or 2-2x12	9' - 8"	8' - 5"	7' - 6"	6' - 10"	6' - 4"	5' - 11"	5' - 7"
	4x6	6' - 5"	5' - 6"	4' - 11"	4' - 6"	4' - 2"	3' - 11"	3' - 8"
	4x8	8' - 5"	7' - 3"	6' - 6"	5' - 11"	5' - 6"	5' - 2"	4' - 10"
	4x10	9' - 11"	8' - 7"	7' - 8"	7' - 0"	6' - 6"	6' - 1"	5' - 8"
	4x12	11' - 5"	9' - 11"	8' - 10"	8' - 1"	7' - 6"	7' - 0"	6' - 7"
3-2x6	7' - 4"	6' - 8"	6' - 0"	5' - 6"	5' - 1"	4' - 9"	4' - 6"	
3-2x8	9' - 8"	8' - 6"	7' - 7"	6' - 11"	6' - 5"	6' - 0"	5' - 8"	
3-2x10	12' - 0"	10' - 5"	9' - 4"	8' - 6"	7' - 10"	7' - 4"	6' - 11"	
3-2x12	13' - 11"	12' - 1"	10' - 9"	9' - 10"	9' - 1"	8' - 6"	8' - 1"	

1. Assumes 40 psf live load, 10 psf dead load, L/360 simple span beam deflection limit, L/180 cantilever deflection limit, No. 2 grade, and wet service conditions.
2. Incising assumed for refractory species including Douglas fir-larch, hem-fir, and spruce-pine-fir.
3. Design values based on northern species with no incising assumed.



## Basic Deck (cont'd)

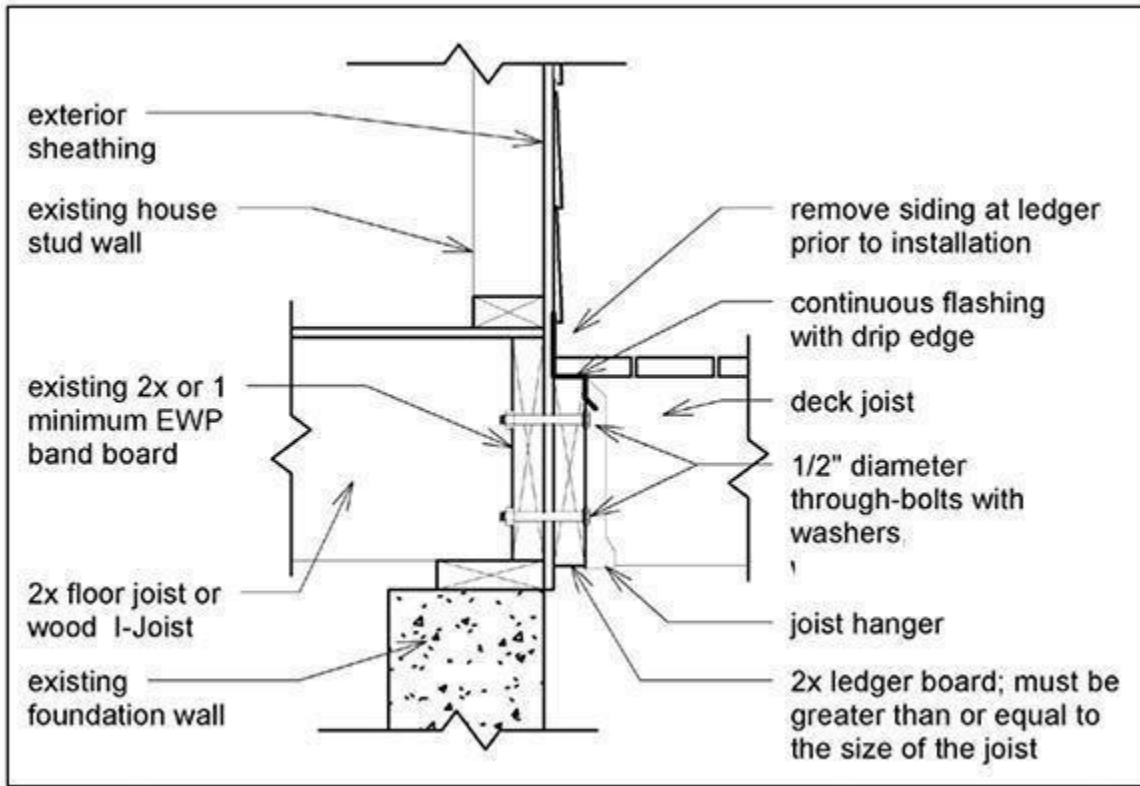
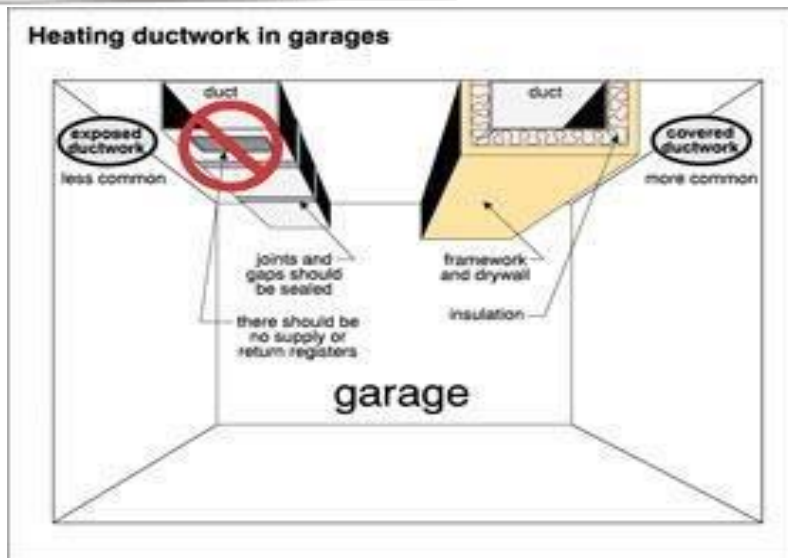
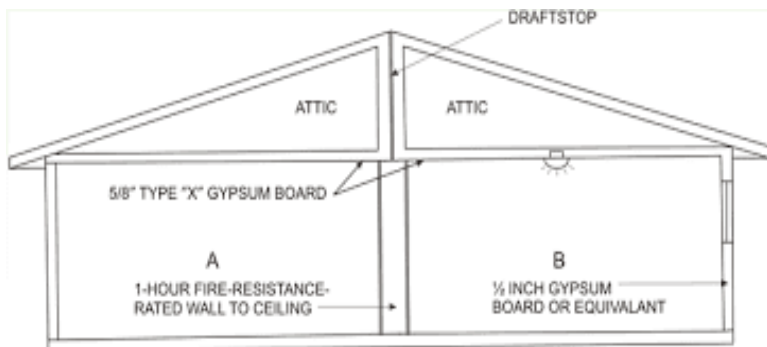

**FIGURE 14: ATTACHMENT OF LEDGER BOARD-TO-BAND BOARD**



# Garage Separation

IRC R302.6: Garages beneath habitable rooms must be separated at the ceiling with 5/8" type X gypsum board. The structure supporting the separation and walls between the residence and garage must be protected by not less than 1/2" gypsum board.



Ducts: in the garage and ducts penetrating the walls and ceilings separating the dwelling walls or ceilings separating the dwelling from the garage must be of 26-gauge sheet metal with no register outlets into the garage.

Ducts outside the protected envelope are excluded from these regulations.

Doors: doors separating the garage and living room spaces are 1 3/8" solid wood, solid or honeycomb core steel doors not less than 1 3/8" or 20-minute fire-rated door.

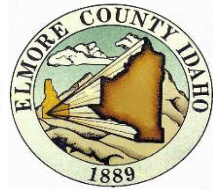

# Residential Emergency Escape and Rescue Openings

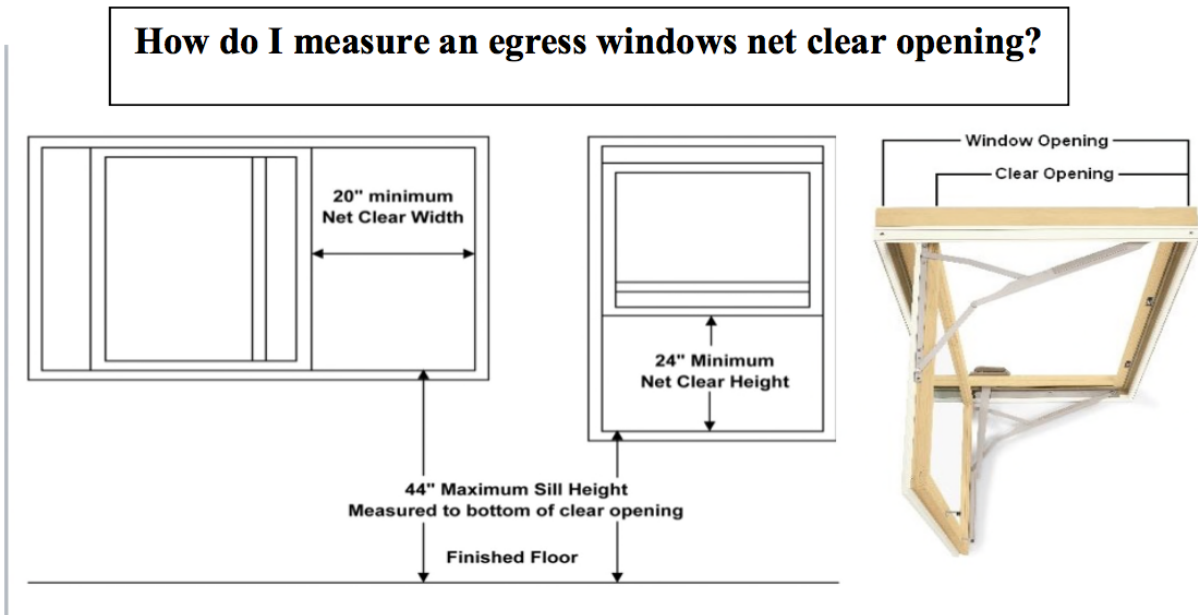

IRC R310: Basements and every sleeping room need at least one openable emergency escape or rescue opening.

The minimum net clear opening of 5.7 s.f. is required. Exceptions: grade floor openings may have a net clear opening of 5 s.f.

## General Information:

1. The intent of this sheet is to address the basics of residential emergency escape and rescue openings **ONLY** and does not address the subject in great detail. Additional information can be found at your local building department, home improvement store, or library.



# Residential Emergency Escape and Rescue Openings (cont'd)

## R312 Guards and Window Fall Protection

**R312.2.1 Windowsills.** In dwelling units, where the opening of an operable window is located more than 72 inches (1829mm) above the finished grade or surface below, the lowest part of the clear opening of the window shall be a minimum of 24 inches (610 mm) above the finished floor of the room in which the window is located. Operable sections of windows shall not permit openings that allow passage of a 4-inch (102 mm) diameter sphere where such openings are located within 24-inches (610 mm) of the finished floor.

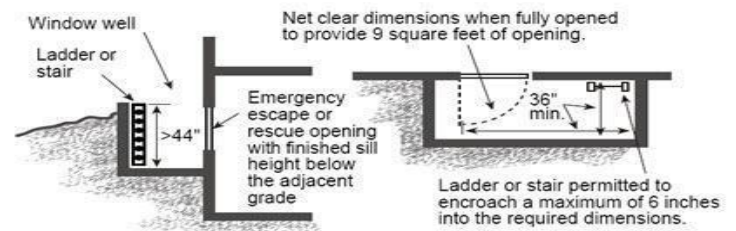
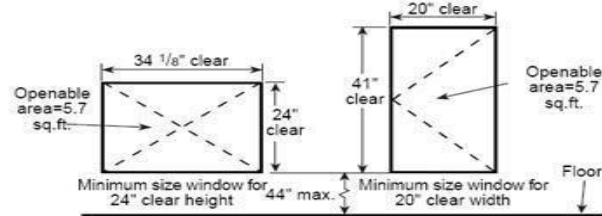
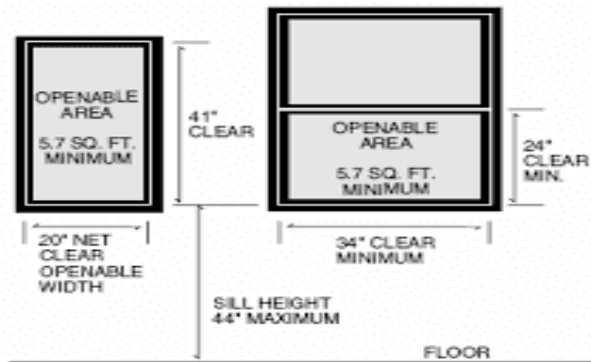

### Exceptions:

1. Windows whose openings will not allow 4-inch diameter (102 mm) sphere to pass through the opening when the opening is in its largest opened position.





# Notching and Boring Rafters/Joist/Studs

IRC R502.8 & R802.7

$D/3$  = 1/3 the depth of the joist

$D/4$  = 1/4 the depth of the joist

$D/6$  = 1/6 the depth of the joist

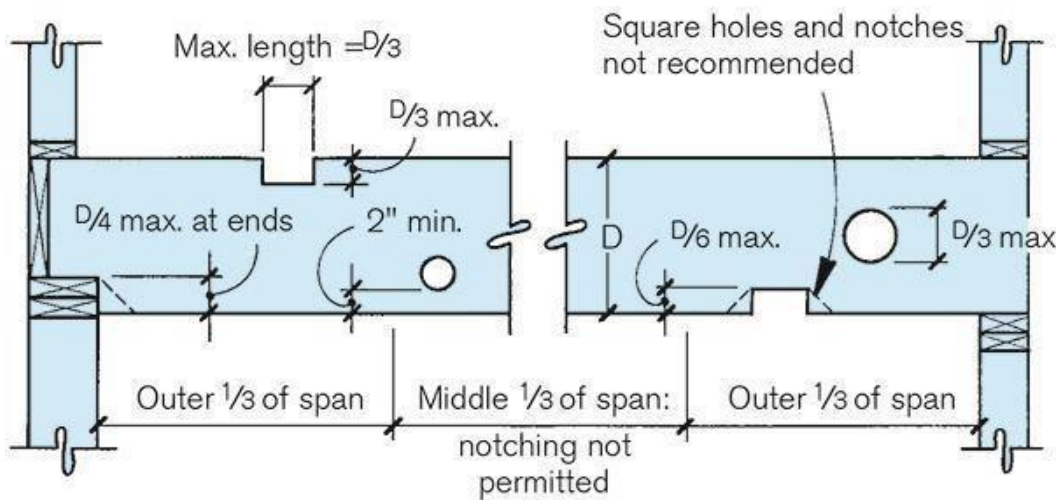

NOTE: A notch not exceeding 1/3 the depth of the member is permitted in the top of a rafter or ceiling joist not further from the face of the support than the depth of the member.

The tension side of members 4" or greater in thickness must not be notched except at the ends of the member.

### General Information:

1. The intent of this tip is to address the restrictions of the Notching and Boring of studs in one, two and three-story residential structures. For specific questions not addressed her or requiring further clarification, please contact the Building Department.
2. This tip does not supersede information shown on approved plans prepared by a licensed architect or engineer.

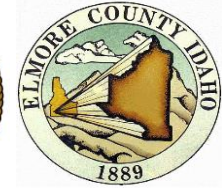

# Notching and Boring Rafters/Joist/Studs (cont'd)

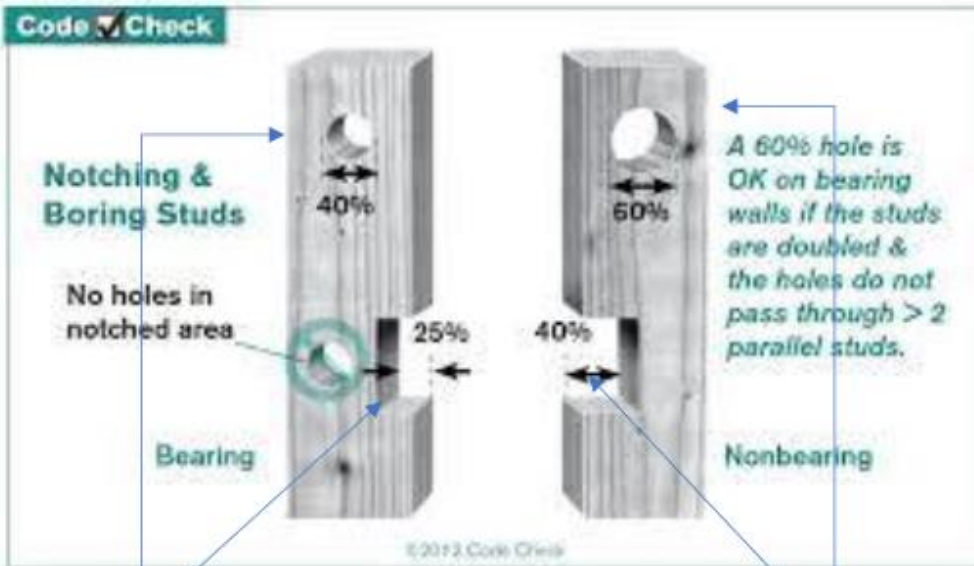

In exterior walls and bearing walls, any wood stud may be cut or notched to a depth not exceeding 25% of its width.

In non-bearing partitions supporting no loads other than the weight of the partition, cutting or notching is allowed to a depth not greater than 40% of the width of the stud.

A hole not greater than 40% of the width may be bored into any stud; and no hole is located in the same section as a cut or notch.

Holes up to 60% of the width may be bored in non-bearing partitions or in any wall where each bored stud is doubled, provided not more than two such successive studs are bored.

In no case may the edge of the bored hole be nearer than 5/8" to the edge of the stud.

Bored holes may not be located in the same section of stud as a cut or notch.



# Notching and Boring Rafters/Joist/Studs (cont'd)

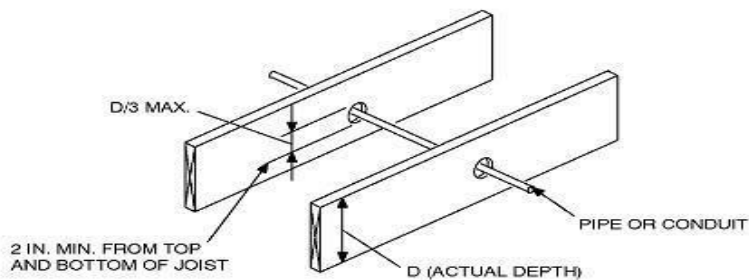
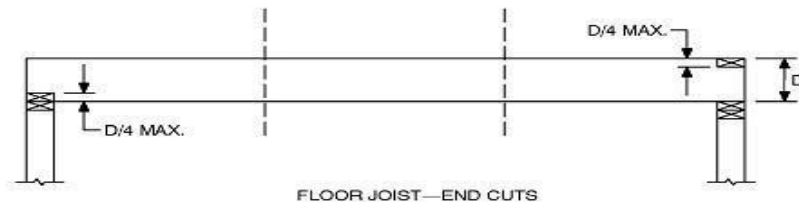
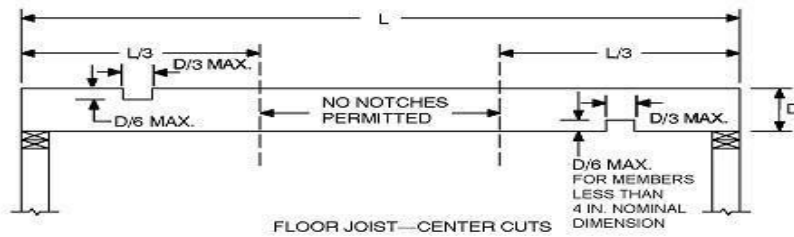
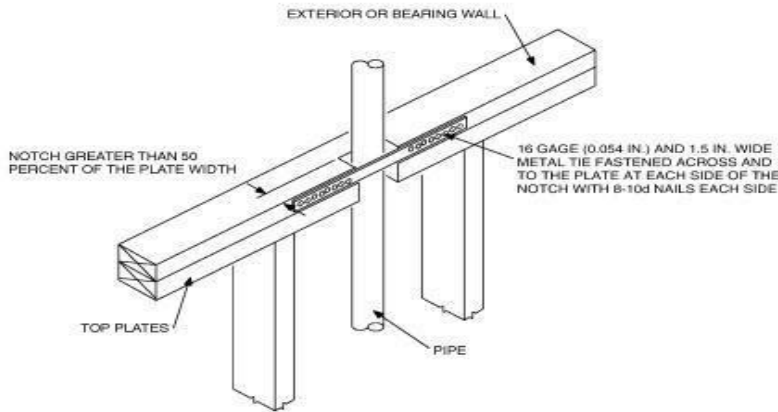



# Fire Protection of Horizontal Venting

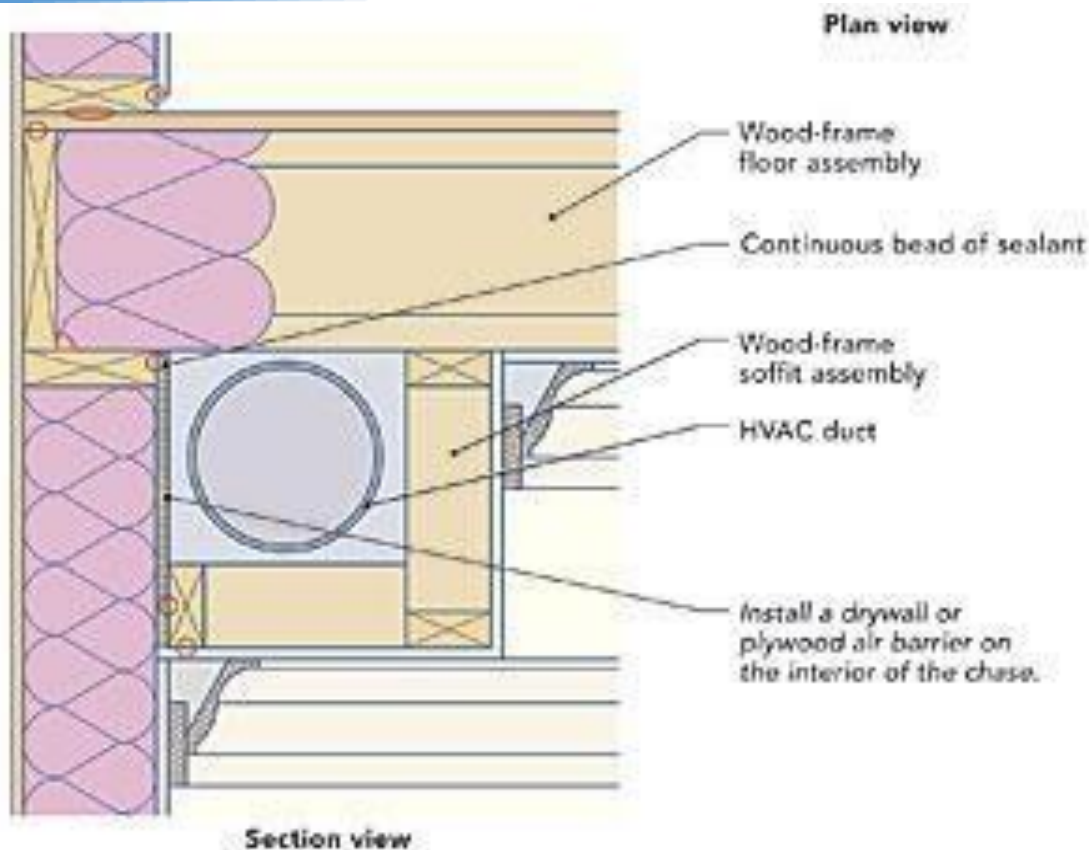

## General Information:

1. The intent of this tip is to address the requirements of horizontal venting **ONLY** in residential structures. For specific questions not addressed here or requiring further clarification, please contact the Building Department.
2. Intended for heat, vent, cooling and exhaust ducts only.



# Safety Glazing

## Safety Glass Identification Required

Each pane of glazing installed in hazardous locations must be provided with a manufacturer's or installer's label, designing the type and thickness of glass and the safety glazing with which it complies. The label needs to be visible at the final inspection, and it must be acid-etched, sandblasted, ceramic-fired, or an embossed mark or the type which once applied cannot be removed without being destroyed.

## Safety glazing Required Locations:

1. Glazing in swinging doors except louvered windows and jalousies complying with IRC R308.2.
2. Glazing in fixed and sliding panels of sliding door assemblies and panels in sliding and bi-fold closet door assemblies.
3. Glazing in storm doors.
4. Glazing in all unframed swinging doors.
5. Glazing in doors and enclosures for hot tubs, whirlpools, saunas, steam rooms, bathrooms and showers. Glazing in any portion of a building wall enclosing these compartments where the bottom exposed edge of the glazing is less than 60" above any standing or walking surface.
  - Exception: Openings through which a 3" sphere is unable to pass.
6. Glazing in fixed or operable panels adjacent to a door where the nearest vertical is within a 24" arc of the door in a closed position and where the bottom exposed edge of the glazing is less than 60" above the walking surface.
  - Exception: Where there is an intervening wall or partition between door and glazing or where the door accesses a close 3' or less in depth.
7. Glazing in an individual fixed or operable panel, when all of the following apply:
  - 7.1 Exposed area of an individual pane greater than 9 s.f.
  - 7.2 Bottom edge less than 18" above the floor.
  - 7.3 Top edge greater than 36" above the floor.
  - 7.4 One or more walking surfaces within 36" horizontally of the glazing.
    - Exception: Where a protective 1 ½" wide bar is installed on the accessible side of the glazing 34" - 38" above the floor and is capable of withstanding a load of 50 lbs. per lineal foot, or where the bottom edge of the glass is 25' or more above grade, walking surface or other horizontal surface.
8. Glazing in railings regardless of area or height above a walking surface. Includes structural baluster panels and nonstructural fill panels.
9. Glazing in walls and fences enclosing indoor and outdoor swimming pools, hot tubs and spas where the bottom edge of the glazing is less than 60" above a walking surface and within 60" horizontally of the water's edge. This will apply to all single glazing and all panes in multiple glazing.
10. Glazing adjacent to stairways, landings and ramps with 36" horizontally of a walking surface with the exposed surface of the glass is less than 60" above the plane of the adjacent walking surface.
  - Exception: Where a handrail or guard is installed per IBC 1003.3.12 & 1607.7 or when the glass is greater than 18" from the railing.
11. Glazing adjacent to stairways with 60" horizontally of the bottom tread of stairway in any direction when the exposed surface of the glass is less than 60" above the nose of the tread.
  - Exception Where a handrail or guard is installed per the IBC 1003.3.12 & 1607.7 or when the glass is greater than 18" from the railing.



# Safety Glazing (cont'd)

Glazing in doors, Enclosures for Hot Tubs, Whirlpool, Saunas, Steam Rooms, Bathtubs and Showers:

Safety glazing is required at glazing in a building wall enclosing these wet areas where the bottom edge of the glazing is less than 60" above a standing surface and drain inlet.

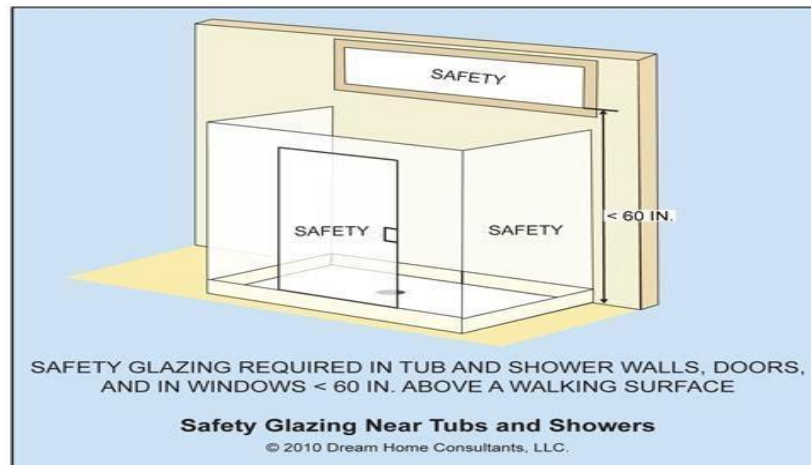

Glazing at a Swimming Pool or Spa:

Safety glazing is required when the bottom edge of the glazing in walls and fences used the barrier for indoor and outdoor swimming pools and spas is less than 60" above the pool side of the barrier for indoor and outdoor swimming pools and spas is less than 60" above the pool side of the glazing and the glazing is within 60" of a swimming pool or spa water's edge.

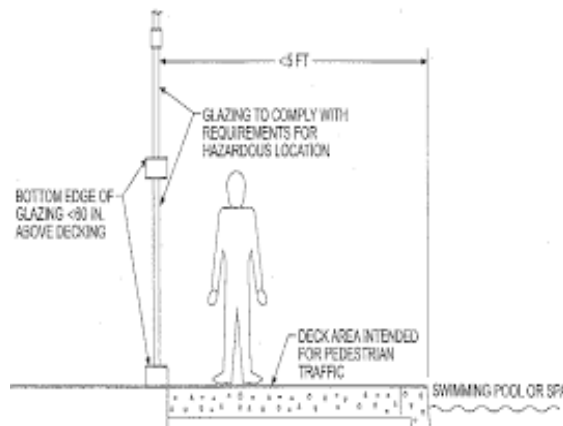

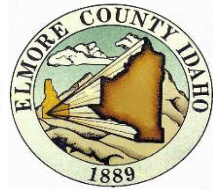

# Safety Glazing (cont'd)

## Glazing Adjacent to Doors:

Safety glazing is required for all glazing within a 24" arc of either vertical edge of a door.

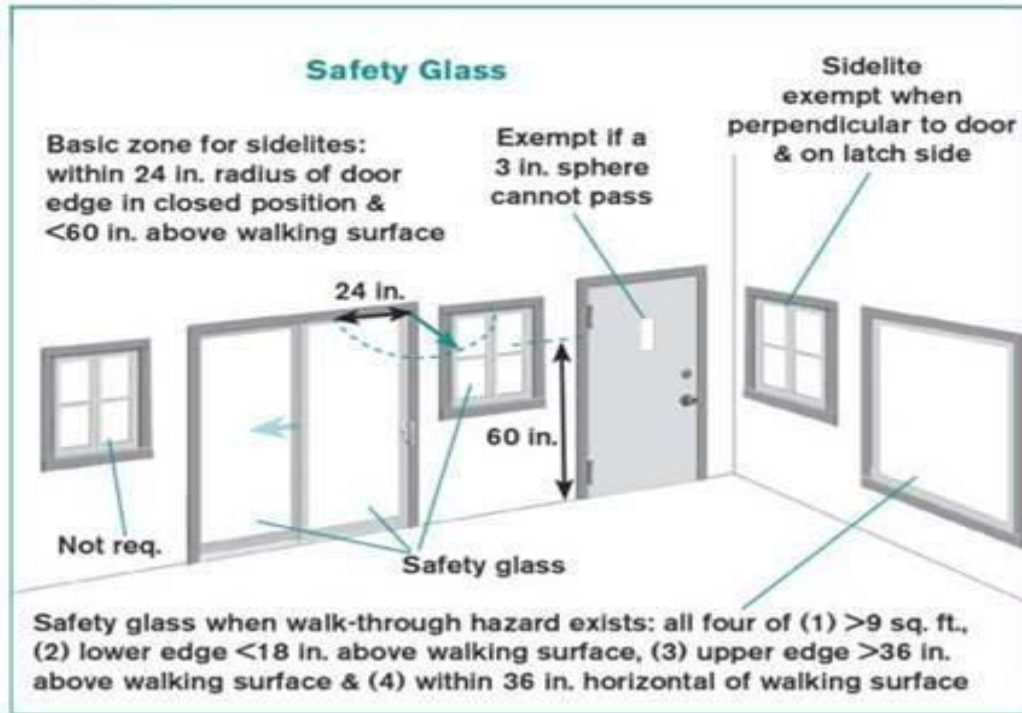

Also, not required when:

1. The exposed bottom edge of glass is 60" or greater above the walking surface.
2. There is an intervening wall or other permanent barrier between the door and the glazing.
3. Access through the door is to a closet or storage area 3' or less in depth.

Safety glass is not required for panel with exposed edges 60" or greater above the walking surface or when panel is outside 24" arc of door edge.

Safety glazing is required for all panels with exposed edges less than 60" above walking surface and within 24" of door.



# Safety Glazing (cont'd)

Safety glazing required at fixed or operable panels at interior and exterior glass except as noted below:

- A. Walking surface is away horizontally 36" or more from the plane of the glazing.
- B. Exposed bottom edge is 18" or greater above the floor.
- C. Exposed top edge is 36" or less above the floor.
- D. Exposed area of an individual pane is 9 s.f. or less.
- E. When a protective bar is installed.

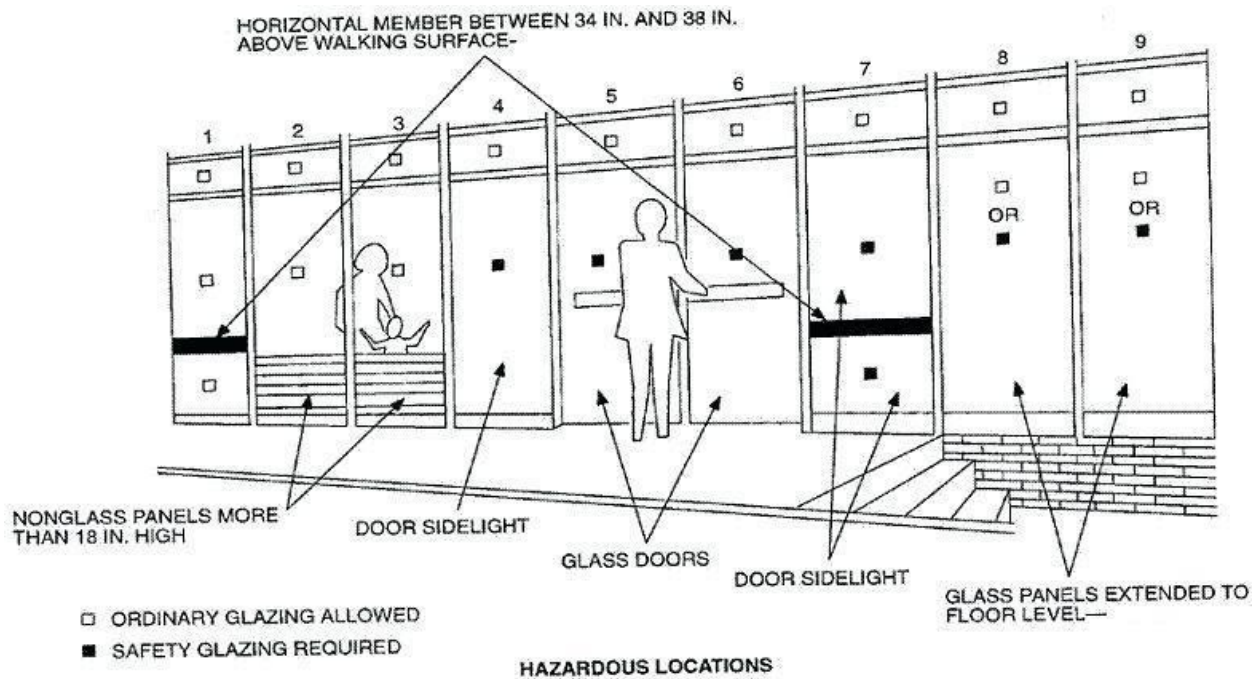

Note:

Protective Bar must be capable of withstanding a horizontal load of 50 lbs. per lineal foot without contacting the glass, on accessible sides, on 34" to 38" above the floor, and minimum 1-1/2" in height.





# Safety Glazing (cont'd)

## R308.4.6 Glazing Adjacent Stairs and Ramps

For glazing that is not considered to be in a hazardous location, the rule for the minimum height above a tread at the side of a stairway is now 36 inches to correspond to the height of a guard as previously found in the exception. Other revisions to the text clarify the meaning and application of the glazing requirements at stairway.

## R308.4.6 Glazing Adjacent to Stairs and Ramps

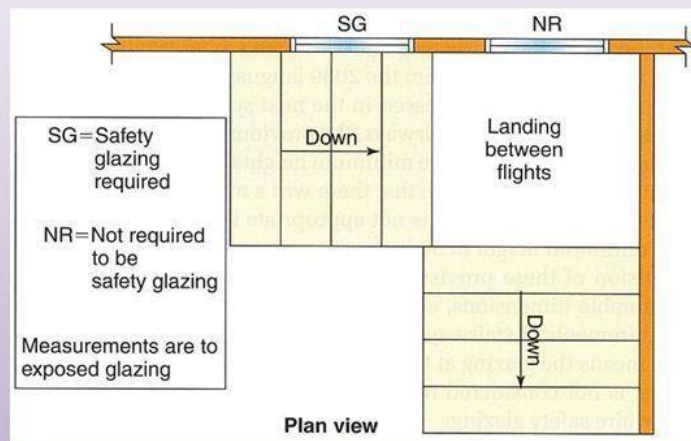
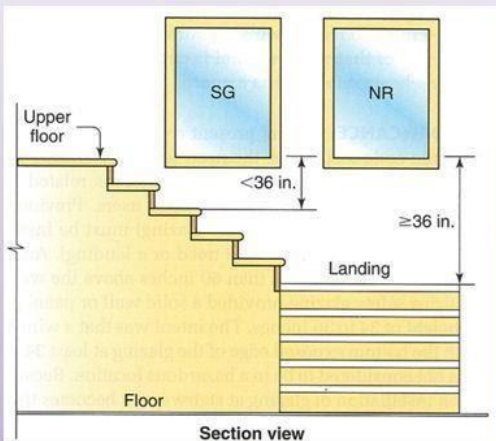



# Safety Glazing (cont'd)

## R312 Guards and Window Fall Protection

CHANGE TYPE: Modification

CHANGE SUMMARY: The provisions for window fall protection have been relocated from Chapter 6 to Chapter 3. The terminology for window opening control devices has been updated for consistency with the referenced standard ASTM F 290. Operation criteria found in the 2008 edition of the standard have been deleted from the prescriptive provisions of the IRC.

2012 CODE:

### SECTION R312

#### GUARDS AND WINDOW FALL PROTECTION

R312.1 Guards. Guards shall be provided in accordance with Sections R312.1.1 through R312.1.4.

R312.1.1 Where Required. [No Change to text]

R312.1.2 Height. [No change to text]

R312.1.3 Opening Limitations. [No change to text]

R312.1.4 Exterior Wood/Plastic Composite Guards. [No change to text]

R312.2 Window Fall Protection. Window fall protection shall be provided in accordance with Sections R312.2.1 and R312.2.2.

R312.2.1 Window Sills. In dwelling units, where the opening of an operable window is located more than 72 inches (1829 mm) above the finished grade of surface below, the lowest part of the clear opening of the window shall be a minimum of 24 inches (610 mm) above the finished floor of the room in which the window is located. Operable (the code continues)

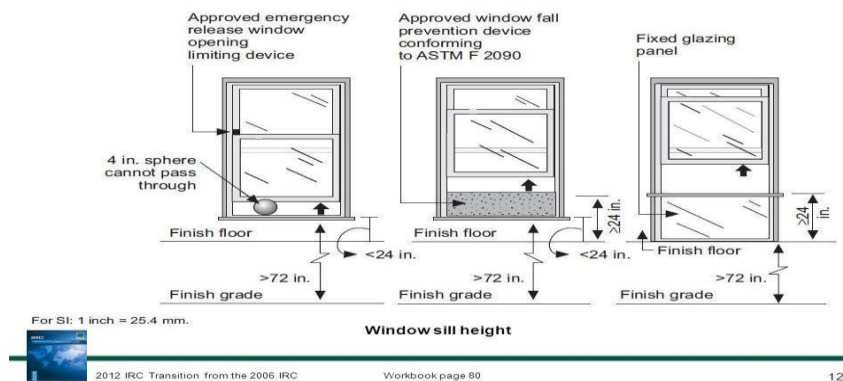



# Typical Wall Framing

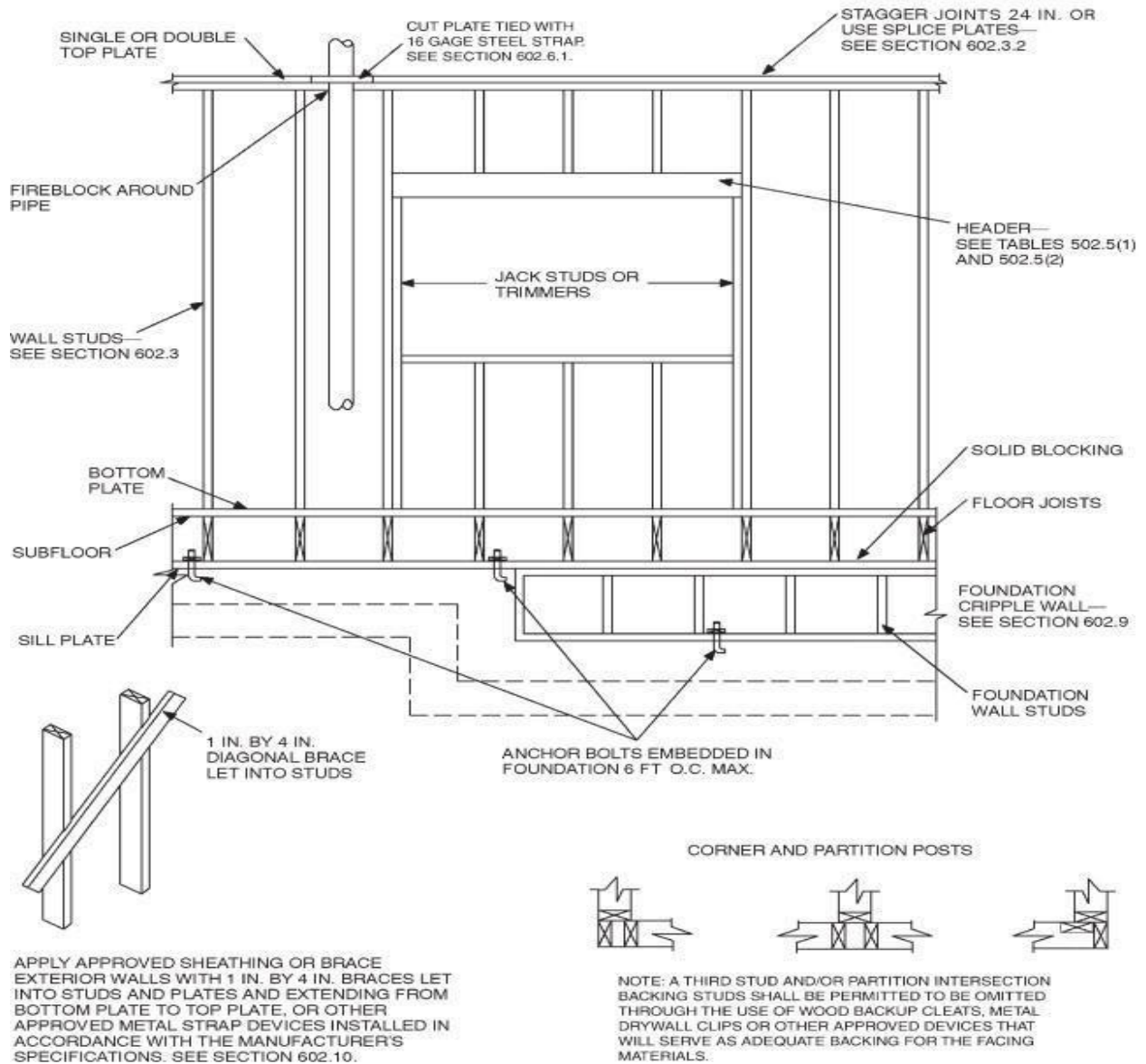



# Typical Wall Framing (cont'd)

## Typical Two-Story Wall Framing

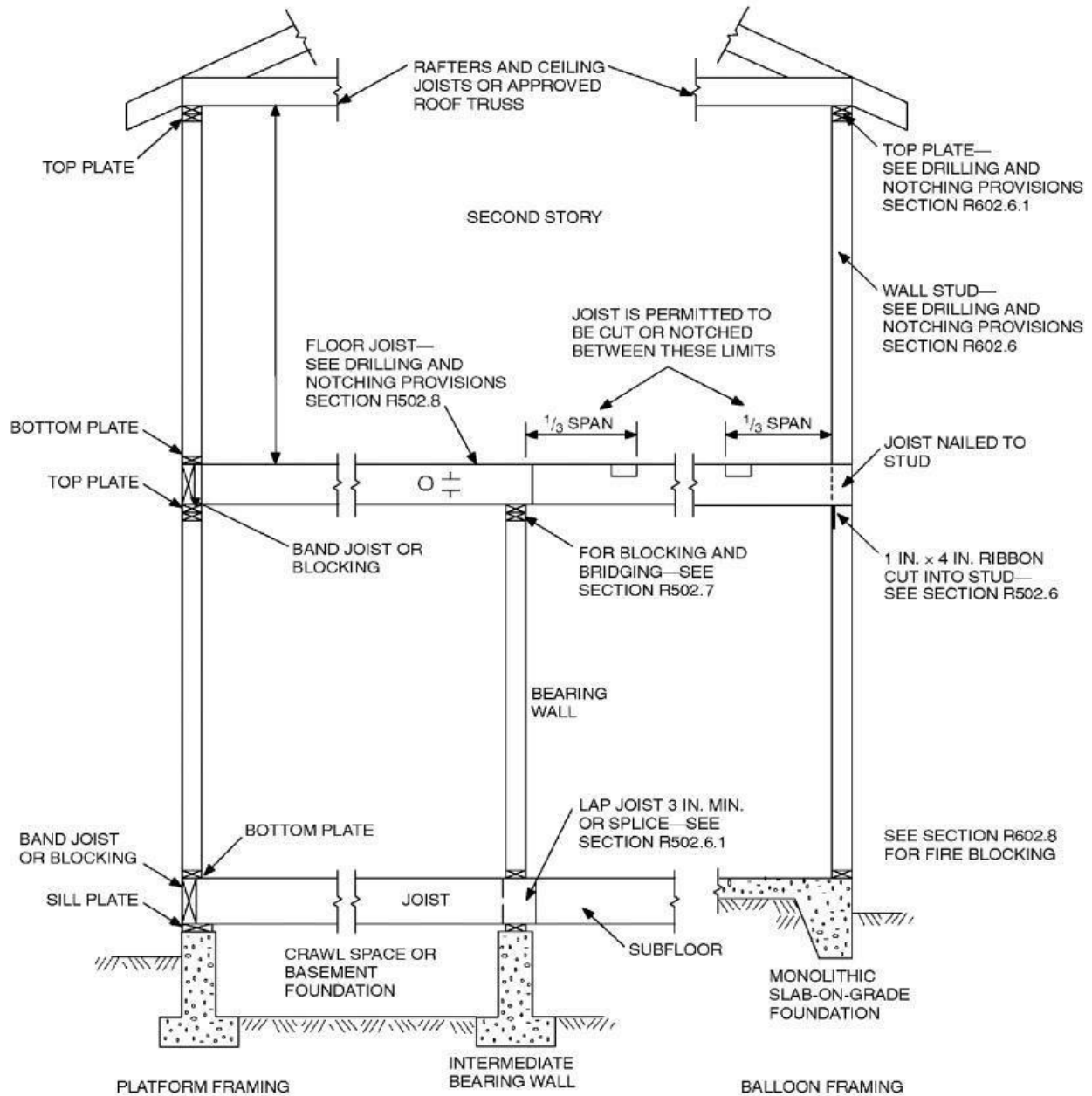

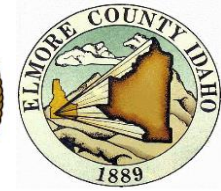

# Site Plan Example

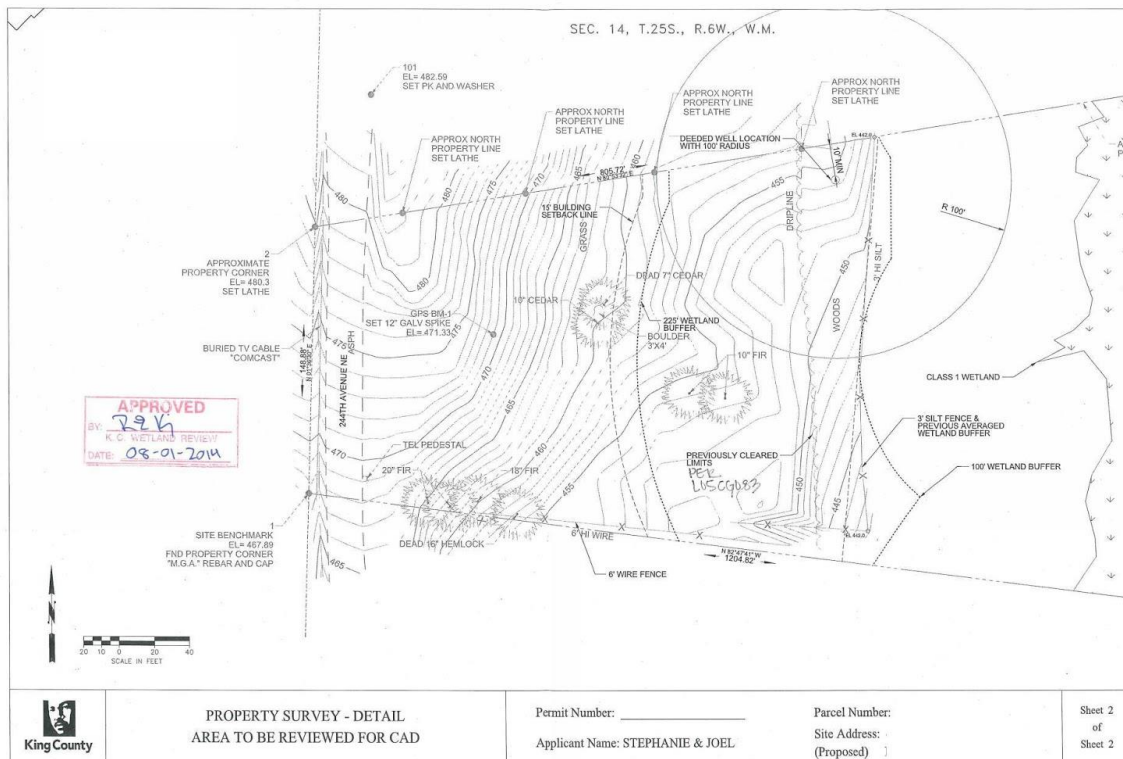

## Inspection Requirements:

- There is a 180-day period in which to begin construction.
- A start constitutes a poured foundation or equal
- It is the applicant's responsibility to make sure the permit does not expire.
- Failure to commence the project or abandonment of construction for 180-days results in expiration of the permit.
- Continued construction activity must be verified through regular inspections.
- Post your INSPECTION RECORD in a conspicuous place when construction begins and leave it posted until all inspections have been satisfied.
- That inspection record is your proof that the required inspections have been completed and it should be retained along with all other important paperwork concerning the project.
- Post the job address at the road so that the site can be found easily by the inspectors.



# Site Plan Example (cont'd)

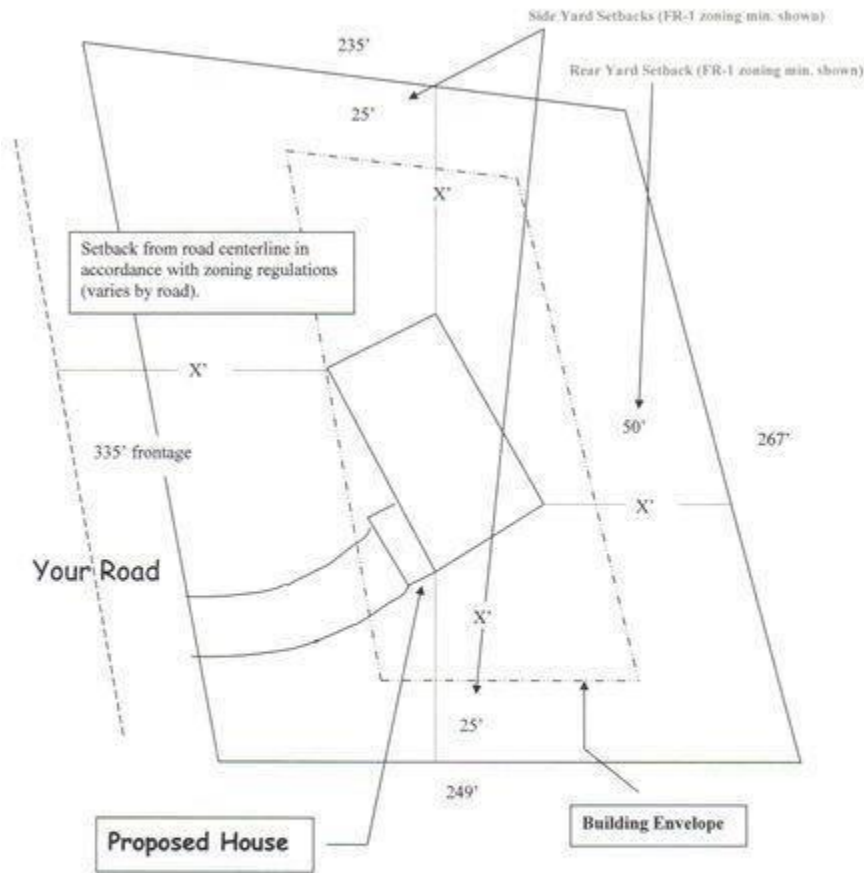

Landowner  
12345 Country Road  
Delaware, Ohio 43015





# Footings

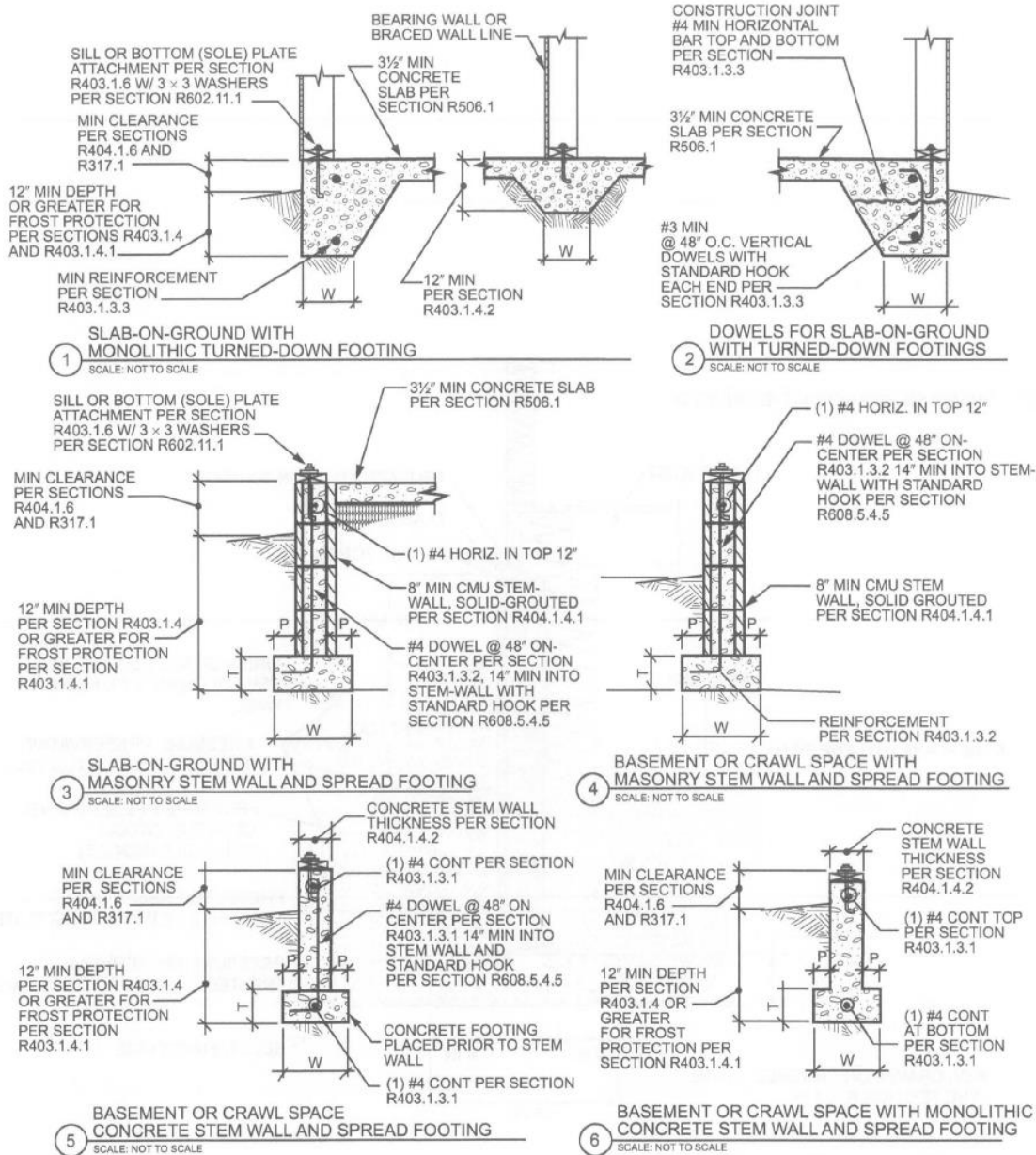

Note:

1. Foundations in seismic A, B, C do not require reinforcement.



# Sample Plan

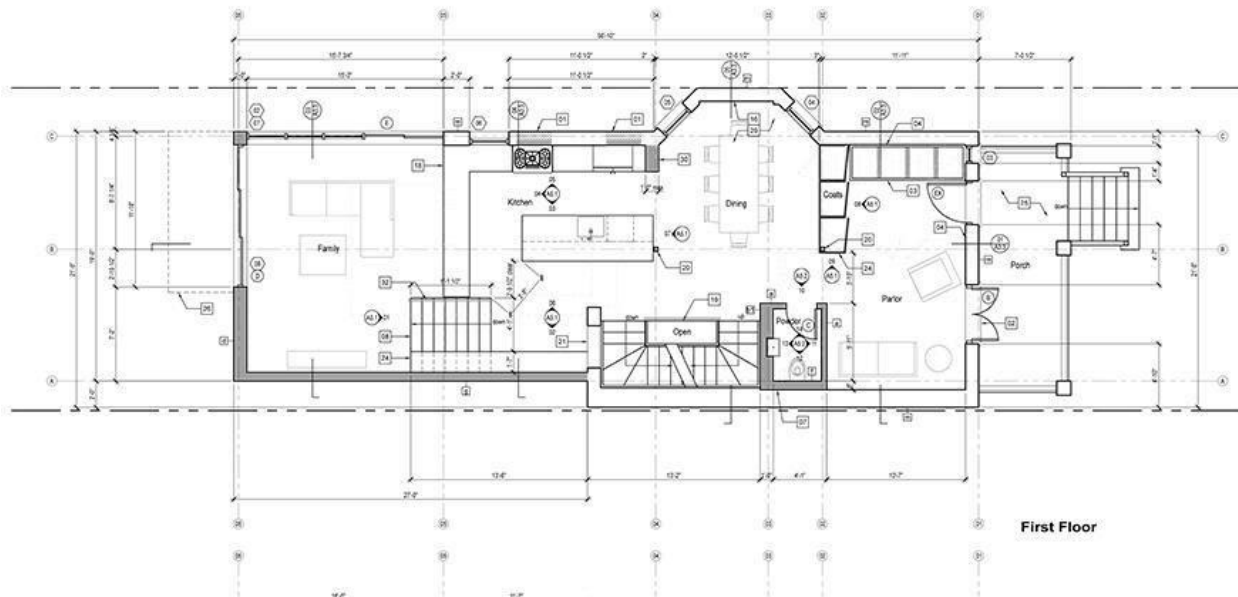

## Notes:

1. Slab at garage floor shall be 4" thick over compacted fill.
2. Foundation plates shall be bolted to foundation with not less than  $\frac{1}{2}$ " steel bolts embedded 7" minimum into concrete spaced not more than 12" apart with at least 2 bolts per piece. Washers are required.
3. See framing plan for steel requirements.
4. Foundation ventilation shall be 1/150 of under floor area shall be vented by approved mechanical means or by openings in exterior perimeter wall. Opening shall be located as close to corners as practical and arranged to provide cross ventilation on at least 2 sides. They shall be covered with corrosion-resistant wire mesh  $\frac{1}{4}$ " openings.
5. Crawl space under floor shall be at least 18" and a minimum of 12" under bottom of girders.
6. Under floor area shall be provided with a minimum of 18" x 24" access hole.
7. Provide 6ml black vapor barrier lapped a minimum of 6" at each joint and extend up to the foundation wall.
8. Dryer to be vented separately to outside.
9. Anchored veneer shall be supported on footing. It shall have an air space between veneer and sheathing. Anchor ties to be corrosion-resistant; 1 for each 2 sq. ft. Add weep holes and flashing.





## Sample Plan (cont'd)

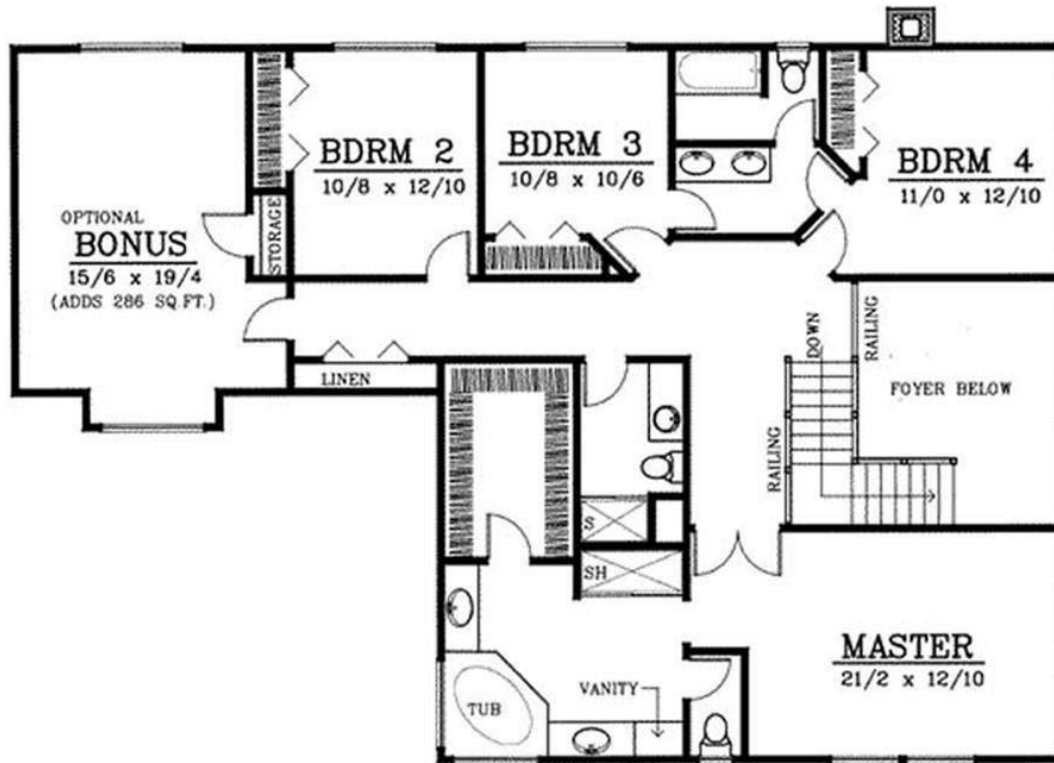

### Notes:

1. Solid Fuel Stoves shall be installed in accordance with manufacturer's instructions.
2. Dryer to be separately vented outside.
3. Attic access to be readily accessible. Minimum size 22" x 30" with 30" unobstructed headroom.
4. Appliance installed in garage shall be located out of the normal path of vehicles or a means of protection shall be provided. Units generating a spark of flame shall have pilots and burners 18" above the floor.
5. If the lid of the garage is used as a fire separation, layers of 5/8" type X G W B shall be applied to framing.
6. Handrails shall be provided on two side opening and continuous on one side only. Handrail shall be 34" above nosing tread and shall be continuous the full length of the stairs and the ends shall return to the wall or shall terminate in a Newell post.
7. Maximum rise  $7 \frac{3}{4}$ " minimum run 10" minimum width 36" minimum headroom 6'8".
8. Handrail to be minimum 34" to 38" in height with balusters not over 4" apart.



# Sample Plan (cont'd)

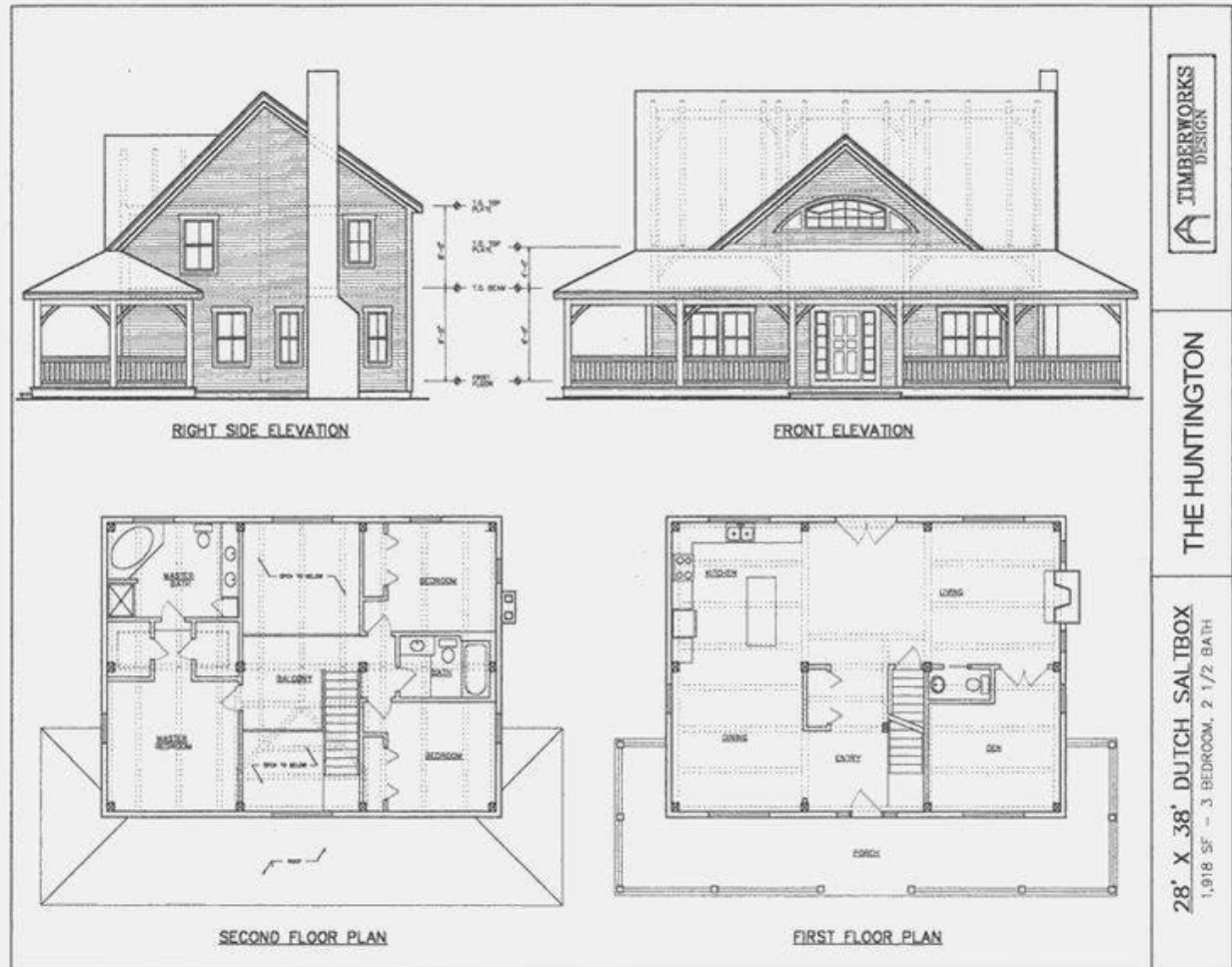

### Notes:

1. Attic access to be readily accessible. Minimum size 22" x 30" with 30" unrestricted headroom.
2. Handrails shall be provided on two side openings and continuous on one side only. Handrail shall be 34" above nosing of tread and shall be continuous the full length of the stairs and the ends shall return to the wall or shall terminate in a Newell post.
3. Fire block stairways between stringers and along run between studs.