

Electric Conversion Made Easy

- Insider Secrets Revealed -

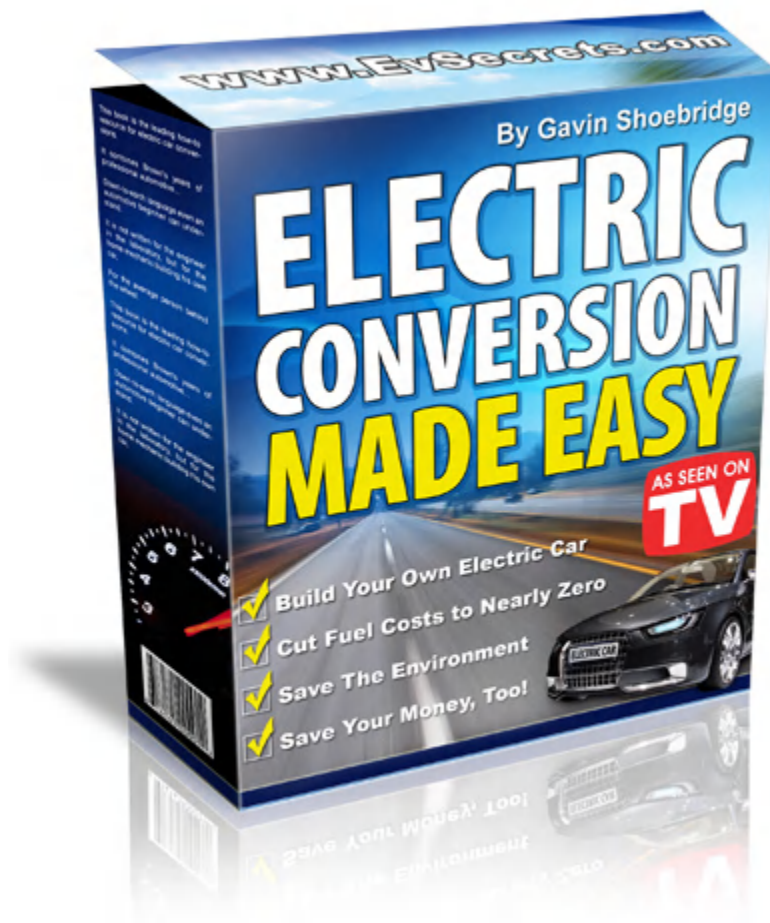

THIS IS NOT A FREE EBOOK

You DO NOT have the rights to reprint, resell, giveaway, share or distribute this ebook in anyway. Unauthorized redistribution, reprint or use is strictly prohibited.

© Copyright www.evsecrets.com

ALL RIGHTS RESERVED

No part of this ebook may be reproduced or transmitted in any form whatsoever, electronic, or mechanical, including photocopying, recording, or by any informational storage or retrieval system without expressed written, dated and signed permission from the author. All copyrights are reserved.

DISCLAIMER AND/OR LEGAL NOTICES:

The information presented herein represents the view of the author as of the date of publication. Because of the rate with which conditions change, the author reserves the right to alter and update his opinion based on the new conditions. The ebook is for informational purposes only. While every attempt has been made to verify the information provided in this report, neither the author nor his affiliates/partners assume any responsibility for errors, inaccuracies or omissions. Any slights of people or organizations are unintentional. If advice concerning legal or related matters is needed, the services of a fully qualified professional should be sought. This ebook is not intended for use as a source of legal or accounting advice. You should be aware of any laws which govern business transactions or other business practices in your country and state. Any reference to any person or business whether living or dead is purely coincidental.

If you obtained this ebook from anywhere else other than www.evsecrets.com, you have a pirated copy.

Please help stop Internet crime by reporting this to:

<http://www.evsecrets.com/support/>

I recommend you print this eBook, for more enjoyable reading - plus maximum convenience while working in your garage.

Table Of Contents

| | |
|---|------|
| Introduction..... | p.6 |
| Why Did I Write This Ebook..... | p.7 |
| How Does An Electric Car Work..... | p.12 |
| Differences Between An Electric Car And A Gas Powered Car..... | p.12 |
| Other Benefits Of Driving An EV..... | p.13 |
| The Main Components Of An EV..... | p.14 |
| Electric Motor..... | p.14 |
| Controller..... | p.15 |
| Battery | p.16 |
| Gearbox Adapter Plate..... | p.17 |
| Pot-Box (potentiometer box)..... | p.18 |
| Main Cable..... | p.19 |
| Circuit Breaker..... | p.20 |
| Fuse designed for electric vehicles..... | p.21 |
| Vacuum Pump..... | p.22 |
| Contactors..... | p.23 |
| DC to DC Converter..... | p.24 |
| Volt Meter & Amp Meter..... | p.25 |
| Shunt..... | p.26 |
| Inertia Switch..... | p.27 |
| Chapter#1 - Deciding Your Electric Car Needs & Budget..... | p.31 |
| Range..... | p.32 |
| Speed..... | p.32 |
| Conversion Cost..... | p.33 |
| Deciding Your Range Needs..... | p.34 |
| Deciding Speed And Voltage Requirements..... | p.35 |
| Deciding Your Budget..... | p.35 |
| 48 Volt System..... | p.36 |

| | |
|--|-------------|
| 96 Volt System..... | p.36 |
| 114 Volt System..... | p.37 |
| Early Cost Reduction Options..... | p.38 |
| Chapter #2 - Selecting a Donor Car..... | p.39 |
| 48 Volt Donor Cars(examples)..... | p.40 |
| 96 Volt Donor Cars(examples)..... | p.42 |
| 114 Volt Donor Cars(examples)..... | p.44 |
| Aerodynamics..... | p.46 |
| Where to buy Seized Cars – Up to 95% OFF..... | p.48 |
| Chapter #3 - Selecting The Parts & Batteries..... | p.49 |
| Capacity..... | p.49 |
| 6 volt batteries..... | p.51 |
| 8 volt batteries..... | p.52 |
| 12 volt batteries..... | p.51 |
| Other Battery Alternatives..... | p.54 |
| Selecting The Controller..... | p.55 |
| Selecting The Motor..... | p.56 |
| About DC Motors..... | p.57 |
| Shunt-Wound Motors..... | p.59 |
| Series-Wound Motors..... | p.60 |
| Compound-Wound DC Motors..... | p.61 |
| Motor Direction..... | p.61 |
| New DC Motor Options..... | p.63 |
| Finding a Cheap Electric Motor..... | p.63 |
| EV Parts List..... | p.65 |
| Where To Buy New Parts..... | p.66 |
| Where To Buy Second Hand Parts..... | p.66 |
| Chapter #4 Dismantling the Donor Car..... | p.67 |
| Tools You'll Require..... | p.68 |
| Clean Out Your Garage In Preparation..... | p.68 |
| Take Photos..... | p.69 |
| Label All Wiring..... | p.69 |

| | |
|--|--------------|
| Draining The Fluids..... | p.70 |
| Separating The Engine From The Gearbox..... | p.71 |
| Removing The Gas Tank..... | p.72 |
| Sell Those Old Parts..... | p.72 |
| Removing The Gearbox..... | p.73 |
| Chapter #5 Planning The Location Of Components..... | p.74 |
| Chapter #6 Installing the Motor..... | p.79 |
| Chapter #7 Installing the Controller..... | p.89 |
| Chapter #8 Installing The Components..... | p.93 |
| Connecting The Potbox..... | p.93 |
| Meter Installation..... | p.95 |
| Fuse Installation..... | p.95 |
| Circuit Breaker Installation..... | p.96 |
| Inertia Switch Connection & Installation..... | p.96 |
| The Accessories Battery & DC to DC Converter..... | p.96 |
| Building Your Own DC To DC Converter..... | p.97 |
| Vacuum Brake System Installation..... | p.101 |
| Power Steering Options..... | p.102 |
| Air Conditioning Options..... | p.104 |
| Chapter #9 Installing a Heater..... | p.105 |
| Chapter #10 Installing the Batteries..... | p.112 |
| Chapter #11 Wiring Up The Batteries..... | p.118 |
| Chapter #12 Powering Up Your Electric Vehicle..... | p.123 |
| Component Checklist..... | p.128 |
| Chapter #13 Installing Your Charging System..... | p.133 |
| Mains Powered Pack Charger..... | p.133 |
| Trunk mounting or external mounting?..... | p.134 |
| Using the One-Charger-Per-Battery Method..... | p.136 |
| Chapter #14 Preparing Your Electric Car For The Road..... | p.139 |
| Preparing Your EV For Inspection..... | p.139 |
| How To Get Your EV Insured..... | p.140 |
| What happens if I get stuck and need help..... | p.141 |

Introduction



Hi, my name is **Gavin Shoebridge** and with the help of this ebook you'll be driving gas-free in just a few months.

First of all, I want to thank you for purchasing this ebook. You've already taken the first step towards being independent from gasoline from your general daily driving.

Take a moment to imagine driving past the gas station on your way to the mall or on the way to work, keeping that money in your pocket instead of handing it over for gas.



It's a satisfying feeling. I know this because I've already converted a car to run on electricity. I also know that you already have the necessary skills to convert a car because I was a complete novice when I started; I could only just change my own motor oil!

Yup, a couple of years ago I decided to break my own oil addiction. I wanted to reduce the carbon I was creating by burning 20 gallons of gas each week. I also wanted to slash my transport costs right down.

I had 2 choices: I could either ride a bicycle everywhere come rain or shine, or I could take an existing gas car and convert it to electricity. If you're anything like me you enjoy riding a bike, but you just can't beat a car for convenience, especially when it's raining. ☺

Why Did I Write This Ebook?

You may be wondering what motivated me to write this ebook.

I actually have a couple of reasons:

- Everyone I've met who has converted their car to run on electricity wants to tell you about their conversion and show you their work. I'm no different; I want to tell you my story as well.
- However, I *also* want to show you exactly *how* it's done in a step-by-step fashion so that you can do it too.

I want to show you *how easy it is to convert a car to run on electricity*. A car that will achieve highway speeds if you desire. A car that can go for 100 miles if you so wish. A car that looks *normal*. Not only is it possible - it's actually very easy to do!



The picture above is the car I converted. It's what I'd consider an **"average electric car"**. It had an average top speed of approximately 85 mph, an average range of approximately 35 miles and an average cost of around \$6000 USD.

Don't worry if this sounds out of your price range though. Depending on your needs, location and creativity, you can quite easily cut this bill in half or even less. We'll get to all that later. Firstly, let's talk about what an electric car is.

This is an electric car:



So is this:



And this:



Ahh, this isn't:

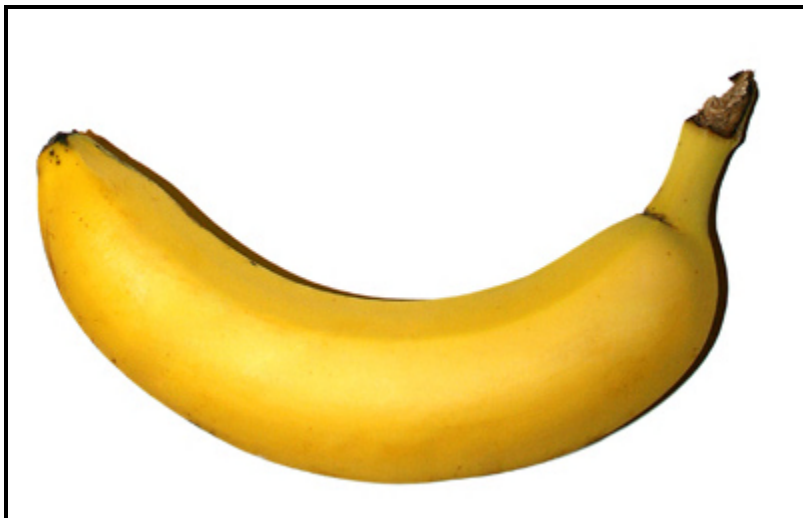

But this is:



And so is this:



So as you can see, electric vehicles come in all shapes and sizes. Some electric cars are seriously cool, such as the *Tesla Roadster*:



And some are, well, more functional, such as the *City El*:



How Does An Electric Car Work?

An electric car uses electricity stored in batteries to turn an electric motor which turns the wheels. This is similar in concept to using gas stored in a tank to turn an engine. What are the main parts in an electric car? Not a lot to be honest.

The 3 main parts your EV needs to run are:

- #1** An electric motor which powers the wheels,
- #2** Batteries which store the electricity, and,
- #3** A controller which acts as a floodgate between the batteries and the motor and is attached to your accelerator.

There are a few other bits such as fuses, a circuit-breaker in case of emergency, a contactor to “start” the car's main circuit, a vacuum pump to keep your brake system working (covered in Chapter #7), and some relays to keep items such as your heater and your Controller's key-ignition switch operating.

Differences Between An Electric Car And A Gas Powered Car

a) Firstly, there's much less noise and vibration because there's no engine running. People that aren't used to electric cars get a surprise when you pull up at the lights. Stopping in an electric car is a bit like going to rap concert: you know you're *there* but you just don't really feel or hear anything. Unless you *like* rap music of course in which case I apologize!

b) Secondly, there's almost zero maintenance in an electric car, which means no maintenance costs! You may find yourself topping up the water in your batteries every couple of months (depending on what batteries you use), but otherwise there's no oil changes, no filter replacements, no servicing, no spark plugs, no radiator repairs, no exhaust repairs, no belts, pulleys and fluids to change and best of all - no more gas! In fact the only time you'll have to go to a gas station is to put air in your tires. *Sounds good, huh?*

Are There Other Benefits Of Driving An EV?

There certainly are. Sure, it's quieter and more reliable than a gas-powered car but there are still more important reasons to "**go electric**":



Energy independence is one enormous reason. An electric car is not at the mercy of oil supplies and oil prices originating from the Middle East. Every mile you drive is powered by locally produced electricity from your own country.



Pollution reduction is another huge reason. Even if your electric car is charging from coal-fired electricity, the Co2 emissions per mile are approximately 70% cleaner (based on several studies) than that of a gas-powered car. If your electricity comes from natural gas, solar, geothermal, hydro or even nuclear then it's even cleaner still. Electric cars also emit no smog or fumes from an exhaust. Just imagine sitting in a traffic jam and breathing only fresh air!



Electric cars save you money. One electric vehicle manufacturer said recently that if you're paying more than \$1 per gallon then it works out cheaper to drive an electric car! It costs literally pennies per mile. This is due to the high efficiency of electric motors: \$1 worth of electricity will move you much further than \$1 worth of gas.



Electric cars have the benefit of high reliability due to a lack of things to go wrong. You'll never have to repair your exhaust or replace a radiator. You'll never need servicing or spark plugs replaced. No more belts or pulleys, no more air filters or fuel filters, no more fuel injection problems or oil changes – the list goes on and on. It all adds up to less expenses which means more money to spend on yourself instead.



You also have the benefit of recharging your car at home. If you're anything like me, having to work the gas station into your journey every time your car gets thirsty is a real pain in the neck. Then there's the waiting for an available pump, then the queue at the cashier. With an electric car however you can charge your car at home so it's always "full" and ready to go as soon as you jump in.

Don't be scared off by misinformed claims that electric cars have a limited range or top speed – the only thing limiting you from owning an electric racing car is your budget & needs which is what we'll discuss in chapter #1.

The Main Components Of An EV

Let's run through the necessary components in an EV and I'll explain what each one does.

Electric Motor



This one's kinda obvious; it's the **motor which propels the car**. The beauty of the electric motor is that it has only one moving part, unlike the internal combustion engine which has around a hundred moving parts. This alone makes electric vehicles a very reliable transport choice.

Controller



This is a controller.

Its job is to act as a floodgate between the motor and the batteries. It's indirectly connected to your accelerator and the more you press down, the more power goes to the motor. This is a vital component – without it you'd have either full power or no power.

Battery



I'm sure you can guess what that is!

Yup, it's a **battery**! Batteries are your car's substitute for a tank of gas. The more battery capacity available, the more range you get per charge! This is one area you need to consider carefully before purchasing - a quality pack of batteries will last many years if looked after well.

Gearbox Adapter Plate



This is a **Gearbox Adapter Plate** – a piece of metal that will join your electric motor to your car's existing gearbox. Car gearboxes are not designed to have electric motors bolt straight on, so an adapter plate like this is required.

Pot-Box (potentiometer box)

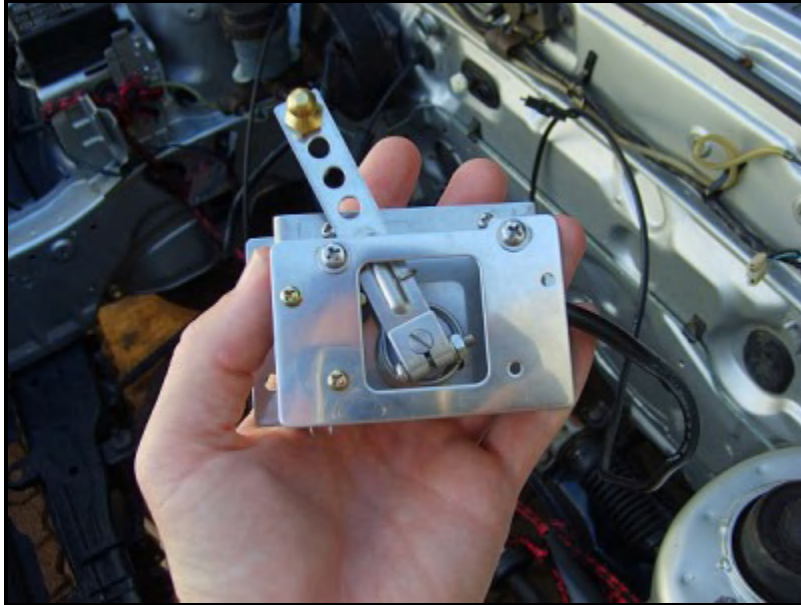

This is called a **Pot-Box** (short for potentiometer box) and is the device that your accelerator cable connects to. When you push down on the "gas", the arm moves and the device tells the Controller how much power to allow to the motor.

Main Cable

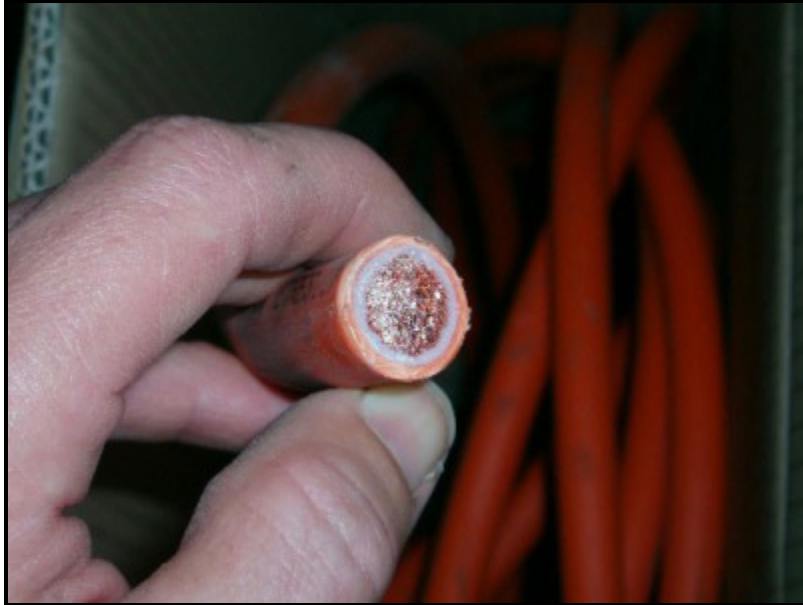

This is the **Main Cable** which will effectively be your car's new "Fuel line". It's important to get the right sized cable depending on the current that your car will use. Using a cable too small will cause it to heat up under load, increasing its resistance and choking your performance and increasing the risk of fire.

Circuit Breaker

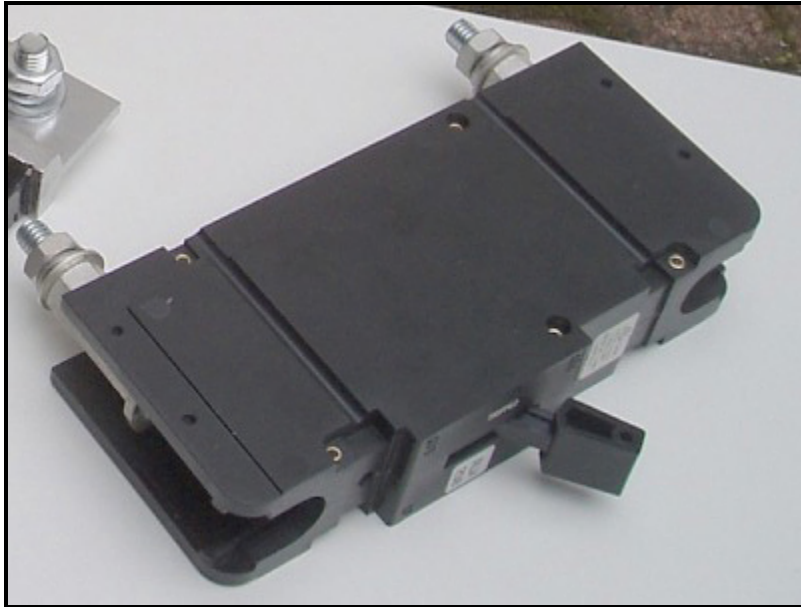

This is a **Circuit Breaker** – a safety switch designed to switch off in the event of a short-circuit or accident that causes a battery overload. It's convenient and also resettable unlike fuses.

Fuse designed for electric vehicles



This is a **fuse designed for electric vehicles** which is a backup to the circuit breaker. The average conversion uses at least two fuses for safety. These are designed to break during in an overload or short circuit. They generally cost about \$30 to replace.

Vacuum Pump



This is a **vacuum pump** and it creates a vacuum for your brakes to work. Gas engines create vacuum inside as a byproduct which is used to operate your car's brakes. Electric motors don't create any vacuum so a separate pump is required. Without it you'll find yourself in a bush on the first corner!

Contactor

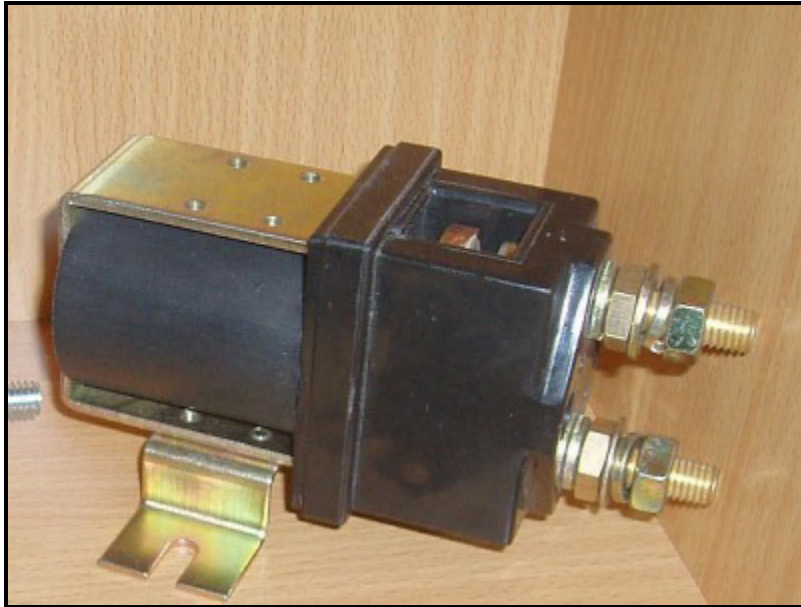

This device is called a contactor. When you turn the key on your EV, this device clicks the circuit "closed" (alive), allowing the high voltage circuit to operate.

Contactors like these are magnetized so that in an emergency, you simply turn the key off and the contactor pops the circuit "open" (dead).

DC to DC Converter



This is called a **DC to DC Converter**.

It converts your car's high voltage drive system down to 12 volts to keep your normal car battery and basic electrics working. Without one of these, the battery that operates the 12 volt stuff (headlights, turn signals, radio etc) would go flat. This keeps it charged up in case you need hazard lights etc for an emergency. This particular photo shows a standard computer power supply before it was modified it to become a DC to DC Converter – saving \$100 US! (this cost-cutting option is explained in Chapter #7)

Volt Meter & Amp Meter



Shown are a **Volt Meter and an Amp Meter** (aka *Ammeter*). A volt meter is effectively your gas gauge. There are many different volt meters available from basic volts-only meters, to high-tech volt meters that can determine how much range you have left. An ammeter tells you how much current (power) you're using at any given time. This will help you learn how to best drive your EV to maximize range. To use an ammeter in an EV, you need a "shunt".

Shunt

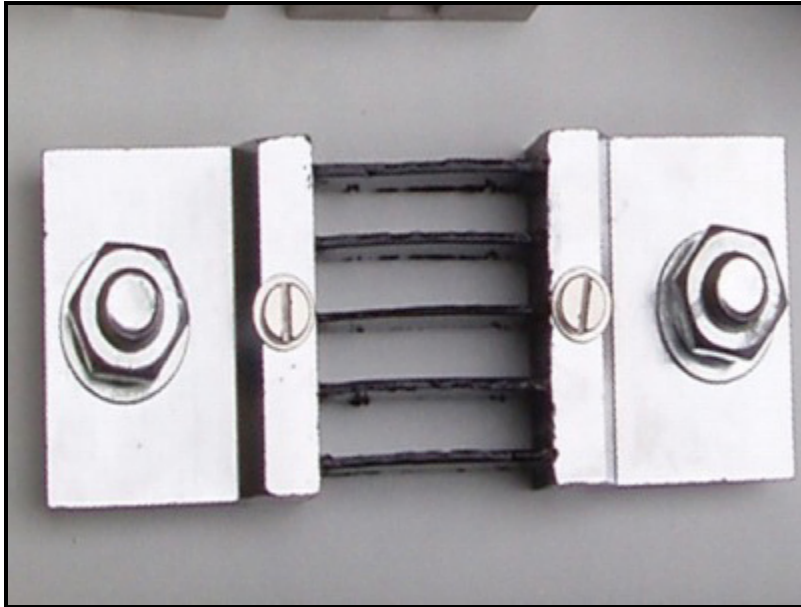

This silver device is a "**shunt**". This takes the high voltage & current flying through your cables and converts it to something a meter can read. Without one of these your *ammeter* would overload and you'd be victim to those pesky impromptu dashboard fires. In-car fires are great conversation starters but rather dangerous and best avoided.

Inertia Switch



This is an **inertia switch**. In the event of a collision, this device kills the main circuit by the sudden movement of a magnetized ball-bearing inside. It works in the same way as an airbag sensor and can be reset by pressing the top of the device. It's not always required by law, but I recommend it nonetheless.

That's it! Not much to it, right?

Those are all the basic components in any electric car. When you put them altogether, your car's engine bay will be transformed from something resembling this:

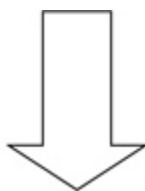

To something a little more like this:



**As you can see there's a little bit more space
without the engine, and a lot less to fix!**

- ⊘ No fuel injection computers.
- ⊘ No exhaust gas detectors.
- ⊘ No ignition timing computers.
- ⊘ No more oily hands and waste engine oil.

"The simplicity of electric cars is simply fantastic!"

Now you have a basic idea of what goes into an EV, so roll up your sleeves and let's get started!

In the first chapter we're going to cover the big choices which your EV will be based on. Although it may sound boring, the **best EVs are those done to a plan.**

Before we begin with *Chapter#1* however, let me congratulate you again. You've taken a brave step. A step that thousands every year are taking in their own garages. It's people like you who can wait no longer for car makers to produce electric cars and have instead decided to act ourselves because we have nothing to lose and so much to gain!

So let's crack into it and figure out your needs and budget.

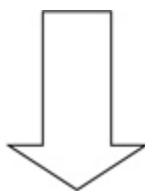

Chapter#1

Deciding Your Electric Car Needs & Budget

Typically when it comes to converting a vehicle to electricity, you have 3 main options:

- ✓ **A good range.**
- ✓ **A high top speed.**
- ✓ **A low conversion cost.**

Realistically though, you can only choose 2 of those 3 things.

This means that before selecting your parts or selecting a donor car, you need to decide what your goals are.

Range

When most EV owners talk about **range**, they mean the distance from a full charge to absolutely flat, or around 100% DOD (Depth of Discharge).

The **typical home-converted car** with common lead-acid batteries often has an *average* range of approximately **40 miles**. This is due to a combination of factors, the largest being the size & weight of the battery pack. Other contributing factors are aerodynamics and driving style.

Keep in mind that estimation of a 40 mile range is often based on draining your batteries flat - which is in the case of Lead Acid batteries is quite damaging and not recommended.

This means to achieve a *usable* range of 40 miles with Lead Acid batteries, you need a pack that could actually reach 80 miles – and that's a lot of lead!

However with the different EV options, battery technologies and suppliers available to us nowadays, the only thing limiting your EV's range is battery pricing.

For example, a home-converted EV with a range of **200 miles** is possible with off-the-shelf technology – as long as you're prepared to pay for it! We'll cover battery choices in Chapter #3.

Speed

How fast can an electric car go? As fast as you want! Unlike long range, a high top speed can be achieved without too much extra cost. It all depends on how much power is available from your car's battery pack and how much power your car's controller will allow through to the motor.

I've found a rule of thumb with estimating speed is by looking at your car's system voltage:

- *A car running on a 48 volt system will reach around 48km/h (30mph).*
- *A car running a 96 volt system will reach 96km/h (59mph).*
- *A car with a 144 volt system can theoretically reach 144km/h (89mph).*

Of course this is not a terribly scientific rule as many variables come into consideration such as aerodynamics, battery power, and weight.

For example, there are 72 volt cars that can achieve 100km/h (62mph) quite happily. Even so, this general rule should give you an idea on why the voltage of your conversion is important for your top speed.

Conversion Cost

The overall cost of the conversion can and will vary from car to car, and country to country.

The main things that could affect your overall costs are:

- Shipping and freight costs due to your location in the world.
- The strength of your currency for buying parts from overseas sources.
- Labor costs to fabricate battery racks and a motor-to-gearbox adapter plate.
- Welding things or crimping battery cables etc that many converters pay to have completed.
- How often you take your wife/husband/partner/pet out to dinner to compensate for all the time spent in the garage.



If you're handy with a welder or know how to cut metal and drill holes, you can knock about \$1000 off the conversion already!

I found that using tradesmen to create battery racks and adapter plates guaranteed a job well done, but it soaked up useful funds and took up valuable time. You can decide what you want to tackle yourself and what needs to be outsourced as we approach each step.

Deciding Your Range Needs

When working out your range requirements ask yourself:

- *How far will I need to drive each day?*
- *Am I going to use the car for a work commute or for unpredictable use?*
- *Is my driving terrain hilly or flat?*
- *Is there a recharging point at my work or destination?*
- *Is my choice of donor car a big heavy truck, or a small hatchback?*

If you're unsure of the distances, try recording them on your car's odometer or on a GPS system to give you an idea.

Alternatively **Google Maps** will be able to determine the distance by typing in the start and finish locations here: <http://www.maps.google.com/>

If your driving conditions are very hilly, expect to use twice the power whilst in those conditions. As a safety net, write down *double* the actual miles you drive in very hilly conditions.

If you plan on using a larger vehicle as opposed to a smaller car or hatchback expect to lose more range through the extra weight you'll be pushing around.

Also allow for any unplanned diversions (within reason) on your drive to avoid "range anxiety".

By considering all of the above you should now have a rough idea of how many miles you need to design your conversion for.

Deciding Speed And Voltage Requirements

This one's a bit easier! **Do you need to fly along the highway briskly or is speed not a priority for you?**

We all watch the advertisements on TV of shiny new cars flying down empty city streets but in the reality of rush hour you might be lucky to actually get *near* the speed limit. Keep this in mind because like a useful range, a higher top speed costs more! In almost all cases, good acceleration comes with a higher top speed.

For the purposes of simplification, I'm going to concentrate on 3 common voltage choices throughout the ebook and 3 different vehicle sizes to give you an idea of voltage and vehicle size for your own conversion.

Deciding Your Budget

The examples below will give you an idea of what top each voltage (relative to top speed) costs with new parts. These are estimated averages in US Dollars taken from existing EV suppliers' price lists for brand new parts. These prices exclude shipping & taxes and are subject to change constantly.

We'll discuss the many different battery choices later but for the time being - *batteries not included*.

Here are the necessary components for 3 common voltage conversions.

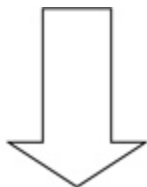

48 Volt System

| | |
|------------------------------------|-------|
| • Advanced DC Motor #A00-4009 | \$700 |
| • Controller Curtis 1209B-6402 | \$900 |
| • SW-200CW Main Contactor | \$137 |
| • High Voltage Fuses & Holders (2) | \$180 |
| • 160V DC 250A Circuit Breaker | \$100 |
| • DC to DC Converter* | \$100 |
| • Curtis PB6 Pot Box* | \$90 |
| • Gearbox/Motor Adapter Plate* | \$850 |
| • Motor mounts* | \$200 |
| • Battery Rack Fabrication* | \$400 |
| • Thomas Vacuum Pump & Switch* | \$300 |
| • DC Voltmeter* | \$30 |
| • DC Ammeter + Shunt* | \$50 |
| • 70mm2 or 00 AWG Main Cable 12m* | \$200 |
| • Inertia (Crash) Cutoff Switch* | \$80 |

Total cost of essential new parts & fabrication: **\$4317**

96 Volt System

| | |
|------------------------------------|--------|
| • Advanced DC K91-4003 Motor | \$900 |
| • Controller Curtis 1221C-7401 | \$1300 |
| • SW-200CW Main Contactor | \$137 |
| • High Voltage Fuses & Holders (2) | \$180 |
| • 160V DC 250A Circuit Breaker | \$100 |
| • DC to DC Converter* | \$100 |
| • Curtis PB6 Pot Box* | \$90 |
| • Gearbox/Motor Adapter Plate* | \$850 |
| • Motor mounts* | \$200 |
| • Battery Rack Fabrication* | \$400 |
| • Thomas Vacuum Pump & Switch* | \$300 |
| • DC Voltmeter* | \$30 |
| • DC Ammeter + Shunt* | \$50 |
| • 70mm2 or 00 AWG Main Cable 12m* | \$200 |
| • Inertia (Crash) Cutoff Switch* | \$80 |

Total cost of essential new parts & fabrication: **\$4917**

144 Volt System

| | |
|---|--------|
| • Advanced DC FB1-4001A Motor | \$2000 |
| • Curtis #1231C-8601 | \$1600 |
| • SW-200CW Main Contactor | \$137 |
| • High Voltage Fuses & Holders (2) | \$180 |
| • 160V DC 250A Circuit Breaker | \$100 |
| • DC to DC Converter* | \$100 |
| • Curtis PB6 Pot Box* | \$90 |
| • Gearbox/Motor Adapter Plate* | \$850 |
| • Motor mounts* | \$200 |
| • Battery Rack Fabrication* | \$400 |
| • Thomas Vacuum Pump & Switch* | \$300 |
| • DC Voltmeter* | \$30 |
| • DC Ammeter + Shunt* | \$50 |
| • 70mm ² or 00 AWG Main Cable 12m* | \$200 |
| • Inertia (Crash) Cutoff Switch* | \$80 |

Total cost of essential new parts & fabrication: **\$6317**

Items with an asterisk () are very similarly priced and often interchangeable with any voltage.*

Note: Don't forget, I've left out batteries at this stage as it's a whole other chapter – literally!

Early Cost Reduction Options

Are you looking to cut these costs down? You could consider trying an in-between voltage such as a 72 volt system or a 120 volt system. Also consider buying a conversion kit with everything in it from a supplier to save on individual shipping costs.



Also, as I'll mention many times throughout the ebook, *bargains* are to be found everywhere from <http://www.eBay.com> to your local wreckers yard. There are even things you can do yourself to avoid paying for new items such as:

- *using multi-meters instead of in-dash voltmeters*
- *computer power supplies instead of DC to DC Converters.*

I've seen a lot of creativity used with electric cars to cut costs and I'll mention it all as we approach each step.

I've listed only *Advanced DC motors* and *Curtis Controllers* in my lists because I've seen overwhelmingly positive responses from EV converters using them, but by all means shop around.

There are many other (and often cheaper) motor and controller options available out there. Check out your local EV club for bargains too – someone's bound to be selling what you need second hand.

As you'll find out, the more creative you are, the more ways you'll find to eliminate the above costs by welding battery racks yourself, crimping the ends of the main cables yourself or fabricating your own motor mounts and adapter plate to join your electric motor to your car's gearbox.

Don't be scared off the idea of an EV just yet – it's not as hard as it sounds!

Chapter #2

Selecting a Donor Car

This is where it starts getting fun - you have a world full of car makes and models to choose from!

So what makes a good donor car?

The main strength of any donor car is its ability to carry the weight of your battery pack without exceeding the car's legal limitations. If your voltage or battery pack is small or light then you have more choice of vehicle, but less range or speed.

To simplify things at this early stage I'm going to assume you're using a medium sized lead-acid battery pack – the most common choice because of their affordability.

When choosing a donor car, make sure you check out the **GVWR** (Gross Vehicle Weight Rating) to see what the maximum load the car can handle. This sort of information can be found on Google by making your search specific with the key words in "speech marks", such as: "1995" "S10" "GVWR". This will bring up only the results with exactly those words in them, making it easier than trawling through hundreds of pages.

Often the weight of your battery pack is relative to your voltage. After chapter#1 you should have an idea of what voltage will suit your performance needs so to give you an idea of voltage/battery pack weight, let's use the **Trojan SCS200 12 Volt battery at 60 lbs** (27 kg) each as an example:

Example: Trojan SCS200 12 Volt battery at 60 lbs (27 kg)

48 Volt System (4 x SCS200 batteries connected in series): 240 lbs (108 kg)

96 Volt System (8 x SCS200 batteries connected in series): 480 lbs (216 kg)

144 Volt System (12 x SCS200 batteries connected in series): 720 lbs (324 kg)

Of course these are only average figures to help you comprehend what weight you're likely to deal with. We'll cover battery specifics and more accurate weights in chapter#3. For now though, let's go hunting for donor cars, starting with 48 volts.

48 Volt Donor Cars

Due to the limited power output of a 48v system, you need to keep the weight of the vehicle as low as possible. A very **small hatchback** is the ideal choice.

Here are **3 examples** of cars that would suit a 48v system

- *1995 Mitsubishi Mirage*
- *1995 Suzuki Swift/Geo Metro*
- *2002 Smart ForTwo*

48 Volt Donor Car



1995 Mitsubishi Mirage:

The *GVWR* of this car is 3590 lbs(1630 kg) which is good, but the car itself is rather heavy for it's size which will restrict your top speed, acceleration and range with a 48v system.

48 Volt Donor Car



1995 Suzuki Swift/Geo Metro:

Fitting 4 batteries into this little beast won't be a problem and it won't strain the chassis of the car as it's GVWR is 2929 lbs or 1329 kg, although you must take into consideration the weight of passengers too.

48 Volt Donor Car



2002 Smart ForTwo: Although we're starting to get very small, this little car would still take the weight of the batteries, plus 2 adults. It's getting close to the GVWR of 2314 lbs or 1050 kg but you'd get quite respectable performance from a low-voltage system in a car this small.

96 Volt Donor Cars

Now we have more choice because of the extra power, but more compromise because of the extra weight!

Fitting approximately **480 lbs(216 kg)** into a car with 4 adults could exceed the limits of the GVWR in some cars so although you have more power, you have to look carefully.

96 Volt Donor Car



The “Classic” Volkswagen Beetle: This iconic car has been converted to electric with 96v systems many times in the past and because its engine is in the trunk it has a large amount of space available for batteries in the front of the car. Its GVWR is 1873 lbs or 850 kg. There are many conversion kits available for this car.

96 Volt Donor Car



1999 Suzuki Vitara

Small cars from the late 90's like this example can be quite light – but often due to the lack of safety features. On the down side it typically means you act as a crumple zone, but on the up side the weight savings are convenient. If you can get past the look of the thing. This car has a GVWR of 3373 lbs or 1529 kg.

96 Volt Donor Car



2003 Toyota Matrix

This is as large and heavy as I'd recommend with a 96v system in order to keep respectable performance. The GVWR of this car is 3800 lbs or 1723 kg.

114 Volt Donor Cars

We're now talking about a voltage that has the potential to move a large vehicle quite easily, though I still recommend looking for the lightest, smallest vehicle possible – as long as it can handle the weight of your batteries. Unfortunately, small cars that will take that weight - as well as a full payload of people - aren't very plentiful and you might want to consider a utility or pickup truck.

114 Volt Donor Car



1996 Chevrolet S-10

It's a very popular choice for 144v systems. The Chevrolet S10 will take 720 lbs without breaking a sweat – in fact with this vehicle you could get away with doubling the size of your 144 volt battery pack! It has an impressive GVWR of 5150 lbs or 2336 kg.

114 Volt Donor Car



1992 Nissan Navara

Once again, a utility or small truck like this is fairly light for it's size but can take an impressive payload. The GVWR of this car is 5666 lbs or 2570 kg.

114 Volt Donor Car



2006 Scion XB

Cars such as the Scion XB can take a reasonable amount of weight for their layout and have previously been converted to electric by some high-budget converters. AC Propulsion even sells a car based on a converted Scion XB. This model has a GVWR of 3370 lbs or 1528 kg.

Please note: I've obtained all GVWR figures from various automotive websites and can't guarantee their accuracy. Treat them as a guide only. The service department of your local car model dealer should be able to double check your car's exact GVWR for you.

Aerodynamics

This plays quite a large part in your final range. Having good aerodynamics can improve your car's range by up to **30%** more in some cases.

Unfortunately finding aerodynamic specifications for older cars on the Internet isn't easy but a good rule of thumb is this: ***If it's shaped like a jellybean, it's aerodynamic!***

Like all rules of thumb, it's not always accurate but it'll give you an idea on aerodynamics. Popular aerodynamic modifications are covered in detail in the bonus ebook "***Getting the most out of your EV***" which is included with this ebook.



If you've found a potential donor car for your conversion, you need to check a few essentials:

- Firstly, **does it have any rust?** The life of my own EV was cut short because of rust and my own "*I'm sure I can fix it*" attitude. Learn from my error and try to find a car without rust.
- Be sure to **check the sills** of the car and have a good look under the car in daylight. Don't be scared to get your knees dirty if it saves you from unnecessary rust repair and unplanned delay! My own conversion would have been on the road 3 months before schedule if it wasn't for the rust repair and painting I had to do. Here's a little phrase to keep in mind, "*Does the car have rust – buy it only if you must!*" It's a corny message but you get the idea. Buying a car without rust will save you time and money.

- Once again for the purposes of simplicity I'm going to recommend converting a **car with a manual or "stick shift" gearbox**, so make sure you look primarily for one of those. Cars with automatic gearboxes can be converted to electric, though it takes a fair amount of work and you lose a lot of efficiency. Automatic gearboxes are not designed for the torque range on an electric motor and will generally have to be reprogrammed to stay in a chosen gear, or only change at a particular motor speed. If you're not scared off by the extra work and you're familiar with automatic gearboxes then don't let that stop you, but for this ebook. I'm keeping it simple and recommending only a manual gearbox.

If you've found a car with a manual gearbox, be sure to check the condition of the gearbox. If the car is drivable, take it for a spin trying each gear. Does it pop out of gear? Does it make a crunching noise or whining noise in a particular gear? Does it resist going into a particular gear? These are signs of future trouble. Avoid donor cars with these symptoms if you can, unless you can track down a cheap replacement gearbox. My own donor car had gearbox problems which caused delay and extra cost.

- Does the donor car you're looking at have **power steering and/or air conditioning**? If so, this will require a little extra effort and cost to make these options work properly. We'll get to that in Chapter 8.
- With the donor car's weight limits, aerodynamics, and cost in mind, it's also important to make sure you **choose a car that you want to convert!** It's all very well converting the perfect vehicle to electric, but it should be a car you like the look of and want to be seen in!



Now that you have an idea of what makes a good donor car it's time to go hunting!

Seized Cars – Up to 95% OFF

Up to
95% OFF
Search Your
Gov't Seized Car
HERE >>>

Honda
MAKE

ZIP CODE

BEGIN SEARCH HERE

Here's an incredibly [popular website](#) for **government auctions** which claims to be the Internet's largest government auction service.

The website has [easy navigation](#) and plenty of features to help narrow down the ideal donor car for your conversion. You can do a [free search](#) for the type of car you want to buy in the state you live. You can also test the waters by viewing recently completed auctions with the prices they sold for. Compare these prices to the book value of the vehicle to get an idea of [how much you could save](#). The website is frequently updated and you get unlimited access instantly to details on thousands of auctions. It's impressive for bargain hunters and worth a look.

[CLICK HERE TO START THE SEARCH](#)

I think we've covered the basics in regards to finding a donor car so with that in mind, happy hunting!

Chapter #3

Selecting The Parts & Batteries

Decide on your batteries first, but buy the batteries last. This way you won't have expensive batteries lying around your garage self-discharging while you're busy working on other things.

Assuming you've decided on what voltage you'd like to run, now you must decide what sized batteries will make up that voltage. Chapter#1 gave you a taste on battery weight – now it's time for the gritty details.

We're going to stick to **Flooded Lead-Acid batteries** for simplicity, which gives us 3 main choices in battery size:

- **6 volt batteries**
- **8 volt batteries**
- **12 volt batteries**

Your batteries will be connected "*In series*", which means the negative terminal of one battery connects to the positive terminal of another. This way, two 12 volt batteries connected in series become a 24 volt pack; three 12 volt batteries become a 36 volt pack; and twelve batteries connected in series will create a 144 volt pack.

You can connect any battery in series to increase its collective voltage.

Capacity

Individual battery capacity is typically measured in "*Amp Hours*", or how many amps can be maintained for a set amount of hours.

This is important to know when deciding your batteries. Unfortunately Amp Hours or a/h depends on the battery voltage making it confusing when deciding which battery has more capacity.

For example, a 12 volt battery rated at 100 a/h, has the exact same capacity as a 6 volt battery rated at 200 a/h.

This can be confusing at times so to remove the confusion, convert the rating to "Kilowatt Hours" or *kWh* which will tell you the battery capacity regardless of voltage.

It's very handy and easy to do. Simply take the voltage (eg. 12), and the capacity (eg. 120) and multiply the two: $12 \times 120 = 1440 \text{ kWh}$. To work out the **kWh** of a car's entire battery pack simply increase the voltage in your equation (eg. $144\text{V} \times 100 \text{ a/h} = 14,400 \text{ kWh}$).

Try these examples:

- *Battery pack 1 has eight 6 volt batteries rated at 225 a/h each. What's the total capacity in kWh?*
- *Battery pack 2 has twelve 8 volt batteries rated at 170 a/h each. What's the total capacity in kWh?*
- *Battery pack 3 has twelve 12 volt batteries rated at 105 a/h each. What's the total capacity in kWh?*

Once you've worked those out, you'll have an understanding of how many kilowatt hours or kWh are in a battery or entire battery pack.

Answers:

Battery pack 1: 10,800 kWh.

Battery pack 2: 16,320 kWh.

Battery pack 3: 15,120 kWh.

See how battery pack 2 is only 96 volts but it has more capacity than battery pack 3 at 144 volts? This means that even though the *voltage* is lower in pack 2, it has more overall *capacity* than battery pack 3.

Having more capacity in pack 2 doesn't always mean having more range however as the 96 volt pack (2) would have to work much harder than the 144 volt pack (3) to match the same driving style, and as you'll learn, driving your pack harder reduces your range considerably.

This means choosing the correct voltage and capacity is equally important. With that in mind, let's demonstrate the differences in battery voltages, weights and costs using three common and reliable battery choices.

6 volt batteries

A typical 6 volt battery to consider would be the **Trojan T105**. It weighs 62 lbs (28 kg), has a storage capacity of 225 amp hours (1,350 kWh each), and cost approximately \$140 US each.

For their size, 6 volt batteries have the most capacity out of the three and a battery pack made up of 6 volt batteries can typically handle more deep discharging than a battery pack made up of 12 volt batteries.

The down side is the extra price of having double the amount of batteries, and the incredible amount of extra weight you'd be carrying around.

As an example, if you're going for a larger 144 volt system with 6 volt batteries you'd need 24 batteries at around \$3360 US – you'd also need a donor car that could happily take the 1500 lbs (680 kg) of extra weight, such as a *Chevy S10* or similar utility/pickup.

8 volt batteries

A typical 8 volt battery to consider would be the **Trojan T875**. It weighs 63 lbs (28.5 kg), has a storage capacity of 170 amp hours (1,360 kWh each), and costs approximately \$130 US each.

The 8 volt batteries are a good middle of the road choice. They offer a decent bang-for-buck while meeting halfway in weight between the 6 volt and 12 volt batteries.

Using the big 144v example, your pack would consist of 18 of these batteries at around \$2340 US and weighing 1134 lbs (514 kg).

12 volt batteries

A typical 12 volt battery to consider would be the **Trojan SCS150**. It weighs 63 lbs (28.5 kg), has a storage capacity of 105 amp hours (1,260 kWh each), and costs approximately \$130 US each.

As you can see, 12 volt batteries don't have the same capacity as their 6 and 8 volt

counterparts, but they are incredibly convenient in size and weight.

It means you'd only need 12 batteries connected in series to make a 144 volt battery pack for you car, costing approximately \$1560 US, and weighing around 756 lbs (342 kg).

You can see in this example the pack would be fairly lightweight (for a lead acid pack) giving you impressive acceleration but it's also low in capacity meaning you wouldn't have much range.

More Useful Tips:

Don't even think about using normal car "starting" or "marine" batteries for your conversion. They may be 12 volts, around the same size (and often cheaper) but they're only designed for short bursts of power, and then sitting on a charge again for the rest of the day. Running these batteries in an EV with the heavy, constant power demands would give you about 4 to 6 months of maximum life before those new batteries become big, acid-filled paperweights. Insist on only "**Deep Cycle batteries**", and if possible find others who have used the same batteries in their EV with success.



Looking to save money on batteries?

While it's often said, "*Never cut corners with your batteries*", if you're financially challenged you could look at a technique called Battery Rejuvenation.

Battery Rejuvenation is where you take old batteries which have worn out and lost their capacity, and by sending a high frequency pulse through the battery, break down the sulfation inside, bringing the battery to life again.

Speaking from personal experience I've found battery desulfating not completely reliable in every case but many others swear by it. There are some budget EVs out there that *only* use rejuvenated batteries! So, if you're desperate to get an EV and money's getting in your way then you could take a chance and give it a go!

Track down a forklift repairer, auto wreckers yard, or look in your local paper and see what batteries you can scrounge up for next to nothing (be sure to only look for Deep Cycle batteries though or you'll be back to square one in weeks).

Next step is to find a battery desulfator and desulfating solution from an auto parts store, or <http://www.eBay.com> and try it for yourself.

Before selecting your batteries, make sure you have the measurements so you can make them fit into your donor car.

I've found making cardboard mock-ups helps. Some have even found similar (dead) batteries that are the same size and removed the innards, giving them a real world indication of how it would look and fit.

Make sure you allow enough room above the batteries for the terminals to fit in. Allow a couple of inches between the top of the battery terminals and your battery box lid (if you have one) for connecting of cables and movement of air etc.

Last but certainly not least, try to buy your batteries as late in the project as possible. If you're buying shiny new batteries then preferably you should have bought your charger first so that your EV's most important parts won't sit around going flat - which would shorten their life.

Isn't there a precise method to figure out exactly what size batteries I need?

It's always going to be a calculated guess due to all the variations applicable on every conversion. Yet there are a couple of methods to make your guess a little more precise.

A very popular range-estimating web page for electric cars is this one:
<http://www.evconvert.com/tools/evcalc/>

It's been proven time & time again to be one of the best range calculators on the Internet as lists some popular battery & vehicle choices as well taking real-world driving into consideration. Of course every car is different and your results will vary depending on driving style and aerodynamic modifications.

Another way to help you decide on final battery capacity is to calculate the distance you can travel by other real world conversion stats.

Take a look at this example:

Let's say the average home converted EV uses 0.3 kW/h (kilowatts per hour) of electricity per mile at 35 miles per hour. This means to drive 50 miles at the same speed, you'll need approximately 15 kW/h of battery capacity available.

Remember that you should never take lead acid batteries past half-full which means you'll need a battery pack that is actually *twice* what you need (30 kW/h). With lead acid batteries a 30 kW/h pack is enormous!

For example if your car is running a 96 volt pack you can work out the battery amp hour requirements with the **watts÷volts=amps** formula:
30,000 W/h (30 kW/h) divided by 96 volts equals 312.5 A/h (amp hours)

This means a 96 volt car would need to use ten, 12 Volt, 312.5 A/h batteries (10x12v=96v), which (if they existed) might weigh around 176 lbs (80 kg) each. That's 1760 lbs (800 kg) which would exceed the limits of most cars except for some small trucks!

Remember that this entire calculation is purely an example which will change depending on your car's weight (including batteries), aerodynamic properties, driving style, and system voltage (the higher the system voltage the less hard the system has to work).

Other Battery Alternatives

- **Flooded Lead Acid batteries** are the ideal battery for beginners as they're cheap, but there are others out there to choose from.
- **Sealed Lead Acid (SLA)** batteries are another option which don't require topping up every 2 months and can be stored on their sides.
- The next step up would be the **Advanced Glass Mat (AGM)** sealed lead acid batteries. Being another kind of sealed lead acid battery they can be stored on their sides also but the glass mat inside allows these batteries to deliver higher amp bursts take a lot more abuse.

Sealed lead acid batteries have specific charging requirements however. Using a standard car charger on a sealed lead acid battery will cause it to bubble inside, reducing its lifespan. You'll need to talk to your supplier about finding a lower voltage *SLA* or *AGM* battery charger to avoid cooking your batteries.

- Next in the list are **Nickel Cadmium (Ni-Cd)** batteries which are hardy, reliable batteries able to handle deep discharging better than most batteries available and can even be stored empty without damage. Ni-Cd batteries have a much higher energy density than the *Lead Acid battery* range but due to the labor in manufacturing these batteries are often priced out of many converter's reach. *Ni-Cd batteries* also have specific charging requirements and can develop a "memory", as well as being quite toxic if disposed of improperly.
- Further up the battery food chain are **Nickel Metal Hydride (NiMH)** batteries. Unfortunately finding these batteries is a challenge as the patent for large NiMH cells is owned by Chevron who guards their patent closely. These were the batteries used in GM's infamous EV1 and also Toyota's Rav4 EV. They're good batteries for EV use but not usually available to consumers in large quantities. Until the patent expires (in 2015) and the batteries can be mass produced again, the next best EV-friendly battery in the food chain is the Lithium Iron Phosphate battery.
- **Lithium Iron Phosphate batteries (LiFePO4)**
While I'm covering Lead Acid batteries primarily in this book as they're cheaper for first time users, but there are other options such as the popular Lithium Iron Phosphate batteries. It's still a fairly new composition but one that's taking the EV world by storm. As with any new technology it's too young to have a history but so far I've heard a lot of praise from EV converters who've chosen this method.

While much more expensive, LiFePO4 batteries have many benefits over Lead Acid. They're maintenance free, much lighter, have a higher energy density per kilogram, and can be discharged to 80% DOD (Depth of Discharge), whereas Lead Acid can't go below 50%.

This means that ranges of 100 + miles are very possible with LiFePO4 batteries – if your budget allows it.

One downside to LiFePO4 batteries other than the high cost is that each cell requires a BMS (Battery Management System) attached to it. A BMS is a little

circuit which clips onto the battery's terminals and can regulate the current during charging to make sure all cells reach the same charged level.

With lead acid batteries this isn't a problem as lead acid batteries will self-equalize during the "overcharging" stage. LiFePO4 batteries require a little assistance however and without a BMS your shiny new lithium batteries will last only a matter of months before one cell's weakness starts to affect the pack's total performance. With a BMS it's expected a typical LiFePO4 pack should last approximately 7 to 9 years.

Most reputable battery suppliers will also ship out a BMS with your pack, although they are an extra cost.

Buyer beware!

The EV community certainly isn't free from scam artists and I have seen one converter lose several thousand dollars when the supplier vanished with his money so only buy from reputable sellers.

Find other converters that have used LiFePO4 batteries by searching battery types at www.evalbum.com through similar discussions at www.diyelectriccar.com and contacting the converters themselves.

I'm apprehensive to recommend any suppliers for LiFePO4 batteries personally, though I have seen positive feedback written about *Thundersky batteries*, for both their batteries and their customer service when things go wrong.

Whatever your supplier decision, do your research first and track down other customers from that supplier for their opinions.



Purchasing tip:

If you're buying LiFePO4 cells I recommend buying at least two spare cells with your order in case you have a faulty cell at some point. Not only will it mean that you're not off the road while waiting for a replacement, but quite often the chemistry changes inside the batteries so the battery you get back from the supplier may be different to the faulty one you sent back.

If you're interested in using any of the above battery chemistries, I recommend contacting your local battery supplier or doing a search for manufacturers on www.google.com

Selecting The Controller

For the purposes of this book I'm going to suggest *Curtis controllers*, as they're reasonably affordable and have a very low failure rate. There are many different controller brands available but as with anything, buyer beware!

If you're unsure of a particular controller brand, try to locate people who are already using it by using the "search by controller" function at www.evalbum.com. This will give you personal accounts of the different controllers available.

I recommend the following models of controller for your EV:

- **48 Volts:** Curtis 1209B-6402. 400 amps output, usable in a car with 48 to 72 Volts.
- **96 Volts:** Curtis 1221C-7401, 400 amps output, usable in a car with 72 to 120 Volts.
- **144 Volts:** Curtis 1231C-8601, 500 amps output, usable in a car with 96 to 144 Volts.

While they're often expensive, I still recommend buying a controller brand new with a warranty. This way you'll have somewhere to fall back on if things do go wrong or it doesn't work.

If you're looking at second hand parts then the internet is once again your best friend! If you find a deal on a controller I recommend asking someone at your local EV group or the people at www.diyelectriccar.com if it's suitable for your voltage and needs.



A popular choice for EV converters on a bargain hunt are forklift and golf cart controllers. You can normally track these down on www.eBay.com or your local paper quite cheaply. Unfortunately these are often only 48 volt controllers so not suitable for a 96 volt system, and especially not suitable for a 144 volt system unless you need a little excitement and a few sparks to brighten up your day.

Selecting The Motor

The motor is obviously one of the most important parts of your EV. Selecting the right one is as important as selecting the right batteries. It has to be able to push the load of the car without straining and overheating. One of the great things about DC motors is that they're quite flexible with voltages.

For example, I've seen cases where people have used 48 volt forklift motors in a 120 volt car without any problems.

If you're looking at using a new motor with a warranty, I've had good success with the brand "**Advanced DC**" and will be using them as examples in this ebook. There are many alternatives out there though so don't be scared to go hunting!

About DC Motors

The most common DC motors available are:

- **Shunt Wound,**
- **Series Wound**
- **Compound Wound motors.**

Here are the differences between each:

Shunt-Wound Motors

This type of motor tries to run at a constant speed, regardless of the load. It is the type generally used in lathes, drills, and process lines where starting conditions are not usually severe and is probably the most common DC motor used in industry today.

The components of the shunt motor are the armature (labeled A1 and A2) and the field (labeled F1 and F2). This motor provides starting torque that varies with the load applied and good speed regulation by controlling the shunt field voltage. In other words, the shunt motor will not over-spin and destroy itself if it loses its physical load.

While not as popular (mainly due to cost), these motors can still be used successfully in electric cars if you can find a suitable controller designed for shunt wound motor running at your voltage.

Series-Wound Motors

This type of motor speed changes compared to the load, increasing as the load decreases. The series wound motor has very poor speed control itself, and requires voltage and amperage control – which is what your controller is for. Series wound motors are excellent for use in electric cars because they are completely controllable. Series-wound motors should never be used where the motor can be started without load or with the car in neutral since they will over-spin and destroy themselves if given full power.

Components of a series motor include the armature (labeled A1 and A2) and the field (labeled S1 and S2). The coils inside the motor's *series field* are made of a few turns of large gauge wire to facilitate large current flow.

This means series wound motors can produce a high starting torque (approximately 2 ¼ times the rated load torque) which is perfect for moving 2 tonnes of electric car from a standstill!

Most DC controllers are designed to work with series wound motors. Series wound motors are the most popular motors used in home-converted electric cars.

Compound-Wound DC Motors

This is a combination of both the shunt wound and the series wound motor combining the characteristics of both. Characteristics may be varied by varying the combination of the two types of motor windings. These motors are generally used where severe starting conditions are met and constant speed is required at the same time.

When comparing the advantages of the series and shunt motors, the series motor has greater torque capabilities while the shunt motor has more constant and controllable speed over various loads. These two desirable characteristics can be found in the same motor by placing both a series field and shunt field winding on the same pole. Thus, we have the compound motor.

Common uses of the compound motor include elevators, air compressors, conveyors, presses and shears. The cost of these motors (and the lack of suitable controllers) puts these motors out of the reach of most converters.

Motor Direction

Some motors are designed to turn in one direction only. This can be a problem if your car's gearbox shaft turns the opposite direction to that of your motor (which is a common occurrence with some Honda vehicles).

“Is my motor easily reversible?”

If your motor has 4 terminals marked **A1**, **A2**, **S1**, **S2** then it's reversible. Two of these terminals are for the central spinning part called the *armature* (**A1 & A2**) and the other 2 terminals are for the fixed magnets inside called the *field* (**S1 & S2**).

A field-to-armature connection is required externally by using a heavy duty jumper cable between the terminals on the motor's surface (as seen in almost all conversions).

This means that if you jumper **A1 to S1** and apply power to the other two, the motor will rotate in one direction; typically counter-clockwise.

So by connecting a jumper between **A1 and S2**, then applying power to the remaining 2 terminals will cause the motor to rotate in the opposite direction.

If you have a motor with only two terminals where the field is connected to the brush internally, the motor will rotate the same direction regardless of the polarity connected to the two terminals and will require a specialist to reconfigure the motor internally in order to change its rotation.

Changing the motor's timing

Some motors have their *brushes* (the parts that actually touch the armature) manually configured to help the motor spin more in one direction than the other to increase efficiency. If you've changed the direction of the motor's rotation then you should check to see if your brushes are advanced to suit your motor's new rotation.

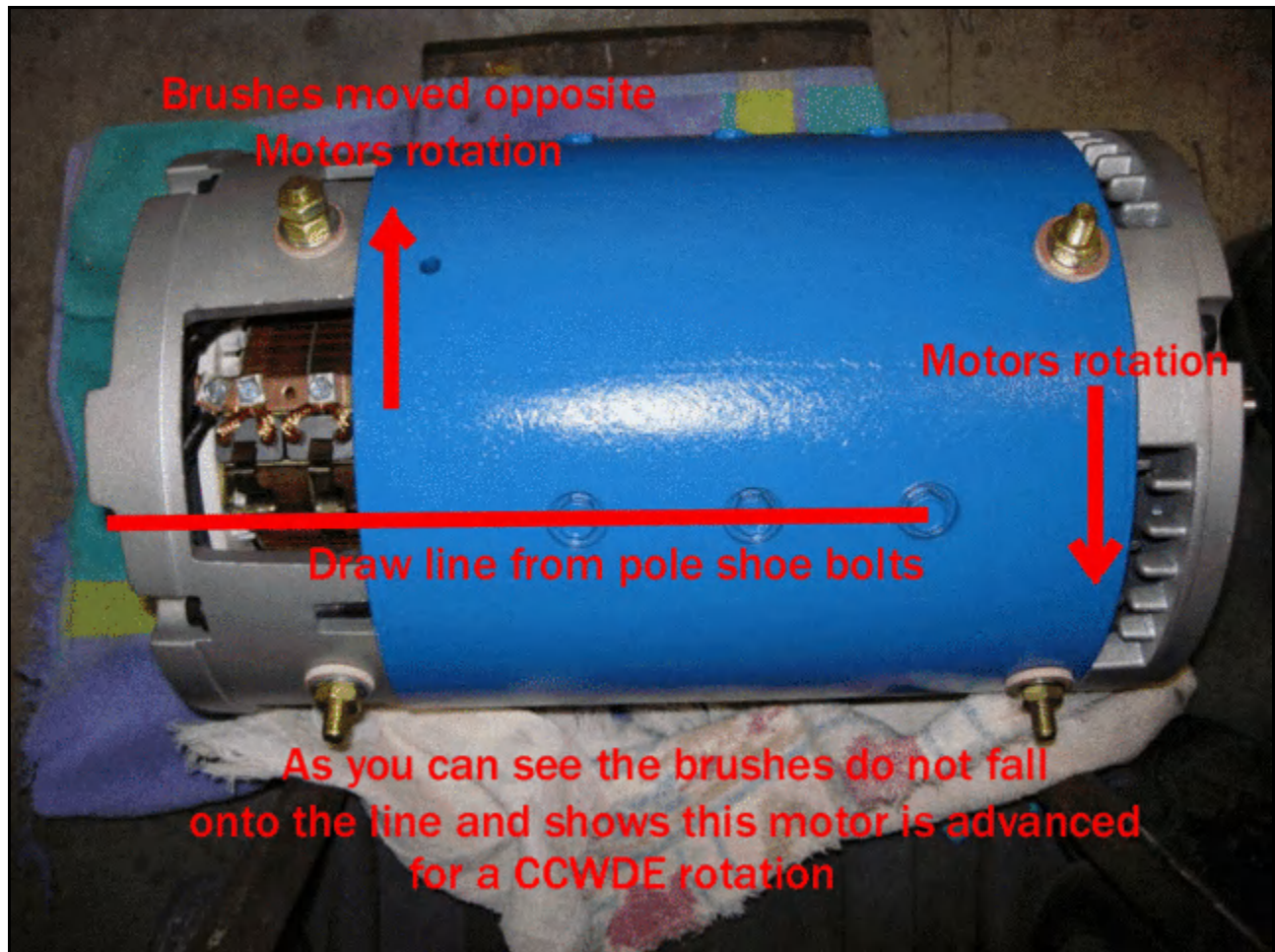

In the above picture you can see the red line running along the pole shoe bolts, and how the black brushes are above that line. This means the motor's brush timing is *advanced*, making the motor more efficient for **CCWDE** (Counter-Clockwise rotation from the viewpoint of the Drive End).

If this timing doesn't suit your desired rotation and you need the motor to turn in the clockwise direction, then you can change it by simply taking off the cover and undoing the bolts holding the brush position in place then reposition the brushes so they're below the pole shoe bolt line.

Advancing or retarding your motor timing will help your motor run more efficiently, run cooler, and reduce the risk of arcing at higher voltages and higher loads.

If you're looking at using regenerative braking, you'll want to ensure your motor timing is neutral (in the center position).

New DC Motor Options

Here are some examples of new motors suitable for use in average sized cars with the following voltages:

- **48 Volts:** Advanced DC #140-01-4005, 5.5" in diameter, suitable for 48 volt cars.
- **96 Volts:** Advanced DC K91-4003, 6.7" in diameter, suitable for 48 to 96 volt cars.
- **144 Volts:** Advanced DC #FB1-4001, 9" in diameter, suitable for 96 to 144 volt cars.

While I've listed the tried & tested "Advanced DC" brand, they're not exactly adventurous and there are many other electric motor manufacturers out there so don't be scared to shop around!

You'll find all kinds of motors that look the same but have different power ratings so write down the model number and ask people! Same goes for forklift motors, if you spot a bargain, write down any numbers on the motor, take a couple of photos and try to find out what it was used for, then ask people in EV clubs or at www.diyelectriccar.com if it's suitable for your particular conversion.

Finding a Cheap Electric Motor

As well as looking for second hand motors on ebay, there's another thing you can do to cut down your motor purchasing costs: use a second hand forklift motor instead!

Electric forklifts are pretty common things and like any device, they wear down and get outdated. Their electric motors however are often quite powerful and often outlast the life of the forklift.

Even though forklift motors aren't designed for performance, I've seen people put 144 volts quite happily into a 48 volt forklift motor.

The good thing about DC motors is that you can typically apply a much higher voltage than what they're rated to handle as long as you keep them cool.

In some motors you may have to advance or retard the timing (as mentioned above) in order to allow it to eliminate arcing at higher voltages.

If you think you've found a suitable motor, the things to look for are:

1: Weight & Size. The size & weight of a motor is a good example of how much power it will deliver. Look for a motor between 100 lbs (45 kg) and 150 lbs (68 kg) if possible. The heavier the car, the heavier the motor needed to push it around.

2: Condition. A dirty motor could be a hidden gem inside. Look for motor cores that are wine-colored with yellow banding. If it looks burnt inside then avoid it.

3: Armature & Commutator condition. Once again, look for scorched and burnt components inside the motor. Check to see the commutator isn't burnt and pitted. Look for commutators that have a large bar count. The higher the bar count, the higher the voltage the motor will take.

4: Shaft size & condition. Avoid a cracked shaft even if the rest of the motor is perfect. Also be aware of the shaft size & length as you'll need to find a way to make it work with a car gearbox.

If you're still uncertain, take as much info as you can about the motor such as model numbers, ratings and voltages and some photos, and post them up on an electric car forum such as www.diyelectriccar.com or www.hitorqueelectric.com

Selecting The Other Parts

With all the information so far, you should be decided on your choice of donor car and what voltage your EV will be. From here on you can start hunting for parts!

You will need to write a list of all the things you'll need for your conversion. You can copy this one as it includes all the main components of an EV. Some of these you can make yourself to cut costs, and others you can find second hand!

EV Parts List

- *Motor*
- *Controller*
- *Pot Box*
- *Vacuum Pump & Switch*
- *Voltmeter, Ammeter and Shunt*
- *Main Battery Cable*
- *Battery Connectors for the Cable*
- *Circuit Breaker*
- *Main Contactor*
- *Fuses & Holders*
- *Inertia (Crash) Cutoff Switch*
- *Battery Charger*
- *Deep Cycle Batteries*
- *Battery Box & Battery Mounts*
- *Motor Bracket/Mounts*
- *Gearbox to Motor Adapter Plate*

There may be extra things that aren't listed above that your EV might need such as extraction fans for battery boxes located in the trunk (to remove the hydrogen gas that is generated while charging) and relays for heaters and such.

With your list in hand it's time to go shopping!

Remember that the price of some parts (controller, motor, circuit breaker etc) will vary depending on your voltage. Make sure the motor or controller you're looking at is suitable for your selected voltage. All EV parts dealers will be able to tell you this and it's typically listed right below the product you're looking at.

Where To Buy New Parts:

If you're looking to buy *new* parts for your EV or simply compare pricing, here are some EV parts dealers to consider (which will ship to international locations):

www.evamerica.com based in NH, USA

www.evparts.com based in WA, USA

www.electroauto.com based in CA, USA

www.cloudelectric.com based in GA, USA

www.kta-ev.com based in CA, USA

www.electricvehiclesusa.com based in SC, USA

www.electricmotorsport.com based in CA, USA

www.grassrootsev.com based in NV, USA and FL, USA

www.canev.com based in BC, Canada

www.zeva.com.au based in WA, Australia

www.evpower.com.au based in WA, Australia

Where To Buy Second Hand Parts:

If you're looking to find second-hand parts to cut costs then this is where the Internet will be your new best friend! Have a look for these sites and forums:

www.evtradinpost.com

www.diyelectriccar.com/forums/forumdisplay.php/classifieds-4.html

www.visforvoltage.org

www.ebay.com

Also, be sure to check out if there's an Electric Vehicle club or organization in your area. You can find many clubs listed here:

<http://pages.prodigy.net/noela/linksto.htm>

<http://www.diyelectriccar.com/forums/forumdisplay.php/ev-clubs-23.html>

or even by searching with www.google.com.

Chances are there's an EV club in your country or state!



Selecting your parts can look like a daunting task but it doesn't have to be. To familiarize yourself on what voltage works for what sized car, or what parts others have used, or even just to find another EV owner in your area, go to www.evalbum.com There are thousands of electric vehicles with their specifications listed. This site can also help with inspiration. Click there any time you need a morale boost to help complete your project!

Also consider joining up with an international EV discussion group such as www.diyelectriccar.com as the people there are often very supportive and will help you track down bargains and substitute products to save money.

Chapter #4

Dismantling the Donor Car

Chances are you'll have dragged home a sick or dying car by now, often to the horror of your partner or spouse. After you've finished convincing him or her of the benefits of an EV, and after you've finished sitting in the driver's seat pretending it's an EV then **the work can finally begin!** ☺

During the evenings of the dismantling process (which can take minutes or weeks depending on your enthusiasm) you should be busy hunting for your selected EV parts from auction sites and websites such as those mentioned in Chapter #2. This way, by the time you've finished this chapter, some EV components will start arriving!

Tools You'll Require

For the dismantling stage you're going to need some tools such as an engine hoist, a set of spanners and a socket set.



Considering you'll only be using the hoist once, try to **borrow or hire one for the day**. As for the spanners and sockets you'll find yourself using them a fair amount through the conversion so I recommend buying your own and buying a quality brand.

You don't have to go to a specialist shop, any auto parts store should do – just don't buy the cheapest tools known to man because they *will* break - I promise!

There's nothing quite as annoying as having two bolts to go and your spanner snaps or socket changes shape under pressure. I've learnt the hard way so you don't have to – spend an extra few dollars on quality tools. It's worth it as they'll last your lifetime and be useful for future conversions too.

Clean Out Your Garage In Preparation

I'm sure you're keen, but before you start dismantling the donor car, make some space! Move or throw away some of your junk (believe me, every house has junk!) and make room for the many things that will be coming out of the donor car.

Some items from the car will be rubbish destined for the scrap heap, and others will be worth something to someone out there.

Have 2 empty sections in your garage:

- one for keeps
- one for trash.



Also be ready with a bag of disposable paper cups and a marker pen – this is vital for all the many bolts and screws that will come out of the car and eventually need to go back in – sometimes in order!

Try and find a **shelf space** where these cups won't be knocked over like bowling pins when you decide to triumphantly throw discarded engine parts across the garage without looking. I've been there and done that! It's often followed by a few seconds of cursing, then 20 minutes of crawling around on your hands and knees trying to put the bolts back into their respective cups!

Take Photos

Before you start removing anything, be sure to take photos – lots and lots of photos. Take photos of every corner of the engine bay and every hose and wire from every angle. This will come in very handy in the future when you can't remember where a particular hose went or what that blue wire was connected to etc. Even take plenty video footage if you're able to. Not only will the photos and video footage be very useful, but you'll be able to **show strangers and friends the before and after shots!**

Label All Wiring

On top of photos and video, be ready with insulation tape (white if possible) and your trusty marker pen. This way you'll be able to wrap a piece of tape around a wire and label it. If you do this before you dismantle the engine bay you'll be very glad you did. When the new parts go in you'll be able to decide if you want to reuse a particular wire (eg. the wire that feeds the RPM or temperature gauge) or get rid of it completely (eg. the wire that feeds the engine oil light) or find another use for it.

Draining The Fluids

Now that you've been busy with your camera and marker pen "**it's time to get dirty**"! Before you touch the car with any tool make sure you've run the gas tank as low as possible – it'll make life easier later!

Start the engine removal process by draining the fluid from your car's radiator. If the engine still runs, do this when the engine has cooled down as there's a lot of pressure in car coolant systems when hot.

There should be a drain plug at the bottom of the radiator as well as the cap at the top. Open both and collect the coolant into a bucket. If you can't find the drain plug or if it's stuck, loosen the lower rubber coolant tube. Don't tip the waste coolant into a drain or let pets drink it as it's quite toxic. Put it into a bottle and ask your local garage or gas station if they can accept it.

If you're planning on dismantling your engine, now would be a convenient time to drain it of it's engine oil. Same goes with the waste oil - don't throw it in your trash. Most garages should accept waste engine oil. (*Notice the lack of a radiator, radiator hoses and a carburetor*)





If you're keeping your engine intact, then leave the oil in there. No oil should spill out during removal under normal circumstances.

Separating The Engine From The Gearbox

Depending on the design of the car, when removing the engine be sure to you'll need to separate it from it's gearbox. This is the case for almost all front-wheel drive cars. Some rear-wheel drive cars can keep the gearbox attached to the engine and the two can be removed together.

Either way, both are going to be removed eventually so that you can measure the gearbox for it's electric motor adapter plate.

Make sure you have a hoist of some sort for this. Start by disconnecting all the obvious things such as the exhaust manifold and the air filter and hoses, then get stuck into the wiring. If you're planning on keeping the engine intact remember to think ahead and keep important looking things attached or at least labeled.

Once you've got the weight of the engine supported on the hoist, start disconnecting the main engine mounts. Start from the bottom up so that no one has to go under the engine when it's dangling precariously on the hoist!

Take photos of this process just in case they come in handy in the future. After you've hoisted the engine out and set it aside you'll have better access to the engine bay to remove other things such as the fuel lines and exhaust.

I'd recommend pushing the car outside and giving the engine bay a good scrub to remove the oil and sludge left there from its former resident.

Removing The Gas Tank

When removing the gas tank **be careful**. The car may be dead but the gas in there is still very much alive and it's not known for its compassion and sense of humor when poked with a flame or spark!

Some tanks have a threaded drain plug at the bottom which is helpful. Unscrew this slowly and carefully, not just because it's metal and could spark if bashed about, but also because you want to be ready with a bucket when it falls out with 2 gallons of gas behind it! If your tank doesn't have a screw plug then you'll have to drain it once it's out.

Either way, de-crimp the hose fittings from the side/back as well as the front of the tank and unscrew the tank from the underside of the car. This is one of the least fun jobs because of all the dirt and build-up under most cars. A pair of safety glasses or swimming goggles is recommended at this stage to keep the dirt out of your eyes.

The fuel that comes out of the tank is obviously useful for running your lawn mower or pouring into your other car, but I kept mine in a bottle for cleaning bolts and removing grease from the engine bay and gearbox. You may want to do this too.

Sell Those Old Parts

You've probably got quite a pile of old parts in the corner of your garage by now. Some will be useful to resell and recover some costs. Things like the radiator and it's fan, the alternator, the carburettor (if it has one), the catalytic converter, the engine (if it runs) can all be listed on www.ebay.com or your local paper.



Some EV converters can get several hundred dollars back by placing a 3 dollar advertisement or ebay listing. You've got nothing to lose and a few dollars to gain so give it a shot! You may want to wipe the engine first with the waste fuel from the tank or an automotive de-greaser from an auto parts store.

Removing The Gearbox

If you haven't done it already, remove the gearbox from the car. If it's a front-wheel drive system it can be a little tricky to get the two drive-shafts (from each side of the gearbox to the each front wheel) out of each side of the gearbox.



(Gearbox removed with clutch disc visible)

You'll find either an accomplice or a hoist will help here as you wiggle the gearbox frantically in every direction. When the shafts finally pop out, be ready with plenty of newspaper and some rags as quite often the gearbox oil will spill out through the now open drive-shaft holes all over your floor. This type of oil is hard to remove and often smells quite bad.

By now your donor car should be **empty, clean** and **ready to become electric powered!** All that's left to do to sell any useful engine parts you've removed.

Onwards to Chapter #5!

Chapter #5

Planning The Location Of Components

If you're using a sedan or hatchback, remove the carpet and plastic paneling from the trunk, then measure the space as best you can. Take photos too if you can.

If you're converting a *ute* or *pickup truck*, lift or remove the back tray to see the chassis underneath, and measure the available spaces in there too.

Together with photos and measurements you'll be able to make decisions on battery sizes and component locations without leaving your computer chair as running back and forth between the PC and the garage gets a little boring after a while.

By now you should have decided which batteries you're going to use for your conversion. I recommend making a cardboard mock-up from the battery dimensions. Try to make it as accurate as possible and see how it fits into your donor car in the real world. You'll probably be surprised how big the battery is in real life. This is good, it'll give you an idea of where they can go and how they fit.

As I used a small sedan in my conversion, I was forced to split the battery pack into 2 sections. I had six 12 volt batteries in a box in the trunk, and another six 12 volt batteries in the engine bay like this:

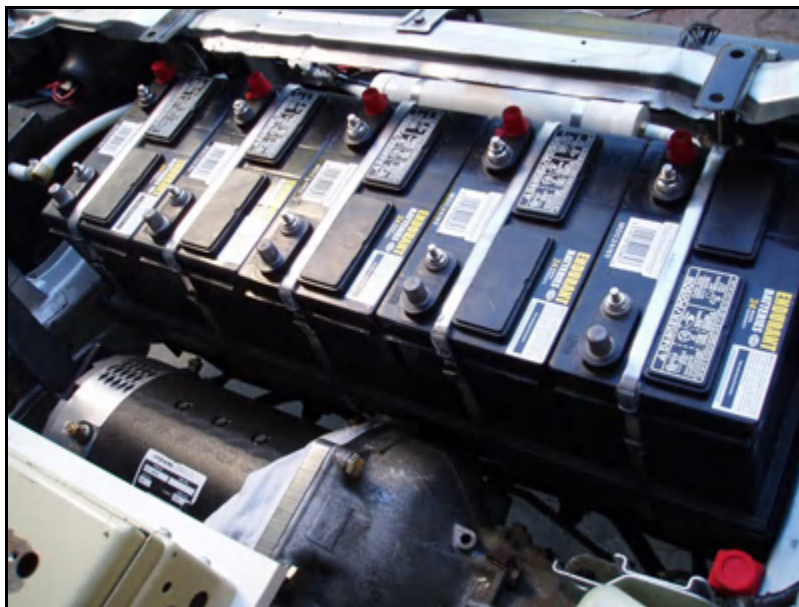

(Batteries installed in the front)

and



(Batteries installed in the back)

This had the benefit of keeping the car's weight quite even between the front and rear tires. You may want to do something similar if you're using a sedan or hatchback. Alternatively you could split the battery pack up into even more sections by placing 2 or 4r batteries under the back seat.

Make sure they'll **fit safely** before you do this though. Take into consideration the clearance between the seat and the battery terminals, as well as the bottom of the batteries to ensure they're not removed at the first speed bump!

If you're using a pickup truck or utility, you can often fit the entire battery pack into the rear tray itself. This can save a lot of time and effort but it can raise the center of gravity slightly, making the car feel more 'wobbly' going around corners.

If you have the time and skill, try to include the battery pack into the lower frame of the vehicle, hidden below the actual tray. This will keep your center of gravity lower, giving you a bit more stability around corners.

As every car is different and every conversion has different components, it will **require your own cunning and creativity** to fit your exact battery size & type into your chosen donor car. If you've ever played with Lego or if you've ever put a jigsaw puzzle together you'll have a pretty good idea of what's involved. It's like a jigsaw puzzle but bigger.

If you do find yourself getting stuck, try asking your local mechanic or another EV converter in your area as he or she will almost certainly be able to offer solutions for your battery location woes.



Keep in mind that approximately every 2 months you're going to have to top up the water in your batteries (unless you're using the more expensive Sealed Lead Acid batteries), so ensure **the tops of your batteries are easily accessible without having to dismantle the car!**

Your controller needs a dry place to live inside your electric car. I recommend placing the controller on the car's firewall or on a shelf, away from the front grille in case of heavy rain like this:



See how the controller (rear, right) is sitting on a heat sink (in this case a simple sheet of aluminum)? This helps to remove the heat generated while driving, and if you're driving a lot your controller will get quite hot.

Many converters will integrate a fan with under the controller's heat sink to help remove the heat. This is **strongly recommended if you live in a warm climate** or you may see your controller turning into an impressive fireball under load.

You're also going to need a home for the main components of your electric car such as the circuit breaker, fuses and any relays your system might need. In my case I used the **cream colored box** on the left of the controller in the photo above. You'll notice all the cabling is concealed underneath the board. It's easy to do and it makes for a very tidy conversion. Too often I've seen beautiful conversions made messy by a sea of wires under the hood.



If you're a stickler for tidiness (like me for example) you can try this **experiment** to hunt down offending mess you weren't aware of:

- *Open your hood, then look away at something else and close your eyes.*
- *Turn back to the engine bay and open your eyes.*
- *Note down the first thing that takes your interest or looks messy – that's the first thing someone else will notice too!*

Your neighbors will think you've lost your mind if they see you performing this technique, but trust me - it works!

You'll also need to decide where your cable will run and how many lengths you'll need. Have a good look under the car for pockets to run your cables in such as the **route** that the exhaust pipe or **fuel lines** used. You can try using a rope or a long tape measure to do this.

Lastly, you need to take the measurements of your choice of electric motor and see how they'll fit into your engine bay. Measure from the open end (aka bell end) of the gearbox housing to the side of the car and make sure there's enough space for the motor and its tail shaft (if it has one).

Make sure there's enough room left over for a motor mount to fit in too (covered in the next chapter). If possibly, you should have at least 3 or 4 inches available between the end of the motor and the side of the car's engine bay just in case you need to run cables or vacuum lines - or maybe get a rag in there to clean your pride and joy!

Chapter #6

Installing the Motor

Time to get that motor installed onto your gearbox! I consider this the most difficult part of the conversion as it requires a bit of precision to couple the two together. Once this part's done the rest will fall into place.

You have 3 options with obtaining a gearbox coupler:

- 1. Build it yourself*
- 2. Outsource the job to a local garage or engineer*
- 3. Obtain an adapter plate kit from an EV supplier (if they have your car's model in their catalog).*

For the purposes of simplicity and cost I recommend using the popular "**clutchless adapter & coupler method**" It's lighter, simpler and easier than keeping the clutch though it does require learning how to change gear without a clutch.

It's not difficult, though changing gear without the clutch in an electric car takes an extra 2 or 3 seconds to do. The benefit of an EV however is that you'll actually change gear very rarely. In fact most days I've done all my driving in 2nd gear ranging from a complete standstill to 45mph (72km/h) never once touching the gear lever!

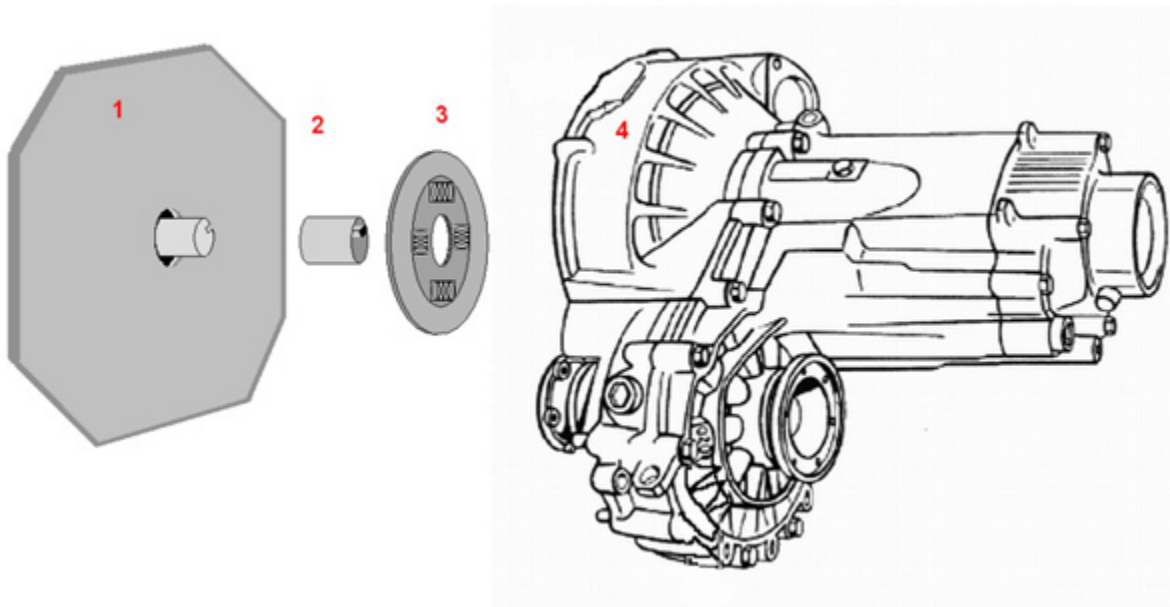

The basic assembly of a gearbox to motor adapter looks like this:

- 1:** The adapter plate, which both the motor and the gearbox bolt to from each side.
- 2:** The keyed socket which fits the motor shaft, which needs to be precision-welded to:
- 3:** The car's old clutch disc.
- 4:** The car's gearbox.



I can't stress enough just how important it is to **have this assembly perfectly straight**. Even just 1 millimeter of imbalance will create a noticeable vibration while driving, and the coupler will eventually break - most likely when you're showing off your motor's torque at a red light!

Unless you have some serious tools in your garage (such as a lathe) I'd recommend giving this particular task out to a friend or colleague with machining skills, or even finding an engineer to fabricate a coupler for you. That way you know it won't break – or if it does, you have someone to blame other than yourself!

If you have an adventurous streak and you're keen to give it a go, then I'll explain what's involved. Firstly, let's look at a typical motor shaft:

Typical motor shaft



and

Typical gearbox shaft



Some gearboxes have a **pilot shaft on the end**, making the entire shaft very long such as this one:



With long gearbox shafts you have 2 options: you can either cut the pilot shaft off (recommended), or you can use a spacer plate – often a thick circle of metal with the center removed. This would go between the gearbox and motor to move the 2 further apart, so the long gearbox shaft can remain unmodified. This is a little more complicated and often unnecessary if your pilot shaft has no threading or spline and serves no purpose in its new role. Here's a picture of the same gearbox with the pilot shaft simply cut off with an angle grinder:



The gearbox adapter method I recommend using is the *Lovejoy coupler*, which is a ready-made coupler designed for keyed shafts (which most DC motors have) and it simply slides onto your electric motor shaft. All that's needed is to enlarge the hole in the other end for your clutch disc spline to insert into.

Here's a picture of a *Lovejoy coupler* with the car's clutch spline removed from the center of the clutch disc, reduced in size and smoothed out to fit, ready to be popped straight in:



The above spline (removed from the center of the clutch disc) has been milled down in size, and the front of the *Lovejoy coupler* has been drilled out larger.

Once the hole in the front of your *Lovejoy coupler* is enlarged, the clutch spline should fit snugly in so it can be welded in place externally. This weld must be able to move the weight of the car under load or acceleration so make sure it's tough.

If you're not comfortable with machining out your clutch spline and/or welding it into a *Lovejoy coupler*, take the coupler and *Lovejoy connector* to an engineer, let them do that part and you could simply make the adapter plate itself.

To make the adapter plate you'll need to work out exactly how thick it should be, so that the coupler will fit in between the shafts perfectly without any lateral movement.

Every gearbox is different, so you'll have to figure out your "critical distance" between the front of your electric motor and the front of the gearbox's bell housing, and then the distances between the two shafts in order to make your coupler. Some people even cut out a portion of their gearbox's bell housings for a better view.

This coupling can take a few attempts to get it just right so be patient. This is a crucial part for your EV and shouldn't be rushed!

Here's a picture of the above coupler in place:

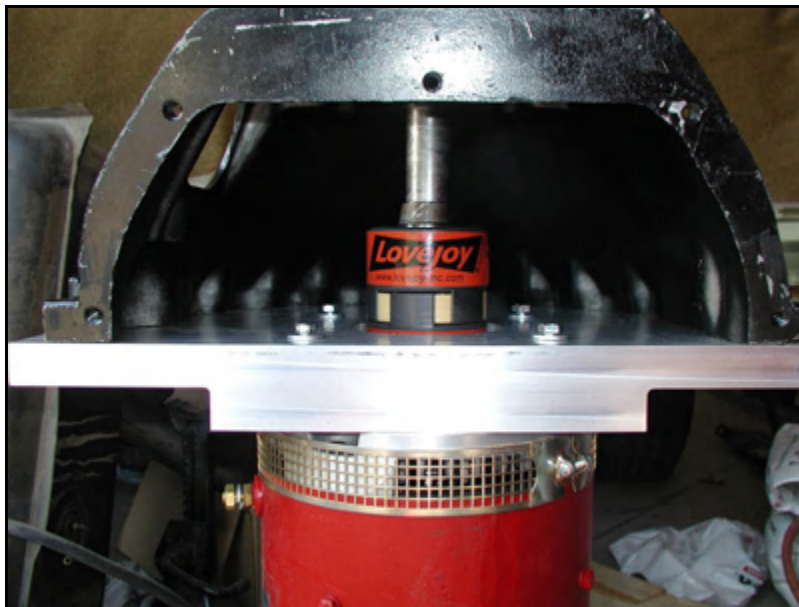

Notice in this conversion the shape of the adapter plate where the motor attaches? If you're not up to machining a piece of metal into the same shape you could simply double up the width of the plate with 2 metal sheets on top of each other.

Once you have your motor coupler installed, your motor bolted to your adapter plate, and your adapter plate bolted to the gearbox, give them a test spin by applying a 12 volt battery to the terminals of your motor. It should spin without any noticeable vibration. If there is a noticeable vibration then take it apart and fine-tune it while you still can. If you don't, it'll be the first thing people notice when you take them for a spin!



Important note about motor rotation: Most large DC motors are set up to spin *counter-clockwise* (if you're looking down the motor's main shaft), while most car gearboxes spin in a *clockwise* direction (if you're looking down the gearbox shaft). This suits most conversions just great as the two can join straight together.

Some gearboxes however spin in a *counter-clockwise* direction, which means your car would end up having 4 or 5 reverse gears and one forward gear. This is often fixable by changing the brush timing inside the motor and reversing the polarity of the input power.

As a general rule of thumb the brushes are considered "**neutral**" when they line up in-line with the motor's *field coil pole shoe bolts* on the sides of the motor.

To advance the motor's timing you must move the brushes opposite the motor's rotation by a number of degrees relative to your voltage. *Warp* and *Advance* motors come with both direction advancement holes already, and if you're buying a new motor, tell your supplier which model of car you have so they can adjust the motor rotation direction for you.

If you're using a second hand motor you can check the timing easily by taking off the motor's cover:

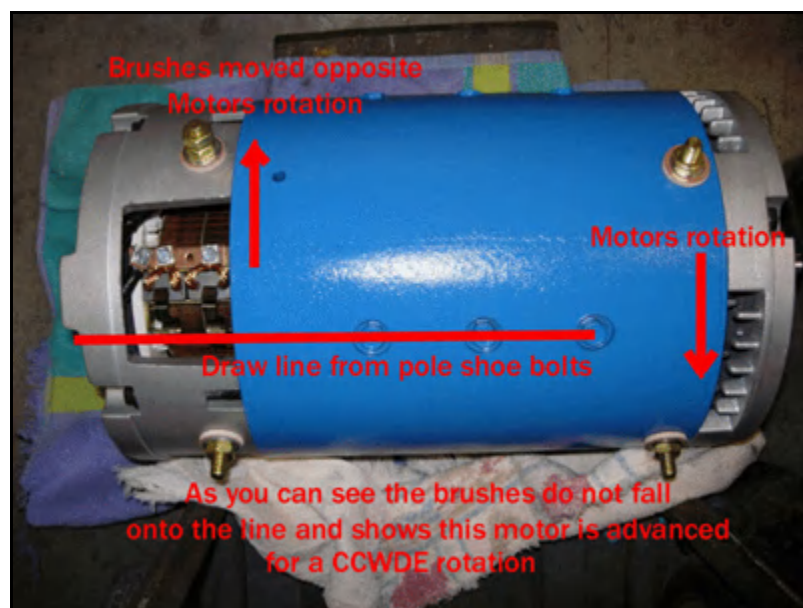

The above motor is set for *Counter-Clockwise* rotation which is the most common rotation used. For some small cars (Hondas) you'd need to rotate the commutator plate till the brushes fell on the *other* side of the line. Many motors have ready-made bolts for this exact purpose.

If you've taken the cover off but you're still in doubt you may want to check with motor guru **Jim Husted of Hi-Torque Electric** or try doing a search of his site for instructions: <http://www.hitorqueelectric.com/contact/>

Just remember, a picture is worth a thousand words so take plenty. It makes motor identifying so much easier.

The next step is to install the motor into your car's engine bay. This part is different for every car. Like gearbox adapters, electric motor mounts are often available for your specific car, saving you the hassle of making your own. You could try contacting some of the EV parts dealers if you're not in the mood for a bit of welding!

Here's a picture of my motor installed into its new home:



In my EV I removed the rubber mounts completely in order to simplify the installation. This isn't a problem for the motor as the purpose of the rubber mounts is to reduce the engine's vibration from running through the body of the car. Electric motors have no vibration so with the mounts removed you won't feel any difference, though you may notice more gearbox noise traveling through the car. Keeping the rubber in your motor mounts is completely optional.

The next car I convert will have the rubber mounts removed again for simplicity but there are noise reduction benefits to keeping them installed.

As well as the motor being mounted to the gearbox and the car's frame, you'll need *at least* one other support holding the motor to the frame of the car, and there must be one lateral mount installed. Without a lateral mount (to prevent the motor twisting under load) your mounts will weaken and the coupler could snap. Everything must be kept firmly in its place.

**Here's an example of the lateral mount
I used in my own conversion:**



You can see it running from the motor & gearbox adapter down to the frame where the previous engine mount was located. This lateral mount meant that the motor didn't twist – even when I was showing off with a heavy right foot!
If you want to keep the rubber mounts, you can often create new motor mounts

from your engine's existing mounts: Start by grinding any useless arms or extremities off the existing mount, then smooth down and weld on your own arm, reaching to your motor with bolt holes where necessary.

If you want to ditch the rubber mounts then you can often make your own mounts from hollow metal tube, angle-iron, and an hour with a welder.

Remember to always **cover your motor when welding near it**. Use an old towel or rag and tape it up, making sure no sparks or bits of metal end up inside it.

By now you'll have a basic idea of what's required to join your motor to your gearbox and where to install your own mounts if you're making your own. Just remember though, this is one area where you don't want to cut corners. If you make it strong, you can't go wrong! And to think I never took up poetry in high school...

On to chapter #7!

Chapter #7

Installing the Controller

Depending on what make and model of controller you'll need to read the included instructions thoroughly before wiring it up, so in this chapter we're going to focus on the physical installation.

The **2 most important things** to take into consideration when positioning your controller are dryness and airflow.

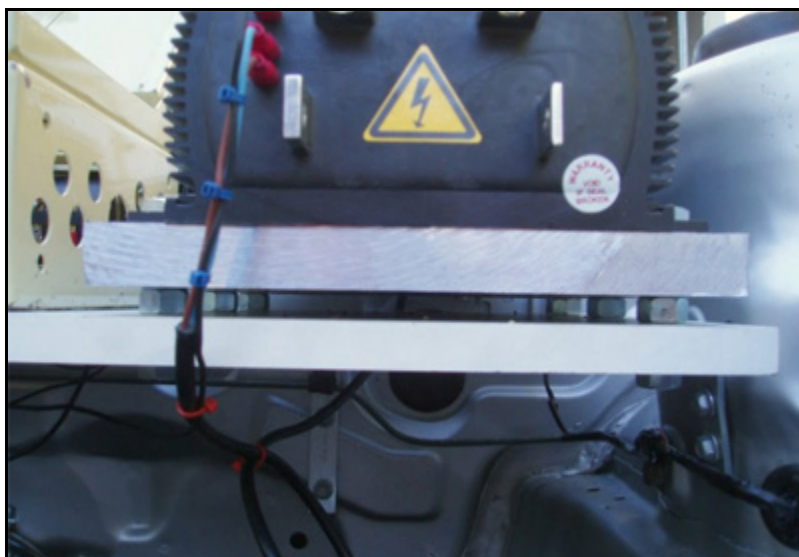

As you can see in the photo above, the **controller** in my own conversion **is sitting on an aluminum plate** which is raised off the support board to allow air to flow underneath the controller.

The purpose of the aluminum plate is to dissipate heat from the base of the controller. Aluminum is good for this purpose, though in my case I was only driving short distances in moderately cool weather most of the time.

I found that the controller never got hot to the touch in my case but in conversions in hot climates or with heavy load driving the controller can often become too hot to touch – which isn't good for the components inside and will shorten the life of often the most expensive component in an EV.

To combat this you have a couple of options. You can buy ready-made heatsink kits from many EV parts suppliers with fans included for approximately \$200 to \$300 US – or you can have a go yourself!

To create and install a heatsink under the controller you have 2 options:

- *installing a basic sheet of aluminum to dissipate heat, or*
- *installing a finned heatsink with fans underneath it forcing air under the controller.*



In the picture above, the heatsink assembly is being fitted onto the controller and its mounting board. (Note: the controller is upside down).

The mounting board in this conversion is a sheet of polypropylene (an excellent insulator) with a large hole cut into it so the controller can maintain contact with the heatsink and its 2 fans.



This is the same heatsink design disassembled. The controller sits on top of the assembly, under that is a thin aluminum sheet with heat transferring gel in between, then the heatsink running through the polypropylene mounting board, then another sheet with 2 small DC fans operating. A great design and simple too.

You'll have to decide which method is best for you. If you're uncertain, try using a simple sheet of aluminum raised off the board and monitor it closely every time you drive. If it gets worryingly hot then look at forcing air under it.

Some converters install temperature gauges on the heatsink next to the controller to monitor its temperature. You may consider doing the same. If so, keep an eye out for temperature gauges that you can monitor from a cheap digital multimeter. This can save a fair amount of time and money on a professional setup if you don't mind a multimeter sitting on the dashboard.

The next consideration with mounting your controller is where exactly to put it. Remember that this is a fairly sensitive piece of equipment and they dislike water.

Controllers such as the Curtis brand are sealed, but moisture is a creative substance and will often find a way in somehow!



Just like the above picture, I recommend mounting the controller on an insulated board as far back from the front grille as possible.



Don't consider mounting the controller inside the car. While doing so may offer relief for cold hands in winter, running your high voltage cables inside the car is a not recommended and many inspectors will not approve a car with the high voltage lines in the passenger compartment.

If you're planning on mounting your controller on its side or out of the way, while it's not a problem with most controllers (check your controller's manual), keep in mind the complications involved if you have a problem with your controller or plan on upgrading at some stage.

Removing parts can be a real pain if there are things installed on top. Sometimes this just isn't an option in tight engine bays full of batteries but do keep component breakdowns in mind if you can – as rare as they are.

Chapter #8

Installing The Components

Good news! All the hard work and brainstorming is over and from here on the work gets fun! By now you should have a box of components from EV parts suppliers, junkyards, forklift parts suppliers and ebay. **Time to find homes for them all!**

As mentioned in the previous chapter, I recommend installing a control shelf for all your components to sit on, and maybe even a control box to keep things tidy. One of the big benefits of a control shelf is that everything is kept in one location, making it easier to find and fix faults as well as keeping wiring to a minimum – often hidden underneath the board. Don't underestimate the impact that tidy wiring will have on first impressions of your EV's "engine" bay. People will see the lack of wire everywhere and say "where is everything?". It's very satisfying!

Connecting The Potbox

The first step is to connect your potbox or potentiometer box to your accelerator cable. Find somewhere convenient but out of the way of the other components.

Remember to keep a gentle bend on the accelerator cable as it comes through the car's firewall. Bending it too tightly will increase its resistance and you could find the accelerator sticks on. While flying through a stop sign at 40 mph is often a good conversation starter, I don't recommend it.

I know it sounds obvious, but make sure your *potbox* is the right way up. If your car is right-hand-drive then you may have to mount it upside down so that the arm moves the correct way. The arm should pull towards the driver when the accelerator is pressed down.

As well as the long coiled cable coming out of the *potbox*, you'll notice there are 3 pins on the underside. These are for the High Pedal Lockout – a simple system to stop any damage to your motor or people in the event of turning the key while your foot is on the gas and while your car is in gear.

Here's a simple circuit diagram of how a High Pedal Lockout relay works:

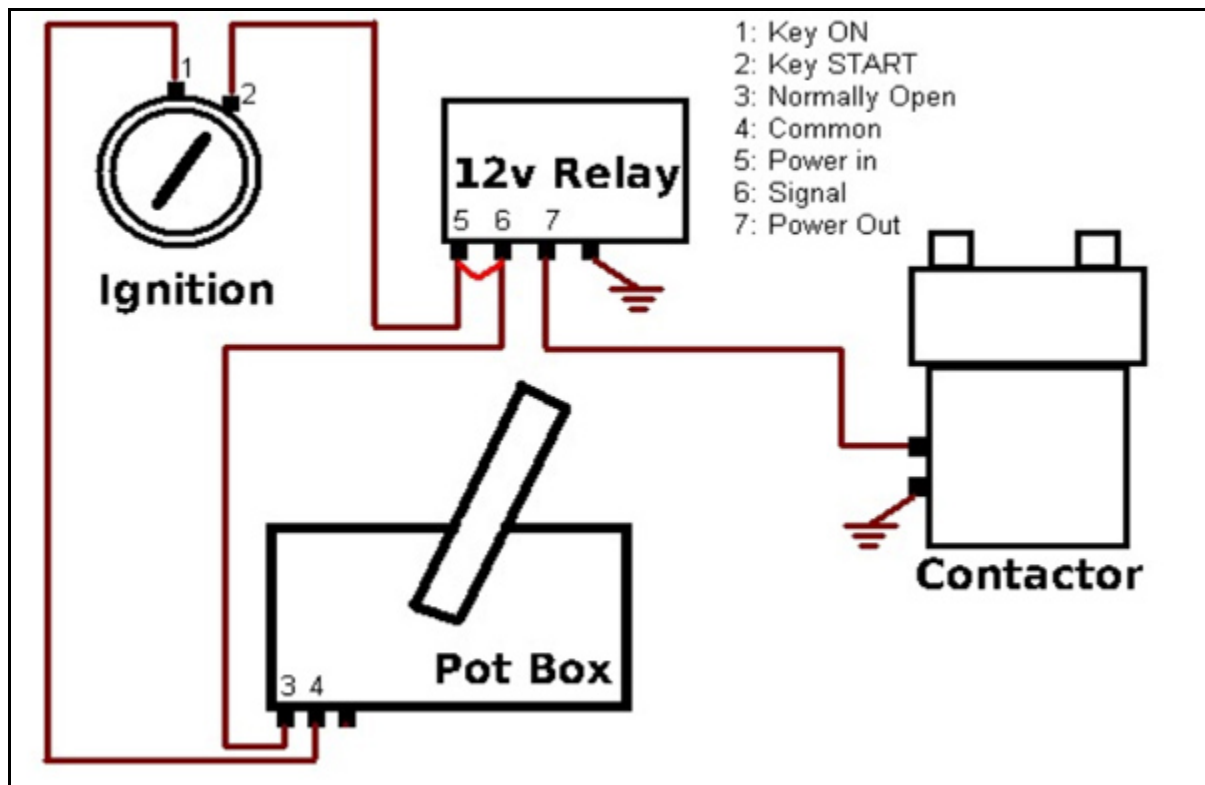

Using the pins on the underside of the pot box and a 12v automotive relay you're able to protect your car from starting while your foot's pressing down on the gas – a habit some gas car drivers have for starting older cars on cold mornings.

With the relay in place, the contactor won't click until your foot's off the accelerator. Once your foot is off, you can turn the key and it will click on. Notice the wire bridge between points 5 and 6 – this forces the contactor to stay on once you've "started" the car, until you turn off the key. *Easy!*

As I've mentioned before, if you want a tidy EV then I recommend installing your components into a box of some sort with a lid. Not only does it hide all the wiring but it keeps the dust and moisture off your components too.

Place this box onto a board, preferably some sort of *poly-resin* or *hard wood*. I don't recommend placing your high voltage components on a metal shelf as there's always the risk of shorting things out by mistake.

Meter Installation

You'll need to find a place to hide your *Voltmeter* and *Ammeter* in your car. I've seen all manner of curious hiding locations for these important gauges – just put them wherever you want.

This is another key component that people will look at and ask about so I recommend placing them somewhere tidy and hiding your wiring behind the dashboard wherever possible.

You'll notice your *Ammeter* has a “shunt” with it. Or at least it should – you'll need one of these! Mounting the shunt inside the component box is a good idea to keep it out of the way. As shown in the Introduction, the shunt is a piece of passive equipment that takes the high amperage load flying through the circuit and allows a tiny signal to flow to your ammeter, your ammeter translates and reads this signal out as the actual amperage.

Fuse Installation

You should have at least 2 high voltage fuses in your EV (as seen in the introduction). Depending on your battery configuration **you could have one at the front and one at the back.**

These fuses are there in the event of a short circuit that could cause batteries to explode. In the event of an emergency your circuit breaker should trip before the fuses blow. Or at least we hope – high voltage fuses aren't cheap! If you can, mount one of these fuses inside your connection box to keep things tidy.

Circuit Breaker Installation

If space permits, I recommend mounting your circuit breaker inside your connection box also – don't mount it inside, even if it's convenient as in many countries this isn't allowed. It must be able to be tripped from the driver's seat though, so most EV converters will install a pull-cable running from the dashboard to the circuit breaker handle. I used an old choke cable and choke knob from an old car and drilled a small hole in the circuit breaker's handle to run it through and secure it.

Inertia Switch Connection & Installation

Next on the installation list is your crash switch or inertia switch (as seen in the introduction). This should be mounted to the chassis of the car, near the front but not on the bumper. Fix it securely to a metal part of the frame close to the front bumper so that in the event of a crash it will trip and break the contactor. Run the "ignition on" cable that you tapped into the ignition through your inertia switch so it will kill all the 12v electrics (and subsequently the high voltage electrics) if tripped. Some converters have found resettable inertia switches in auto wreckers yards. Talk to your local wrecker to see if he has any 2nd hand ones in stock as new ones are around \$80 US each.

The Accessories Battery & DC to DC Converter

To run your headlights, turn signals, wipers etc you'll need to keep a 12 volt "Accessories" battery in your car. Of course if this battery has no method of being charged it'll go flat very quickly.

You have 2 options to keep it charged up:

- **Option one** is a cheap but slightly inconvenient method. When you plug your car in to recharge, you could also connect a separate 12 volt battery charger to the car's accessories battery. I tried this for several months on my own EV and I found it took an extra minute after each drive and it became quite annoying quite quickly. One way around this is to put a small plug on the end of the charging leads, and a small socket on your bumper or inside the filler cap connected straight to the car's accessories battery. So when you pop your filler cap to plug in your car, you can also plug your 12 volt charger into it's own plug too.

- **Option two** costs a little more but is much easier and requires less of that *how much does the battery have left* anxiety and worry. Option two is called a “DC to DC Converter” which takes whatever your car's voltage may be (eg. 96 volts DC) and converts it into 12 volts DC to keep your accessories battery all charged up while you drive.

Building Your Own DC To DC Converter



This is an example of a computer graphics power supply which I modified to turn it into a DC to DC converter. Buying a "proper" DC to DC converter from some EV part suppliers with the same 30 Amp output would have cost me \$199 US + shipping.

But by using the above *Thermaltake 450 Watt Power Express* at \$61 US (+ shipping from Amazon.com) I kept \$140 US in my pocket! You can do the exact same thing using the easy instructions below, or if it seems a little too much for you then consider buying a factory made DC-DC converter from almost any EV parts dealer. If you'd like to try modifying a computer PSU (power supply unit) yourself then follow me!

Minor circuit modifications are required for this model of PSU because by design it puts out 12.05 volts, however to keep a car battery charged up, the output voltage needs to be a little higher, such as **13 volts**.

I found I could force it up to a stable 13.7 volts before it's over-voltage protection kicks and the unit powers itself off, though I also found at that voltage too much load will switch it off quite easily and the last thing you want is your power supply turning off when you have your lights, wipers & heater going flat out!

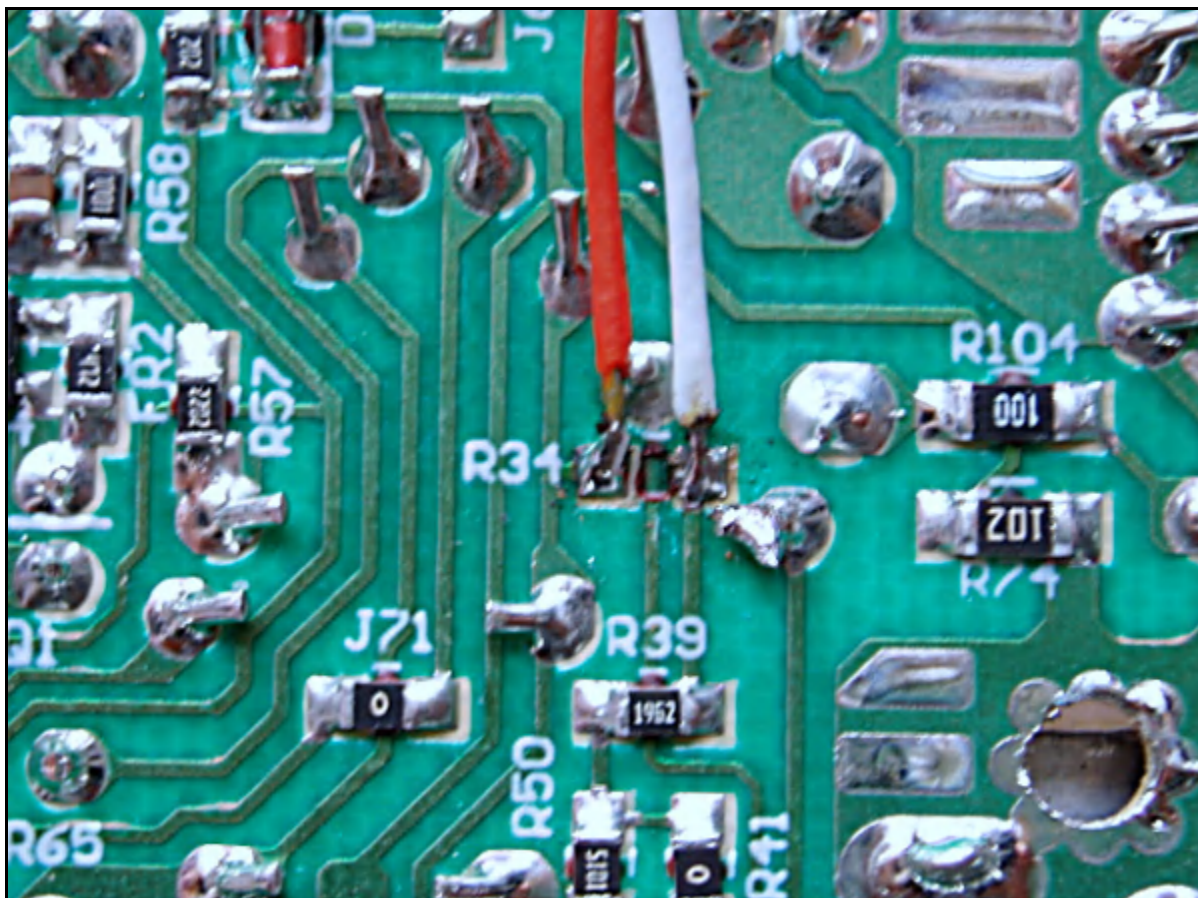

After installing a \$2 0-5k ohm potentiometer I found around **12.7 volts** output gave me super-stability even with every electric option in the car running full blast. You'll rarely have every single electric option in the car running at once so you could try taking the risk and putting it up near **13.2 or 13.5 volts** if it will take it without switching off. Learning is part of the fun in this case and once it's fired up you can adjust the voltage with the potentiometer until it's perfect for your car. If the unit switches off, wait 30 seconds with the input power disconnected and try it again.

It'll power up again after it's had a moment to breathe.

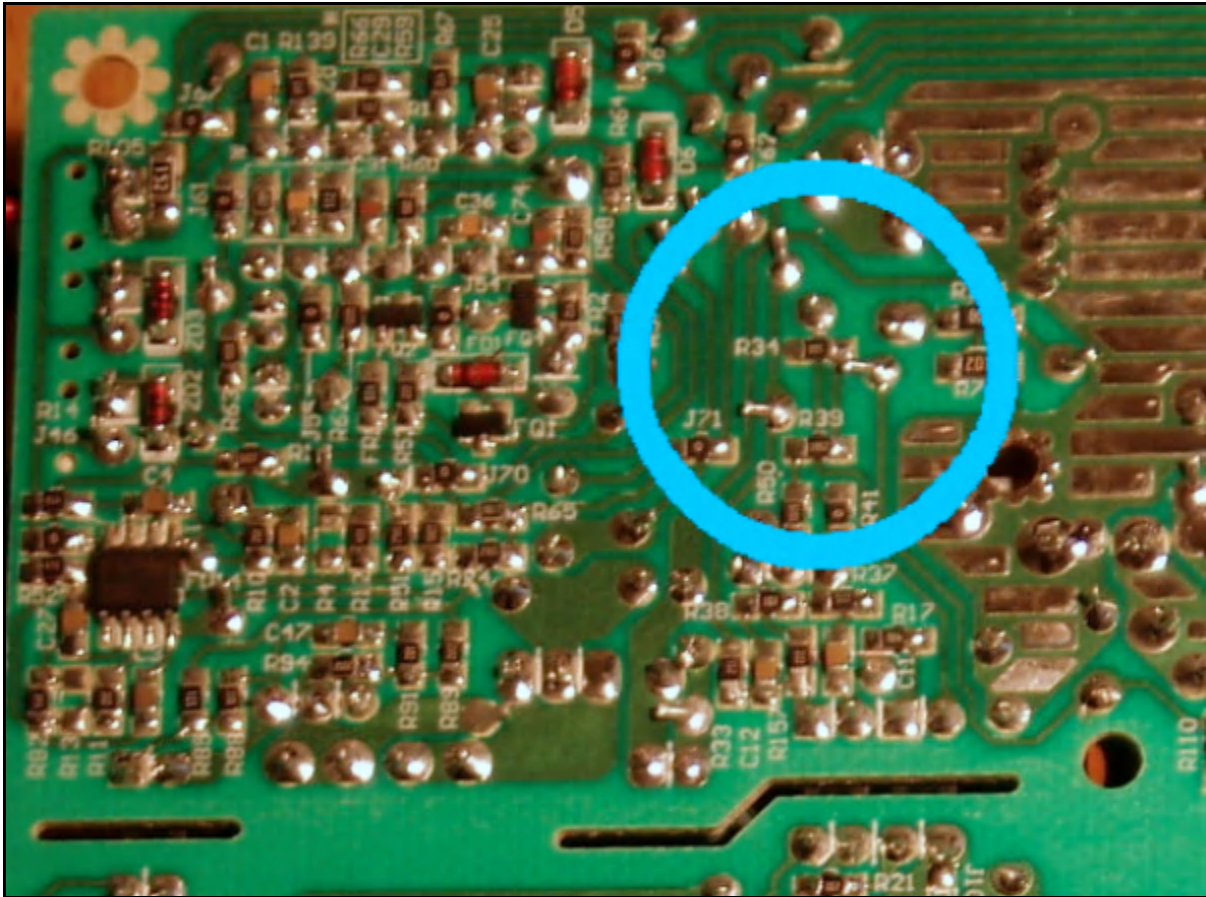

In order to tweak the output voltage you'll have to take off the cover and remove the little resistor numbered R34, and replace it with some wire and a little potentiometer. I've circled R34 in the above picture. The mains power input cable can simply have it's wall-plug chopped off and put straight across your battery pack. While I've run the PSU on my car's 144 volt system fine, I've also heard it'll run happily all the way down to 72 volts!

You may want to chop the tiny plug off and short out (connect the wires to each other) on the thin green & black cable poking out. These wires turn the unit on. By having them short-circuited the unit will always be on whenever there is power coming in which is convenient.



In the above picture you can see the **DC-DC converter sitting in a plastic** box (actually a lunch box) with the little potentiometer positioned on top. Having the potentiometer located somewhere easily accessible is always a good idea so you can adjust the output voltage without having to take things out.

If you can fit it, this would look good inside your component box, away from water mist and as with any component, make sure you have a fuse on the power going in (10A should be sufficient) and a fuse on the power coming out (25A or 30A suggested).

To view the online discussion on the modifications for this PSU follow this link to the EV forum: <http://www.evsecrets.com/recommends/dc-dc-converters.html>
Be warned though, it's a long read!

Vacuum Brake System Installation

Next on the installation list is a vacuum pump to keep your brake system working (as seen in the introduction). If your car was made after the 60's, chances are it'll have vacuum assisted brakes.

By using the available vacuum that gas engines naturally create, vacuum assisted brakes allow you to press effortlessly and gently on the brake pedal while in response your brakes are grabbing hold tightly. Without the vacuum, your brake pedal will turn into an unresponsive brick and you'll find yourself flying through busy intersections at speed with a look of terror on your face.

So trust me, you'll want a vacuum pump! Unfortunately 12 volt vacuum pumps are quite expensive things, as are 12 volt vacuum switches – and you'll need one of those to tell the pump when there's enough vacuum and to turn itself off until the brakes are pressed again.

For this setup you'll need the following 3 things:

- **12 volt vacuum pump.**
- **12 volt vacuum switch.**
- **One way valve** which stops the vacuum leaking back through the pump.



Some converters have found 12 volt vacuum pumps in auto wreckers yards that certain makes of cars (older *Fords* and *GMs*) use. Annoyingly new vacuum pumps can be around \$300 each so by all means search on google, ebay and also talk to your local auto wrecker. You might be pleasantly surprised.

Wiring up your vacuum pump is a piece of cake as there's only 2 wires running through the vacuum switch, however mounting your pump can be a little trickier as these pumps are notoriously loud and have a lot of vibration. The last thing you want is to pull up in a mall parking lot as everyone turns to see your silent car then the *BRRRRRRRR* noise begins under the hood!

Be sure to have a large "Vacuum Reservoir" between the pump and your brake's master cylinder (normally a large casserole pot-shaped thing on the firewall).

Vacuum reservoir tank visible behind front grille:

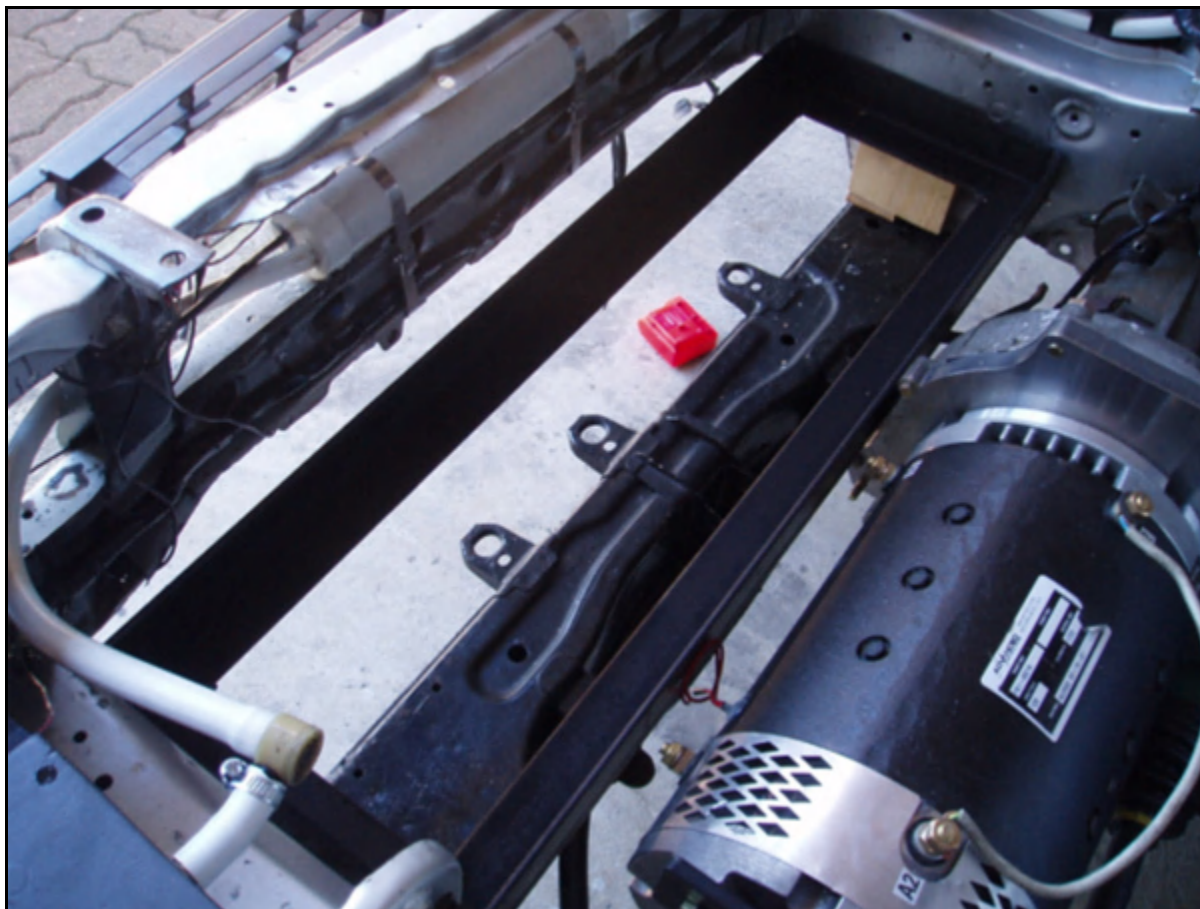

Many converters use a 100 mm (approx 4 inch) diameter PVC pipe with end-caps on each end for their vacuum reservoir. Approximately 4 liters in size should be sufficient for the average car. The larger the reservoir, the more the pump will work but the less often it'll work, and they can be noisy little suckers – literally.

I mounted my vacuum pump in a chunky little wooden box sitting on a rubber mat. It worked, but not enough for my liking. Others have mounted their pumps on large (2 inches high) flexible rubber pads with great results. I've even seen one converter build a rubber hammock in the back of his car so his pump hangs off away from the car frame – it sounds crazy but he promises that it's inaudible!

So **be adventurous** and do what you can to keep the pump off the metal frame of the car and keep your EV as silent as possible to impress passers by.

Power Steering Options

Does your donor car have power steering? If so you may be required by law to keep it in the car. Check with your local DMV or MOT or other automobile related acronym to see what the rules are.

From my experience you have 4 options with power steering:

Option#1: Remove the power steering lines & pump and loop the input & output lines together on your steering rack. While your steering will feel heavier and it may make parking a little less enjoyable, you can save yourself a lot of effort, a chunk of time, and a few dollars by looping your power steering lines. Sadly this option isn't allowed in some countries so before you hack away at your system send your local department of transport an email.

Option#2: Install a separate electric motor to run your power steering pump. This could either be a 12 volt motor or a motor suited to your car's main battery pack voltage. If you're planning to use a 12 volt motor, make sure you use a grunty one, and take note of the amperage drain – it could trip your DC to DC converter. The main benefit of this option is that you can turn the power steering on or off from a button on your dashboard. Because power steering is a power-hungry option, the option to turn it off when not needed will save you that much needed extra range.

Option#3: Install the power steering pump onto the tail shaft of your car's big electric motor. The plus side to this is simplicity. The down side is that when you need it the most (when stopped) it won't work unless you keep the motor spinning. It means you'd have to keep your foot gently on the accelerator, keep the other foot on the brake pedal and try to steer & park at the same time. If you're a natural born multi-tasker then perhaps it's not a big issue for you and you could consider that option.

Option#4: The last option is to replace your power steering rack with a manual steering rack. If your donor car has a model or version made *without* power steering then this is probably the least fuss option. Try to find an automotive wrecker and get your hands on a manual steering rack to replace your power steering rack. It may take an afternoon but you'll save yourself a little complication. Sadly this is only an option for cars that put out non-power steering models as well as power steering models.

Air Conditioning Options

Do you want to keep the air conditioning in your donor car (if it has it?). In some parts of the world air conditioning is a pure essential. Keeping it running in an electric car is similar to the problems faced with power steering: you have to find a way to keep the compressor turning.

Your 3 main options are:

Option#1: Install a supplemental electric motor attached to the car's compressor. This is by far the best method as it can be turned on and off when the air conditioning button is either on or off. The supplemental pump can either be a 12 volt pump or a pump at your car's pack voltage. If you're using a 12 volt pump make sure the amperage draw won't trip your DC to DC converter.

Option#2 Connect your air conditioning compressor to the tailshaft of your car's main electric motor. This may require a bit of plumbing by an air conditioning technician to move the compressor to the tail area of your motor. Unfortunately, like power steering, your air conditioning won't be running if your car is stationary. You'd have to keep the motor turning when stopped to keep the compressor running. If this isn't likely to be an issue for you then give it a shot! Note: when working on your air conditioning system, be sure to extract the refrigerant first. In some older cars the gas used is called Freon (aka R12) which will deplete the ozone layer if released into the atmosphere. Not to mention there are some pretty hefty fines for doing so. Any automotive air conditioning shop can take the gas out for you for next to nothing.

Option#3 Some converters have done some creative things to sort out their air conditioning woes. One popular idea is turning a portable icebox (aka a *chilly bin* or *eski*) into a little air conditioning unit with air ducts coming out from the lid and a 12 volt fan built in. The idea is for air to be drawn in, pushed through piping with icy water around it, then blown out through fans towards the driver. This way you can refill the icebox from your own freezer too.

Chapter #9

Installing a Heater

Unless you live in the tropics, you probably need a heater in your EV. In fact in some countries having a heater is actually a **legal requirement** in order to defog the inside of your windscreen.

But which heater do you choose? There are a few choices to be had with choosing a heater for your EV. You could install a small propane powered heater, or install an electric kettle element into the water pipes of your heater, but in honor of the K.I.S.S rule of thumb (Keep It Simple, Stupid!) we'll look at the simplest & cheapest method – installing a standard 110 volt ceramic element in place of your car's existing heater core.

There are kits you can buy from most EV parts suppliers which require simple installation into your heater core, but I recommend doing it yourself. As long as your car's voltage is 96 volts or higher you should get reliable, instant heat as soon as you turn the key.

If you're planning on a lower voltage than 96 volts, you may find the performance of a household 110 volt element a little lackluster. In which case I suggest you look into installing a small propane heater with a little propane tank (quite effective) or as a last resort, using a 12 volt heater. 12 volt heaters are quite gutless and unimpressive in most cases because of the low voltage only being able to pull limited amperage.

To create your own 110 volt in-dash heater you'll need the following:

- 1:** A 110 volt ceramic heater (from any typical home wares store)
- 2:** A DC to DC relay to turn the heater on & off from a 12 volt dash switch



3: A tube of high temperature sealant to support and insulate the element inside the old heater core. This is a typical 110 volt ceramic heater. Not sure how to pick out a ceramic heater from the others? It's easy, have a close look at the element behind the grille:

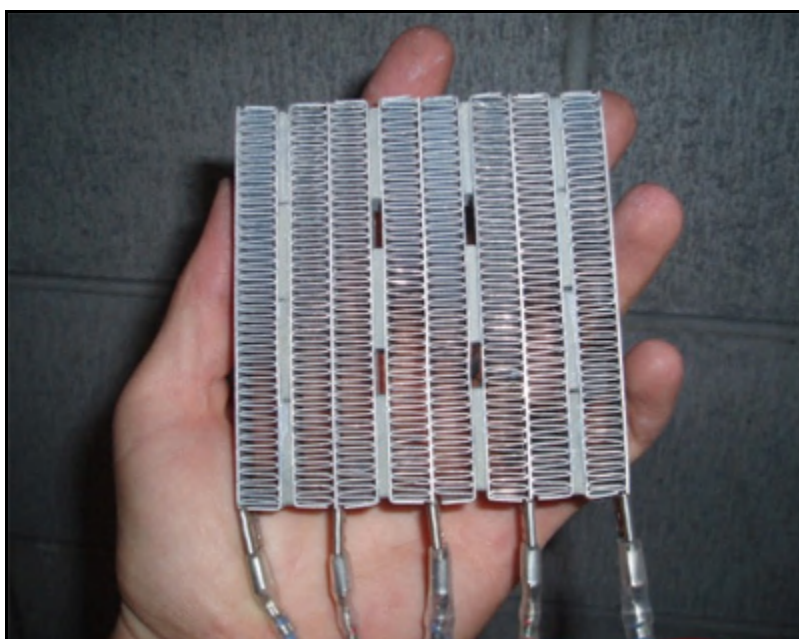

See the little blocks in between each element? Those are ceramic and make these element's ideal for EV heater applications. Make sure the heater you buy has those little blocks.



Next, remove your car's heater core. Now this is normally easier said than done and in extreme situations may require you to take the lower half of your dashboard apart. The pipes feeding your heater core can be cut off as they're no longer needed, though be warned, they're probably still full of water! If you have the spare time to carry on with other projects, I recommend leaving the core to dry out for a few weeks. Forcing hot air through it via an electric heat-gun or gas torch will speed the process up if you're in a hurry to get your EV on the road.

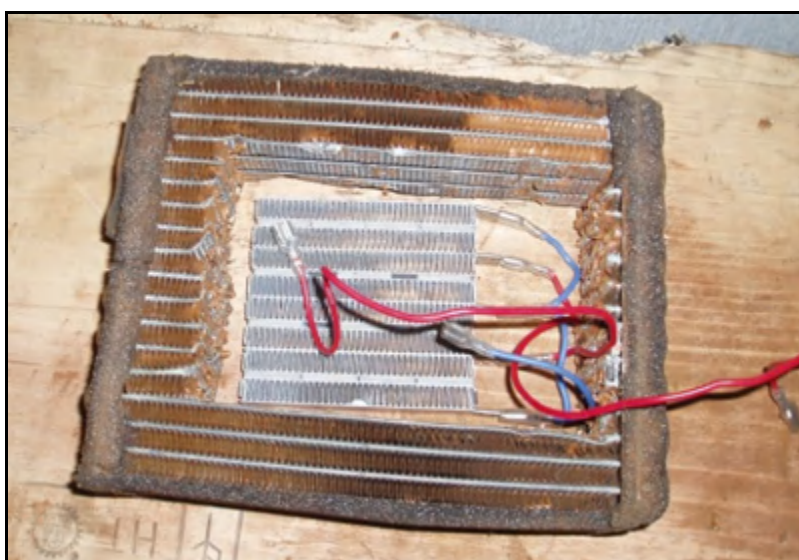

Once your heater core is dry, place your ceramic element on top and trace around it with a marker or screw driver, allowing a few millimeters of extra space. Once that's done it's time to get out a hacksaw or grinder and cut out the space. The ceramic element should be able to fit inside the hole with a little clearance around it.



Grab your high temperature sealant and build a barrier around the inside of the heater core to stop the element touching the metal core. You'll most likely have to leave it overnight to cure. For safety, once it's cured grab a multimeter and make sure it has a high resistance just like an insulator should.

Some sealants may have a metallic content and allow high voltage current to leak through – though this is rare. At this stage it's easy to change sealants if you find it doesn't offer good resistance & it's certainly better to find out now rather than after your heater's installed.



Place your element inside the core and continue sealing it in. No part of the element should touch the metal heater core. Afterwards, block up the hole in the heater core by placing a piece of metal over it – but make sure the metal does not touch the element directly!

Like the photo above, there must be a layer of high temperature sealant between the metal blocking plate and the element. Once it's cured, make a new hole in the end of the core, or use one of the existing pipe-holes to run the cables through. I recommend putting some sealant or soft glue in the hole too as it'll stop the wires chafing on the sharp metal edges while driving.

You should now have 2 different colored wires coming out of the heater core, one will be *negative* and the other *positive*. Don't worry about which one is which – heater cores like these can be wired up either forwards or backwards as they're basically a giant heat-generating resistor.



You're going to need a way to turn off this high voltage heater element from a standard 12 volt dashboard switch, in which case you'll need a 12 volt relay that switches on a much higher voltage. A relay like this *Omron Solid State relay* is one option. (no moving parts)

They're normally around \$25 from electrical suppliers but through the Internet you're bound to find one at a cheaper price.

Here's how to wire it up:

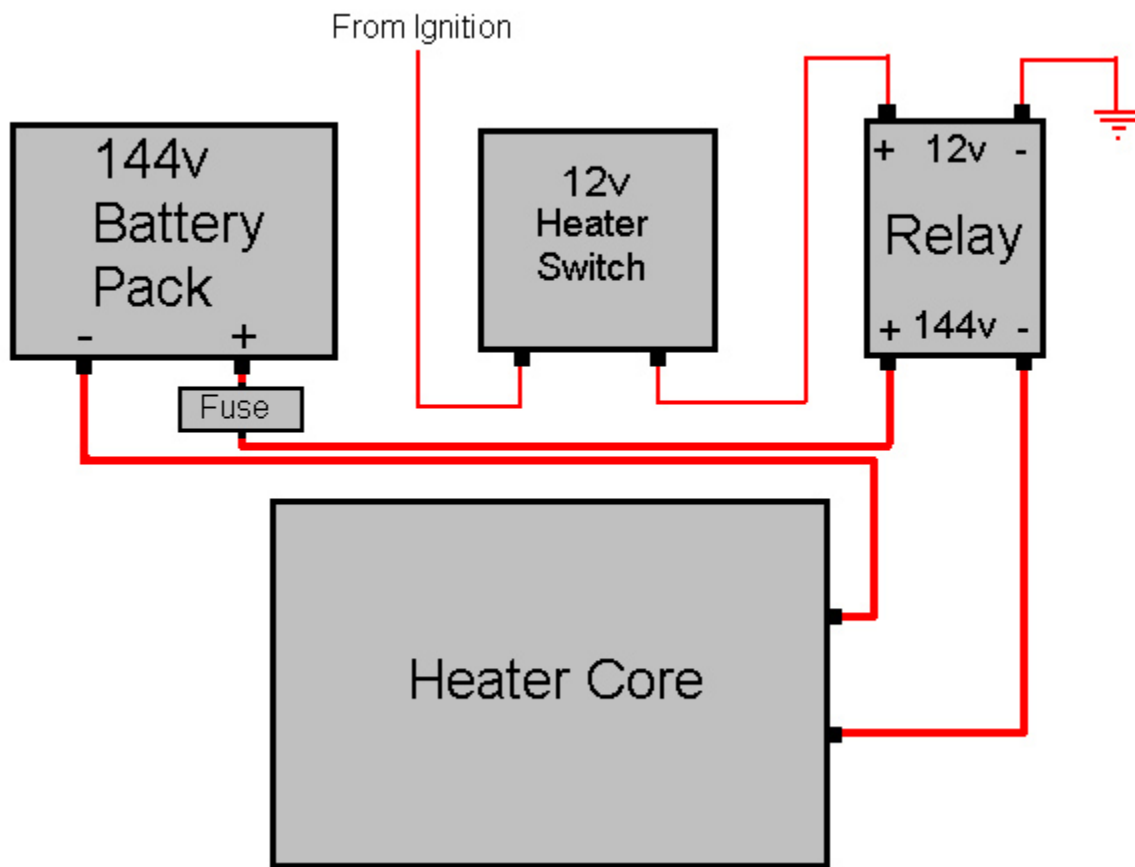

Please note that the above picture does not include the contactor or circuit breaker, it's only to show how the relay controls the voltage to the heater core. The diagram also displays a 144v system but it's only for illustration purposes. See how the 12 volt switch running from your accessories power supply can turn on the high voltage current? It's very convenient and saves running the high voltage cables through the passenger compartment of the car – which is not allowed in many countries.

Be aware that you should always fuse any circuit running off the car's main battery pack. If there's a short circuit without a fuse you can guarantee some fireworks coming from your dashboard. While setting your dashboard on fire will warm your car up quite nicely it's certainly not recommended - use a fuse for safety's sake.

Chapter #10

Installing the Batteries

Now is the time to buy your batteries and your charger. Now is also a good time to double-check your measurements to ensure the batteries will actually fit into the car. If you're welding or bolting together your own battery racks, make sure they'll be able to stay in one place in the event of a serious accident.

In New Zealand, the rules state that the battery rack must be able to withstand a force 20 times the weight of the batteries in the event of an accident. This is a good rule of thumb to aim for as the last thing you need in an accident is your batteries upside down, leaking acid and shorting out.

A popular (and inexpensive) metal used for battery racks is “*Angle Iron*”, which is an **L-shaped length of steel** available from most scrap dealers or engineers' workshops for next to nothing.



(“Angle Iron” being used to fabricate battery mounts)



Once you've bolted or welded your mighty frame together to support your batteries, make sure you round off any sharp edges with an angle grinder. In the event of a serious accident, sharp edges bolted to sheet metal (the trunk floor for example) will tear through the metal as if it were soggy toilet paper.

When bolting or welding your battery racks into the car, make sure you are attaching the racks to the frame of the car, not the engine bay or trunk paneling. You should be able to jump up & down on your racks afterwards with absolutely no movement. Each car is designed differently so if you're in doubt, ask a mechanic.

Once your batteries are installed into the front and/or back, you're going to need to look at **venting**. Lead acid batteries will bubble and release hydrogen gas during charging. This is normal, though you need to vent this gas away from the batteries and the car to eliminate the risk of those pesky explosions when you turn the key and the contactor arcs closed.

In most countries, batteries in the front of your car will not need venting as they're outside the passenger compartment; this is the same for batteries sitting in a tray or box on the back of a flatbed pickup truck or utility.

Batteries in the trunk however are considered *inside* the passenger compartment and will need to be in a sealed box with a vent and a fan to extract the hydrogen gas outside.

In many countries the law states your **battery box** must be:

- *fire resistant,*
- *acid resistant*
- *waterproof.*



I made my rear battery box (pictured above) out of thick wood paneling, then applied 2 generous layers of *POR-15*, a rust-neutralizing resin-like paint which is fire resistant, acid resistant and waterproof. It did the job quite neatly, was cheap, and it ticked all the right boxes for safety.

As you can see, I placed my battery box **above the trunk floor for simplicity**. If you need your trunk space, I recommend cutting into your floor and placing the batteries rack lower down towards the ground.

Once your batteries are into the box, it's time to secure them in... securely!



Some converters will place an insulated bar across the top of each row, like above. It makes for a strong yet inexpensive solution.

Make sure there's no lateral movement in the bar, or you could find a row of batteries shorting out and exploding- which makes for great conversation, but costs a lot to fix.

Another cheap method that others (including myself) have used is Bandit straps:



These are stainless steel straps that can be tightened and fastened with a special tool, then clamped down with special clamps. **These straps are very strong** but can also be a short circuit hazard and should be insulated through a thick PVC flexi-tube as above.

Once your batteries are secured in the passenger compartment, you need to put on a sealed lid. I made mine from the same wood with the same resin shell painted on the inside, with a silicon strip between the battery box and the battery box lid.

Now that the box is complete, you need to consider the removal of the hydrogen gas when charging & driving. Be sure to use a 12 volt DC "brushless" fan for the extraction as they have no risk of sparking. 12 volt brushless fans are cheap, easy to find (<http://www.eBay.com> has many) and quite efficient; typically using only 5 to 10 watts when running.



Once you have your fan installed into the box you'll need to have it running both during driving and when charging. Not only that, but in some countries it's a requirement to have the extraction fan run for 5 minutes *after* you've finished driving or charging.

Don't worry though; the easy solution to this problem is to run the fan through a turbo-timer. Turbo timers are designed to extend the life of the turbocharger by keeping the engine running even after the driver has turned off the key and walked away. **Turbo timers** are simple 12 volt devices that usually have 4 wires: an "always on" power input wire, a supply wire from your car's ignition, a "power out" to your extraction fan, and an earth wire. Check the specific instructions with your turbo timer before wiring it in.

In order to have the fan turn on while charging, you may wish to wire a simple switch onto your gas cap that allows 12 volts to flow to the turbo timer when the gas cap is opened, and then the turbo timer will continue to run 5 minutes after you've finished charging and closed the gas cap.

The extracted air should flow straight to the outside of the car. Most commonly I've seen it done through the floor of the car. As far as bargain hunting goes www.Ebay.com is by far the best place to find cheap second hand turbo timers.

Chapter #11

Wiring Up The Batteries

You're almost there! Now it's time to get some cable for those batteries, then cut it, crimp it and connect it!



For all street conversions I recommend 2/0 gauge (70mm²) welding cable as your **main battery cable**. It may be slightly more than the average conversion needs but you'll have no problems with resistance or your cable overheating from having a heavy right foot! You could try a 4/0 or smaller but the risk of cables overheating grows with each step down in cable size.

For the short cable lengths in between batteries, some converters have used solid copper bars. It's faster and cheaper than having cable cut & crimped. Like anything however, it has its drawbacks: welding cable offers flexibility between the battery terminals while driving but solid bars do not so if you're not careful in your design you might notice battery acid leaking around the battery terminals from physical stress after a few months of driving. Also, be sure to insulate the bars with thick heat shrink if you're planning on using the copper bar method.

Welding cable is recommended because it's designed for high amperage loads while still being a fairly flexible cable for its size. It achieves this by using many fine conductors inside the cable, instead of a few thick ones. Unfortunately it's not a cheap cable, so shop around. Welding suppliers are often the best places to ask, but some EV parts suppliers buy in bulk and can also offer good pricing.

Either way you'll need to measure just how much cable you're going to need.

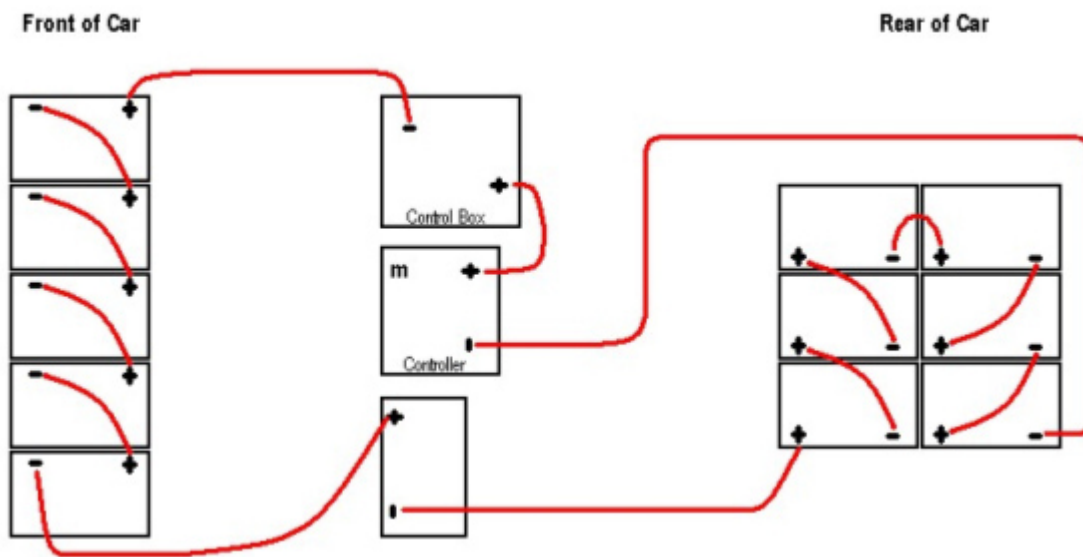

As an example, this is the basic wiring layout of my own conversion. The electric motor is removed from this particular diagram, but it will give you an idea of how you could run your own cables through the car and how many lengths to have.

I found using a thick length of rope was useful to gain an understanding of how a large cable could fit into the car's existing nooks & crannies. Get underneath your car to look at your cable route options and take plenty of photos for planning later.



Here's an example of **the main positive and negative cables running between the front and rear battery pack in my car**. Once again, don't run any high voltage cables through the passenger compartment of the vehicle.

You can also see the black recharging cable in the above photo alongside the two battery cables. As you can see, I've run the main cables inside a flexible *PVC sheath* to protect them from stones, water and mistakenly driving over sharp lawn ornaments.

When you've measured out & purchased the required lengths of cable, it's time to look at lugs to go on the end of the cables. Depending on your type of battery you'll probably either be using a bolt-on spade lug or a wrap-around lug. Some batteries have the option for both.

Notice this battery has a threaded terminal and a post terminal on each polarity? Choice is always a good thing.



Your cable supplier will probably stock the lugs required for your cable size, it may be worthwhile having them crimp them for you.



Though if you're looking to save a bit of money you can cut & crimp them yourself quite easily – if you have the right tools. Some EV parts suppliers loan out their cable cutter and crimper to customers - check with your local supplier. The welding supplier I purchased the cable and lugs from was willing to crimp them for nothing!

The 2 most popular methods of crimping your lugs are:

- *Hexagonal Crimp*
- *Dimple Crimp.*

A *hexagonal crimp* squeezes the lug onto the cable from 6 directions. This is by far the most secure and lowest resistance method. A dimple crimp presses onto the lug primarily in one place. It does the job but there's always a higher risk of increased resistance (by not being in perfect contact with the cable's entire circumference) and a higher risk of the lug popping off under stress.

Naturally, *I recommend the hexagonal crimp*, though many would argue the difference isn't noticeable.



Before you crimp be sure to put some loose heat shrink over the cable & lug area. When the length is crimped, slide the heat shrink over the lug and use a heat gun or gentle flame to shrink it down.

Remember to use **red shrink for positive terminal** lugs and **black for negative terminal lugs**. It's little things like this make your conversion look professional when strangers are poking, prodding, and taking photos of your work.

Chapter #12

Powering Up Your Electric Vehicle

Time to get your car running on pure electrons at long last and time to wire up all those EV gadgets!

Connecting The Main Cabling

We'll start with a schematic diagram that I've simplified and made very basic for non technical people to make sense of:

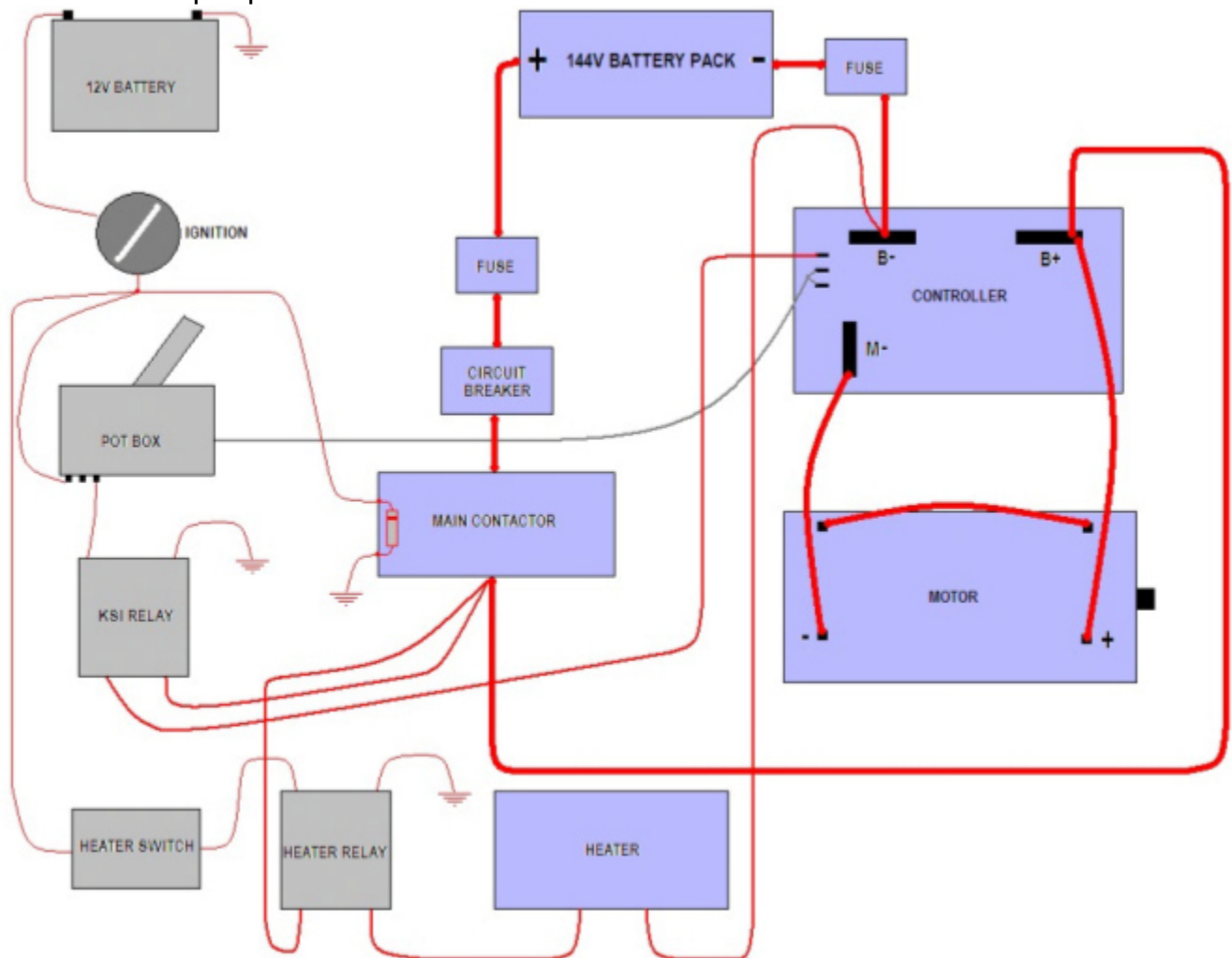

It may look like an octopus at first but if you start from the top left and follow your way through you'll see it's not very complicated. To keep things simple, I've omitted the High Pedal Lockout relay, and the rear battery extraction fan as they're 12 volt items that powered through the above high voltage wiring diagram.

- **The thin red lines** are 12 volt circuits crucial to the high voltage circuits.
- **The medium sized red cables** are low amperage loads off the high voltage circuit such as the heater relay and the Key Switch Indicator relay.
- **The thick red lines** are the high voltage, high amperage cables that carry the power through the motor, controller and fuses.

The controller shown in this simple diagram is a **Curtis 1231C**. You should have received a wiring diagram for your own controller model which you should use.

Every car is different, and every conversion is different so please use the above diagram *as a guide only*.

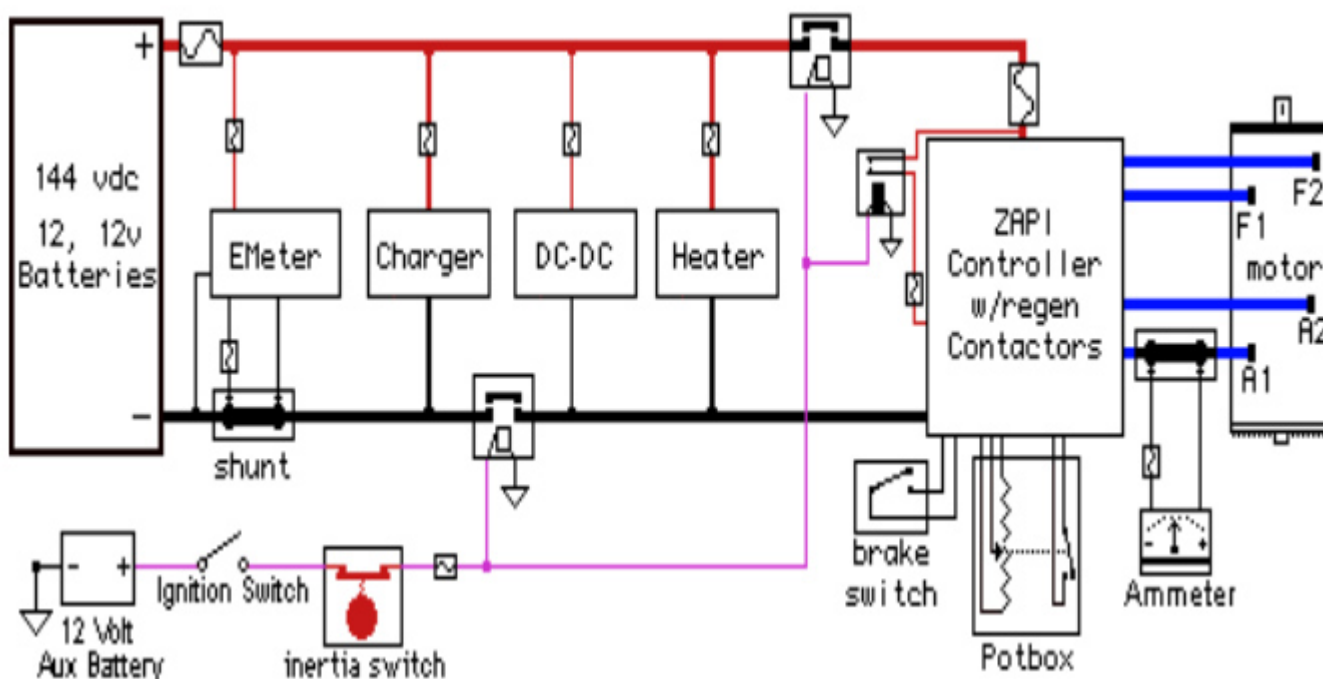

Image courtesy of Jerry Halstead

Shown above is another example of a 144V circuit diagram. This one used a *Zapi brand controller* with regenerative braking, where the car would recover some electricity when you press the brake by turning the motor into a generator.

Regenerative braking is not a common option for DC voltage controllers and from my experience people have found it not to be reliable (in DC voltages) with controller failure a constant possibility.

Most AC voltage controllers have this function built in as standard due to the unique characteristics of AC controllers. Unfortunately the cost of AC controllers for the home-converter and hobbyist often outweighs the typical 5 to 10 percent (maximum) range that's recovered during regenerative braking.

Currently I'm only aware of 2 DC controllers that offer regenerative braking: **Kelly** and **Navitas**.

Each will have specific wiring requirements and will come with their own instructions. Be sure to follow those instructions to the letter and double check your connections before using regenerative braking to maximize the lifespan of your controller.

Leave connecting the batteries until the absolute last moment. For now it's the low voltage stuff only, and the safety devices such as fuses and circuit breakers. If you're using a control box to house your smaller components, now is the time to wire it up.



In the above example from my own conversion, I've run the cables underneath the box to keep it tidy. You can see the 2 *Omron Solid State relays* on the lower left, powering the heater and the controller's on/off control switch (*KSI relay*).

These 2 relays are fed from the dormant side of the contactor (see the red wires coming off from the left and going under the board?). On the top left is the main contactor, controlled by the car's ignition key. On the top center is one of the car's *two 500 amp DC fuses*, below it (bottom center) is the *shunt*, and on the right is the *circuit breaker* with the "kill switch" cable running through to the dash board. For making very short connections such as the connection between the shunt and the fuse (center of box), I recommend using a solid piece of copper:

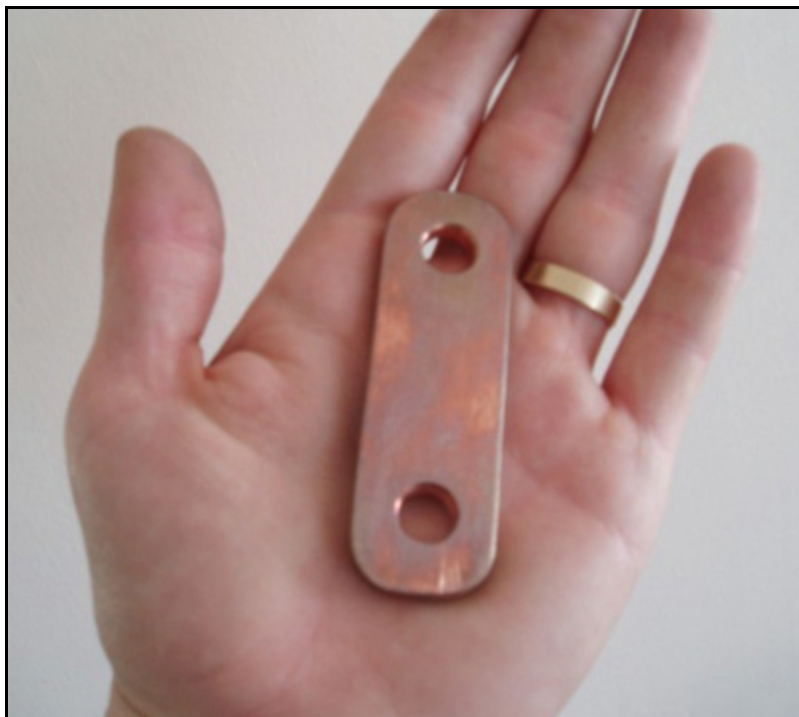

For short runs in cramped conditions these copper bars are ideal. If running these underneath your control board I recommend insulating them with heat shrink in case un-gloved fingers touch both a copper bar and a battery terminal at the same time.

Remember, the voltage will be dangerously high and DC voltage burns are more severe than AC voltage burns.

Just remember not to rush - and *relax!* As long as you take appropriate safety precautions electric vehicles are just as safe to work on as gasoline vehicles.

To clarify this important part of the conversion, let's go through and check each component one by one in a checklist:

The Contactor

The contactor needs to be wired up through a High Pedal Lockout relay as in the diagram in Chapter #8. It should not “close” the circuit (click on) if your foot is on the gas, and when it does close, it should stay that way until the key is turned off.

Check with your controller's manual to see if they recommend installing a diode. Some instructions suggest using a resistor across the high voltage terminals of the contactor but if you're using the simpler “one contactor” method described in this ebook, I do not recommend installing the resistor as it will leave your system effectively powered up all the time.

The DC to DC converter

This should be wired up to the 12 volt battery with positive to positive and negative to negative. The “on” signal wires should be connected together so that when the ignition is on and the contactor closes, the high voltage part of the car will become alive and the DC to DC converter will automatically switch on. The high voltage positive line should have a fuse (a 10 Amp fuse is normally sufficient).

High Voltage Fuses

You should use at least two high voltage fuses. One before your contactor on the positive (+) side of the battery pack and one before the negative (-) of your battery pack. The more fuses the better, especially if your pack is split into two sections (hood & trunk).

Circuit Breaker

The circuit breaker should connect in the positive (+) line of the high voltage circuit and must be accessible to operate from the driver's position, but the high voltage lines mustn't come into the passenger compartment. As I mentioned previously, a pull switch running from the dash to the arm of the circuit breaker is a good idea. Make sure the circuit breaker is adequate for your controller's rated amperage.

The Shunt

The shunt should be on the positive (+) side of the high voltage circuit. The power will flow through this and two wires will run from either side of the device to your ammeter's input.

Ammeter and Voltmeter

Each of these will require a 12 volt + and - input to operate, as well as a high voltage feed from the + and - of the battery pack (fused) for the voltmeter, and a high voltage feed from the shunt (also fused) for the ammeter. Check with the installation instructions that come with your meters first though as some have specific requirements.

KSI Relay

Curtis controllers use a KSI relay to tell the controller when it's time to power up and operate. I had mine operated by a Solid State Relay whenever my foot pressed on the accelerator which was signaled from the switch at the bottom of the pot box. Check to see if your controller actually uses a KSI relay.

Inertia Switch

The inertia switch or "crash switch" should be attached to the frame of the car near the front, but not actually on the front of the car (such as a fender). Your contactor input should run through the inertia switch via the two wires poking out. Feed your contactor's 12 volt signal in through one and out through the other, then take it to the contactor.

Vacuum Pump

If possible make sure it's installed on a rubber cushion to minimize the vibration. To power the unit, feed it on a fused 12 volt supply from your ignition through the vacuum switch so that it only operates when the key is on.

Vacuum Switch

There should be two or three terminals on the vacuum switch: Normally Open, Common, and Normally Closed. You'll want to run your (fused) 12 volt positive supply into to the Common, then out to the pump through the Normally Open, so that when the level of vacuum lowers, the switch will close (liven) the circuit for a short time until vacuum is restored, the open (kill) the circuit.

Excluding the charging system (covered in the next chapter) that's the major components catered for. All that's left now is to power it up!

Final Check

Before connecting your battery cables, turn the ignition key and power up the 12 volt systems. Try to "start" the car. Your ignition should function as normal and your contactor should click closed and stay closed.

Your heater relay and KSI relay (if installed) should power on when the heater switch or accelerator is pressed. Check your turbo timer and extraction fans. If you haven't done so already, check your voltmeter works by connecting it across a low voltage battery. Check your inertia switch operates when clunked with the handle of a screw driver – the contactor should pop open. Check your vacuum switch operates then switches off when the vacuum level has been reached.

If you're satisfied everything is working as it should be with no high voltage supply, then you can begin connecting it up. Double check your wiring diagram supplied with your controller before connecting your individual battery jumper cables. Make sure the final positive and negative connections from your battery pack are going to the right connectors on your controller.

If you're satisfied again with the high voltage layout and it reflects your controller's wiring diagram then let's get connecting.

Raising The Car for Safety

First, raise the drive wheels off the ground. If the car is rear wheel drive, raise the rear wheels off the ground, if the car is front wheel drive, raise the front wheels off the ground. If your car is four wheel drive, then your car will probably explode when you turn the key. No I'm not serious, that was little comic relief to de-stress this exciting and nerve-wrecking part of the conversion!

Insulating Your Tools

With your drive wheels off the ground, now is the time to tape up all your tools with electrical tape. This will help prevent a short circuit damage to your batteries if you drop a spanner onto the battery terminals. It has happened before so eliminate that risk.

Connecting The High Voltage Cables

Begin connecting the cables to your battery terminals one by one. You should have some high voltage gloves (available from safety shops) to wear once working with voltages over 48 volts. DC voltage can deliver some quite serious burns and there's always the possibility of a high current flow through your hand or arm if it gets in the way of your battery pack. You'll probably find yourself using them in the future so they're not a bad investment.

Remember that the positive (+) of one battery connects to the negative (-) of the battery next to it. This connecting in "Series" increases the voltage one by one as mentioned in chapter 3. Don't try connect the positive (+) and negative (-) of the same battery together, that will result in a large spark, a possible battery explosion and a voided warranty.

Eventually you'll have your pack voltage reaching your controller, only broken by the circuit breaker and the main contactor. As long as all your fuses are in place and your wiring is correct (as per the instructions for your controller), connect the circuit breaker first. If you have the positive (+) high voltage side reaching the

contactor and you've double checked your wiring, it's now or never. Time to turn the key.

Providing your cabling is correctly configured for your particular controller and motor, your motor should be able to spin by pressing the accelerator. Make sure the car is out of gear first and don't over-spin your motor or it will disintegrate. If you're certain your car is stable and your drive wheels are off the ground you can put the car in gear and try spinning the wheels in all gears including reverse. This will prove that your gearbox is working and that your motor is spinning in the right direction for your gearbox.

By this stage you're either doing 2 things: you're either scratching your head figuring out why it's not working, or your grinning from ear to ear and jumping around the garage in elation!

If your car's not running it's most likely going to be one of 3 things:

- *your battery wiring (including fuses & the circuit breaker),*
- *your controller wiring, or*
- *your contactor/KSI relay wiring.*

If you're having problems, turn off your key, then open (kill) the circuit by pulling the circuit breaker and go through your wiring point by point. If your car's running then treat yourself to a well deserved run up the road and back! Drive it easily at first. Get a feel for which gear suits which speed.

Like many EVer's you may find that you only need 2nd gear from a standstill to approximately 40 mph. Remember, don't over-spin your motor! Make sure it's always in gear when your foot is on the accelerator for safety. Different motors have different maximum RPM ratings. Advanced DC motors typically "red line" at around 6000 RPM.

Checking For Problems

Check for knocks and clunks while driving. Run a small distance at first then check for motor temperature. It should only be warm after a mile or so. Check your batteries too - make sure they're not gassing heavily. As every car is different I can only suggest you take your time and drive & listen carefully! If you find any clunks or faults, now is the time to fix them. Congratulations on achieving your first "EV grin" - you're certain to have plenty more in store! Be sure to enjoy this moment! You've worked hard to get to it!

Chapter #13

Installing Your Charging System

The fourth most vital part to any electric car is its charging system and you have **2 main options to choose from:**

- *a single mains-powered "pack" charger, or*
- *individual 12 volt chargers for each battery.*

I've tried both methods and I'll explain the pros & cons so you can decide which suits your needs.

Mains Powered Pack Charger

By far the simplest and most flexible method, this is a single charging system which is usually installed into the trunk of the car. It has a positive (+) and negative (-) output which simply connects across the positive (+) and negative (-) terminals of your main pack, charging all batteries in the loop.



One popular pack charger is **the Zivan NG3** (pictured above) which can take both 110 volts or 230 volts AC (depending on your model) and delivers your desired pack voltage in DC volts. They're also protected against overloading, overheating and short circuits.

These chargers are intelligent and reliable and if configured correctly for your individual pack (done by the retailer), it should push the life of quality new batteries well beyond 3 years - if the batteries are looked after of course.

These chargers can be installed in the trunk in just a few minutes and depending on your country/state laws you can simply put a standard household plug on the side of the car to charge – often where your fuel filler used to be! That gives you the advantage of “opportunity charging” at malls, friend's houses etc.

The downside is simple – the cost. These chargers fluctuate in price but expect to pay between \$1200 US and \$1500 US for one brand new. Of course there are many other charger models out there too such as **Elcon** and **Russco**, and often these will pop up on eBay and in EV forums. Bargain hunting for these popular chargers is something to consider if you're patient.

Trunk mounting or external mounting?

The most convenient is trunk mounting of course, though in some countries this requires the car to be electrically certified as the car has effectively become an appliance. This is an extra cost and means you can only use a particular type of outdoor plug, limiting your opportunity charging options. Check with EV owners in your area to see the rules on trunk mounting your charger. Another downside to trunk mounting is the weight. A typical charger can weigh around **22 pounds** (10 kg) and extra weight is not an EV's friend!

Externally mounting your charger in your garage for example will simplify the overall connection, allowing you to use a choice of plugs to join the charger to the car's socket, and taking the recharging leads straight from your gas cap (for example) to your pack's positive (+) and negative (-) terminals. It also means the weight of a charger is excluded from your EV, and that the car isn't required to undergo electrical certification. The downside to this method is that it limits your charging options. You can only charge where your charger is, which means if you want to go to a friend's house you have to take your charger with you.



When installing any charging system, especially an AC "mains" system, be sure to connect the correct terminals onto the plug/socket setup in place of your gas filler. **This is vital.** If you get the wiring around the wrong way and your charger is in contact with the car's body then your car could become "alive" and touching the car body could allow mains power to travel through your body. If you have any doubts, check out the wiring colour code for your country and seek professional advice before attempting to wire in the AC part of your charger. Do it once and do it right.

Also ensure your contactor opens when your gas cap opens. For this I recommend installing a safety switch that opens the contactor when you pop your gas cap. Simply run your contactor's 12 volt + and - lines through a waterproof trip switch on the door of your gas cap.



If you're looking to cut costs again but want to keep a mains pack charger, you could consider looking into a "**Bad boy**" charger. This isn't recommended for novices, as it basically charges your car by turning 120 volts AC into DC through rectifiers and letting it loose across your battery pack.

This method can work and is cheap, but it's often crude and if left unattended can cook the occasional battery pack. Bad boy chargers are ideally suited to packs of 96 volts to 136 volts and can be dangerous for the electrically unsavvy.

For information on building your own Bad Boy charger, check out the following link:
<http://www.electric-cars-are-for-girls.com/battery-charger-schematic.html>

Using the One-Charger-Per-Battery Method

While a little more complicated than simply installing a single charger in, the one charger per battery method is much cheaper. This method involves installing a single 12 volt car battery charger to each battery's positive (+) and negative (-) terminals. If you have a 96 volt system, you'll need 8 individual chargers, if you have a 144v system you'll need 12 of them!



This was my EV's original charging system. As you can see I used 12 chargers, plus a 13th charger to charge the accessories battery. This method saved me approximately \$800 US, though like any cost cutting method, it can have its **drawbacks**: mainly "Voltage Drop" and the slow speed of charging.

If you're interested in this method you need to take those 2 main things into consideration. You'll need at the very least 10 amps output from each 12 volt charger or you'll find yourself charging for 20 hours for 10 miles of range. If you plan on using high amperage chargers, keep in mind just how much current you'll be drawing from the outlet in your garage.

For example, using twelve 15 amp (12 volt) chargers would draw 180 amps at 12 volts. That equates to 2160 watts (**voltage x current = wattage**). This isn't a big issue for your average 240 volt outlet (drawing 9 amps), however on a standard 110 volt outlet that's almost 20 amps (**wattage ÷ voltage = amperage**).

That sort of current on a standard household point could overheat the wall plug. You'll require either smaller amperage chargers or a higher voltage/amperage outlet.

Voltage drop is something that affects DC voltages (more so than AC voltages) and it's relative to the length of the conductor. In a basic example, if your charger sends 12 volts down a long cable with perhaps 4 meters of cable between the charger and the battery, only 11 volts might reach the battery terminals, and with 12 volt chargers, every little volt helps!

This means that if your battery chargers are too far away from your batteries, they'll never actually reach a completely full charge which will shorten their life.

To minimize voltage drop, you simply need to keep the distance between the charger and the battery very close – ideally with each charger mounted inside the car next to the battery it's charging. In most cases you can drive your EV with a charger connected to each battery permanently with no problems as the chargers can only see a 12 volt battery in front of them.

Just make sure your contactor is open and the main circuit is dead before you turn on all the chargers. For this I recommend installing a safety switch that opens the contactor when you pop open your gas cap. Simply run your contactor's 12 volt + and - lines through a waterproof trip switch on the door of your gas cap.

While I don't recommend it, if you do decide to mount the chargers outside the car, you must keep the cable as short as possible to ensure each 12 volt battery is actually reaching its maximum charged level (13.8 volts). You'll also need a multi-pin connector to take all the positive (+) and negative (-) pins from each charger to each battery.

On a 144 volt system for example you'll need a plug & socket with 24 pins, each capable of the sustaining the amperage your chargers can deliver. I used (and can recommend using) **Lap Kabel multi-pin plugs & sockets** as they're weatherproof, dead easy to terminate and capable of taking respectable amperages.

2 things to keep in mind with the multi-charger method:

1. Firstly, in case of any short between terminals install a fuse on *each* negative and *each* positive lead running to each battery terminal. On a 144 volt system it means installing 24 fuses, but it's well worth it.
2. Secondly, low quality car chargers that have earth pins on their plugs have the risk of back feeding the car's high voltage circuit and causing a short circuit. I observed this happening on two chargers I was using, where 144v DC back-fed from one battery's negative (-) charging lead, through the charger and then onto the "earth" connection of it's 230v input. This leakage traveled along the earth line that all the chargers were connected to and then shot back up the earth of another charger in the group, back through my multi-pin plug on another negative (-) line and towards the negative of another battery in the pack.

This bizarre situation happened in the blink of an eye and caused a short circuit when I tried to plug my car in. It destroyed two pins of my car's multi-pin plug and took a very long (frustrating) time to diagnose. From this I've learnt not to use car chargers with earth connections unless they're very reliable and there's no chance of leakage through the earth pins.

If you find yourself in a situation where you're uncertain, don't rush. Recheck your wiring and if you're still in doubt ask for instructions from another EV owner or an electrician. The last thing you want is component failure or worse, an electric shock.

Chapter #14

Preparing Your Electric Car

For The Road

Preparing Your EV For Inspection

Congratulations on getting your EV running! Depending on your country or state you will most likely need to take your EV for an inspection of some sort. In New Zealand & Australia the rules are fairly strict to ensure that home-built electric cars aren't likely to catch fire just sitting in traffic like their gasoline powered counterparts have been known to do!

The inspections vary in their thoroughness. Some take half a day and cost over \$500, and others are simply ticking a box at your local Ministry of Transport or DMV and driving away! If possible, find a copy of your local electric vehicle inspection checklist before you get to the actual inspection.

To give you an idea what the rulebooks look like I recommend using the New Zealand rules available in 3 parts here:



http://www.evsecrets.com/doc/nz_ev_requirements_1.pdf



http://www.evsecrets.com/doc/nz_ev_requirements_2.pdf



http://www.evsecrets.com/doc/nz_ev_requirements_3.pdf

Even if you're not in New Zealand, the rules are detailed, comprehensive and quite strict, covering everything from power steering to timed battery venting. If you follow these strict rules to the letter you'll generally fly through any inspection (as I found), though check with your transport agency first. In the unusual instance that your country or state has no specific rules on conversions, the New Zealand rules are a very safe guide.



To help with passing your car's inspection, first tidy your car! No one wants to inspect a dirty or messy car. Give it a vacuum and clean your windows. Next, organize and secure any loose wiring in both the passenger compartment and the engine bay. Remember, if it **looks** tidy, the inspector will want to assume it's also **built** professionally.

If you're confident it's clean, tidy & organized then pretend you're a ruthless inspector (aren't they all?), grab a copy of the inspection rulebook and take half an hour to pour over every item on your car as if you'd never seen it before. If possible, get a friend or neighbor to do this for you and ask him/her to be critical. If your car does fail the inspection don't stress out. Correct the problem, go back and finish the inspection.

How To Get Your EV Insured

After all the effort you've been through I recommend insuring your new baby. In many countries car insurance is compulsory but if insurance is optional in your part of the world I'd recommend it anyway.

Unfortunately our friends in the insurance trade will see that your electric car is a "high risk" or "heavily modified" vehicle which means higher premiums than its gasoline powered equivalent. Time to start calling around for quotes. Start with your normal insurer first. Also, you may be entitled to a discount if you use the same company that insures your home.

You may need to get the car appraised by an appraiser who specializes in things like hot rods or restorations. Often, the insurance company will accept your receipts for the cost of conversion to establish a value.

There are also a handful of professional conversion web sites that offer used conversions for sale which can help establish a comparable value for the car for insurance purposes.

If you're still not having any luck finding a company to insure your car you could try using the insurance companies that "boy racers" use. You know the ones, the guys & girls that lower their hatchbacks and sedans, put big wheels on them and then use a drainpipe for an exhaust system. The exact same ones that wake me up at midnight on a Tuesday with wheel spins and screaming engines somehow thinking I'll enjoy it just as much as they do. Interestingly they have the exact same problems trying to find insurance as EV converters, so don't be scared to ask them when you're out & about.

Alternatively you could try logging into some modified car club websites in your country or state and asking online.

What happens if I get stuck and need help?

There's no need to panic! If you come across something that's not answered in the ebook then you can contact me by opening a support ticket.

It's easy:

- 1: Simply click here: <http://www.evsecrets.com/support/>
- 2: Create a *support ticket* at that page.
- 3: *Then relax - I'll get back to you ASAP!*

Thank you for reading this ebook.
Good luck with your conversion 😊

Gavin Shoebridge

Disclaimer: As you'd expect, with any book there's always a little bit of small print! It's the usual: I wish you the best of luck with your conversion but this book is only intended as a guide and not as a definitive rulebook. Ask a professional if in doubt and always follow instructions sent by your component manufacturer. Have fun!

Copyright stuff: All photos and diagrams in this ebook were used with permission of their creators and owners to which I'm very grateful. I'd like to thank the community at www.diyelectriccar.com for their input and photos. I'd like to also thank the many people that took part in the survey for this ebook which helped me tailor this publication specifically towards EV newbies, to help answer the questions first time converters have and guide them through a typical first-time conversion.