



## FUNDAMENTALS OF ELECTROCHEMICAL CAPACITOR DESIGN AND OPERATION

by John R. Miller and Patrice Simon

Capacitors store electrical charge. Because the charge is stored physically, with no chemical or phase changes taking place, the process is highly reversible and the discharge-charge cycle can be repeated over and over again, virtually without limit. Electrochemical capacitors (ECs), variously referred to by manufacturers in promotional literature as “supercapacitors” or “ultracapacitors,” store electrical charge in an electric double layer at the interface between a high-surface-area carbon electrode and a liquid electrolyte.<sup>1,2</sup> Consequently, they are also quite properly referred to as electric double layer capacitors.

A simple EC can be constructed by inserting two conductors in a beaker containing an electrolyte, for example, two carbon rods in salt water (Fig. 1). Initially there is no measurable voltage between the two rods, but when the switch is closed

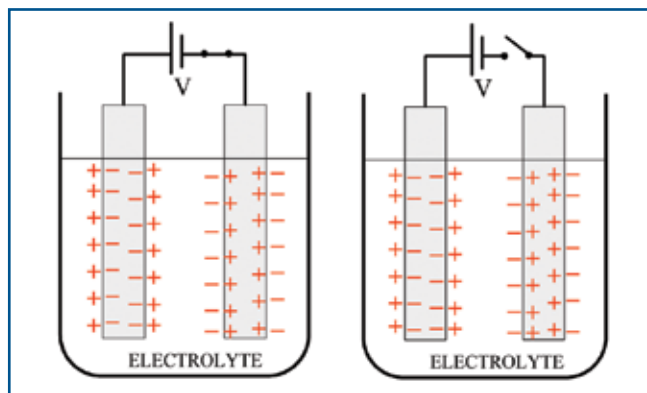

**FIG. 1.** Electric double layer capacitor constructed by inserting two electrodes in a beaker and applying a voltage. The voltage persists after the switch is opened (right), creating two series-connected capacitors. Charges in the electric double layer are separated by only about 1 nm.

and current is caused to flow from one rod to the other by a battery, charge separation is naturally created at each liquid-solid interface. This effectively creates two capacitors that are series-connected by the electrolyte. Voltage persists after the switch is opened—energy has been stored. In this state, solvated ions in the electrolyte are attracted to the solid surface by an equal but opposite charge in the solid. These two parallel regions of charge form the source of the term “double layer.” Charge separation is measured in molecular dimensions (*i.e.*, few angstroms), and the surface area is measured in thousands of square meters per gram of electrode material, creating 5 kF capacitors that can be hand-held.

The very feature of an electrochemical capacitor that makes such high capacitances possible, namely the highly porous high-surface-area electrodes, is also the reason for the relatively slow response of these devices compared to conventional capacitors. To illustrate the reason, Fig. 2 shows an idealistic representation of a cross-section of a pore in a nanoporous carbon material, where it is shown as a cylinder filled with electrolyte and in which an electric double layer covers the interior wall surface of the pore.<sup>3</sup> Electrical connections to the stored charge are made through the solid carbon surrounding the pore and through the electrolyte from the mouth of the

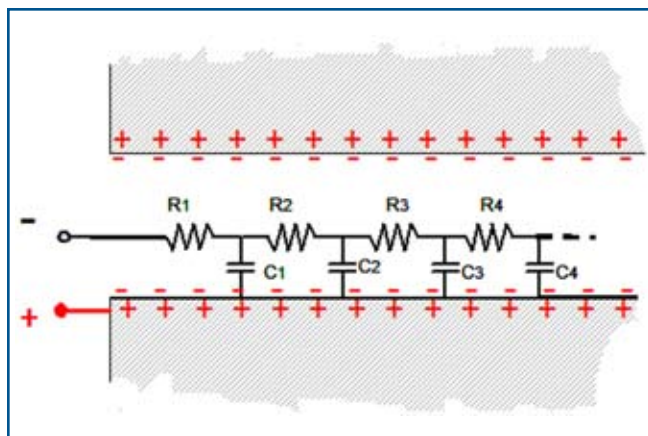

**FIG. 2.** Idealistic representation of an electrolyte-filled right-cylindrical nanopore in a carbon electrode of an electrochemical capacitor showing the distributed resistance from the electrolyte and distributed charge storage down the interior surface of the nanopore.

pore, electrolyte conductivity being much less than carbon conductivity. Charge stored near the pore mouth is accessible through a short path with small electrolyte resistance. In contrast, charge stored deeper within the pore must traverse a longer electrolyte path with a significantly higher series resistance. Thus, the overall response can be represented by a multiple-time-constant equivalent circuit model.<sup>4-6</sup> Irrespective of this behavior, the response time of an electrochemical capacitor in both charge and discharge operation is extremely short, about 1 second, as compared to batteries (minutes to tens of minutes).

The operating voltage of an electrochemical capacitor is limited by the breakdown potential of the electrolyte (typically 1 to 3 V per cell) and is generally much lower than that of conventional electrostatic and electrolytic capacitors. In many practical applications, therefore, electrochemical capacitor cells must be series-connected, similar to batteries, to meet operating voltage requirements. To illustrate the major differences between secondary (rechargeable) batteries and electrochemical capacitors, important fundamental properties of each are compared in Table I. The fundamental difference between batteries and electrochemical capacitors is that the former store energy in the bulk of chemical reactants capable of generating charge, whereas the latter store energy directly as surface charge. Battery discharge rate and therefore power performance is then limited by the reaction kinetics as well as the mass transport, while such limitations do not apply to electrochemical capacitors constructed with two activated carbon electrodes, thereby allowing exceptionally high power capability during both discharge and charge. Most batteries exhibit a relatively constant operating voltage because of the thermodynamics of the battery reactants; as a consequence it is often difficult to measure their state-of-charge (SOC) precisely. On the other hand, for a capacitor, its operating voltage changes linearly with time during constant current operation so that the SOC can be exactly pinpointed. Furthermore, the highly reversible electrostatic charge storage mechanism in ECs does not lead to any volume change like observed in batteries with

(continued on next page)

**Table 1. Comparison of properties of secondary batteries and electrochemical capacitors.**

Property	Battery	Electrochemical Capacitor
Storage mechanism	Chemical	Physical
Power limitation	Electrochemical reaction kinetics, active materials conductivity, mass transport	Electrolyte conductivity in separator and electrode pores
Energy limitation	Electrode mass (bulk)	Electrode surface area
Output voltage	Approximate constant value	Sloping value - state of charge known precisely
Charge rate	Reaction kinetics, mass transport	Very high, same as discharge rate
Cycle life limitations	Mechanical stability, chemical reversibility	Side reactions
Life limitation	Thermodynamic stability	Side reactions

electrochemical transformations of active masses. This volume change limits the cyclability of batteries generally to several hundred cycles whereas ECs have demonstrated from hundreds of thousands to many millions of full charge/discharge cycles.

Beside double layer capacitors, there is a class of energy storage materials that undergo electron transfer reactions yet behave in a capacitive manner. These materials store the energy using highly reversible surface redox (faradaic) reactions in addition to the electric double layer storage, thus defining pseudocapacitive storage.<sup>1</sup> Materials that exhibit pseudocapacitance range from conducting polymers to a variety of transition metal oxides.<sup>7-9</sup> The most famous is the RuO<sub>2</sub> pseudocapacitor that can reach above 800 F/g, very high volumetric and power densities, and exhibits excellent cycle life. On the downside, RuO<sub>2</sub> is a noble metal oxide and as such far too expensive for most commercial applications. Efforts to develop more practical pseudocapacitive materials are quite active at this time.

The earliest electrochemical capacitors introduced 30 years ago were symmetric designs (two identical electrodes) in aqueous electrolyte, H<sub>2</sub>SO<sub>4</sub> or KOH, which limited operating cell voltage to ~1.2 V/cell and nominal cell rating to ~0.9 V. In the second generation of electrochemical capacitors, the use of organic electrolyte—typically an ammonium salt dissolved in an organic solvent, such as propylene carbonate or acetonitrile—led to an increase of the rated cell voltage from about 0.9 V/cell to 2.3-2.7 V/cell. Spiral-wound or prismatic plate construction electrochemical capacitors using an organic electrolyte are the most popular type today.

The most recent electrochemical capacitor designs are asymmetric and comprised of two capacitors in series, one capacitor-like and the other a pseudocapacitor or battery-like, with varying electrode capacity ratios, depending on the application. The capacitor electrode is identical to those used in symmetric electrochemical capacitors. In contrast, the battery-like or pseudocapacitor electrode relies on highly-reversible redox (electron charge transfer) reactions. In this design, the capacity of the battery-like electrode is generally many times greater than the capacity of the double layer capacitor electrode, which is the basis for the name “asymmetric.” In comparing the two designs, both with the exact same carbon double layer charge storage electrode and electrolyte, the asymmetric design provides exactly

twice the capacitance of the symmetric design. This occurs because the electron-transfer electrode's potential is essentially fixed, with only the carbon electrode potential changing with charge. Also, the operating voltage of the asymmetric design is larger, due to the two electrodes having different rest potentials. Both of these factors contribute to a higher energy density than can be achieved with a symmetric design.

Several novel asymmetric electrochemical capacitor designs are under development<sup>10-12</sup> using a lithium ion intercalation electrode in an organic electrolyte at 3.8V<sup>10</sup> or a carbon electrode with a lead dioxide battery-like electrode using H<sub>2</sub>SO<sub>4</sub> as the electrolyte, operating at 2.1 V with the potential of being very low cost.<sup>11</sup> Each of these designs can provide high cycle-life due to the electrode capacity asymmetry. Considerable research emphasis is being given to asymmetric electrochemical capacitors today because of the very attractive performance features. ■

## About the Authors

**JOHN R. MILLER** is President of JME, Inc., a company he started in 1989 to serve the electrochemical capacitor (EC) industry by providing materials evaluations, capacitor design and testing services, reliability assessment, and system engineering. Dr. Miller has reported on many critical EC technology issues, taught ECS Short Courses on EC technology, chaired the Kilofarad International trade organization Standard's Committee for EC testing, and prepared EC test methods for the DOE. His present activities include EC reliability evaluations for heavy hybrid vehicles and the development of advanced ECs for emerging applications. He may be reached at [jmecapacitor@att.net](mailto:jmecapacitor@att.net).

**PATRICE SIMON** is a professor of materials science at the University Paul Sabatier in Toulouse, France. His research is focused on the synthesis and the characterization of nanostructured materials for electrochemical energy storage sources, and most particularly for electrochemical capacitors and Li-ion battery systems. He may be reached at [simon@chimie.ups-tlse.fr](mailto:simon@chimie.ups-tlse.fr).

## References

1. B. E. Conway, in “Electrochemical Supercapacitors: Scientific Fundamentals and Technological Applications,” Kluwer Academic/Plenum Publishers, New York, 1999.
2. J. Chmiola, G. Yushin, Y. Gogotsi, C. Portet, P. Simon, and P. L. Taberna, *Science*, **313**, 1760 (2006).
3. R. De Levie, *Electrochim. Acta*, **8**, 751 (1963).
4. J. R. Miller, Proceedings of the Second International Symposium on EDLC and Similar Energy Storage Sources, S. P. Wolsky and N. Marincic, Editors, Florida Educational Seminars, Boca Raton (1992).
5. J. R. Miller, Proceedings of the 8<sup>th</sup> International Symposium on EDLC and Similar Energy Storage Sources, S. P. Wolsky and N. Marincic, Editors, Florida Educational Seminars, Boca Raton (1998).
6. P. L. Taberna, P. Simon, and J. F. Fauvarque, *J. Electrochem. Soc.*, **150**, A292 (2003).
7. I. D. Raistrick and R. J. Sherman, *Proceedings of the Symposium on Materials for Energy Conversion and Storage*, S. Srinivasan, S. Wagner, and H. Wroblowa, Editors, PV 87-12, The Electrochemical Society Proceedings Series, Pennington, NJ (1987).
8. M. Mastragostino, K. Arbizzani, and F. Soavi, *Solid State Ionics*, **148**, 493 (2002).
9. M. S. Hong, S. H. Lee, and S. W. Kim, *Electrochem. Solid-State Lett.*, **5**, A227 (2002).
10. T. Morimoto, Proceedings of the International Conference on Advanced Capacitors, May 28-30, 2007, Kyoto, Japan.
11. S. A. Kazaryan, S. N. Razumov, S. V. Litvinenko, G. G. Kharisov, and V. I. Kogan, *J. Electrochem. Soc.*, **153**, A1655 (2006).
12. A. Balducci, W. A. Henderson, M. Mastragostino, S. Passerini, P. Simon, and F. Soavi, *Electrochim. Acta*, **50**, 2233 (2005).