



# Pulse Circuits

**tutorialspoint**

S I M P L Y E A S Y L E A R N I N G

[www.tutorialspoint.com](http://www.tutorialspoint.com)



<https://www.facebook.com/tutorialspointindia>



<https://twitter.com/tutorialspoint>

## About the Tutorial

---

In this tutorial, we will discuss all the important circuits that are related to pulse signals. In addition, we will also cover the circuits that generate and work with pulse signals.

## Audience

---

A reader who is interested in the basics of pulse and sweep related circuits and who aspires to have an idea regarding the generation and applications of pulse and sweep signals, can go ahead with this tutorial.

## Prerequisites

---

We assume that the readers have prior knowledge on the fundamental concepts of Basic Electronic Circuits and the behavior of different electronic components.

For reference, the readers can browse through our ELECTRONIC CIRCUITS tutorial at [https://www.tutorialspoint.com/electronic\\_circuits/index.htm](https://www.tutorialspoint.com/electronic_circuits/index.htm).

## Disclaimer & Copyright

---

© Copyright 2017 by Tutorials Point (I) Pvt. Ltd.

All the content and graphics published in this e-book are the property of Tutorials Point (I) Pvt. Ltd. The user of this e-book is prohibited to reuse, retain, copy, distribute or republish any contents or a part of contents of this e-book in any manner without written consent of the publisher.

We strive to update the contents of our website and tutorials as timely and as precisely as possible, however, the contents may contain inaccuracies or errors. Tutorials Point (I) Pvt. Ltd. provides no guarantee regarding the accuracy, timeliness or completeness of our website or its contents including this tutorial. If you discover any errors on our website or in this tutorial, please notify us at [contact@tutorialspoint.com](mailto:contact@tutorialspoint.com)

## Table of Contents

---

About the Tutorial .....	i
Audience .....	i
Prerequisites .....	i
Disclaimer & Copyright .....	i
Table of Contents .....	ii
<b>PULSE CIRCUITS – BASICS.....</b>	<b>1</b>
<b>1. Pulse Circuits – Signal .....</b>	<b>2</b>
Electronic Signal.....	2
Pulse Signal .....	2
Terms Related to Pulse signals .....	3
<b>2. Pulse Circuits – Switch .....</b>	<b>5</b>
Mechanical Switches .....	5
Relays.....	6
Electronic Switch .....	9
<b>3. Pulse Circuits – Transistor as a Switch .....</b>	<b>11</b>
ON & OFF States of a Transistor .....	11
Practical Considerations .....	13
Switching Action of a Transistor .....	13
Switching Times .....	14
<b>MULTIVIBRATORS .....</b>	<b>16</b>
<b>4. Pulse Circuits – Multivibrator (Overview) .....</b>	<b>17</b>
What is a Multivibrator? .....	17
Types of Multivibrators.....	17
<b>5. Pulse Circuits – Astable Multivibrator .....</b>	<b>19</b>
Construction of Astable Multivibrator .....	19
Operation of Astable Multivibrator .....	19
<b>6. Pulse Circuits – Monostable Multivibrator .....</b>	<b>22</b>
Construction of Monostable Multivibrator .....	22
Operation of Monostable Multivibrator .....	23
<b>7. Pulse Circuits – Bistable Multivibrator.....</b>	<b>25</b>
Construction of Bistable Multivibrator .....	25
Operation of Bistable Multivibrator .....	26
Fixed-bias Binary.....	28
Schmitt Trigger .....	28

<b>TIME BASE GENERATORS</b> .....	<b>31</b>
<b>8. Pulse Circuits – Time Base Generators (Overview)</b> .....	<b>32</b>
What is a Time Base Generator? .....	32
Features of a Time Base Signal .....	32
Errors of Sweep Signals.....	33
<b>9. Pulse Circuits – Types of Time Base Generators</b> .....	<b>36</b>
Voltage Time base Generator .....	36
Current Time base Generator .....	37
<b>10. Pulse Circuits – Bootstrap Time Base Generator</b> .....	<b>39</b>
Construction of Bootstrap Time Base Generator .....	39
Operation of Bootstrap Time Base Generator.....	39
<b>11. Pulse Circuits – Miller Sweep Generator</b> .....	<b>41</b>
Construction of Miller Sweep Generator.....	41
Operation of Miller Sweep Generator .....	42
<b>SWEEP CIRCUITS</b> .....	<b>43</b>
<b>12. Pulse Circuits – Unijunction Transistor</b> .....	<b>44</b>
Construction of UJT .....	44
Working of UJT .....	44
V-I Characteristics of UJT .....	46
<b>13. Pulse Circuits – UJT as Relaxation Oscillator</b> .....	<b>48</b>
<b>14. Pulse Circuits – Synchronization</b> .....	<b>50</b>
Types of Synchronization.....	50
Synchronization in Relaxation Devices .....	50
Frequency Division in Sweep Circuits .....	51
<b>15. Pulse Circuits – Blocking Oscillators</b> .....	<b>53</b>
Blocking Oscillator .....	53
Monostable Blocking Oscillator .....	54
Astable Blocking Oscillator .....	56
<b>SAMPLING GATES</b> .....	<b>59</b>
<b>16. Pulse Circuits – Sampling Gates</b> .....	<b>60</b>
Sampling Gates .....	60
Types of Switches Used .....	61
<b>17. Pulse Circuits – Unidirectional Sampling Gate</b> .....	<b>62</b>
Special Cases.....	64
Effect of RC on Control voltage.....	66
Pros and Cons of Unidirectional Sampling Gates.....	67

<b>18. Pulse Circuits – Unidirectional with More Inputs.....</b>	<b>68</b>
Pedestal Reduction .....	69
<b>19. Pulse Circuits – Bidirectional Sampling Gates .....</b>	<b>71</b>
Bidirectional Sampling Gates using Transistors .....	71
Four Diode Bidirectional Sampling Gate.....	72
Applications of Sampling Gates .....	73
Sampling Scope.....	73

# Pulse Circuits – Basics

# 1. Pulse Circuits – Signal

A **Signal** not only carries information but it also represents the condition of the circuit. The functioning of any circuit can be studied by the signal it produces. Hence, we will start this tutorial with a brief introduction to signals.

## Electronic Signal

---

An electronic signal is similar to a normal signal we come across, which indicates something or which informs about something. The graphical representation of an electronic signal gives information regarding the periodical changes in the parameters such as amplitude or phase of the signal. It also provides information regarding the voltage, frequency, time period, etc.

This representation brings some shape to the information conveyed or to the signal received. Such a shape of the signal when formed according to a certain variation, can be given different names, such as sinusoidal signal, triangular signal, saw tooth signal and square wave signal etc.

These signals are mainly of two types named as Unidirectional and Bidirectional signals.

- **Unidirectional Signal** – The signal when flows only in one direction, which is either positive or negative, such a signal is termed as Unidirectional signal.  
**Example:** Pulse signal.
- **Bidirectional Signal** – The signal when alters in both positive and negative directions crossing the zero point, such a signal is termed as a Bidirectional signal.  
**Example:** Sinusoidal signal.

In this chapter, we are going to discuss pulse signals and their characteristic features.

## Pulse Signal

---

A Pulse shape is formed by a rapid or sudden transient change from a baseline value to a higher or lower level value, which returns to the same baseline value after a certain time period. Such a signal can be termed as Pulse Signal.

The following illustration shows a series of pulses.

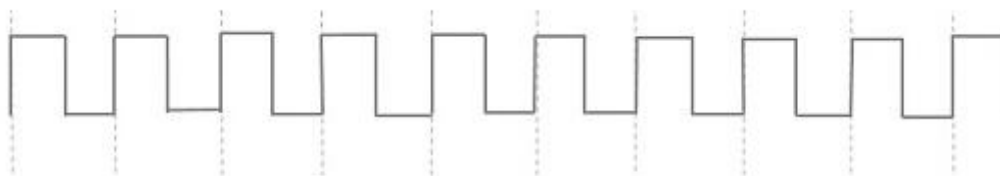

A Series of Pulse train

A Pulse signal is a unidirectional, non-sinusoidal signal which is similar to a square signal but it is not symmetrical like a square wave. A series of continuous pulse signals is simply called as a pulse train. A train of pulses indicate a sudden high level and a sudden low level transition from a baseline level which can be understood as ON/OFF respectively.

Hence a pulse signal indicates ON & OFF of the signal. If an electric switch is given a pulse input, it gets ON/OFF according to the pulse signal given. These switches which produce the pulse signals can be discussed later.

## Terms Related to Pulse signals

There are few terms related to pulse signals which one should know. These can be understood with the help of the following figure.

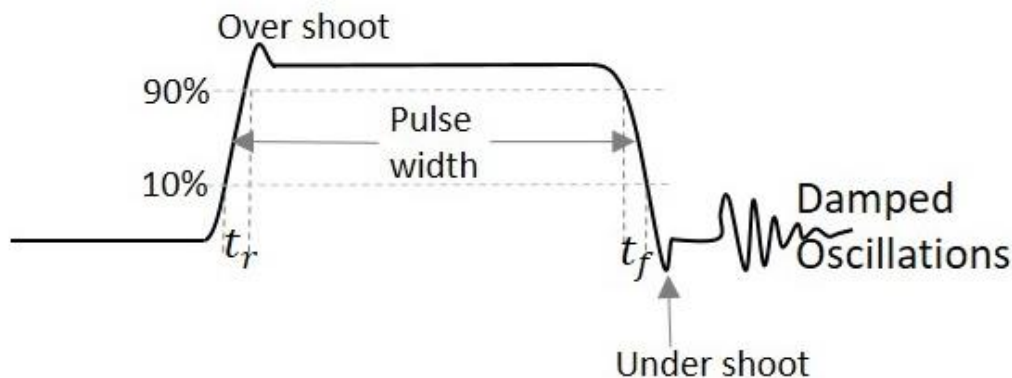

From the above figure,

- **Pulse width:** Length of the pulse
- **Period of a waveform:** Measurement from any point on one cycle to the same point on next cycle
- **Duty cycle:** Ratio of the pulse width to the period
- **Rise time:** Time it takes to rise from 10% to 90% of its maximum amplitude.
- **Fall time:** Time signal takes to fall from 90% to 10% of its maximum amplitude.
- **Overshoot:** Said to be occurred when leading edge of a waveform exceeds its normal maximum value.
- **Undershoot:** Said to be occurred when trailing edge of a waveform exceeds its normal maximum value.
- **Ringing:** Both undershoot and overshoot are followed by damped oscillations known as ringing.



The damped oscillations are the signal variations that indicate the decreasing amplitude and frequency of the signal which are of no use and unwanted. These oscillations are simple disturbances known as **ringing**.

In the next chapter, we will explain the concept of switching in electronics done using BJTs. We had already discussed switching using diodes in our ELECTRONIC CIRCUITS tutorial. Please refer:

## 2. Pulse Circuits – Switch

A Switch is a device that **makes** or **breaks** a circuit or a contact. As well, it can convert an analog data into digital data. The main requirements of a switch to be efficient are to be quick and to switch without sparking. The essential parts are a switch and its associated circuitry.

There are three **types of Switches**. They are:

- Mechanical switches
- Electromechanical switches or Relays
- Electronic switches

### Mechanical Switches

---

The Mechanical Switches are the older type switches, which we previously used. But they had been replaced by Electro-mechanical switches and later on by electronic switches also in a few applications, so as to get over the disadvantages of the former.

The drawbacks of Mechanical Switches are as follows:

- They have high inertia which limits the speed of operation.
- They produce sparks while breaking the contact.
- Switch contacts are made heavy to carry larger currents.

The mechanical switches look as in the figure below.

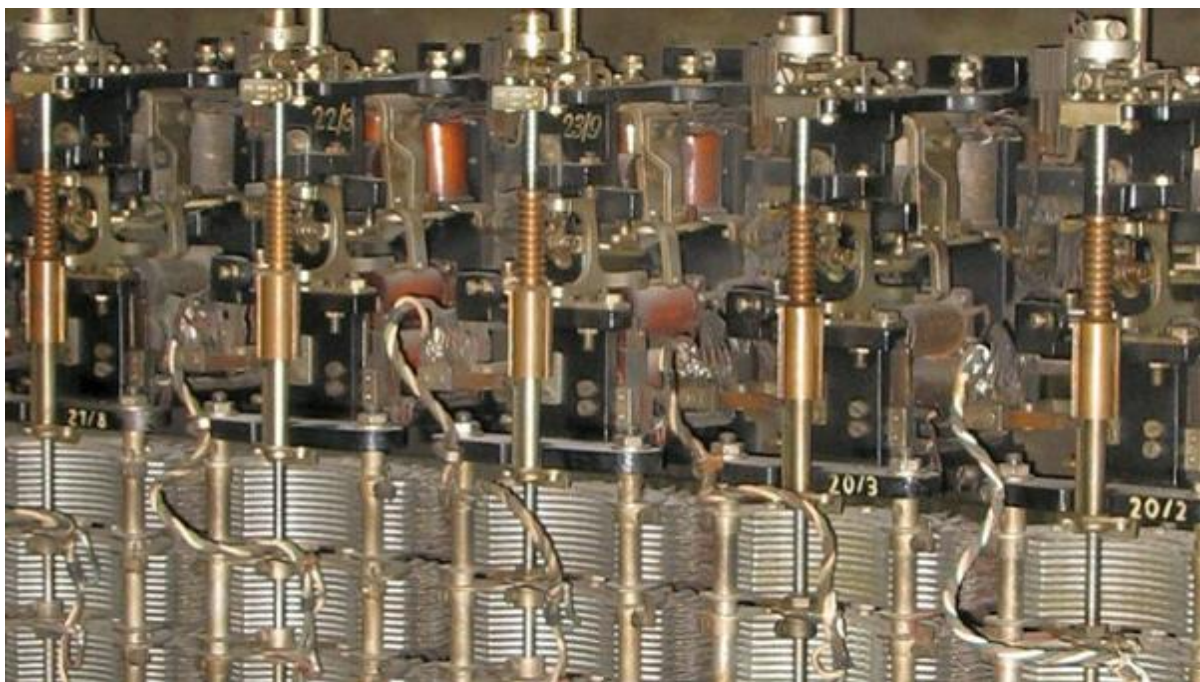

These mechanical switches were replaced by electro-mechanical switches or relays that have good speed of operation and reduce sparking.

## Relays

Electromechanical switches are also called as **Relays**. These switches are partially mechanical and partially electronic or electrical. These are greater in size than electronic switches and lesser in size than mechanical switches.

### Construction of a Relay

A Relay is made such that the making of contact supplies power to the load. In the external circuit, we have load power supply for the load and coil power supply for controlling the relay operation. Internally, a lever is connected to the iron yoke with a hard spring to hold the lever up. A Solenoid is connected to the yoke with an operating coil wound around it. This coil is connected with the coil power supply as mentioned.

The figure below explains the construction and working of a Relay.

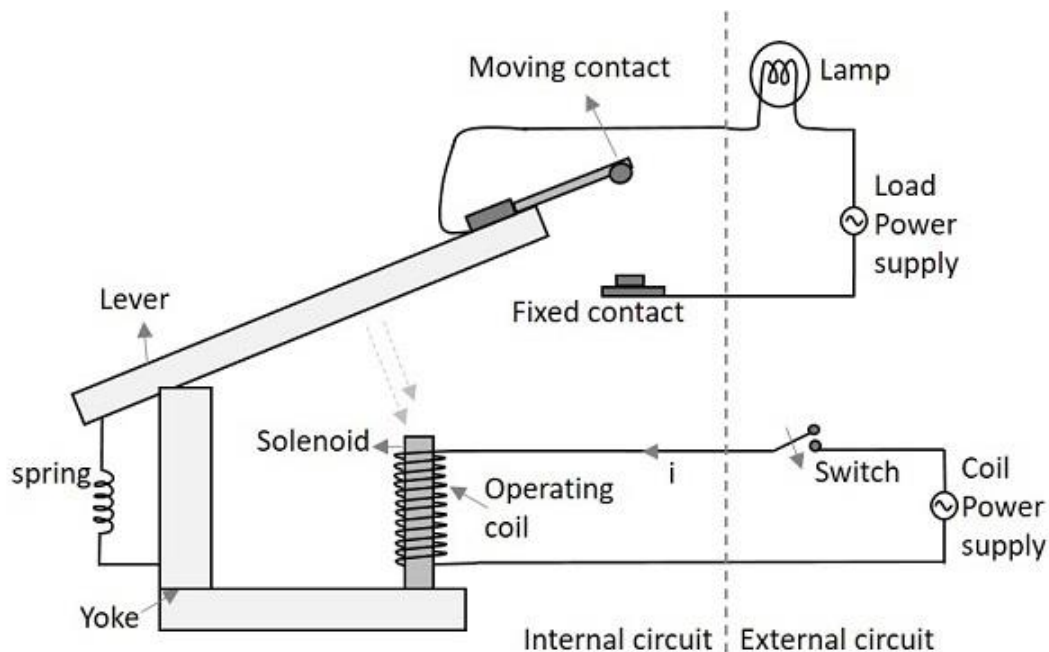

Working of a Relay

### Working of a Relay

When the Switch is closed, an electrical path is established which energizes the solenoid. The lever is connected by a heavy spring which pulls up the lever and holds. The solenoid when gets energized, pulls the lever towards it, against the pulling force of the spring. When the lever gets pulled, the moving contact meets the fixed contact in order to connect

the circuit. Thus the circuit connection is ON or established and the lamp glows indicating this.

When the switch is made OFF, the solenoid doesn't get any current and gets de-energized. This leaves the lever without any attraction towards the solenoid. The spring pulls the lever up, which breaks the contact. Thus the circuit connection gets switched OFF.

The figure below shows how a practical relay looks like.

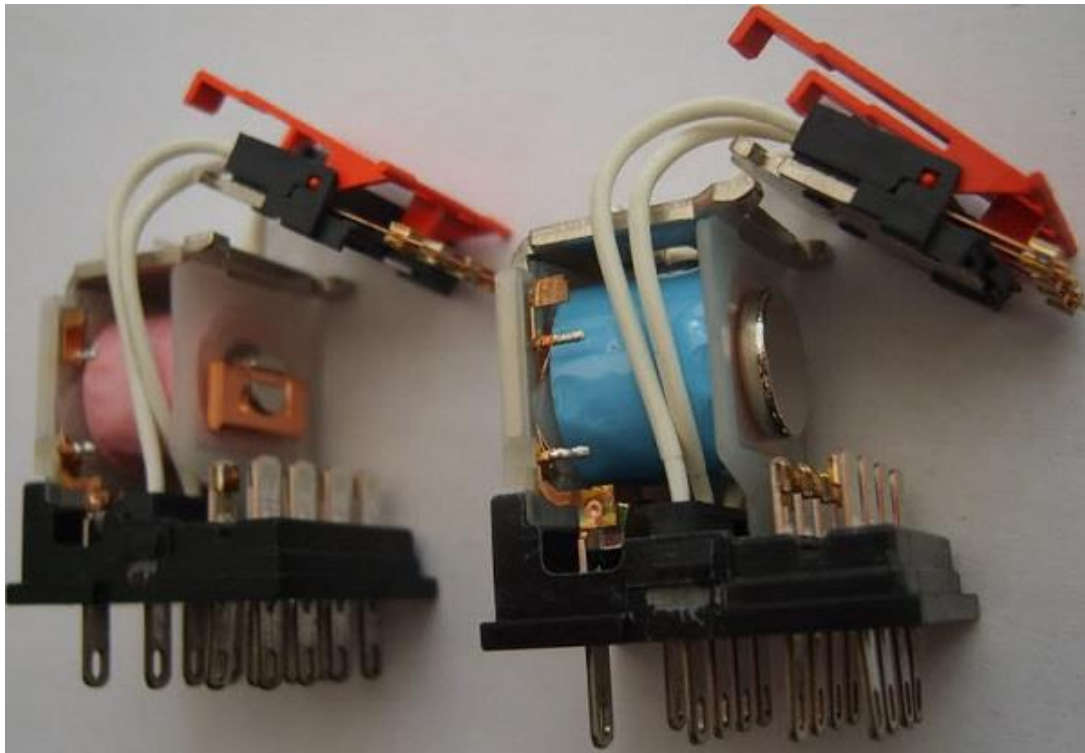

Let us now have a look at the advantages and disadvantages of an Electro-magnetic switch.

### Advantages

- A relay consumes less energy, even to handle a large power at the load.
- The operator can be at larger distance, even to handle high voltages.
- No Sparking while turning ON or OFF.

### Disadvantages

- Slow in operation
- Parts are prone to wear and tear

## Types of Latches in Relays

There are many kinds of relays depending upon their mode of operation such as Electromagnetic relay, solid-state relay, thermal relay, hybrid relay, reed relay etc.

The relay makes the connection with the help of a latch, as shown in the following figure.

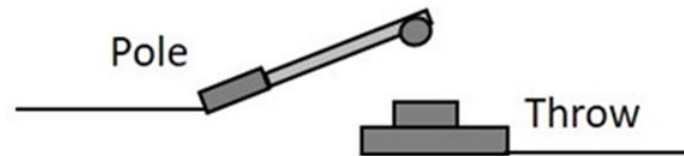

Structure of a latch

There are four types of latch connections in relays. They are:

- **Single Pole Single Throw (SPST)** – This latch has a single pole and is thrown onto a single throw to make a connection.
- **Single Pole Double Throw (SPDT)** – This latch has a single pole and double throw to make a connection. It has a choice to make connection with two different circuits for which two throws were connected.
- **Double Pole Single Throw (DPST)** – This latch has a double pole and single throw to make a connection. Any of the two circuits can choose to make the connection with the circuit available at the single throw.
- **Double Pole Double Throw (DPDT)** – This latch has a double pole and is thrown onto double throw to make two connections at the same time.

The following figure shows the diagrammatic view of all the four types of latch connections.

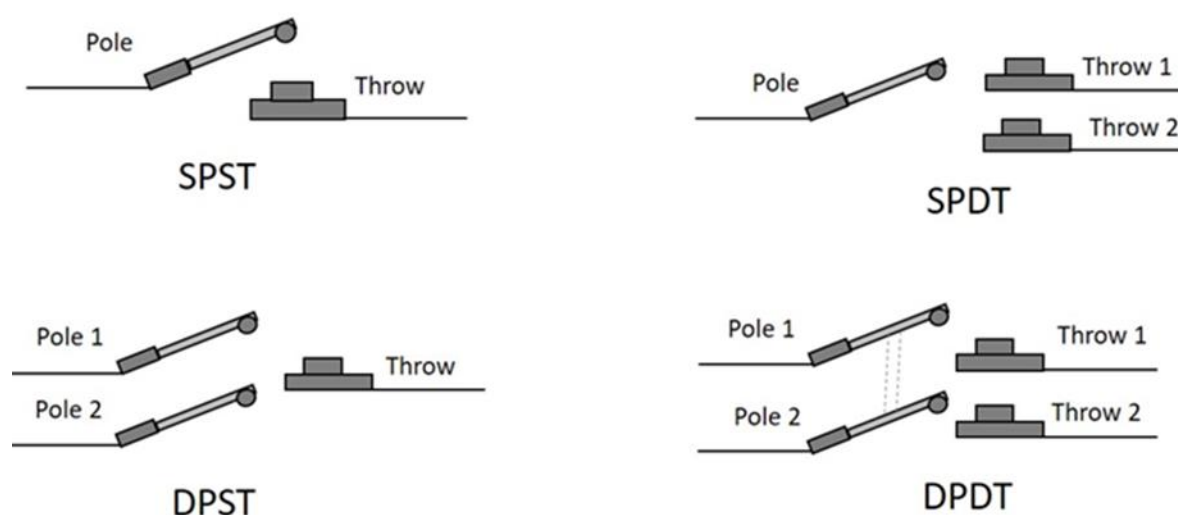

## Electronic Switch

The next kind of switch to be discussed is the Electronic Switch. As mentioned earlier, transistor is the mostly used electronic switch for its **high operating speed** and **absence of sparking**.

The following image shows a practical electronic circuit built to make transistor work as a switch.

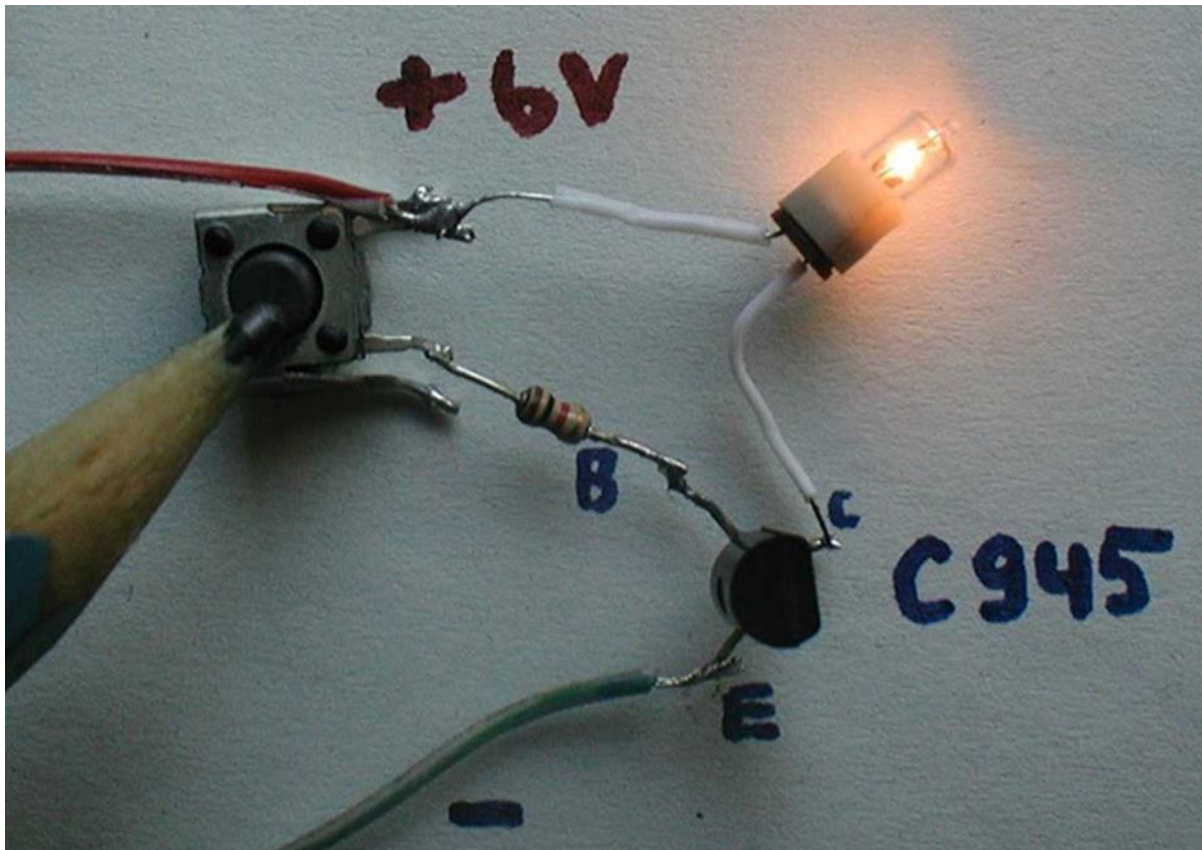

A Transistor works as a switch in ON condition, when it is operated in saturation region. It works as a switch in OFF condition, when it is operated in cut off region. It works as an amplifier in linear region, which lies between transistor and cut off. To have an idea regarding these regions of operation, refer to the transistors chapter from BASIC ELECTRONICS tutorial.

When the external conditions are so robust and high temperatures prevail, then a simple and normal transistor would not do. A special device named as **Silicon Control Rectifier**, simply **SCR** is used for such purposes. This will be discussed in detail, in the POWER ELECTRONICS tutorial.

## Advantages of an Electronic Switch

There are many advantages of an Electronic switch such as

- Smaller in size
- Lighter in weight
- Sparkles operation
- No moving parts
- Less prone to wear and tear
- Noise less operation
- Faster operation
- Cheaper than other switches
- Less maintenance
- Trouble-free service because of solid-state

A **transistor** is a simple electronic switch that has high operating speed. It is a solid state device and the contacts are all simple and hence the sparking is avoided while in operation. We will discuss the stages of switching operation in a transistor in the next chapter.

### 3. Pulse Circuits – Transistor as a Switch

A **transistor** is used as an electronic switch by driving it either in **saturation** or in **cut off**. The region between these two is the linear region. A transistor works as a linear amplifier in this region. The **Saturation** and **Cut off** states are important consideration in this regard.

#### ON & OFF States of a Transistor

---

There are two main regions in the operation of a transistor which we can consider as **ON** and **OFF** states. They are **saturation** and **cut off** states. Let us have a look at the behavior of a transistor in those two states.

#### Operation in Cut-off condition

The following figure shows a transistor in cut-off region.

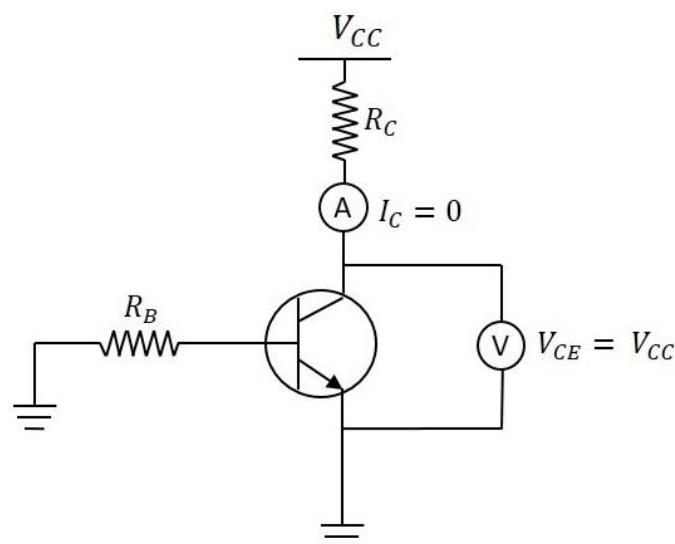

When the base of the transistor is given negative, the transistor goes to cut off state. There is no collector current. Hence  $I_C = 0$ .

The voltage  $V_{CC}$  applied at the collector, appears across the collector resistor  $R_C$ . Therefore,

$$V_{CE} = V_{CC}$$



## Operation in Saturation region

The following figure shows a transistor in saturation region.

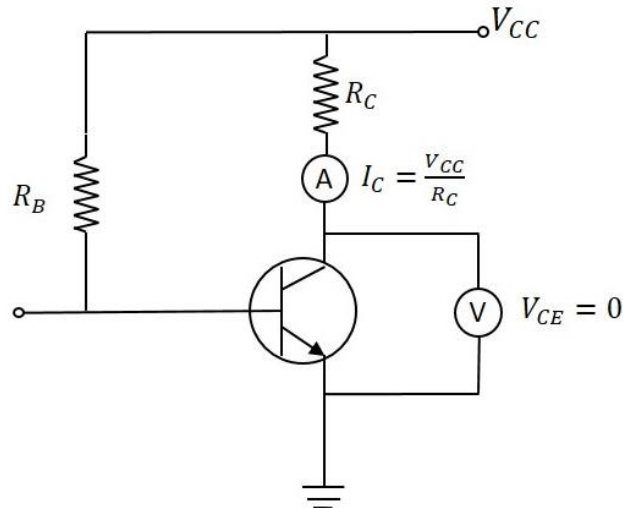

When the base voltage is positive and transistor goes into saturation,  $I_C$  flows through  $R_C$ . Then  $V_{CC}$  drops across  $R_C$ . The output will be zero.

$$I_C = I_{C(sat)} = \frac{V_{CC}}{R_C} \quad \text{and} \quad V_{CE} = 0$$

Actually, this is the ideal condition. Practically, some leakage current flows. Hence we can understand that a transistor works as a switch when driven into saturation and cut off regions by applying positive and negative voltages to the base.

The following figure gives a better explanation.

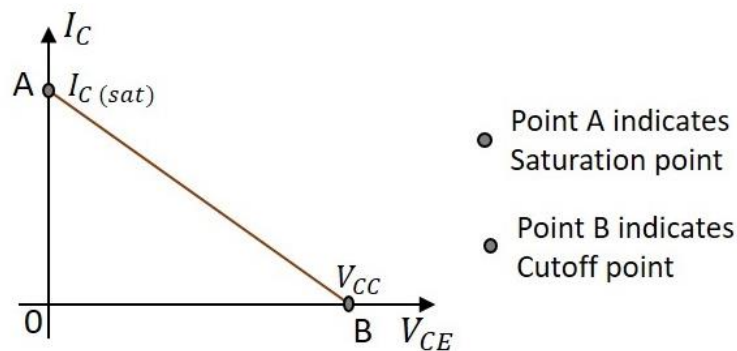

Graph indicating DC Load line

Observe the dc load line that connects the  $I_C$  and  $V_{CC}$ . If the transistor is driven into saturation,  $I_C$  flows completely and  $V_{CE} = 0$  which is indicated by the point A.

If the transistor is driven into cut off,  $I_C$  will be zero and  $V_{CE} = V_{CC}$  which is indicated by the point B. the line joining the saturation point A and cut off B is called as **Load line**. As the voltage applied here is dc, it is called as **DC Load line**.

## Practical Considerations

---

Though the above-mentioned conditions are all convincing, there are a few practical limitations for such results to occur.

### During the Cut off state

An ideal transistor has  $V_{CE} = V_{CC}$  and  $I_C = 0$ .

But in practice, a smaller leakage current flows through the collector.

Hence  $I_C$  will be a few  $\mu\text{A}$ .

This is called as **Collector Leakage Current** which is of course, negligible.

### During the Saturation State

An ideal transistor has  $V_{CE} = 0$  and  $I_C = I_{C(sat)}$ .

But in practice,  $V_{CE}$  decreases to some value called **knee voltage**.

When  $V_{CE}$  decreases more than knee voltage,  $\beta$  decreases sharply.

As  $I_C = \beta I_B$  this decreases the collector current.

Hence that maximum current  $I_C$  which maintains  $V_{CE}$  at knee voltage, is known as **Saturation Collector Current**.

$$\text{Saturation Collector Current} = I_{C(sat)} = \frac{V_{CC} - V_{knee}}{R_C}$$

A Transistor which is fabricated only to make it work for switching purposes is called as **Switching Transistor**. This works either in Saturation or in Cut off region. While in saturation state, the **collector saturation current** flows through the load and while in cut off state, the **collector leakage current** flows through the load.

## Switching Action of a Transistor

---

A Transistor has three regions of operation. To understand the efficiency of operation, the practical losses are to be considered. So let us try to get an idea on how efficiently a transistor works as a switch.

### During Cut off (OFF) state

$$\text{The Base current } I_B = 0$$

$$\text{The Collector current } I_C = I_{CEO} (\text{collector leakage current})$$

$$\text{Power Loss} = \text{Output Voltage} \times \text{Output Current}$$

$$= V_{CC} \times I_{CEO}$$

As  $I_{CEO}$  is very small and  $V_{CC}$  is also low, the loss will be of very low value. Hence, a transistor works as an efficient switch in OFF state.

### During Saturation (ON) state

As discussed earlier,

$$I_{C(sat)} = \frac{V_{CC} - V_{knee}}{R_C}$$

The output voltage is  $V_{knee}$ .

$$\begin{aligned} \text{Power loss} &= \text{Output voltage} \times \text{Output Current} \\ &= V_{knee} \times I_{C(sat)} \end{aligned}$$

As  $V_{knee}$  will be of small value, the loss is low. Hence, a transistor works as an efficient switch in ON state.

### During Active region

The transistor lies between ON & OFF states. The transistor operates as a linear amplifier where small changes in input current cause large changes in the output current ( $\Delta I_C$ ).

End of ebook preview

If you liked what you saw...

Buy it from our store @ <https://store.tutorialspoint.com>