

# A First Course in Complex Analysis

Version 1.31

MATTHIAS BECK, GERALD MARCHESI,  
DENNIS PIXTON, LUCAS SABALKA

Department of Mathematics  
San Francisco State University  
San Francisco, CA 94132

`beck@math.sfsu.edu`

Department of Mathematical Sciences  
Binghamton University (SUNY)  
Binghamton, NY 13902-6000

`marchesi@math.binghamton.edu`

`dennis@math.binghamton.edu`

`sabalka@math.binghamton.edu`

Copyright 2002–2011 by the authors. All rights reserved. The most current version of this book is available at the websites

<http://www.math.binghamton.edu/dennis/complex.pdf>

<http://math.sfsu.edu/beck/complex.html>.

This book may be freely reproduced and distributed, provided that it is reproduced in its entirety from the most recent version. This book may not be altered in any way, except for changes in format required for printing or other distribution, without the permission of the authors.

These are the lecture notes of a one-semester undergraduate course which we have taught several times at Binghamton University (SUNY) and San Francisco State University. For many of our students, complex analysis is their first rigorous analysis (if not mathematics) class they take, and these notes reflect this very much. We tried to rely on as few concepts from real analysis as possible. In particular, series and sequences are treated “from scratch.” This also has the (maybe disadvantageous) consequence that power series are introduced very late in the course.

We thank our students who made many suggestions for and found errors in the text. Special thanks go to Joshua Palmatier, Collin Bleak and Sharma Pallekonda at Binghamton University (SUNY) for comments after teaching from this book.

# Contents

<b>1</b>	<b>Complex Numbers</b>	<b>1</b>
1.0	Introduction . . . . .	1
1.1	Definitions and Algebraic Properties . . . . .	1
1.2	From Algebra to Geometry and Back . . . . .	3
1.3	Geometric Properties . . . . .	6
1.4	Elementary Topology of the Plane . . . . .	8
1.5	Theorems from Calculus . . . . .	10
	Exercises . . . . .	11
<b>2</b>	<b>Differentiation</b>	<b>15</b>
2.1	First Steps . . . . .	15
2.2	Differentiability and Holomorphicity . . . . .	17
2.3	Constant Functions . . . . .	19
2.4	The Cauchy–Riemann Equations . . . . .	20
	Exercises . . . . .	23
<b>3</b>	<b>Examples of Functions</b>	<b>26</b>
3.1	Möbius Transformations . . . . .	26
3.2	Infinity and the Cross Ratio . . . . .	29
3.3	Stereographic Projection . . . . .	32
3.4	Exponential and Trigonometric Functions . . . . .	34
3.5	The Logarithm and Complex Exponentials . . . . .	37
	Exercises . . . . .	39
<b>4</b>	<b>Integration</b>	<b>44</b>
4.1	Definition and Basic Properties . . . . .	44
4.2	Cauchy’s Theorem . . . . .	47
4.3	Cauchy’s Integral Formula . . . . .	49
	Exercises . . . . .	51
<b>5</b>	<b>Consequences of Cauchy’s Theorem</b>	<b>55</b>
5.1	Extensions of Cauchy’s Formula . . . . .	55
5.2	Taking Cauchy’s Formula to the Limit . . . . .	57
5.3	Antiderivatives . . . . .	60
	Exercises . . . . .	62

<b>6</b>	<b>Harmonic Functions</b>	<b>65</b>
6.1	Definition and Basic Properties . . . . .	65
6.2	Mean-Value and Maximum/Minimum Principle . . . . .	67
	Exercises . . . . .	69
<b>7</b>	<b>Power Series</b>	<b>70</b>
7.1	Sequences and Completeness . . . . .	70
7.2	Series . . . . .	72
7.3	Sequences and Series of Functions . . . . .	75
7.4	Region of Convergence . . . . .	78
	Exercises . . . . .	82
<b>8</b>	<b>Taylor and Laurent Series</b>	<b>86</b>
8.1	Power Series and Holomorphic Functions . . . . .	86
8.2	Classification of Zeros and the Identity Principle . . . . .	89
8.3	Laurent Series . . . . .	91
	Exercises . . . . .	94
<b>9</b>	<b>Isolated Singularities and the Residue Theorem</b>	<b>97</b>
9.1	Classification of Singularities . . . . .	97
9.2	Residues . . . . .	101
9.3	Argument Principle and Rouché's Theorem . . . . .	103
	Exercises . . . . .	105
<b>10</b>	<b>Discrete Applications of the Residue Theorem</b>	<b>108</b>
10.1	Infinite Sums . . . . .	108
10.2	Binomial Coefficients . . . . .	109
10.3	Fibonacci Numbers . . . . .	109
10.4	The 'Coin-Exchange Problem' . . . . .	110
10.5	Dedekind sums . . . . .	111
	<b>Solutions to Selected Exercises</b>	<b>113</b>

# Chapter 1

## Complex Numbers

*Die ganzen Zahlen hat der liebe Gott geschaffen, alles andere ist Menschenwerk.  
(God created the integers, everything else is made by humans.)*

Leopold Kronecker (1823–1891)

### 1.0 Introduction

The real numbers have many nice properties. There are operations such as addition, subtraction, multiplication as well as division by any real number except zero. There are useful laws that govern these operations such as the commutative and distributive laws. You can also take limits and do calculus. But you cannot take the square root of  $-1$ . Equivalently, you cannot find a root of the equation

$$x^2 + 1 = 0. \tag{1.1}$$

Most of you have heard that there is a “new” number  $i$  that is a root of the Equation (1.1). That is,  $i^2 + 1 = 0$  or  $i^2 = -1$ . We will show that when the real numbers are enlarged to a new system called the complex numbers that includes  $i$ , not only do we gain a number with interesting properties, but we do not lose any of the nice properties that we had before.

Specifically, the complex numbers, like the real numbers, will have the operations of addition, subtraction, multiplication as well as division by any complex number except zero. These operations will follow all the laws that we are used to such as the commutative and distributive laws. We will also be able to take limits and do calculus. And, there will be a root of Equation (1.1).

In the next section we show exactly how the complex numbers are set up and in the rest of this chapter we will explore the properties of the complex numbers. These properties will be both algebraic properties (such as the commutative and distributive properties mentioned already) and also geometric properties. You will see, for example, that multiplication can be described geometrically. In the rest of the book, the calculus of complex numbers will be built on the properties that we develop in this chapter.

### 1.1 Definitions and Algebraic Properties

There are many equivalent ways to think about a complex number, each of which is useful in its own right. In this section, we begin with the formal definition of a complex number. We then

interpret this formal definition into more useful and easier to work with algebraic language. Then, in the next section, we will see three more ways of thinking about complex numbers.

The *complex numbers* can be defined as pairs of real numbers,

$$\mathbb{C} = \{(x, y) : x, y \in \mathbb{R}\},$$

equipped with the *addition*

$$(x, y) + (a, b) = (x + a, y + b)$$

and the *multiplication*

$$(x, y) \cdot (a, b) = (xa - yb, xb + ya).$$

One reason to believe that the definitions of these binary operations are “good” is that  $\mathbb{C}$  is an extension of  $\mathbb{R}$ , in the sense that the complex numbers of the form  $(x, 0)$  behave just like real numbers; that is,  $(x, 0) + (y, 0) = (x + y, 0)$  and  $(x, 0) \cdot (y, 0) = (x \cdot y, 0)$ . So we can think of the real numbers being embedded in  $\mathbb{C}$  as those complex numbers whose second coordinate is zero.

The following basic theorem states the algebraic structure that we established with our definitions. Its proof is straightforward but nevertheless a good exercise.

**Theorem 1.1.**  $(\mathbb{C}, +, \cdot)$  is a field; that is:

$$\forall (x, y), (a, b) \in \mathbb{C} : (x, y) + (a, b) \in \mathbb{C} \quad (1.2)$$

$$\forall (x, y), (a, b), (c, d) \in \mathbb{C} : ((x, y) + (a, b)) + (c, d) = (x, y) + ((a, b) + (c, d)) \quad (1.3)$$

$$\forall (x, y), (a, b) \in \mathbb{C} : (x, y) + (a, b) = (a, b) + (x, y) \quad (1.4)$$

$$\forall (x, y) \in \mathbb{C} : (x, y) + (0, 0) = (x, y) \quad (1.5)$$

$$\forall (x, y) \in \mathbb{C} : (x, y) + (-x, -y) = (0, 0) \quad (1.6)$$

$$\forall (x, y), (a, b), (c, d) \in \mathbb{C} : (x, y) \cdot ((a, b) + (c, d)) = (x, y) \cdot (a, b) + (x, y) \cdot (c, d) \quad (1.7)$$

$$\forall (x, y), (a, b) \in \mathbb{C} : (x, y) \cdot (a, b) \in \mathbb{C} \quad (1.8)$$

$$\forall (x, y), (a, b), (c, d) \in \mathbb{C} : ((x, y) \cdot (a, b)) \cdot (c, d) = (x, y) \cdot ((a, b) \cdot (c, d)) \quad (1.9)$$

$$\forall (x, y), (a, b) \in \mathbb{C} : (x, y) \cdot (a, b) = (a, b) \cdot (x, y) \quad (1.10)$$

$$\forall (x, y) \in \mathbb{C} : (x, y) \cdot (1, 0) = (x, y) \quad (1.11)$$

$$\forall (x, y) \in \mathbb{C} \setminus \{(0, 0)\} : (x, y) \cdot \left(\frac{x}{x^2+y^2}, \frac{-y}{x^2+y^2}\right) = (1, 0) \quad (1.12)$$

*Remark.* What we are stating here can be compressed in the language of algebra: equations (1.2)–(1.6) say that  $(\mathbb{C}, +)$  is an *Abelian group* with *unit element*  $(0, 0)$ , equations (1.8)–(1.12) that  $(\mathbb{C} \setminus \{(0, 0)\}, \cdot)$  is an abelian group with unit element  $(1, 0)$ . (If you don’t know what these terms mean—don’t worry, we will not have to deal with them.)

The definition of our multiplication implies the innocent looking statement

$$(0, 1) \cdot (0, 1) = (-1, 0). \quad (1.13)$$

This identity together with the fact that

$$(a, 0) \cdot (x, y) = (ax, ay)$$

allows an alternative notation for complex numbers. The latter implies that we can write

$$(x, y) = (x, 0) + (0, y) = (x, 0) \cdot (1, 0) + (y, 0) \cdot (0, 1).$$

If we think—in the spirit of our remark on the embedding of  $\mathbb{R}$  in  $\mathbb{C}$ —of  $(x, 0)$  and  $(y, 0)$  as the real numbers  $x$  and  $y$ , then this means that we can write any complex number  $(x, y)$  as a linear combination of  $(1, 0)$  and  $(0, 1)$ , with the real coefficients  $x$  and  $y$ .  $(1, 0)$ , in turn, can be thought of as the real number 1. So if we give  $(0, 1)$  a special name, say  $i$ , then the complex number that we used to call  $(x, y)$  can be written as  $x \cdot 1 + y \cdot i$ , or in short,

$$x + iy.$$

The number  $x$  is called the *real part* and  $y$  the *imaginary part*<sup>1</sup> of the complex number  $x + iy$ , often denoted as  $\operatorname{Re}(x + iy) = x$  and  $\operatorname{Im}(x + iy) = y$ . The identity (1.13) then reads

$$i^2 = -1.$$

We invite the reader to check that the definitions of our binary operations and Theorem 1.1 are coherent with the usual real arithmetic rules if we think of complex numbers as given in the form  $x + iy$ . This algebraic way of thinking about complex numbers has a name: a complex number written in the form  $x + iy$  where  $x$  and  $y$  are both real numbers is in *rectangular form*.

In fact, much more can now be said with the introduction of the square root of  $-1$ . It is not just that the polynomial  $z^2 + 1$  has roots, but *every* polynomial has roots in  $\mathbb{C}$ :

**Theorem 1.2.** (see Theorem 5.7) *Every non-constant polynomial of degree  $d$  has  $d$  roots (counting multiplicity) in  $\mathbb{C}$ .*

The proof of this theorem requires some important machinery, so we defer its proof and an extended discussion of it to Chapter 5.

## 1.2 From Algebra to Geometry and Back

Although we just introduced a new way of writing complex numbers, let's for a moment return to the  $(x, y)$ -notation. It suggests that one can think of a complex number as a two-dimensional real vector. When plotting these vectors in the plane  $\mathbb{R}^2$ , we will call the  $x$ -axis the *real axis* and the  $y$ -axis the *imaginary axis*. The addition that we defined for complex numbers resembles vector addition. The analogy stops at multiplication: there is no “usual” multiplication of two vectors in  $\mathbb{R}^2$  that gives another vector, and certainly not one that agrees with our definition of the product of two complex numbers.

Any vector in  $\mathbb{R}^2$  is defined by its two coordinates. On the other hand, it is also determined by its length and the angle it encloses with, say, the positive real axis; let's define these concepts thoroughly. The *absolute value* (sometimes also called the *modulus*)  $r = |z| \in \mathbb{R}$  of  $z = x + iy$  is

$$r = |z| := \sqrt{x^2 + y^2},$$

and an *argument* of  $z = x + iy$  is a number  $\phi \in \mathbb{R}$  such that

$$x = r \cos \phi \quad \text{and} \quad y = r \sin \phi.$$

---

<sup>1</sup>The name has historical reasons: people thought of complex numbers as unreal, imagined.

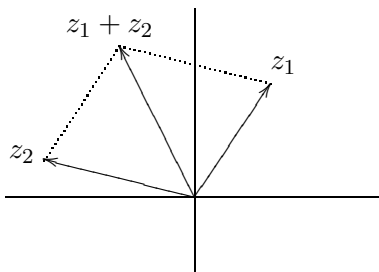

Figure 1.1: Addition of complex numbers.

A given complex number  $z = x + iy$  has infinitely many possible arguments. For instance, the number  $1 = 1 + 0i$  lies on the  $x$ -axis, and so has argument 0, but we could just as well say it has argument  $2\pi$ ,  $4\pi$ ,  $-2\pi$ , or  $2\pi * k$  for any integer  $k$ . The number  $0 = 0 + 0i$  has modulus 0, and every number  $\phi$  is an argument. Aside from the exceptional case of 0, for any complex number  $z$ , the arguments of  $z$  all differ by a multiple of  $2\pi$ , just as we saw for the example  $z = 1$ .

The absolute value of the difference of two vectors has a nice geometric interpretation:

**Proposition 1.3.** *Let  $z_1, z_2 \in \mathbb{C}$  be two complex numbers, thought of as vectors in  $\mathbb{R}^2$ , and let  $d(z_1, z_2)$  denote the distance between (the endpoints of) the two vectors in  $\mathbb{R}^2$  (see Figure 1.2). Then*

$$d(z_1, z_2) = |z_1 - z_2| = |z_2 - z_1|.$$

*Proof.* Let  $z_1 = x_1 + iy_1$  and  $z_2 = x_2 + iy_2$ . From geometry we know that  $d(z_1, z_2) = \sqrt{(x_1 - x_2)^2 + (y_1 - y_2)^2}$ . This is the definition of  $|z_1 - z_2|$ . Since  $(x_1 - x_2)^2 = (x_2 - x_1)^2$  and  $(y_1 - y_2)^2 = (y_2 - y_1)^2$ , this is also equal to  $|z_2 - z_1|$ .  $\square$

That  $|z_1 - z_2| = |z_2 - z_1|$  simply says that the vector from  $z_1$  to  $z_2$  has the same length as its inverse, the vector from  $z_2$  to  $z_1$ .

It is very useful to keep this geometric interpretation in mind when thinking about the absolute value of the difference of two complex numbers.

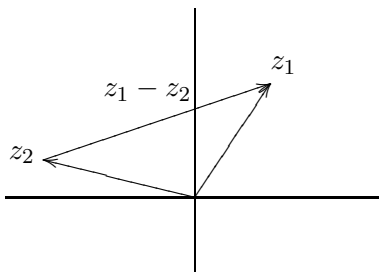

Figure 1.2: Geometry behind the “distance” between two complex numbers.

The first hint that the absolute value and argument of a complex number are useful concepts is the fact that they allow us to give a geometric interpretation for the multiplication of two complex numbers. Let's say we have two complex numbers,  $x_1 + iy_1$  with absolute value  $r_1$  and argument  $\phi_1$ , and  $x_2 + iy_2$  with absolute value  $r_2$  and argument  $\phi_2$ . This means, we can write



$x_1 + iy_1 = (r_1 \cos \phi_1) + i(r_1 \sin \phi_1)$  and  $x_2 + iy_2 = (r_2 \cos \phi_2) + i(r_2 \sin \phi_2)$  To compute the product, we make use of some classic trigonometric identities:

$$\begin{aligned} (x_1 + iy_1)(x_2 + iy_2) &= ((r_1 \cos \phi_1) + i(r_1 \sin \phi_1))((r_2 \cos \phi_2) + i(r_2 \sin \phi_2)) \\ &= (r_1 r_2 \cos \phi_1 \cos \phi_2 - r_1 r_2 \sin \phi_1 \sin \phi_2) + i(r_1 r_2 \cos \phi_1 \sin \phi_2 + r_1 r_2 \sin \phi_1 \cos \phi_2) \\ &= r_1 r_2 ((\cos \phi_1 \cos \phi_2 - \sin \phi_1 \sin \phi_2) + i(\cos \phi_1 \sin \phi_2 + \sin \phi_1 \cos \phi_2)) \\ &= r_1 r_2 (\cos(\phi_1 + \phi_2) + i \sin(\phi_1 + \phi_2)). \end{aligned}$$

So the absolute value of the product is  $r_1 r_2$  and (one of) its argument is  $\phi_1 + \phi_2$ . Geometrically, we are multiplying the lengths of the two vectors representing our two complex numbers, and adding their angles measured with respect to the positive  $x$ -axis.<sup>2</sup>

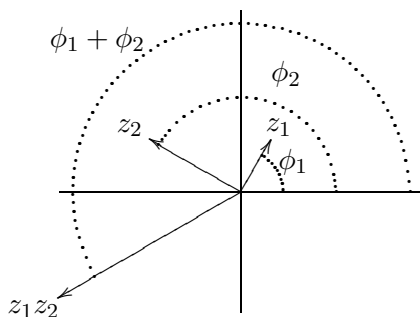

Figure 1.3: Multiplication of complex numbers.

In view of the above calculation, it should come as no surprise that we will have to deal with quantities of the form  $\cos \phi + i \sin \phi$  (where  $\phi$  is some real number) quite a bit. To save space, bytes, ink, etc., (and because “Mathematics is for lazy people”<sup>3</sup>) we introduce a shortcut notation and define

$$e^{i\phi} = \cos \phi + i \sin \phi.$$

At this point, this exponential notation is indeed purely a notation. We will later see in Chapter 3 that it has an intimate connection to the complex exponential function. For now, we motivate this maybe strange-seeming definition by collecting some of its properties. The reader is encouraged to prove them.

**Lemma 1.4.** For any  $\phi, \phi_1, \phi_2 \in \mathbb{R}$ ,

(a)  $e^{i\phi_1} e^{i\phi_2} = e^{i(\phi_1 + \phi_2)}$

(b)  $1/e^{i\phi} = e^{-i\phi}$

(c)  $e^{i(\phi + 2\pi)} = e^{i\phi}$

(d)  $|e^{i\phi}| = 1$

<sup>2</sup>One should convince oneself that there is no problem with the fact that there are many possible arguments for complex numbers, as both cosine and sine are periodic functions with period  $2\pi$ .

<sup>3</sup>Peter Hilton (Invited address, Hudson River Undergraduate Mathematics Conference 2000)

Formal ( $x, y$ )	Algebraic:	rectangular $x + iy$	exponential $re^{i\theta}$
	Geometric:	cartesian 	polar 

Figure 1.4: Five ways of thinking about a complex number  $z \in \mathbb{C}$ .

(e)  $\frac{d}{d\phi} e^{i\phi} = i e^{i\phi}$ .

With this notation, the sentence “The complex number  $x + iy$  has absolute value  $r$  and argument  $\phi$ ” now becomes the identity

$$x + iy = re^{i\phi}.$$

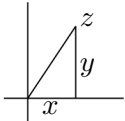
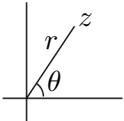
The left-hand side is often called the *rectangular form*, the right-hand side the *polar form* of this complex number.

We now have five different ways of thinking about a complex number: the formal definition, in rectangular form, in polar form, and geometrically using Cartesian coordinates or polar coordinates. Each of these five ways is useful in different situations, and translating between them is an essential ingredient in complex analysis. The five ways and their corresponding notation are listed in Figure 1.4.

### 1.3 Geometric Properties

From very basic geometric properties of triangles, we get the inequalities

$$-|z| \leq \operatorname{Re} z \leq |z| \quad \text{and} \quad -|z| \leq \operatorname{Im} z \leq |z|. \quad (1.14)$$

The square of the absolute value has the nice property

$$|x + iy|^2 = x^2 + y^2 = (x + iy)(x - iy).$$

This is one of many reasons to give the process of passing from  $x + iy$  to  $x - iy$  a special name:  $x - iy$  is called the (*complex*) *conjugate* of  $x + iy$ . We denote the conjugate by

$$\overline{x + iy} = x - iy.$$

Geometrically, conjugating  $z$  means reflecting the vector corresponding to  $z$  with respect to the real axis. The following collects some basic properties of the conjugate. Their easy proofs are left for the exercises.

**Lemma 1.5.** For any  $z, z_1, z_2 \in \mathbb{C}$ ,

(a)  $\overline{z_1 \pm z_2} = \overline{z_1} \pm \overline{z_2}$

(b)  $\overline{z_1 \cdot z_2} = \overline{z_1} \cdot \overline{z_2}$

(c)  $\overline{\left(\frac{z_1}{z_2}\right)} = \frac{\overline{z_1}}{\overline{z_2}}$

(d)  $\overline{\overline{z}} = z$

(e)  $|\overline{z}| = |z|$

(f)  $|z|^2 = z\overline{z}$

(g)  $\operatorname{Re} z = \frac{1}{2}(z + \overline{z})$

(h)  $\operatorname{Im} z = \frac{1}{2i}(z - \overline{z})$

(i)  $\overline{e^{i\phi}} = e^{-i\phi}$ .

From part (f) we have a neat formula for the inverse of a non-zero complex number:

$$z^{-1} = \frac{1}{z} = \frac{\overline{z}}{|z|^2}.$$

A famous geometric inequality (which holds for vectors in  $\mathbb{R}^n$ ) is the *triangle inequality*

$$|z_1 + z_2| \leq |z_1| + |z_2|.$$

By drawing a picture in the complex plane, you should be able to come up with a geometric proof of this inequality. To prove it algebraically, we make extensive use of Lemma 1.5:

$$\begin{aligned} |z_1 + z_2|^2 &= (z_1 + z_2) \overline{(z_1 + z_2)} \\ &= (z_1 + z_2) (\overline{z_1} + \overline{z_2}) \\ &= z_1 \overline{z_1} + z_1 \overline{z_2} + z_2 \overline{z_1} + z_2 \overline{z_2} \\ &= |z_1|^2 + z_1 \overline{z_2} + \overline{z_1 z_2} + |z_2|^2 \\ &= |z_1|^2 + 2 \operatorname{Re}(z_1 \overline{z_2}) + |z_2|^2. \end{aligned}$$

Finally by (1.14)

$$\begin{aligned} |z_1 + z_2|^2 &\leq |z_1|^2 + 2|z_1 \overline{z_2}| + |z_2|^2 \\ &= |z_1|^2 + 2|z_1| |\overline{z_2}| + |z_2|^2 \\ &= |z_1|^2 + 2|z_1| |z_2| + |z_2|^2 \\ &= (|z_1| + |z_2|)^2, \end{aligned}$$

which is equivalent to our claim.

For future reference we list several variants of the triangle inequality:

**Lemma 1.6.** For  $z_1, z_2, \dots \in \mathbb{C}$ , we have the following identities:

- (a) *The triangle inequality:*  $|\pm z_1 \pm z_2| \leq |z_1| + |z_2|$ .
- (b) *The reverse triangle inequality:*  $|\pm z_1 \pm z_2| \geq |z_1| - |z_2|$ .
- (c) *The triangle inequality for sums:*  $\left| \sum_{k=1}^n z_k \right| \leq \sum_{k=1}^n |z_k|$ .

The first inequality is just a rewrite of the original triangle inequality, using the fact that  $|\pm z| = |z|$ , and the last follows by induction. The reverse triangle inequality is proved in Exercise 22.

## 1.4 Elementary Topology of the Plane

In Section 1.2 we saw that the complex numbers  $\mathbb{C}$ , which were initially defined algebraically, can be identified with the points in the Euclidean plane  $\mathbb{R}^2$ . In this section we collect some definitions and results concerning the topology of the plane. While the definitions are essential and will be used frequently, we will need the following theorems only at a limited number of places in the remainder of the book; the reader who is willing to accept the topological arguments in later proofs on faith may skip the theorems in this section.

Recall that if  $z, w \in \mathbb{C}$ , then  $|z - w|$  is the distance between  $z$  and  $w$  as points in the plane. So if we fix a complex number  $a$  and a positive real number  $r$  then the set of  $z$  satisfying  $|z - a| = r$  is the set of points at distance  $r$  from  $a$ ; that is, this is the circle with center  $a$  and radius  $r$ . The *inside* of this circle is called the *open disk* with center  $a$  and radius  $r$ , and is written  $D_r(a)$ . That is,  $D_r(a) = \{z \in \mathbb{C} : |z - a| < r\}$ . Notice that this does not include the circle itself.

We need some terminology for talking about subsets of  $\mathbb{C}$ .

**Definition 1.7.** Suppose  $E$  is any subset of  $\mathbb{C}$ .

- (a) A point  $a$  is an *interior* point of  $E$  if some open disk with center  $a$  lies in  $E$ .
- (b) A point  $b$  is a *boundary* point of  $E$  if every open disk centered at  $b$  contains a point in  $E$  and also a point that is not in  $E$ .
- (c) A point  $c$  is an *accumulation* point of  $E$  if every open disk centered at  $c$  contains a point of  $E$  different from  $c$ .
- (d) A point  $d$  is an *isolated* point of  $E$  if it lies in  $E$  and some open disk centered at  $d$  contains no point of  $E$  other than  $d$ .

The idea is that if you don't move too far from an interior point of  $E$  then you remain in  $E$ ; but at a boundary point you can make an arbitrarily small move and get to a point inside  $E$  and you can also make an arbitrarily small move and get to a point outside  $E$ .

**Definition 1.8.** A set is *open* if all its points are interior points. A set is *closed* if it contains all its boundary points.

**Example 1.9.** For  $R > 0$  and  $z_0 \in \mathbb{C}$ ,  $\{z \in \mathbb{C} : |z - z_0| < R\}$  and  $\{z \in \mathbb{C} : |z - z_0| > R\}$  are open.  $\{z \in \mathbb{C} : |z - z_0| \leq R\}$  is closed.

**Example 1.10.**  $\mathbb{C}$  and the empty set  $\emptyset$  are open. They are also closed!

**Definition 1.11.** The *boundary* of a set  $E$ , written  $\partial E$ , is the set of all boundary points of  $E$ . The *interior* of  $E$  is the set of all interior points of  $E$ . The *closure* of  $E$ , written  $\overline{E}$ , is the set of points in  $E$  together with all boundary points of  $E$ .

**Example 1.12.** If  $G$  is the open disk  $\{z \in \mathbb{C} : |z - z_0| < R\}$  then

$$\overline{G} = \{z \in \mathbb{C} : |z - z_0| \leq R\} \quad \text{and} \quad \partial G = \{z \in \mathbb{C} : |z - z_0| = R\}.$$

That is,  $\overline{G}$  is a closed disk and  $\partial G$  is a circle.

One notion that is somewhat subtle in the complex domain is the idea of *connectedness*. Intuitively, a set is connected if it is “in one piece.” In the reals a set is connected if and only if it is an interval, so there is little reason to discuss the matter. However, in the plane there is a vast variety of connected subsets, so a definition is necessary.

**Definition 1.13.** Two sets  $X, Y \subseteq \mathbb{C}$  are *separated* if there are disjoint open sets  $A$  and  $B$  so that  $X \subseteq A$  and  $Y \subseteq B$ . A set  $W \subseteq \mathbb{C}$  is *connected* if it is impossible to find two separated non-empty sets whose union is equal to  $W$ . A *region* is a connected open set.

The idea of separation is that the two open sets  $A$  and  $B$  ensure that  $X$  and  $Y$  cannot just “stick together.” It is usually easy to check that a set is *not* connected. For example, the intervals  $X = [0, 1)$  and  $Y = (1, 2]$  on the real axis are separated: There are infinitely many choices for  $A$  and  $B$  that work; one choice is  $A = D_1(0)$  (the open disk with center 0 and radius 1) and  $B = D_1(2)$  (the open disk with center 2 and radius 1). Hence their union, which is  $[0, 2] \setminus \{1\}$ , is not connected. On the other hand, it is hard to use the definition to show that a set *is* connected, since we have to rule out any possible separation.

One type of connected set that we will use frequently is a curve.

**Definition 1.14.** A *path* or *curve* in  $\mathbb{C}$  is the image of a continuous function  $\gamma: [a, b] \rightarrow \mathbb{C}$ , where  $[a, b]$  is a closed interval in  $\mathbb{R}$ . The path  $\gamma$  is *smooth* if  $\gamma$  is differentiable.

We say that the curve is *parametrized* by  $\gamma$ . It is a customary and practical abuse of notation to use the same letter for the curve and its parametrization. We emphasize that a curve must have a parametrization, and that the parametrization must be defined and continuous on a *closed and bounded* interval  $[a, b]$ .

Since we may regard  $\mathbb{C}$  as identified with  $\mathbb{R}^2$ , a path can be specified by giving two continuous real-valued functions of a real variable,  $x(t)$  and  $y(t)$ , and setting  $\gamma(t) = x(t) + y(t)i$ . A curve is *closed* if  $\gamma(a) = \gamma(b)$  and is a *simple closed curve* if  $\gamma(s) = \gamma(t)$  implies  $s = a$  and  $t = b$  or  $s = b$  and  $t = a$ , that is, the curve does not cross itself.

The following seems intuitively clear, but its proof requires more preparation in topology:

**Proposition 1.15.** *Any curve is connected.*

The next theorem gives an easy way to check whether an open set is connected, and also gives a very useful property of open connected sets.

**Theorem 1.16.** *If  $W$  is a subset of  $\mathbb{C}$  that has the property that any two points in  $W$  can be connected by a curve in  $W$  then  $W$  is connected. On the other hand, if  $G$  is a connected open subset of  $\mathbb{C}$  then any two points of  $G$  may be connected by a curve in  $G$ ; in fact, we can connect any two points of  $G$  by a chain of horizontal and vertical segments lying in  $G$ .*

A *chain of segments* in  $G$  means the following: there are points  $z_0, z_1, \dots, z_n$  so that, for each  $k$ ,  $z_k$  and  $z_{k+1}$  are the endpoints of a horizontal or vertical segment which lies entirely in  $G$ . (It is not hard to parametrize such a chain, so it determines a curve.)

As an example, let  $G$  be the open disk with center 0 and radius 2. Then any two points in  $G$  can be connected by a chain of at most 2 segments in  $G$ , so  $G$  is connected. Now let  $G_0 = G \setminus \{0\}$ ; this is the punctured disk obtained by removing the center from  $G$ . Then  $G_0$  is open and it is connected, but now you may need more than two segments to connect points. For example, you need three segments to connect  $-1$  to  $1$  since you cannot go through 0.

**Warning:** The second part of Theorem 1.16 is not generally true if  $G$  is not open. For example, circles are connected but there is no way to connect two distinct points of a circle by a chain of segments which are subsets of the circle. A more extreme example, discussed in topology texts, is the “topologist’s sine curve,” which is a connected set  $S \subset \mathbb{C}$  that contains points that cannot be connected by a curve of any sort inside  $S$ .

The reader may skip the following proof. It is included to illustrate some common techniques in dealing with connected sets.

*Proof of Theorem 1.16.* Suppose, first, that any two points of  $G$  may be connected by a path that lies in  $G$ . If  $G$  is not connected then we can write it as a union of two non-empty separated subsets  $X$  and  $Y$ . So there are disjoint open sets  $A$  and  $B$  so that  $X \subseteq A$  and  $Y \subseteq B$ . Since  $X$  and  $Y$  are disjoint we can find  $a \in X$  and  $b \in Y$ . Let  $\gamma$  be a path in  $G$  that connects  $a$  to  $b$ . Then  $X_\gamma = X \cap \gamma$  and  $Y_\gamma = Y \cap \gamma$  are disjoint and non-empty, their union is  $\gamma$ , and they are separated by  $A$  and  $B$ . But this means that  $\gamma$  is not connected, and this contradicts Proposition 1.15.

Now suppose that  $G$  is a connected open set. Choose a point  $z_0 \in G$  and define two sets:  $A$  is the set of all points  $a$  so that there is a chain of segments in  $G$  connecting  $z_0$  to  $a$ , and  $B$  is the set of points in  $G$  that are not in  $A$ .

Suppose  $a$  is in  $A$ . Since  $a \in G$  there is an open disk  $D$  with center  $a$  that is contained in  $G$ . We can connect  $z_0$  to any point  $z$  in  $D$  by following a chain of segments from  $z_0$  to  $a$ , and then adding at most two segments in  $D$  that connect  $a$  to  $z$ . That is, each point of  $D$  is in  $A$ , so we have shown that  $A$  is open.

Now suppose  $b$  is in  $B$ . Since  $b \in G$  there is an open disk  $D$  centered at  $b$  that lies in  $G$ . If  $z_0$  could be connected to any point in  $D$  by a chain of segments in  $G$  then, extending this chain by at most two more segments, we could connect  $z_0$  to  $b$ , and this is impossible. Hence  $z_0$  cannot connect to any point of  $D$  by a chain of segments in  $G$ , so  $D \subseteq B$ . So we have shown that  $B$  is open.

Now  $G$  is the disjoint union of the two open sets  $A$  and  $B$ . If these are both non-empty then they form a separation of  $G$ , which is impossible. But  $z_0$  is in  $A$  so  $A$  is not empty, and so  $B$  must be empty. That is,  $G = A$ , so  $z_0$  can be connected to any point of  $G$  by a sequence of segments in  $G$ . Since  $z_0$  could be any point in  $G$ , this finishes the proof.  $\square$

## 1.5 Theorems from Calculus

Here are a few theorems from real calculus that we will make use of in the course of the text.

**Theorem 1.17** (Extreme-Value Theorem). *Any continuous real-valued function defined on a closed and bounded subset of  $\mathbb{R}^n$  has a minimum value and a maximum value.*

**Theorem 1.18** (Mean-Value Theorem). *Suppose  $I \subseteq \mathbb{R}$  is an interval,  $f : I \rightarrow \mathbb{R}$  is differentiable, and  $x, x + \Delta x \in I$ . Then there is  $0 < a < 1$  such that*

$$\frac{f(x + \Delta x) - f(x)}{\Delta x} = f'(x + a\Delta x).$$

Many of the most important results of analysis concern combinations of limit operations. The most important of all calculus theorems combines differentiation and integration (in two ways):

**Theorem 1.19** (Fundamental Theorem of Calculus). *Suppose  $f : [a, b] \rightarrow \mathbb{R}$  is continuous. Then*

- (a) *If  $F$  is defined by  $F(x) = \int_a^x f(t) dt$  then  $F$  is differentiable and  $F'(x) = f(x)$ .*  
 (b) *If  $F$  is any antiderivative of  $f$  (that is,  $F' = f$ ) then  $\int_a^b f(x) dx = F(b) - F(a)$ .*

For functions of several variables we can perform differentiation operations, or integration operations, in any order, if we have sufficient continuity:

**Theorem 1.20** (Equality of mixed partials). *If the mixed partials  $\frac{\partial^2 f}{\partial x \partial y}$  and  $\frac{\partial^2 f}{\partial y \partial x}$  are defined on an open set  $G$  and are continuous at a point  $(x_0, y_0)$  in  $G$  then they are equal at  $(x_0, y_0)$ .*

**Theorem 1.21** (Equality of iterated integrals). *If  $f$  is continuous on the rectangle given by  $a \leq x \leq b$  and  $c \leq y \leq d$  then the iterated integrals  $\int_a^b \int_c^d f(x, y) dy dx$  and  $\int_c^d \int_a^b f(x, y) dx dy$  are equal.*

Finally, we can apply differentiation and integration with respect to different variables in either order:

**Theorem 1.22** (Leibniz's<sup>4</sup> Rule). *Suppose  $f$  is continuous on the rectangle  $R$  given by  $a \leq x \leq b$  and  $c \leq y \leq d$ , and suppose the partial derivative  $\frac{\partial f}{\partial x}$  exists and is continuous on  $R$ . Then*

$$\frac{d}{dx} \int_c^d f(x, y) dy = \int_c^d \frac{\partial f}{\partial x}(x, y) dy.$$

## Exercises

1. Let  $z = 1 + 2i$  and  $w = 2 - i$ . Compute:

- (a)  $z + 3w$ .  
 (b)  $\bar{w} - z$ .  
 (c)  $z^3$ .  
 (d)  $\operatorname{Re}(w^2 + w)$ .  
 (e)  $z^2 + \bar{z} + i$ .

2. Find the real and imaginary parts of each of the following:

- (a)  $\frac{z-a}{z+a}$  ( $a \in \mathbb{R}$ ).

---

<sup>4</sup>Named after Gottfried Wilhelm Leibniz (1646–1716). For more information about Leibniz, see <http://www-groups.dcs.st-and.ac.uk/~history/Biographies/Leibniz.html>.

- (b)  $\frac{3+5i}{7i+1}$ .
- (c)  $\left(\frac{-1+i\sqrt{3}}{2}\right)^3$ .
- (d)  $i^n$  for any  $n \in \mathbb{Z}$ .
3. Find the absolute value and conjugate of each of the following:
- (a)  $-2 + i$ .
- (b)  $(2 + i)(4 + 3i)$ .
- (c)  $\frac{3-i}{\sqrt{2}+3i}$ .
- (d)  $(1 + i)^6$ .
4. Write in polar form:
- (a)  $2i$ .
- (b)  $1 + i$ .
- (c)  $-3 + \sqrt{3}i$ .
- (d)  $-i$ .
- (e)  $(2 - i)^2$ .
- (f)  $|3 - 4i|$ .
- (g)  $\sqrt{5} - i$ .
- (h)  $\left(\frac{1-i}{\sqrt{3}}\right)^4$ .
5. Write in rectangular form:
- (a)  $\sqrt{2} e^{i3\pi/4}$ .
- (b)  $34 e^{i\pi/2}$ .
- (c)  $-e^{i250\pi}$ .
- (d)  $2e^{4\pi i}$ .
6. Write in both polar and rectangular form:
- (a)  $2^i$
- (b)  $e^{\ln(5)}i$
- (c)  $e^{1+i\pi/2}$
- (d)  $\frac{d}{d\phi} e^{\phi+i\phi}$
7. Prove the quadratic formula works for complex numbers, regardless of whether the discriminant is negative. That is, prove, the roots of the equation  $az^2 + bz + c = 0$ , where  $a, b, c \in \mathbb{C}$ , are  $\frac{-b \pm \sqrt{b^2 - 4ac}}{2a}$  as long as  $a \neq 0$ .
8. Use the quadratic formula to solve the following equations. Put your answers in standard form.



- (a)  $z^2 + 25 = 0$ .
- (b)  $2z^2 + 2z + 5 = 0$ .
- (c)  $5z^2 + 4z + 1 = 0$ .
- (d)  $z^2 - z = 1$ .
- (e)  $z^2 = 2z$ .
9. Fix  $A \in \mathbb{C}$  and  $B \in \mathbb{R}$ . Show that the equation  $|z^2| + \operatorname{Re}(Az) + B = 0$  has a solution if and only if  $|A^2| \geq 4B$ . When solutions exist, show the solution set is a circle.
10. Find all solutions to the following equations:
- (a)  $z^6 = 1$ .
- (b)  $z^4 = -16$ .
- (c)  $z^6 = -9$ .
- (d)  $z^6 - z^3 - 2 = 0$ .
11. Show that  $|z| = 1$  if and only if  $\frac{1}{z} = \bar{z}$ .
12. Show that
- (a)  $z$  is a real number if and only if  $z = \bar{z}$ ;
- (b)  $z$  is either real or purely imaginary if and only if  $(\bar{z})^2 = z^2$ .
13. Find all solutions of the equation  $z^2 + 2z + (1 - i) = 0$ .
14. Prove Theorem 1.1.
15. Show that if  $z_1 z_2 = 0$  then  $z_1 = 0$  or  $z_2 = 0$ .
16. Prove Lemma 1.4.
17. Use Lemma 1.4 to derive the triple angle formulas:
- (a)  $\cos 3\theta = \cos^3 \theta - 3 \cos \theta \sin^2 \theta$ .
- (b)  $\sin 3\theta = 3 \cos^2 \theta \sin \theta - \sin^3 \theta$ .
18. Prove Lemma 1.5.
19. Sketch the following sets in the complex plane:
- (a)  $\{z \in \mathbb{C} : |z - 1 + i| = 2\}$ .
- (b)  $\{z \in \mathbb{C} : |z - 1 + i| \leq 2\}$ .
- (c)  $\{z \in \mathbb{C} : \operatorname{Re}(z + 2 - 2i) = 3\}$ .
- (d)  $\{z \in \mathbb{C} : |z - i| + |z + i| = 3\}$ .
- (e)  $\{z \in \mathbb{C} : |z| = |z + 1|\}$ .
20. Show the equation  $2|z| = |z + i|$  describes a circle.

21. Suppose  $p$  is a polynomial with real coefficients. Prove that
- $\overline{p(z)} = p(\bar{z})$ .
  - $p(z) = 0$  if and only if  $p(\bar{z}) = 0$ .
22. Prove the reverse triangle inequality  $|z_1 - z_2| \geq |z_1| - |z_2|$ .
23. Use the previous exercise to show that  $\left| \frac{1}{z^2 - 1} \right| \leq \frac{1}{3}$  for every  $z$  on the circle  $z = 2e^{i\theta}$ .
24. Sketch the following sets and determine whether they are open, closed, or neither; bounded; connected.
- $|z + 3| < 2$ .
  - $|\operatorname{Im} z| < 1$ .
  - $0 < |z - 1| < 2$ .
  - $|z - 1| + |z + 1| = 2$ .
  - $|z - 1| + |z + 1| < 3$ .
25. What are the boundaries of the sets in the previous exercise?
26. The set  $E$  is the set of points  $z$  in  $\mathbb{C}$  satisfying either  $z$  is real and  $-2 < z < -1$ , or  $|z| < 1$ , or  $z = 1$  or  $z = 2$ .
- Sketch the set  $E$ , being careful to indicate exactly the points that are in  $E$ .
  - Determine the interior points of  $E$ .
  - Determine the boundary points of  $E$ .
  - Determine the isolated points of  $E$ .
27. The set  $E$  in the previous exercise can be written in three different ways as the union of two disjoint nonempty separated subsets. Describe them, and in each case say briefly why the subsets are separated.
28. Show that the union of two regions with nonempty intersection is itself a region.
29. Show that if  $A \subset B$  and  $B$  is closed, then  $\partial A \subset B$ . Similarly, if  $A \subset B$  and  $A$  is open, show  $A$  is contained in the interior of  $B$ .
30. Let  $G$  be the annulus determined by the conditions  $2 < |z| < 3$ . This is a connected open set. Find the maximum number of horizontal and vertical segments in  $G$  needed to connect two points of  $G$ .
31. Prove Leibniz's Rule: Define  $F(x) = \int_c^d f(x, y) dy$ , get an expression for  $F(x) - F(a)$  as an iterated integral by writing  $f(x, y) - f(a, y)$  as the integral of  $\frac{\partial f}{\partial x}$ , interchange the order of integrations, and then differentiate using the Fundamental Theorem of Calculus.

## Chapter 2

# Differentiation

*Mathematical study and research are very suggestive of mountaineering. Whymper made several efforts before he climbed the Matterhorn in the 1860's and even then it cost the life of four of his party. Now, however, any tourist can be hauled up for a small cost, and perhaps does not appreciate the difficulty of the original ascent. So in mathematics, it may be found hard to realise the great initial difficulty of making a little step which now seems so natural and obvious, and it may not be surprising if such a step has been found and lost again.*

Louis Joel Mordell (1888–1972)

### 2.1 First Steps

A (complex) function  $f$  is a mapping from a subset  $G \subseteq \mathbb{C}$  to  $\mathbb{C}$  (in this situation we will write  $f : G \rightarrow \mathbb{C}$  and call  $G$  the *domain* of  $f$ ). This means that each element  $z \in G$  gets mapped to exactly one complex number, called the *image* of  $z$  and usually denoted by  $f(z)$ . So far there is nothing that makes complex functions any more special than, say, functions from  $\mathbb{R}^m$  to  $\mathbb{R}^n$ . In fact, we can construct many familiar looking functions from the standard calculus repertoire, such as  $f(z) = z$  (the *identity map*),  $f(z) = 2z + i$ ,  $f(z) = z^3$ , or  $f(z) = \frac{1}{z}$ . The former three could be defined on all of  $\mathbb{C}$ , whereas for the latter we have to exclude the origin  $z = 0$ . On the other hand, we could construct some functions which make use of a certain representation of  $z$ , for example,  $f(x, y) = x - 2iy$ ,  $f(x, y) = y^2 - ix$ , or  $f(r, \phi) = 2re^{i(\phi+\pi)}$ .

Maybe *the* fundamental principle of analysis is that of a limit. The philosophy of the following definition is not restricted to complex functions, but for sake of simplicity we only state it for those functions.

**Definition 2.1.** Suppose  $f$  is a complex function with domain  $G$  and  $z_0$  is an accumulation point of  $G$ . Suppose there is a complex number  $w_0$  such that for every  $\epsilon > 0$ , we can find  $\delta > 0$  so that for all  $z \in G$  satisfying  $0 < |z - z_0| < \delta$  we have  $|f(z) - w_0| < \epsilon$ . Then  $w_0$  is the *limit* of  $f$  as  $z$  approaches  $z_0$ , in short

$$\lim_{z \rightarrow z_0} f(z) = w_0.$$

This definition is the same as is found in most calculus texts. The reason we require that  $z_0$  is an accumulation point of the domain is just that we need to be sure that there are points  $z$  of the domain which are arbitrarily close to  $z_0$ . Just as in the real case, the definition does not require

that  $z_0$  is in the domain of  $f$  and, if  $z_0$  is in the domain of  $f$ , the definition explicitly ignores the value of  $f(z_0)$ . That is why we require  $0 < |z - z_0|$ .

Just as in the real case the limit  $w_0$  is unique if it exists. It is often useful to investigate limits by restricting the way the point  $z$  “approaches”  $z_0$ . The following is a easy consequence of the definition.

**Lemma 2.2.** *Suppose  $\lim_{z \rightarrow z_0} f(z)$  exists and has the value  $w_0$ , as above. Suppose  $G_0 \subseteq G$ , and suppose  $z_0$  is an accumulation point of  $G_0$ . If  $f_0$  is the restriction of  $f$  to  $G_0$  then  $\lim_{z \rightarrow z_0} f_0(z)$  exists and has the value  $w_0$ .*

The definition of limit in the complex domain has to be treated with a little more care than its real companion; this is illustrated by the following example.

**Example 2.3.**  $\lim_{z \rightarrow 0} \frac{\bar{z}}{z}$  does not exist.

To see this, we try to compute this “limit” as  $z \rightarrow 0$  on the real and on the imaginary axis. In the first case, we can write  $z = x \in \mathbb{R}$ , and hence

$$\lim_{z \rightarrow 0} \frac{\bar{z}}{z} = \lim_{x \rightarrow 0} \frac{\bar{x}}{x} = \lim_{x \rightarrow 0} \frac{x}{x} = 1.$$

In the second case, we write  $z = iy$  where  $y \in \mathbb{R}$ , and then

$$\lim_{z \rightarrow 0} \frac{\bar{z}}{z} = \lim_{y \rightarrow 0} \frac{\overline{iy}}{iy} = \lim_{y \rightarrow 0} \frac{-iy}{iy} = -1.$$

So we get a different “limit” depending on the direction from which we approach 0. Lemma 2.2 then implies that  $\lim_{z \rightarrow 0} \frac{\bar{z}}{z}$  does not exist.

On the other hand, the following “usual” limit rules are valid for complex functions; the proofs of these rules are everything but trivial and make for nice exercises.

**Lemma 2.4.** *Let  $f$  and  $g$  be complex functions and  $c, z_0 \in \mathbb{C}$ . If  $\lim_{z \rightarrow z_0} f(z)$  and  $\lim_{z \rightarrow z_0} g(z)$  exist, then:*

$$(a) \lim_{z \rightarrow z_0} f(z) + c \lim_{z \rightarrow z_0} g(z) = \lim_{z \rightarrow z_0} (f(z) + cg(z))$$

$$(b) \lim_{z \rightarrow z_0} f(z) \cdot \lim_{z \rightarrow z_0} g(z) = \lim_{z \rightarrow z_0} (f(z) \cdot g(z))$$

$$(c) \lim_{z \rightarrow z_0} f(z) / \lim_{z \rightarrow z_0} g(z) = \lim_{z \rightarrow z_0} (f(z)/g(z));$$

*In the last identity we also require that  $\lim_{z \rightarrow z_0} g(z) \neq 0$ .*

Because the definition of the limit is somewhat elaborate, the following fundamental definition looks almost trivial.

**Definition 2.5.** Suppose  $f$  is a complex function. If  $z_0$  is in the domain of the function and either  $z_0$  is an isolated point of the domain or

$$\lim_{z \rightarrow z_0} f(z) = f(z_0)$$

then  $f$  is *continuous* at  $z_0$ . More generally,  $f$  is *continuous* on  $G \subseteq \mathbb{C}$  if  $f$  is continuous at every  $z \in G$ .

Just as in the real case, we can “take the limit inside” a continuous function:

**Lemma 2.6.** *If  $f$  is continuous at an accumulation point  $w_0$  and  $\lim_{z \rightarrow z_0} g(z) = w_0$  then  $\lim_{z \rightarrow z_0} f(g(z)) = f(w_0)$ . In other words,*

$$\lim_{z \rightarrow z_0} f(g(z)) = f\left(\lim_{z \rightarrow z_0} g(z)\right).$$

This lemma implies that direct substitution is allowed when  $f$  is continuous at the limit point. In particular, that if  $f$  is continuous at  $w_0$  then  $\lim_{w \rightarrow w_0} f(w) = f(w_0)$ .

## 2.2 Differentiability and Holomorphicity

The fact that limits such as  $\lim_{z \rightarrow 0} \frac{\bar{z}}{z}$  do not exist points to something special about complex numbers which has no parallel in the reals—we can express a function in a very compact way in one variable, yet it shows some peculiar behavior “in the limit.” We will repeatedly notice this kind of behavior; one reason is that when trying to compute a limit of a function as, say,  $z \rightarrow 0$ , we have to allow  $z$  to approach the point 0 in any way. On the real line there are only two directions to approach 0—from the left or from the right (or some combination of those two). In the complex plane, we have an additional dimension to play with. This means that the statement “A complex function has a limit...” is in many senses stronger than the statement “A real function has a limit...” This difference becomes apparent most baldly when studying derivatives.

**Definition 2.7.** Suppose  $f : G \rightarrow \mathbb{C}$  is a complex function and  $z_0$  is an interior point of  $G$ . The *derivative of  $f$  at  $z_0$*  is defined as

$$f'(z_0) = \lim_{z \rightarrow z_0} \frac{f(z) - f(z_0)}{z - z_0},$$

provided this limit exists. In this case,  $f$  is called *differentiable* at  $z_0$ . If  $f$  is differentiable for all points in an open disk centered at  $z_0$  then  $f$  is called *holomorphic* at  $z_0$ . The function  $f$  is *holomorphic* on the open set  $G \subseteq \mathbb{C}$  if it is differentiable (and hence holomorphic) at every point in  $G$ . Functions which are differentiable (and hence holomorphic) in the whole complex plane  $\mathbb{C}$  are called *entire*.

The difference quotient limit which defines  $f'(z_0)$  can be rewritten as

$$f'(z_0) = \lim_{h \rightarrow 0} \frac{f(z_0 + h) - f(z_0)}{h}.$$

This equivalent definition is sometimes easier to handle. Note that  $h$  is *not* a real number but can rather approach zero from anywhere in the complex plane.

The fact that the notions of differentiability and holomorphicity are actually different is seen in the following examples.

**Example 2.8.** The function  $f(z) = z^3$  is entire, that is, holomorphic in  $\mathbb{C}$ : For any  $z_0 \in \mathbb{C}$ ,

$$\begin{aligned} \lim_{z \rightarrow z_0} \frac{f(z) - f(z_0)}{z - z_0} &= \lim_{z \rightarrow z_0} \frac{z^3 - z_0^3}{z - z_0} = \lim_{z \rightarrow z_0} \frac{(z^2 + zz_0 + z_0^2)(z - z_0)}{z - z_0} \\ &= \lim_{z \rightarrow z_0} z^2 + zz_0 + z_0^2 = 3z_0^2. \end{aligned}$$

**Example 2.9.** The function  $f(z) = \bar{z}^2$  is differentiable at 0 and nowhere else (in particular,  $f$  is not holomorphic at 0): Let's write  $z = z_0 + re^{i\phi}$ . Then

$$\begin{aligned} \frac{\bar{z}^2 - \bar{z}_0^2}{z - z_0} &= \frac{\overline{(z_0 + re^{i\phi})}^2 - \bar{z}_0^2}{z_0 + re^{i\phi} - z_0} = \frac{(\bar{z}_0 + re^{-i\phi})^2 - \bar{z}_0^2}{re^{i\phi}} \\ &= \frac{\bar{z}_0^2 + 2\bar{z}_0re^{-i\phi} + r^2e^{-2i\phi} - \bar{z}_0^2}{re^{i\phi}} \\ &= \frac{2\bar{z}_0re^{-i\phi} + r^2e^{-2i\phi}}{re^{i\phi}} = 2\bar{z}_0e^{-2i\phi} + re^{-3i\phi}. \end{aligned}$$

If  $z_0 \neq 0$  then the limit of the right-hand side as  $z \rightarrow z_0$  does not exist since  $r \rightarrow 0$  and we get different answers for horizontal approach ( $\phi = 0$ ) and for vertical approach ( $\phi = \pi/2$ ). (A more entertaining way to see this is to use, for example,  $z(t) = z_0 + \frac{1}{t}e^{it}$ , which approaches  $z_0$  as  $t \rightarrow \infty$ .) On the other hand, if  $z_0 = 0$  then the right-hand side equals  $re^{-3i\phi} = |z|e^{-3i\phi}$ . Hence

$$\lim_{z \rightarrow 0} \left| \frac{\bar{z}^2}{z} \right| = \lim_{z \rightarrow 0} |z|e^{-3i\phi} = \lim_{z \rightarrow 0} |z| = 0,$$

which implies that

$$\lim_{z \rightarrow 0} \frac{\bar{z}^2}{z} = 0.$$

**Example 2.10.** The function  $f(z) = \bar{z}$  is nowhere differentiable:

$$\lim_{z \rightarrow z_0} \frac{\bar{z} - \bar{z}_0}{z - z_0} = \lim_{z \rightarrow z_0} \frac{\overline{z - z_0}}{z - z_0} = \lim_{z \rightarrow 0} \frac{\bar{z}}{z}$$

does not exist, as discussed earlier.

The basic properties for derivatives are similar to those we know from real calculus. In fact, one should convince oneself that the following rules follow mostly from properties of the limit. (The 'chain rule' needs a little care to be worked out.)

**Lemma 2.11.** Suppose  $f$  and  $g$  are differentiable at  $z \in \mathbb{C}$ , and that  $c \in \mathbb{C}$ ,  $n \in \mathbb{Z}$ , and  $h$  is differentiable at  $g(z)$ .

- (a)  $(f(z) + cg(z))' = f'(z) + cg'(z)$
- (b)  $(f(z) \cdot g(z))' = f'(z)g(z) + f(z)g'(z)$
- (c)  $(f(z)/g(z))' = \frac{f'(z)g(z) - f(z)g'(z)}{g(z)^2}$
- (d)  $(z^n)' = nz^{n-1}$
- (e)  $(h(g(z)))' = h'(g(z))g'(z)$ .

In the third identity we have to be aware of division by zero.

We end this section with yet another differentiation rule, that for inverse functions. As in the real case, this rule is only defined for functions which are bijections. A function  $f : G \rightarrow H$  is *one-to-one* if for every image  $w \in H$  there is a unique  $z \in G$  such that  $f(z) = w$ . The function is *onto* if every  $w \in H$  has a preimage  $z \in G$  (that is, there exists a  $z \in G$  such that  $f(z) = w$ ). A *bijection* is a function which is both one-to-one and onto. If  $f : G \rightarrow H$  is a bijection then  $g$  is the *inverse of  $f$*  if for all  $z \in H$ ,  $f(g(z)) = z$ .

**Lemma 2.12.** *Suppose  $G$  and  $H$  are open sets in  $\mathbb{C}$ ,  $f : G \rightarrow H$  is a bijection,  $g : H \rightarrow G$  is the inverse function of  $f$ , and  $z_0 \in H$ . If  $f$  is differentiable at  $g(z_0)$ ,  $f'(g(z_0)) \neq 0$ , and  $g$  is continuous at  $z_0$  then  $g$  is differentiable at  $z_0$  with*

$$g'(z_0) = \frac{1}{f'(g(z_0))}.$$

*Proof.* We have:

$$g'(z_0) = \lim_{z \rightarrow z_0} \frac{g(z) - g(z_0)}{z - z_0} = \lim_{z \rightarrow z_0} \frac{g(z) - g(z_0)}{f(g(z)) - f(g(z_0))} = \lim_{z \rightarrow z_0} \frac{1}{\frac{f(g(z)) - f(g(z_0))}{g(z) - g(z_0)}}.$$

Because  $g(z) \rightarrow g(z_0)$  as  $z \rightarrow z_0$ , we obtain:

$$g'(z_0) = \lim_{g(z) \rightarrow g(z_0)} \frac{1}{\frac{f(g(z)) - f(g(z_0))}{g(z) - g(z_0)}}.$$

Finally, as the denominator of this last term is continuous at  $z_0$ , by Lemma 2.6 we have:

$$g'(z_0) = \frac{1}{\lim_{g(z) \rightarrow g(z_0)} \frac{f(g(z)) - f(g(z_0))}{g(z) - g(z_0)}} = \frac{1}{f'(g(z_0))}. \quad \square$$

## 2.3 Constant Functions

As an example application of the definition of the derivative of a complex function, we consider functions which have a derivative of 0. One of the first applications of the Mean-Value Theorem for real-valued functions, Theorem 1.18, is to show that if a function has zero derivative everywhere on an interval then it must be constant.

**Lemma 2.13.** *If  $f : I \rightarrow \mathbb{R}$  is a real-valued function with  $f'(x)$  defined and equal to 0 for all  $x \in I$ , then there is a constant  $c \in \mathbb{R}$  such that  $f(x) = c$  for all  $x \in I$ .*

*Proof.* The proof is easy: The Mean-Value Theorem says that for any  $x, y \in I$ ,

$$f(y) - f(x) = f'(x + a(y - x))(y - x)$$

for some  $0 < a < 1$ . If we know that  $f'$  is always zero then we know that  $f'(x + a(y - x)) = 0$ , so the above equation yields  $f(y) = f(x)$ . Since this is true for any  $x, y \in I$ ,  $f$  must be constant.  $\square$

There is a complex version of the Mean-Value Theorem, but we defer its statement to another course. Instead, we will use a different argument to prove that complex functions with derivative that are always 0 must be constant.

Lemma 2.13 required two key features of the function  $f$ , both of which are somewhat obviously necessary. The first is that  $f$  be differentiable everywhere in its domain. In fact, if  $f$  is not differentiable everywhere, we can construct functions which have zero derivative ‘almost’ everywhere but which have infinitely many values in their range.

The second key feature is that the interval  $I$  is connected. It is certainly important for the domain to be connected in both the real and complex cases. For instance, if we define

$$f(z) = \begin{cases} 1 & \text{if } \operatorname{Re} z > 0, \\ -1 & \text{if } \operatorname{Re} z < 0, \end{cases}$$

then  $f'(z) = 0$  for all  $z$  in the domain of  $f$  but  $f$  is not constant. This may seem like a silly example, but it illustrates a pitfall to proving a function is constant that we must be careful of.

Recall that a *region* of  $\mathbb{C}$  is an open connected subset.

**Theorem 2.14.** *If the domain of  $f$  is a region  $G \subseteq \mathbb{C}$  and  $f'(z) = 0$  for all  $z$  in  $G$  then  $f$  is a constant.*

*Proof.* We will show that  $f$  is constant along horizontal segments and along vertical segments in  $G$ . Then, if  $x$  and  $y$  are two points in  $G$  which can be connected by horizontal and vertical segments, we have that  $f(x) = f(y)$ . But any two points of a region may be connected by finitely many such segments by Theorem 1.16, so  $f$  has the same value at any two points of  $G$ , proving the theorem.

To see that  $f$  is constant along horizontal segments, suppose that  $H$  is a horizontal line segment in  $G$ . Since  $H$  is a horizontal segment, there is some value  $y_0 \in \mathbb{R}$  so that the imaginary part of any  $z \in H$  is  $\operatorname{Im}(z) = y_0$ . Consider the real part  $u(z)$  of the function  $f$ . Since  $\operatorname{Im}(z)$  is constant on  $H$ , we can consider  $u(z)$  to be just a function of  $x$ , the real part of  $z = x + iy_0$ . By assumption,  $f'(z) = 0$ , so for  $z \in H$  we have  $u_x(z) = \operatorname{Re}(f'(z)) = 0$ . Thus, by Lemma 2.13,  $u(z)$  is constant on  $H$ . We can argue the same way to see that the imaginary part  $v(z)$  of  $f(z)$  is constant on  $H$ , since  $v_x(z) = \operatorname{Im}(f'(z)) = 0$ . Since both the real and imaginary parts of  $f$  are constant on  $H$ ,  $f$  itself is constant on  $H$ .

This same argument works for vertical segments, interchanging the roles of the real and imaginary parts, so we’re done. □

There are a number of surprising applications of this basic theorem; see Exercises 14 and 15 for a start.

## 2.4 The Cauchy–Riemann Equations

When considering real-valued functions  $f(x, y) : \mathbb{R}^2 \rightarrow \mathbb{R}$  of two variables, there is no notion of ‘the’ derivative of a function. For such functions, we instead only have partial derivatives  $f_x(x, y)$  and  $f_y(x, y)$  (and also directional derivatives) which depend on the way in which we approach a point  $(x, y) \in \mathbb{R}^2$ . For a complex-valued function  $f(z) = f(x, y) : \mathbb{C} \rightarrow \mathbb{R}$ , we now have a new concept of derivative,  $f'(z)$ , which by definition cannot depend on the way in which we approach



a point  $(x, y) \in \mathbb{C}$ . It is logical, then, that there should be a relationship between the complex derivative  $f'(z)$  and the partial derivatives  $\frac{\partial f}{\partial x}(z)$  and  $\frac{\partial f}{\partial y}(z)$  (defined exactly as in the real-valued case). The relationship between the complex derivative and partial derivatives is very strong and is a powerful computational tool. It is described by the Cauchy–Riemann Equations, named after Augustin Louis Cauchy (1789–1857)<sup>1</sup> and Georg Friedrich Bernhard Riemann (1826–1866)<sup>2</sup>, (even though the equations first appeared in the work of Jean le Rond d’Alembert and Euler):

**Theorem 2.15.** (a) *Suppose  $f$  is differentiable at  $z_0 = x_0 + iy_0$ . Then the partial derivatives of  $f$  satisfy*

$$\frac{\partial f}{\partial x}(z_0) = -i \frac{\partial f}{\partial y}(z_0). \quad (2.1)$$

(b) *Suppose  $f$  is a complex function such that the partial derivatives  $f_x$  and  $f_y$  exist in an open disk centered at  $z_0$  and are continuous at  $z_0$ . If these partial derivatives satisfy (2.1) then  $f$  is differentiable at  $z_0$ .*

*In both cases (a) and (b),  $f'$  is given by*

$$f'(z_0) = \frac{\partial f}{\partial x}(z_0).$$

*Remarks.* 1. It is traditional, and often convenient, to write the function  $f$  in terms of its real and imaginary parts. That is, we write  $f(z) = f(x, y) = u(x, y) + iv(x, y)$  where  $u$  is the real part of  $f$  and  $v$  is the imaginary part. Then  $f_x = u_x + iv_x$  and  $-if_y = -i(u_y + iv_y) = v_y - iu_y$ . Using this terminology we can rewrite the equation (2.1) equivalently as the following pair of equations:

$$\begin{aligned} u_x(x_0, y_0) &= v_y(x_0, y_0) \\ u_y(x_0, y_0) &= -v_x(x_0, y_0). \end{aligned} \quad (2.2)$$

2. As stated, (a) and (b) are not quite converse statements. However, we will later show that if  $f$  is *holomorphic* at  $z_0 = x_0 + iy_0$  then  $u$  and  $v$  have continuous partials (of any order) at  $z_0$ . That is, later we will prove that  $f = u + iv$  is holomorphic in an open set  $G$  if and only if  $u$  and  $v$  have continuous partials that satisfy (2.2) in  $G$ .

3. If  $u$  and  $v$  satisfy (2.2) and their second partials are also continuous then we obtain

$$u_{xx}(x_0, y_0) = v_{yx}(x_0, y_0) = v_{xy}(x_0, y_0) = -u_{yy}(x_0, y_0),$$

that is,

$$u_{xx}(x_0, y_0) + u_{yy}(x_0, y_0) = 0$$

and an analogous identity for  $v$ . Functions with continuous second partials satisfying this partial differential equation on a region  $G \subset \mathbb{C}$  (though not necessarily (2.2)) are called *harmonic* on  $G$ ; we will study such functions in Chapter 6. Again, as we will see later, if  $f$  is holomorphic in an open set  $G$  then the partials of any order of  $u$  and  $v$  exist; hence we will show that the real and imaginary part of a function which is holomorphic on an open set are harmonic on that set.

---

<sup>1</sup>For more information about Cauchy, see

<http://www-groups.dcs.st-and.ac.uk/~history/Biographies/Cauchy.html>.

<sup>2</sup>For more information about Riemann, see

<http://www-groups.dcs.st-and.ac.uk/~history/Biographies/Riemann.html>.

*Proof of Theorem 2.15.* (a) If  $f$  is differentiable at  $z_0 = (x_0, y_0)$  then

$$f'(z_0) = \lim_{\Delta z \rightarrow 0} \frac{f(z_0 + \Delta z) - f(z_0)}{\Delta z}.$$

As we saw in the last section we must get the same result if we restrict  $\Delta z$  to be on the real axis and if we restrict it to be on the imaginary axis. In the first case we have  $\Delta z = \Delta x$  and

$$f'(z_0) = \lim_{\Delta x \rightarrow 0} \frac{f(z_0 + \Delta x) - f(z_0)}{\Delta x} = \lim_{\Delta x \rightarrow 0} \frac{f(x_0 + \Delta x, y_0) - f(x_0, y_0)}{\Delta x} = \frac{\partial f}{\partial x}(x_0, y_0).$$

In the second case we have  $\Delta z = i\Delta y$  and

$$f'(z_0) = \lim_{i\Delta y \rightarrow 0} \frac{f(z_0 + i\Delta y) - f(z_0)}{i\Delta y} = \lim_{\Delta y \rightarrow 0} \frac{1}{i} \frac{f(x_0, y_0 + \Delta y) - f(x_0, y_0)}{\Delta y} = -i \frac{\partial f}{\partial y}(x_0, y_0)$$

(using  $\frac{1}{i} = -i$ ). Thus we have shown that  $f'(z_0) = f_x(z_0) = -if_y(z_0)$ .

(b) To prove the statement in (b), “all we need to do” is prove that  $f'(z_0) = f_x(z_0)$ , assuming the Cauchy–Riemann equations and continuity of the partials. We first rearrange a difference quotient for  $f'(z_0)$ , writing  $\Delta z = \Delta x + i\Delta y$ :

$$\begin{aligned} \frac{f(z_0 + \Delta z) - f(z_0)}{\Delta z} &= \frac{f(z_0 + \Delta z) - f(z_0 + \Delta x) + f(z_0 + \Delta x) - f(z_0)}{\Delta z} \\ &= \frac{f(z_0 + \Delta x + i\Delta y) - f(z_0 + \Delta x)}{\Delta z} + \frac{f(z_0 + \Delta x) - f(z_0)}{\Delta z} \\ &= \frac{\Delta y}{\Delta z} \cdot \frac{f(z_0 + \Delta x + i\Delta y) - f(z_0 + \Delta x)}{\Delta y} + \frac{\Delta x}{\Delta z} \cdot \frac{f(z_0 + \Delta x) - f(z_0)}{\Delta x}. \end{aligned}$$

Now we rearrange  $f_x(z_0)$ :

$$\begin{aligned} f_x(z_0) &= \frac{\Delta z}{\Delta z} \cdot f_x(z_0) = \frac{i\Delta y + \Delta x}{\Delta z} \cdot f_x(z_0) = \frac{\Delta y}{\Delta z} \cdot if_x(z_0) + \frac{\Delta x}{\Delta z} \cdot f_x(z_0) \\ &= \frac{\Delta y}{\Delta z} \cdot f_y(z_0) + \frac{\Delta x}{\Delta z} \cdot f_x(z_0), \end{aligned}$$

where we used equation (2.1) in the last step to convert  $if_x$  to  $i(-if_y) = f_y$ . Now we subtract our two rearrangements and take a limit:

$$\begin{aligned} &\lim_{\Delta z \rightarrow 0} \frac{f(z_0 + \Delta z) - f(z_0)}{\Delta z} - f_x(z_0) \\ &= \lim_{\Delta z \rightarrow 0} \left[ \frac{\Delta y}{\Delta z} \left( \frac{f(z_0 + \Delta x + i\Delta y) - f(z_0 + \Delta x)}{\Delta y} - f_y(z_0) \right) \right] \\ &\quad + \lim_{\Delta z \rightarrow 0} \left[ \frac{\Delta x}{\Delta z} \left( \frac{f(z_0 + \Delta x) - f(z_0)}{\Delta x} - f_x(z_0) \right) \right]. \end{aligned} \tag{2.3}$$

We need to show that these limits are both 0. The fractions  $\Delta x/\Delta z$  and  $\Delta y/\Delta z$  are bounded by 1 in modulus so we just need to see that the limits of the expressions in parentheses are 0. The second term in (2.3) has a limit of 0 since, by definition,

$$f_x(z_0) = \lim_{\Delta x \rightarrow 0} \frac{f(z_0 + \Delta x) - f(z_0)}{\Delta x}$$

and taking the limit as  $\Delta z \rightarrow 0$  is the same as taking the limit as  $\Delta x \rightarrow 0$ . We can't do this for the first expression since both  $\Delta x$  and  $\Delta y$  are involved, and both change as  $\Delta z \rightarrow 0$ .

For the first term in (2.3) we apply Theorem 1.18, the real mean-value theorem, to the real and imaginary parts of  $f$ . This gives us real numbers  $a$  and  $b$ , with  $0 < a, b < 1$ , so that

$$\begin{aligned}\frac{u(x_0 + \Delta x, y_0 + \Delta y) - u(x_0 + \Delta x, y_0)}{\Delta y} &= u_y(x_0 + \Delta x, y_0 + a\Delta y) \\ \frac{v(x_0 + \Delta x, y_0 + \Delta y) - v(x_0 + \Delta x, y_0)}{\Delta y} &= v_y(x_0 + \Delta x, y_0 + b\Delta y).\end{aligned}$$

Using these expressions, we have

$$\begin{aligned}\frac{f(z_0 + \Delta x + i\Delta y) - f(z_0 + \Delta x)}{\Delta y} - f_y(z_0) &= u_y(x_0 + \Delta x, y_0 + a\Delta y) + iv_y(x_0 + \Delta x, y_0 + b\Delta y) - (u_y(x_0, y_0) + iv_y(x_0, y_0)) \\ &= (u_y(x_0 + \Delta x, y_0 + a\Delta y) - u_y(x_0, y_0)) + i(v_y(x_0 + \Delta x, y_0 + a\Delta y) - v_y(x_0, y_0)).\end{aligned}$$

Finally, the two differences in parentheses have zero limit as  $\Delta z \rightarrow 0$  because  $u_y$  and  $v_y$  are continuous at  $(x_0, y_0)$ .  $\square$

## Exercises

- Use the definition of limit to show that  $\lim_{z \rightarrow z_0} (az + b) = az_0 + b$ .
- Evaluate the following limits or explain why they don't exist.
  - $\lim_{z \rightarrow i} \frac{iz^3 - 1}{z + i}$ .
  - $\lim_{z \rightarrow 1 - i} x + i(2x + y)$ .
- Prove Lemma 2.4.
- Prove Lemma 2.4 by using the formula for  $f'$  given in Theorem 2.15.
- Apply the definition of the derivative to give a direct proof that  $f'(z) = -\frac{1}{z^2}$  when  $f(z) = \frac{1}{z}$ .
- Show that if  $f$  is differentiable at  $z$  then  $f$  is continuous at  $z$ .
- Prove Lemma 2.6.
- Prove Lemma 2.11.
- Find the derivative of the function  $T(z) := \frac{az+b}{cz+d}$ , where  $a, b, c, d \in \mathbb{C}$  and  $ad - bc \neq 0$ . When is  $T'(z) = 0$ ?
- Prove that if  $f(z)$  is given by a polynomial in  $z$  then  $f$  is entire. What can you say if  $f(z)$  is given by a polynomial in  $x = \operatorname{Re} z$  and  $y = \operatorname{Im} z$ ?
- If  $u(x, y)$  and  $v(x, y)$  are continuous (respectively differentiable) does it follow that  $f(z) = u(x, y) + iv(x, y)$  is continuous (resp. differentiable)? If not, provide a counterexample.

12. Where are the following functions differentiable? Where are they holomorphic? Determine their derivatives at points where they are differentiable.

- (a)  $f(z) = e^{-x}e^{-iy}$ .
- (b)  $f(z) = 2x + ixy^2$ .
- (c)  $f(z) = x^2 + iy^2$ .
- (d)  $f(z) = e^xe^{-iy}$ .
- (e)  $f(z) = \cos x \cosh y - i \sin x \sinh y$ .
- (f)  $f(z) = \operatorname{Im} z$ .
- (g)  $f(z) = |z|^2 = x^2 + y^2$ .
- (h)  $f(z) = z \operatorname{Im} z$ .
- (i)  $f(z) = \frac{ix+1}{y}$ .
- (j)  $f(z) = 4(\operatorname{Re} z)(\operatorname{Im} z) - i(\bar{z})^2$ .
- (k)  $f(z) = 2xy - i(x+y)^2$ .
- (l)  $f(z) = z^2 - \bar{z}^2$ .

13. Consider the function

$$f(z) = \begin{cases} \frac{xy(x+iy)}{x^2+y^2} & \text{if } z \neq 0, \\ 0 & \text{if } z = 0. \end{cases}$$

(As always,  $z = x + iy$ .) Show that  $f$  satisfies the Cauchy–Riemann equations at the origin  $z = 0$ , yet  $f$  is not differentiable at the origin. Why doesn't this contradict Theorem 2.15 (b)?

14. Prove: If  $f$  is holomorphic in the region  $G \subseteq \mathbb{C}$  and always real valued, then  $f$  is constant in  $G$ . (*Hint*: Use the Cauchy–Riemann equations to show that  $f' = 0$ .)

15. Prove: If  $f(z)$  and  $\overline{f(z)}$  are both holomorphic in the region  $G \subseteq \mathbb{C}$  then  $f(z)$  is constant in  $G$ .

16. Suppose that  $f = u + iv$  is holomorphic. Find  $v$  given  $u$ :

- (a)  $u = x^2 + y^2$
- (b)  $u = \cosh y \sin x$
- (c)  $u = 2x^2 + x + 1 - 2y^2$
- (d)  $u = \frac{x}{x^2+y^2}$

17. Suppose  $f(z)$  is entire, with real and imaginary parts  $u(z)$  and  $v(z)$  satisfying  $u(z)v(z) = 3$  for all  $z$ . Show that  $f$  is constant.

18. Is  $\frac{x}{x^2+y^2}$  harmonic on  $\mathbb{C}$ ? What about  $\frac{x^2}{x^2+y^2}$ ?

19. The general real homogeneous quadratic function of  $(x, y)$  is

$$u(x, y) = ax^2 + bxy + cy^2,$$

where  $a$ ,  $b$  and  $c$  are real constants.

- (a) Show that  $u$  is harmonic if and only if  $a = -c$ .
- (b) If  $u$  is harmonic then show that it is the real part of a function of the form  $f(z) = Az^2$ , where  $A$  is a complex constant. Give a formula for  $A$  in terms of the constants  $a$ ,  $b$  and  $c$ .

## Chapter 3

# Examples of Functions

*Obvious is the most dangerous word in mathematics.*  
E. T. Bell

### 3.1 Möbius Transformations

The first class of functions that we will discuss in some detail are built from linear polynomials.

**Definition 3.1.** A *linear fractional transformation* is a function of the form

$$f(z) = \frac{az + b}{cz + d},$$

where  $a, b, c, d \in \mathbb{C}$ . If  $ad - bc \neq 0$  then  $f$  is called a *Möbius<sup>1</sup> transformation*.

Exercise 10 of the previous chapter states that any polynomial (in  $z$ ) is an entire function. From this fact we can conclude that a linear fractional transformation  $f(z) = \frac{az+b}{cz+d}$  is holomorphic in  $\mathbb{C} \setminus \{-\frac{d}{c}\}$  (unless  $c = 0$ , in which case  $f$  is entire).

One property of Möbius transformations, which is quite special for complex functions, is the following.

**Lemma 3.2.** *Möbius transformations are bijections. In fact, if  $f(z) = \frac{az+b}{cz+d}$  then the inverse function of  $f$  is given by*

$$f^{-1}(z) = \frac{dz - b}{-cz + a}.$$

*Remark.* Notice that the inverse of a Möbius transformation is another Möbius transformation.

*Proof.* Note that  $f : \mathbb{C} \setminus \{-\frac{d}{c}\} \rightarrow \mathbb{C} \setminus \{\frac{a}{c}\}$ . Suppose  $f(z_1) = f(z_2)$ , that is,

$$\frac{az_1 + b}{cz_1 + d} = \frac{az_2 + b}{cz_2 + d}.$$

As the denominators are nonzero, this is equivalent to

$$(az_1 + b)(cz_2 + d) = (az_2 + b)(cz_1 + d),$$

---

<sup>1</sup>Named after August Ferdinand Möbius (1790–1868). For more information about Möbius, see <http://www-groups.dcs.st-and.ac.uk/~history/Biographies/Mobius.html>.

which can be rearranged to

$$(ad - bc)(z_1 - z_2) = 0.$$

Since  $ad - bc \neq 0$  this implies that  $z_1 = z_2$ , which means that  $f$  is one-to-one. The formula for  $f^{-1} : \mathbb{C} \setminus \{\frac{a}{c}\} \rightarrow \mathbb{C} \setminus \{-\frac{d}{c}\}$  can be checked easily. Just like  $f$ ,  $f^{-1}$  is one-to-one, which implies that  $f$  is onto.  $\square$

Aside from being prime examples of one-to-one functions, Möbius transformations possess fascinating geometric properties. En route to an example of such, we introduce some terminology. Special cases of Möbius transformations are *translations*  $f(z) = z + b$ , *dilations*  $f(z) = az$ , and *inversions*  $f(z) = \frac{1}{z}$ . The next result says that if we understand those three special transformations, we understand them all.

**Proposition 3.3.** *Suppose  $f(z) = \frac{az+b}{cz+d}$  is a linear fractional transformation. If  $c = 0$  then*

$$f(z) = \frac{a}{d}z + \frac{b}{d},$$

*if  $c \neq 0$  then*

$$f(z) = \frac{bc - ad}{c^2} \frac{1}{z + \frac{d}{c}} + \frac{a}{c}.$$

*In particular, every linear fractional transformation is a composition of translations, dilations, and inversions.*

*Proof.* Simplify.  $\square$

With the last result at hand, we can tackle the promised theorem about the following geometric property of Möbius transformations.

**Theorem 3.4.** *Möbius transformations map circles and lines into circles and lines.*

*Proof.* Translations and dilations certainly map circles and lines into circles and lines, so by the last proposition, we only have to prove the theorem for the inversion  $f(z) = \frac{1}{z}$ .

Before going on we find a standard form for the equation of a straight line. Starting with  $ax + by = c$  (where  $z = x + iy$ ), let  $\alpha = a + bi$ . Then  $\bar{\alpha}z = ax + by + i(ay - bx)$  so  $\bar{\alpha}z + \alpha\bar{z} = \bar{\alpha}z + \overline{\bar{\alpha}z} = 2\operatorname{Re}(\bar{\alpha}z) = 2ax + 2by$ . Hence our standard equation for a line becomes

$$\bar{\alpha}z + \alpha\bar{z} = 2c, \quad \text{or} \quad \operatorname{Re}(\bar{\alpha}z) = c. \quad (3.1)$$

*Circle case:* Given a circle centered at  $z_0$  with radius  $r$ , we can modify its defining equation  $|z - z_0| = r$  as follows:

$$\begin{aligned} |z - z_0|^2 &= r^2 \\ (z - z_0)\overline{(z - z_0)} &= r^2 \\ z\bar{z} - z_0\bar{z} - z\bar{z}_0 + z_0\bar{z}_0 &= r^2 \\ |z|^2 - z_0\bar{z} - z\bar{z}_0 + |z_0|^2 - r^2 &= 0. \end{aligned}$$

Now we want to transform this into an equation in terms of  $w$ , where  $w = \frac{1}{z}$ . If we solve  $w = \frac{1}{z}$  for  $z$  we get  $z = \frac{1}{w}$ , so we make this substitution in our equation:

$$\begin{aligned} \left| \frac{1}{w} \right|^2 - z_0 \frac{1}{w} - \overline{z_0} \frac{1}{w} + |z_0|^2 - r^2 &= 0 \\ 1 - z_0 w - \overline{z_0} \overline{w} + |w|^2 (|z_0|^2 - r^2) &= 0. \end{aligned}$$

(To get the second line we multiply by  $|w|^2 = w\overline{w}$  and simplify.) Now if  $r$  happens to be equal to  $|z_0|^2$  then this equation becomes  $1 - z_0 w - \overline{z_0} \overline{w} = 0$ , which is of the form (3.1) with  $\alpha = \overline{z_0}$ , so we have a straight line in terms of  $w$ . Otherwise  $|z_0|^2 - r^2$  is non-zero so we can divide our equation by it. We obtain

$$|w|^2 - \frac{z_0}{|z_0|^2 - r^2} w - \frac{\overline{z_0}}{|z_0|^2 - r^2} \overline{w} + \frac{1}{|z_0|^2 - r^2} = 0.$$

We define

$$w_0 = \frac{\overline{z_0}}{|z_0|^2 - r^2}, \quad s^2 = |w_0|^2 - \frac{1}{|z_0|^2 - r^2} = \frac{|z_0|^2}{(|z_0|^2 - r^2)^2} - \frac{|z_0|^2 - r^2}{(|z_0|^2 - r^2)^2} = \frac{r^2}{(|z_0|^2 - r^2)^2}.$$

Then we can rewrite our equation as

$$\begin{aligned} |w|^2 - \overline{w_0} w - w_0 \overline{w} + |w_0|^2 - s^2 &= 0 \\ w\overline{w} - w_0 \overline{w} - w \overline{w_0} + w_0 \overline{w_0} &= s^2 \\ (w - w_0) \overline{(w - w_0)} &= s^2 \\ |w - w_0|^2 &= s^2. \end{aligned}$$

This is the equation of a circle in terms of  $w$ , with center  $w_0$  and radius  $s$ .

*Line case:* We start with the equation of a line in the form (3.1) and rewrite it in terms of  $w$ , as above, by substituting  $z = \frac{1}{w}$  and simplifying. We get

$$\overline{z_0} \overline{w} + z_0 w = 2cw\overline{w}.$$

If  $c = 0$ , this describes a line in the form (3.1) in terms of  $w$ . Otherwise we can divide by  $2c$ :

$$\begin{aligned} w\overline{w} - \frac{\overline{z_0}}{2c} \overline{w} - \frac{z_0}{2c} w &= 0 \\ \left( w - \frac{\overline{z_0}}{2c} \right) \left( \overline{w} - \frac{z_0}{2c} \right) - \frac{|z_0|^2}{4c^2} &= 0 \\ \left| w - \frac{\overline{z_0}}{2c} \right|^2 &= \frac{|z_0|^2}{4c^2}. \end{aligned}$$

This is the equation of a circle with center  $\frac{\overline{z_0}}{2c}$  and radius  $\frac{|z_0|}{2|c|}$ . □

There is one fact about Möbius transformations that is very helpful to understanding their geometry. In fact, it is much more generally useful:



**Lemma 3.5.** *Suppose  $f$  is holomorphic at  $a$  with  $f'(a) \neq 0$  and suppose  $\gamma_1$  and  $\gamma_2$  are two smooth curves which pass through  $a$ , making an angle of  $\theta$  with each other. Then  $f$  transforms  $\gamma_1$  and  $\gamma_2$  into smooth curves which meet at  $f(a)$ , and the transformed curves make an angle of  $\theta$  with each other.*

In brief, an holomorphic function with non-zero derivative *preserves angles*. Functions which preserve angles in this way are also called *conformal*.

*Proof.* For  $k = 1, 2$  we write  $\gamma_k$  parametrically, as  $z_k(t) = x_k(t) + iy_k(t)$ , so that  $z_k(0) = a$ . The complex number  $z'_k(0)$ , considered as a vector, is the tangent vector to  $\gamma_k$  at the point  $a$ . Then  $f$  transforms the curve  $\gamma_k$  to the curve  $f(\gamma_k)$ , parameterized as  $f(z_k(t))$ . If we differentiate  $f(z_k(t))$  at  $t = 0$  and use the chain rule we see that the tangent vector to the transformed curve at the point  $f(a)$  is  $f'(a)z'_k(0)$ . Since  $f'(a) \neq 0$  the transformation from  $z'_1(0)$  and  $z'_2(0)$  to  $f'(a)z'_1(0)$  and  $f'(a)z'_2(0)$  is a dilation. A dilation is the composition of a scale change and a rotation and both of these preserve the angles between vectors.  $\square$

## 3.2 Infinity and the Cross Ratio

Infinity is not a number—this is true whether we use the complex numbers or stay in the reals. However, for many purposes we can work with infinity in the complexes much more naturally and simply than in the reals.

In the complex sense there is only one infinity, written  $\infty$ . In the real sense there is also a “negative infinity”, but  $-\infty = \infty$  in the complex sense. In order to deal correctly with infinity we have to realize that we are always talking about a limit, and complex numbers have infinite limits if they can become larger in magnitude than any preassigned limit. For completeness we repeat the usual definitions:

**Definition 3.6.** Suppose  $G$  is a set of complex numbers and  $f$  is a function from  $G$  to  $\mathbb{C}$ .

- (a)  $\lim_{z \rightarrow z_0} f(z) = \infty$  means that for every  $M > 0$  we can find  $\delta > 0$  so that, for all  $z \in G$  satisfying  $0 < |z - z_0| < \delta$ , we have  $|f(z)| > M$ .
- (b)  $\lim_{z \rightarrow \infty} f(z) = L$  means that for every  $\epsilon > 0$  we can find  $N > 0$  so that, for all  $z \in G$  satisfying  $|z| > N$ , we have  $|f(z) - L| < \epsilon$ .
- (c)  $\lim_{z \rightarrow \infty} f(z) = \infty$  means that for every  $M > 0$  we can find  $N > 0$  so that, for all  $z \in G$  satisfying  $|z| > N$  we have  $|f(z)| > M$ .

In the first definition we require that  $z_0$  is an accumulation point of  $G$  while in the second and third we require that  $\infty$  is an “extended accumulation point” of  $G$ , in the sense that for every  $B > 0$  there is some  $z \in G$  with  $|z| > B$ .

The usual rules for working with infinite limits are still valid in the complex numbers. In fact, it is a good idea to make infinity an honorary complex number so that we can more easily manipulate infinite limits. We then define algebraic rules for dealing with our new point,  $\infty$ , based on the usual laws of limits. For example, if  $\lim_{z \rightarrow z_0} f(z) = \infty$  and  $\lim_{z \rightarrow z_0} g(z) = a$  is finite then the usual “limit of

sum = sum of limits” rule gives  $\lim_{z \rightarrow z_0} (f(z) + g(z)) = \infty$ . This leads us to want the rule  $\infty + a = \infty$ .

We do this by defining a new set,  $\hat{\mathbb{C}}$ :

**Definition 3.7.** The *extended complex plane* is the set  $\hat{\mathbb{C}} := \mathbb{C} \cup \{\infty\}$ , together with the following algebraic properties: For any  $a \in \mathbb{C}$ ,

- (1)  $\infty + a = a + \infty = \infty$
- (2) if  $a \neq 0$  then  $\infty \cdot a = a \cdot \infty = \infty \cdot \infty = \infty$
- (3) if  $a \neq 0$  then  $\frac{a}{\infty} = 0$  and  $\frac{a}{0} = \infty$

The extended complex plane is also called the *Riemann sphere* (or, in a more advanced course, the *complex projective line*, denoted  $\mathbb{C}\mathbb{P}^1$ ).

If a calculation involving infinity is not covered by the rules above then we must investigate the limit more carefully. For example, it may seem strange that  $\infty + \infty$  is not defined, but if we take the limit of  $z + (-z) = 0$  as  $z \rightarrow \infty$  we will get 0, but the individual limits of  $z$  and  $-z$  are both  $\infty$ .

Now we reconsider Möbius transformations with infinity in mind. For example,  $f(z) = \frac{1}{z}$  is now defined for  $z = 0$  and  $z = \infty$ , with  $f(0) = \infty$  and  $f(\infty) = 0$ , so the proper domain for  $f(z)$  is actually  $\hat{\mathbb{C}}$ . Let’s consider the other basic types of Möbius transformations. A translation  $f(z) = z + b$  is now defined for  $z = \infty$ , with  $f(\infty) = \infty + b = \infty$ , and a dilation  $f(z) = az$  (with  $a \neq 0$ ) is also defined for  $z = \infty$ , with  $f(\infty) = a \cdot \infty = \infty$ . Since every Möbius transformation can be expressed as a composition of translations, dilations and the inversion  $f(z) = \frac{1}{z}$  we see that every Möbius transformation may be interpreted as a transformation of  $\hat{\mathbb{C}}$  onto  $\hat{\mathbb{C}}$ . The general case is summarized below:

**Lemma 3.8.** *Let  $f$  be the Möbius transformation*

$$f(z) = \frac{az + b}{cz + d}.$$

*Then  $f$  is defined for all  $z \in \hat{\mathbb{C}}$ . If  $c = 0$  then  $f(\infty) = \infty$ , and, otherwise,*

$$f(\infty) = \frac{a}{c} \quad \text{and} \quad f\left(-\frac{d}{c}\right) = \infty.$$

With this interpretation in mind we can add some insight to Theorem 3.4. Recall that  $f(z) = \frac{1}{z}$  transforms circles that pass through the origin to straight lines, but the point  $z = 0$  must be excluded from the circle. However, now we can put it back, so  $f$  transforms circles that pass through the origin to straight lines *plus*  $\infty$ . If we remember that  $\infty$  corresponds to being arbitrarily far away from the origin we can visualize a line plus infinity as a circle passing through  $\infty$ . If we make this a definition then Theorem 3.4 can be expressed very simply: any Möbius transformation of  $\hat{\mathbb{C}}$  transforms circles to circles. For example, the transformation

$$f(z) = \frac{z + i}{z - i}$$

transforms  $-i$  to 0,  $i$  to  $\infty$ , and 1 to  $i$ . The three points  $-i$ ,  $i$  and 1 determine a circle—the unit circle  $|z| = 1$ —and the three image points 0,  $\infty$  and  $i$  also determine a circle—the imaginary axis

plus the point at infinity. Hence  $f$  transforms the unit circle onto the imaginary axis plus the point at infinity.

This example relied on the idea that three distinct points in  $\hat{\mathbb{C}}$  determine uniquely a circle passing through them. If the three points are on a straight line or if one of the points is  $\infty$  then the circle is a straight line plus  $\infty$ . Conversely, if we know where three distinct points in  $\hat{\mathbb{C}}$  are transformed by a Möbius transformation then we should be able to figure out everything about the transformation. There is a computational device that makes this easier to see.

**Definition 3.9.** If  $z, z_1, z_2,$  and  $z_3$  are any four points in  $\hat{\mathbb{C}}$  with  $z_1, z_2,$  and  $z_3$  distinct, then their *cross-ratio* is defined by

$$[z, z_1, z_2, z_3] = \frac{(z - z_1)(z_2 - z_3)}{(z - z_3)(z_2 - z_1)}.$$

Here if  $z = z_3$ , the result is infinity, and if one of  $z, z_1, z_2,$  or  $z_3$  is infinity, then the two terms on the right containing it are canceled.

**Lemma 3.10.** If  $f$  is defined by  $f(z) = [z, z_1, z_2, z_3]$  then  $f$  is a Möbius transformation which satisfies

$$f(z_1) = 0, \quad f(z_2) = 1, \quad f(z_3) = \infty.$$

Moreover, if  $g$  is any Möbius transformation which transforms  $z_1, z_2$  and  $z_3$  as above then  $g(z) = f(z)$  for all  $z$ .

*Proof.* Everything should be clear except the final uniqueness statement. By Lemma 3.2 the inverse  $f^{-1}$  is a Möbius transformation and, by Exercise 7 in this chapter, the composition  $h = g \circ f^{-1}$  is a Möbius transformation. Notice that  $h(0) = g(f^{-1}(0)) = g(z_1) = 0$ . Similarly,  $h(1) = 1$  and  $h(\infty) = \infty$ . If we write  $h(z) = \frac{az+b}{cz+d}$  then

$$\begin{aligned} 0 = h(0) &= \frac{b}{d} \implies b = 0 \\ \infty = h(\infty) &= \frac{a}{c} \implies c = 0 \\ 1 = h(1) &= \frac{a+b}{c+d} = \frac{a+0}{0+d} = \frac{a}{d} \implies a = d, \end{aligned}$$

so  $h(z) = \frac{az+b}{cz+d} = \frac{az+0}{0+d} = \frac{a}{d}z = z$ . But since  $h(z) = z$  for all  $z$  we have  $h(f(z)) = f(z)$  and so  $g(z) = g \circ (f^{-1} \circ f)(z) = (g \circ f^{-1}) \circ f(z) = h(f(z)) = f(z)$ .  $\square$

So if we want to map three given points of  $\hat{\mathbb{C}}$  to 0, 1 and  $\infty$  by a Möbius transformation then the cross-ratio gives us the only way to do it. What if we have three points  $z_1, z_2$  and  $z_3$  and we want to map them to three other points,  $w_1, w_2$  and  $w_3$ ?

**Theorem 3.11.** Suppose  $z_1, z_2$  and  $z_3$  are distinct points in  $\hat{\mathbb{C}}$  and  $w_1, w_2$  and  $w_3$  are distinct points in  $\hat{\mathbb{C}}$ . Then there is a unique Möbius transformation  $h$  satisfying  $h(z_1) = w_1, h(z_2) = w_2$  and  $h(z_3) = w_3$ .

*Proof.* Let  $h = g^{-1} \circ f$  where  $f(z) = [z, z_1, z_2, z_3]$  and  $g(w) = [w, w_1, w_2, w_3]$ . Uniqueness follows as in the proof of Lemma 3.10.  $\square$

This theorem gives an explicit way to determine  $h$  from the points  $z_j$  and  $w_j$  but, in practice, it is often easier to determine  $h$  directly from the conditions  $f(z_k) = w_k$  (by solving for  $a, b, c$  and  $d$ ).

### 3.3 Stereographic Projection

The addition of  $\infty$  to the complex plane  $\mathbb{C}$  gives the plane a very useful structure. This structure is revealed by a famous function called stereographic projection. Stereographic projection also gives us a way of visualizing the extended complex plane – that is, the point at infinity – in  $\mathbb{R}^3$ , as the unit sphere. It also provides a way of ‘seeing’ that a line in the extended complex plane is really a circle, and of visualizing Möbius functions.

To begin, think of  $\mathbb{C}$  as the  $xy$ -plane in  $\mathbb{R}^3 = \{(x, y, z)\}$ ,  $\mathbb{C} = \{(x, y, 0) \in \mathbb{R}^3\}$ . To describe stereographic projection, we will be less concerned with actual complex numbers  $x + iy$  and more with their coordinates. Consider the unit sphere  $\mathbb{S}^2 := \{(x, y, z) \in \mathbb{R}^3 | x^2 + y^2 + z^2 = 1\}$ . Then the sphere and the complex plane intersect in the set  $\{(x, y, 0) | x^2 + y^2 = 1\}$ , corresponding to the equator on the sphere and the unit circle on the complex plane. Let  $N$  denote the North Pole  $(0, 0, 1)$  of  $\mathbb{S}^2$ , and let  $S$  denote the South Pole  $(0, 0, -1)$ .

**Definition 3.12.** The *stereographic projection of  $\mathbb{S}^2$  to  $\hat{\mathbb{C}}$  from  $N$*  is the map  $\phi: \mathbb{S}^2 \rightarrow \hat{\mathbb{C}}$  defined as follows. For any point  $P \in \mathbb{S}^2 - \{N\}$ , as the  $z$ -coordinate of  $P$  is strictly less than 1, the line  $\overleftrightarrow{NP}$  intersects  $\mathbb{C}$  in exactly one point,  $Q$ . Define  $\phi(P) := Q$ . We also declare that  $\phi(N) = \infty \in \mathbb{C}$ .

**Proposition 3.13.** *The map  $\phi$  is the bijection*

$$\phi(x, y, z) = \left( \frac{x}{1-z}, \frac{y}{1-z}, 0 \right),$$

with inverse map

$$\phi^{-1}(p, q, 0) = \left( \frac{2p}{p^2 + q^2 + 1}, \frac{2q}{p^2 + q^2 + 1}, \frac{p^2 + q^2 - 1}{p^2 + q^2 + 1} \right),$$

where we declare  $\phi(0, 0, 1) = \infty$  and  $\phi^{-1}(\infty) = (0, 0, 1)$ .

*Proof.* That  $\phi$  is a bijection follows from the existence of the inverse function, and is left as an exercise. For  $P = (x, y, z) \in \mathbb{S}^2 - \{N\}$ , the straight line  $\overleftrightarrow{NP}$  through  $N$  and  $P$  is given by, for  $t \in \mathbb{R}$ ,

$$r(t) = N + t(P - N) = (0, 0, 1) + t[(x, y, z) - (0, 0, 1)] = (tx, ty, 1 + t(z - 1)).$$

When  $r(t)$  hits  $\mathbb{C}$ , the third coordinate is 0, so it must be that  $t = \frac{1}{1-z}$ . Plugging this value of  $t$  into the formula for  $r$  yields  $\phi$  as stated.

To see the formula for the inverse map  $\phi^{-1}$ , we begin with a point  $Q = (p, q, 0) \in \mathbb{C}$ , and solve for a point  $P = (x, y, z) \in \mathbb{S}^2$  so that  $\phi(P) = Q$ . The point  $P$  satisfies the equation  $x^2 + y^2 + z^2 = 1$ . The equation  $\phi(P) = Q$  tells us that  $\frac{x}{1-z} = p$  and  $\frac{y}{1-z} = q$ . Thus, we solve 3 equations for 3 unknowns. The latter two equations yield

$$p^2 + q^2 = \frac{x^2 + y^2}{(1-z)^2} = \frac{1-z^2}{(1-z)^2} = \frac{1+z}{1-z}.$$

Solving  $p^2 + q^2 = \frac{1+z}{1-z}$  for  $z$ , and then plugging this into the identities  $x = p(1-z)$  and  $y = q(1-z)$  proves the desired formula. It is easy to check that  $\phi \circ \phi^{-1}$  and  $\phi^{-1} \circ \phi$  are now both the identity; we leave these as exercises. This proves the proposition.  $\square$

We use the formulas above to prove the following.

**Theorem 3.14.** *The stereographic projection  $\phi$  takes the set of circles in  $\mathbb{S}^2$  bijectively to the set of circles in  $\hat{\mathbb{C}}$ , where for a circle  $\gamma \subset \mathbb{S}^2$  we have that  $\infty \in \phi(\gamma)$  – that is,  $\phi(\gamma)$  is a line in  $\mathbb{C}$  – if and only if  $N \in \gamma$ .*

*Proof.* A circle in  $\mathbb{S}^2$  is the intersection of  $\mathbb{S}^2$  with some plane  $P$ . If we have a normal vector  $(x_0, y_0, z_0)$  to  $P$ , then there is a unique real number  $k$  so that the plane  $P$  is given by

$$P = \{(x, y, z) \in \mathbb{R}^3 \mid (x, y, z) \cdot (x_0, y_0, z_0) = k\} = \{(x, y, z) \in \mathbb{R}^3 \mid xx_0 + yy_0 + zz_0 = k\}.$$

Without loss of generality, we can assume that  $(x_0, y_0, z_0) \in \mathbb{S}^2$  by possibly changing  $k$ . We may also assume without loss of generality that  $0 \leq k \leq 1$ , since if  $k < 0$  we can replace  $(x_0, y_0, z_0)$  with  $-(x_0, y_0, z_0)$ , and if  $k > 1$  then  $P \cap \mathbb{S}^2 = \emptyset$ .

Consider the circle of intersection  $P \cap \mathbb{S}^2$ . A point  $(p, q, 0)$  in the complex plane lies on the image of this circle under  $\phi$  if and only if  $\phi^{-1}(p, q, 0)$  satisfies the defining equation for  $P$ . Using the equations from Proposition 3.13 for  $\phi^{-1}(p, q, 0)$ , we see that

$$(z_0 - k)p^2 + (2x_0)p + (z_0 - k)q^2 + (2y_0)q = z_0 + k.$$

If  $z_0 - k = 0$ , this is a straight line in the  $pq$ -plane. Moreover, every line in the  $pq$ -plane can be obtained in this way. Notice that  $z_0 = k$  if and only if  $N \in P$ , which is if and only if the image under  $\phi$  is a straight line.

If  $z_0 - k \neq 0$ , then completing the square yields

$$\left(p + \frac{x_0}{z_0 - k}\right)^2 + \left(q + \frac{y_0}{z_0 - k}\right)^2 = \frac{1 - k^2}{(z_0 - k)^2}.$$

Depending on whether the right hand side of this equation is positive, 0, or negative, this is the equation of a circle, point, or the empty set in the  $pq$ -plane, respectively. These three cases happen when  $k < 1$ ,  $k = 1$ , and  $k > 1$ , respectively. Only the first case corresponds to a circle in  $\mathbb{S}^2$ . It is an exercise to verify that every circle in the  $pq$ -plane arises in this manner.  $\square$

We can now think of the extended complex plane as a sphere in  $\mathbb{R}^3$ , called the *Riemann sphere*.

It is particularly nice to think about the basic Möbius transformations via their effect on the Riemann sphere. We will describe inversion. It is worth thinking about, though beyond the scope of these notes, how other basic Möbius functions behave. For instance, a rotation  $f(z) = e^{i\theta}z$ , composed with  $\phi^{-1}$ , can be seen to be a rotation of  $\mathbb{S}^2$ . We encourage the reader to verify this to themselves, and consider the harder problems of visualizing a real dilation  $f(z) = rz$  or a translation,  $f(z) = z + b$ . We give the hint that a real dilation is in some sense ‘dual’ to a rotation, in that each moves points ‘along’ perpendicular sets of circles. Translations can also be visualized via how they move points ‘along’ sets of circles.

We now use stereographic projection to take another look at  $f(z) = 1/z$ . We want to know what this function does to the sphere  $\mathbb{S}^2$ . We will take an  $(x, y, z)$  on  $\mathbb{S}^2$ , project it to the plane by stereographic projection  $\phi$ , apply  $f$  to the point that results, and then pull this point back to  $\mathbb{S}^2$  by  $\phi^{-1}$ .

We know  $\phi(x, y, z) = (x/(1 - z), y/(1 - z))$  which we now regard as the complex number

$$\frac{x}{1 - z} + i\frac{y}{1 - z}.$$

We use

$$\frac{1}{p + qi} = \frac{p - qi}{p^2 + q^2}.$$

We know from a previous calculation that  $p^2 + q^2 = (1 + z)/(1 - z)$ . This gives

$$f\left(\frac{x}{1-z} + i\frac{y}{1-z}\right) = \left(\frac{x}{1-z} - i\frac{y}{1-z}\right) \left(\frac{1-z}{1+z}\right) = \frac{x}{1+z} + i\frac{-y}{1+z}.$$

Rather than plug this result into the formulas for  $\phi^{-1}$ , we can just ask what triple of numbers will go to this particular pair using the formulas  $\phi(x, y, z) = (x/(1-z), y/(1-z))$ . The answer is clearly  $(x, -y, -z)$ .

Thus we have shown that the effect of  $f(z) = 1/z$  on  $\mathbb{S}^2$  is to take  $(x, y, z)$  to  $(x, -y, -z)$ . This is a rotation around the  $x$ -axis by 180 degrees.

We now have a second argument that  $f(z) = 1/z$  takes circles and lines to circles and lines. A circle or line in  $\mathbb{C}$  is taken to a circle on  $\mathbb{S}^2$  by  $\phi^{-1}$ . Then  $1/z$  rotates the sphere which certainly takes circles to circles. Now  $\phi$  takes circles back to circles and lines. We can also say that the circles that go to lines under  $f(z) = 1/z$  are the circles through 0. This is because 0 goes to  $(0, 0, -1)$  under  $\phi^{-1}$  so a circle through 0 in  $\mathbb{C}$  goes to a circle through the south pole in  $\mathbb{S}^2$ . Now 180 rotation about the  $x$ -axis takes the south pole to the north pole, and our circle is now passing through  $N$ . But we know that  $\phi$  will take this circle to a line in  $\mathbb{C}$ .

We end by mentioning that there is in fact a way of putting the complex metric on  $\mathbb{S}^2$ . It is certainly not the (finite) distance function induced by  $\mathbb{R}^3$ . Indeed, the origin in the complex plane corresponds to the South Pole  $S$  of  $\mathbb{S}^2$ . We have to be able to get arbitrarily far away from the origin in  $\mathbb{C}$ , so the complex distance function has to increase greatly with the  $z$  coordinate. The closer points are to the North Pole  $N$  (corresponding to  $\infty$  in  $\hat{\mathbb{C}}$ ), the *larger* their distance to the origin, and to each other! In this light, a ‘line’ in the Riemann sphere  $\mathbb{S}^2$  corresponds to a circle in  $\mathbb{S}^2$  through  $N$ . In the regular sphere, the circle has finite length, but as a line on the Riemann sphere with the complex metric, it has infinite length.

### 3.4 Exponential and Trigonometric Functions

To define the complex exponential function, we once more borrow concepts from calculus, namely the real exponential function<sup>2</sup> and the real sine and cosine, and—in addition—finally make sense of the notation  $e^{it} = \cos t + i \sin t$ .

**Definition 3.15.** The (*complex*) *exponential function* is defined for  $z = x + iy$  as

$$\exp(z) = e^x (\cos y + i \sin y) = e^x e^{iy}.$$

This definition seems a bit arbitrary, to say the least. Its first justification is that all exponential rules which we are used to from real numbers carry over to the complex case. They mainly follow from Lemma 1.4 and are collected in the following.

---

<sup>2</sup>It is a nontrivial question how to define the real exponential function. Our preferred way to do this is through a power series:  $e^x = \sum_{k \geq 0} x^k/k!$ . In light of this definition, the reader might think we should have simply defined the complex exponential function through a complex power series. In fact, this is possible (and an elegant definition); however, one of the promises of these lecture notes is to introduce complex power series as late as possible. We agree with those readers who think that we are “cheating” at this point, as we borrow the concept of a (real) power series to define the real exponential function.

**Lemma 3.16.** For all  $z, z_1, z_2 \in \mathbb{C}$ ,

(a)  $\exp(z_1)\exp(z_2) = \exp(z_1 + z_2)$

(b)  $\frac{1}{\exp(z)} = \exp(-z)$

(c)  $\exp(z + 2\pi i) = \exp(z)$

(d)  $|\exp(z)| = \exp(\operatorname{Re} z)$

(e)  $\exp(z) \neq 0$

(f)  $\frac{d}{dz} \exp(z) = \exp(z)$ .

*Remarks.* 1. The third identity is a very special one and has no counterpart for the real exponential function. It says that the complex exponential function is *periodic* with period  $2\pi i$ . This has many interesting consequences; one that may not seem too pleasant at first sight is the fact that the complex exponential function is not one-to-one.

2. The last identity is not only remarkable, but we invite the reader to meditate on its proof. When proving this identity through the Cauchy–Riemann equations for the exponential function, one can get another strong reason why Definition 3.15 is reasonable. Finally, note that the last identity also says that  $\exp$  is entire.

We should make sure that the complex exponential function specializes to the real exponential function for real arguments: if  $z = x \in \mathbb{R}$  then

$$\exp(x) = e^x (\cos 0 + i \sin 0) = e^x.$$

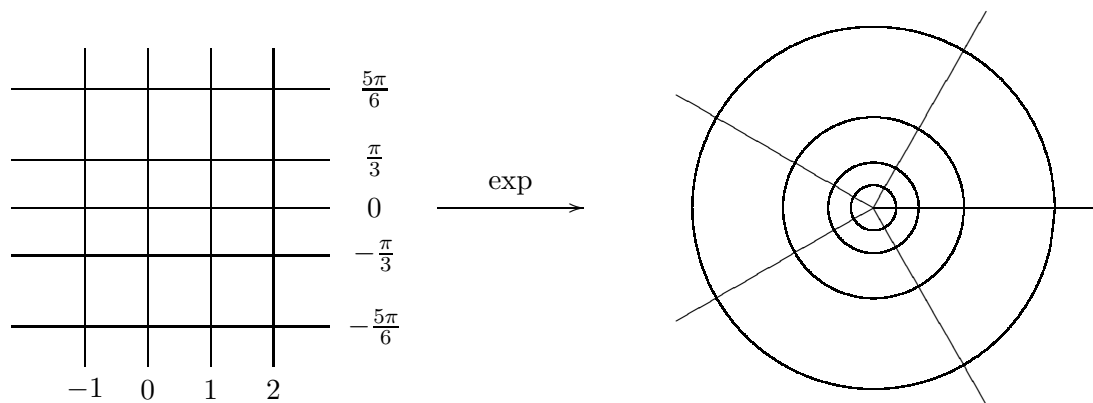

Figure 3.1: Image properties of the exponential function.

The trigonometric functions—sine, cosine, tangent, cotangent, etc.—have their complex analogues, however, they don’t play the same prominent role as in the real case. In fact, we can define them as merely being special combinations of the exponential function.

**Definition 3.17.** The (*complex*) *sine* and *cosine* are defined as

$$\sin z = \frac{1}{2i} (\exp(iz) - \exp(-iz)) \quad \text{and} \quad \cos z = \frac{1}{2} (\exp(iz) + \exp(-iz)),$$

respectively. The *tangent* and *cotangent* are defined as

$$\tan z = \frac{\sin z}{\cos z} = -i \frac{\exp(2iz) - 1}{\exp(2iz) + 1} \quad \text{and} \quad \cot z = \frac{\cos z}{\sin z} = i \frac{\exp(2iz) + 1}{\exp(2iz) - 1},$$

respectively.

Note that to write tangent and cotangent in terms of the exponential function, we used the fact that  $\exp(z)\exp(-z) = \exp(0) = 1$ . Because  $\exp$  is entire, so are  $\sin$  and  $\cos$ .

As with the exponential function, we should first make sure that we're not redefining the real sine and cosine: if  $z = x \in \mathbb{R}$  then

$$\sin z = \frac{1}{2i} (\exp(ix) - \exp(-ix)) = \frac{1}{2i} (\cos x + i \sin x - (\cos(-x) + i \sin(-x))) = \sin x.$$

A similar calculation holds for the cosine. Not too surprisingly, the following properties follow mostly from Lemma 3.16.

**Lemma 3.18.** For all  $z, z_1, z_2 \in \mathbb{C}$ ,

$$\begin{array}{ll} \sin(-z) = -\sin z & \cos(-z) = \cos z \\ \sin(z + 2\pi) = \sin z & \cos(z + 2\pi) = \cos z \\ \tan(z + \pi) = \tan z & \cot(z + \pi) = \cot z \\ \sin(z + \pi/2) = \cos z & \cos(z + \pi/2) = -\sin z \\ \sin(z_1 + z_2) = \sin z_1 \cos z_2 + \cos z_1 \sin z_2 & \cos(z_1 + z_2) = \cos z_1 \cos z_2 - \sin z_1 \sin z_2 \\ \cos^2 z + \sin^2 z = 1 & \cos^2 z - \sin^2 z = \cos(2z) \\ \sin' z = \cos z & \cos' z = -\sin z. \end{array}$$

Finally, one word of caution: unlike in the real case, the complex sine and cosine are *not* bounded—consider, for example,  $\sin(iy)$  as  $y \rightarrow \pm\infty$ .

We end this section with a remark on hyperbolic trig functions. The hyperbolic sine, cosine, tangent, and cotangent are defined as in the real case:

**Definition 3.19.**

$$\begin{array}{ll} \sinh z = \frac{1}{2} (\exp(z) - \exp(-z)) & \cosh z = \frac{1}{2} (\exp(z) + \exp(-z)) \\ \tanh z = \frac{\sinh z}{\cosh z} = \frac{\exp(2z) - 1}{\exp(2z) + 1} & \coth z = \frac{\cosh z}{\sinh z} = \frac{\exp(2z) + 1}{\exp(2z) - 1}. \end{array}$$

As such, they are also special combinations of the exponential function. They still satisfy the identities you already know, including

$$\frac{d}{dz} \sinh z = \cosh z \quad \frac{d}{dz} \cosh z = \sinh z.$$

Moreover, they are now related to the trigonometric functions via the following useful identities:

$$\sinh(iz) = i \sin z \quad \text{and} \quad \cosh(iz) = \cos z.$$



### 3.5 The Logarithm and Complex Exponentials

The complex logarithm is the first function we'll encounter that is of a somewhat tricky nature. It is motivated as being the inverse function to the exponential function, that is, we're looking for a function  $\mathcal{L}og$  such that

$$\exp(\mathcal{L}og z) = z = \mathcal{L}og(\exp z).$$

As we will see shortly, this is too much to hope for. Let's write, as usual,  $z = r e^{i\phi}$ , and suppose that  $\mathcal{L}og z = u(z) + iv(z)$ . Then for the first equation to hold, we need

$$\exp(\mathcal{L}og z) = e^u e^{iv} = r e^{i\phi} = z,$$

that is,  $e^u = r = |z| \iff u = \ln |z|$  (where  $\ln$  denotes the real natural logarithm; in particular we need to demand that  $z \neq 0$ ), and  $e^{iv} = e^{i\phi} \iff v = \phi + 2\pi k$  for some  $k \in \mathbb{Z}$ . A reasonable definition of a logarithm function  $\mathcal{L}og$  would hence be to set  $\mathcal{L}og z = \ln |z| + i \mathcal{A}rg z$  where  $\mathcal{A}rg z$  gives the argument for the complex number  $z$  according to some convention—for example, we could agree that the argument is always in  $(-\pi, \pi]$ , or in  $[0, 2\pi)$ , etc. The problem is that we need to stick to this convention. On the other hand, as we saw, we could just use a different argument convention and get another reasonable 'logarithm.' Even worse, by defining the multi-valued map

$$\arg z = \{\phi : \phi \text{ is a possible argument of } z\}$$

and defining the multi-valued logarithm as

$$\log z = \ln |z| + i \arg z,$$

we get something that's not a function, yet it satisfies

$$\exp(\log z) = z.$$

We invite the reader to check this thoroughly; in particular, one should note how the periodicity of the exponential function takes care of the multi-valuedness of our 'logarithm'  $\log$ .

$\log$  is, of course, not a function, and hence we can't even consider it to be our sought-after inverse of the exponential function. Let's try to make things well defined.

**Definition 3.20.** Any function  $\mathcal{L}og : \mathbb{C} \setminus \{0\} \rightarrow \mathbb{C}$  which satisfies  $\exp(\mathcal{L}og z) = z$  is a *branch of the logarithm*. Let  $\mathcal{A}rg z$  denote that argument of  $z$  which is in  $(-\pi, \pi]$  (the *principal argument* of  $z$ ). Then the *principal logarithm* is defined as

$$\mathcal{L}og z = \ln |z| + i \mathcal{A}rg z.$$

The paragraph preceding this definition ensures that the principal logarithm is indeed a branch of the logarithm. Even better, the evaluation of any branch of the logarithm at  $z$  can only differ from  $\mathcal{L}og z$  by a multiple of  $2\pi i$ ; the reason for this is once more the periodicity of the exponential function.

So what about the other equation  $\mathcal{L}og(\exp z) = z$ ? Let's try the principal logarithm: Suppose  $z = x + iy$ , then

$$\mathcal{L}og(\exp z) = \mathcal{L}og(e^x e^{iy}) = \ln |e^x e^{iy}| + i \mathcal{A}rg(e^x e^{iy}) = \ln e^x + i \mathcal{A}rg(e^{iy}) = x + i \mathcal{A}rg(e^{iy}).$$

The right-hand side is equal to  $z = x + iy$  only if  $y \in (-\pi, \pi]$ . The same happens with any other branch of the logarithm  $\mathcal{L}\text{og}$ —there will always be some (in fact, many)  $y$ -values for which  $\mathcal{L}\text{og}(\exp z) \neq z$ .

To end our discussion of the logarithm on a happy note, we prove that *any* branch of the logarithm has the *same* derivative; one just has to be cautious about where each logarithm is holomorphic.

**Theorem 3.21.** *Suppose  $\mathcal{L}\text{og}$  is a branch of the logarithm. Then  $\mathcal{L}\text{og}$  is differentiable wherever it is continuous and*

$$\mathcal{L}\text{og}' z = \frac{1}{z}.$$

*Proof.* The idea is to apply Lemma 2.12 to  $\exp$  and  $\mathcal{L}\text{og}$ , but we need to be careful about the domains of these functions, so that we get actual inverse functions. Suppose  $\mathcal{L}\text{og}$  maps  $\mathbb{C} \setminus \{0\}$  to  $G$  (this is typically a half-open strip; you might want to think about what it looks like if  $\mathcal{L}\text{og} = \text{Log}$ ). We apply Lemma 2.12 with  $f : G \rightarrow \mathbb{C} \setminus \{0\}$ ,  $f(z) = \exp(z)$  and  $g : \mathbb{C} \setminus \{0\} \rightarrow G$ ,  $g(z) = \mathcal{L}\text{og}$ : if  $\mathcal{L}\text{og}$  is continuous at  $z$  then

$$\mathcal{L}\text{og}' z = \frac{1}{\exp'(\mathcal{L}\text{og} z)} = \frac{1}{\exp(\mathcal{L}\text{og} z)} = \frac{1}{z}. \quad \square$$

We finish this section by defining complex exponentials. For two complex numbers  $a$  and  $b$ , the natural definition  $a^b = \exp(b \log a)$  (which is a concept borrowed from calculus) would in general yield more than one value (Exercise 42), so it is not always useful. We turn instead to the principal logarithm:

**Definition 3.22.** For a complex number  $a \in \mathbb{C}$ , the *exponential function with base  $a$*  is the multi-valued function

$$a^x := \exp(b \log a).$$

The *principal value* of  $a^x$  at  $x$  (unfortunately) uses the same notation, and is defined as

$$a^x := \exp(x \text{Log} a).$$

When we write  $a^x$  we are referring to the principal value unless otherwise stated.

It now makes sense to talk about the *exponential function with base  $e$* . In calculus one proves the equivalence of the real exponential function (as given, for example, through a power series) and the function  $f(x) = e^x$  where  $e$  is *Euler's<sup>3</sup> number* and can be defined, for example, as  $e = \lim_{n \rightarrow \infty} \left(1 + \frac{1}{n}\right)^n$ . With our definition of  $a^x$ , we can now make a similar remark about the complex exponential function. Because  $e$  is a positive real number and hence  $\text{Arg} e = 0$ , we obtain

$$e^z = \exp(z \text{Log} e) = \exp(z(\ln |e| + i \text{Arg} e)) = \exp(z \ln e) = \exp(z).$$

A word of caution: this only works out this nicely because we have now carefully defined  $a^x$  for complex numbers. Different definitions will make it so that  $e^z \neq \exp(z)$ !

---

<sup>3</sup>Named after Leonard Euler (1707–1783). For more information about Euler, see <http://www-groups.dcs.st-and.ac.uk/~history/Biographies/Euler.html>.

## Exercises

1. Show that if  $f(z) = \frac{az+b}{cz+d}$  is a Möbius transformation then  $f^{-1}(z) = \frac{dz-b}{-cz+a}$ .
2. Show that the derivative of a Möbius transformation is never zero.
3. Prove that any Möbius transformation different from the identity map can have at most two fixed points. (A *fixed point* of a function  $f$  is a number  $z$  such that  $f(z) = z$ .)
4. Prove Proposition 3.3.
5. Show that the Möbius transformation  $f(z) = \frac{1+z}{1-z}$  maps the unit circle (minus the point  $z = 1$ ) onto the imaginary axis.
6. Suppose that  $f$  is holomorphic on the region  $G$  and  $f(G)$  is a subset of the unit circle. Show that  $f$  is constant. (*Hint*: Consider the function  $\frac{1+f(z)}{1-f(z)}$  and use Exercise 5 and a variation of Exercise 14 in Chapter 2.)
7. Suppose  $A = \begin{bmatrix} a & b \\ c & d \end{bmatrix}$  is a  $2 \times 2$  matrix of complex numbers whose determinant  $ad - bc$  is non-zero. Then we can define a corresponding Möbius transformation  $T_A$  by  $T_A(z) = \frac{az+b}{cz+d}$ . Show that  $T_A \circ T_B = T_{A \cdot B}$ . (Here  $\circ$  denotes composition and  $\cdot$  denotes matrix multiplication.)
8. Let  $f(z) = \frac{2z}{z+2}$ . Draw two graphs, one showing the following six sets in the  $z$  plane and the other showing their images in the  $w$  plane. Label the sets. (You should only need to calculate the images of  $0, \pm 2, \infty$  and  $-1 - i$ ; remember that Möbius transformations preserve angles.)
  - (a) The  $x$ -axis, plus  $\infty$ .
  - (b) The  $y$ -axis, plus  $\infty$ .
  - (c) The line  $x = y$ , plus  $\infty$ .
  - (d) The circle with radius 2 centered at 0.
  - (e) The circle with radius 1 centered at 1.
  - (f) The circle with radius 1 centered at  $-1$ .
9. Find Möbius transformations satisfying each of the following. Write your answers in standard form, as  $\frac{az+b}{cz+d}$ .
  - (a)  $1 \rightarrow 0, 2 \rightarrow 1, 3 \rightarrow \infty$ . (Use the cross-ratio.)
  - (b)  $1 \rightarrow 0, 1+i \rightarrow 1, 2 \rightarrow \infty$ . (Use the cross-ratio.)
  - (c)  $0 \rightarrow i, 1 \rightarrow 1, \infty \rightarrow -i$ .
10. Let  $C$  be the circle with center  $1+i$  and radius 1. Using the cross-ratio, with different choices of  $z_k$ , find two different Möbius transformations that transform  $C$  onto the real axis plus infinity. In each case, find the image of the center of the circle.
11. Let  $C$  be the circle with center 0 and radius 1. Find a Möbius transformation which transforms  $C$  onto  $C$  and transforms 0 to  $\frac{1}{2}$ .

12. Describe the image of the region under the transformation:
- The disk  $|z| < 1$  under  $w = \frac{iz-i}{z+1}$ .
  - The quadrant  $x > 0, y > 0$  under  $w = \frac{z-i}{z+i}$ .
  - The strip  $0 < x < 1$  under  $w = \frac{z}{z-1}$ .
13. The *Jacobian* of a transformation  $u = u(x, y), v = v(x, y)$  is the determinant of the matrix  $\begin{bmatrix} \frac{\partial u}{\partial x} & \frac{\partial u}{\partial y} \\ \frac{\partial v}{\partial x} & \frac{\partial v}{\partial y} \end{bmatrix}$ . Show that if  $f = u + iv$  is holomorphic then the Jacobian equals  $|f'(z)|^2$ .
14. Find the fixed points in  $\hat{\mathbb{C}}$  of  $f(z) = \frac{z^2-1}{2z+1}$ .
15. Find the Möbius transformation  $f$ :
- $f$  maps  $0 \rightarrow 1, 1 \rightarrow \infty, \infty \rightarrow 0$ .
  - $f$  maps  $1 \rightarrow 1, -1 \rightarrow i, -i \rightarrow -1$ .
  - $f$  maps  $x$ -axis to  $y = x, y$ -axis to  $y = -x$ , and the unit circle to itself.
16. Show that the image of the line  $y = a$  under inversion is the circle with center  $\frac{-i}{2a}$  and radius  $\frac{1}{2a}$ .
17. Suppose  $z_1, z_2$  and  $z_3$  are distinct points in  $\hat{\mathbb{C}}$ . Show that  $z$  is on the circle passing through  $z_1, z_2$  and  $z_3$  if and only if  $[z, z_1, z_2, z_3]$  is real or infinite.
18. Find the image under the stereographic projection  $\phi$  of the following points:  $(0, 0, -1), (0, 0, 1), (1, 0, 0), (0, 1, 0), (1, 1, 0)$ .
19. Prove that the stereographic projection of Proposition 3.13 is a bijection by verifying that that  $\phi \circ \phi^{-1}$  and  $\phi^{-1} \circ \phi$  are the identity.
20. Consider the plane  $P$  determined by  $x + y - z = 0$ . What is a unit normal vector to  $P$ ? Compute the image of  $P \cap S^2$  under the stereographic projection  $\phi$ .
21. Prove that every circle in the extended complex plane is the image of some circle in  $S^2$  under the stereographic projection  $\phi$ .
22. Describe the effect of the basic Möbius transformations rotation, real dilation, and translation on the Riemann sphere. *hint: for the first two, consider all circles in  $S^2$  centered on the NS axis, and all circles through both N and S. For translation, consider two families of circles through N, 'orthogonal' to and 'perpendicular' to the translation.*
23. Prove that  $\overline{\sin(z)} = \sin(\bar{z})$  and  $\overline{\cos(z)} = \cos(\bar{z})$ .
24. Prove that  $\sin(x+iy) = \sin x \cosh y + i \cos x \sinh y$ , and  $\cos(x+iy) = \cos x \cosh y - i \sin x \sinh y$ .
25. Prove that the zeros of  $\sin z$  are all real-valued.
26. Describe the images of the following sets under the exponential function  $\exp(z)$ :

- (a) the line segment defined by  $z = iy$ ,  $0 \leq y \leq 2\pi$ .
- (b) the line segment defined by  $z = 1 + iy$ ,  $0 \leq y \leq 2\pi$ .
- (c) the rectangle  $\{z = x + iy \in \mathbb{C} : 0 \leq x \leq 1, 0 \leq y \leq 2\pi\}$ .
27. Prove Lemma 3.16.
28. Prove Lemma 3.18.
29. Let  $z = x + iy$  and show that
- (a)  $\sin z = \sin x \cosh y + i \cos x \sinh y$ .
- (b)  $\cos z = \cos x \cosh y - i \sin x \sinh y$ .
30. Let  $z = x + iy$  and show that
- (a)  $|\sin z|^2 = \sin^2 x + \sinh^2 y = \cosh^2 y - \cos^2 x$ .
- (b)  $|\cos z|^2 = \cos^2 x + \sinh^2 y = \cosh^2 y - \sin^2 x$ .
- (c) If  $\cos x = 0$  then  $|\cot z|^2 = \frac{\cosh^2 y - 1}{\cosh^2 y} \leq 1$ .
- (d) If  $|y| \geq 1$  then  $|\cot z|^2 \leq \frac{\sinh^2 y + 1}{\sinh^2 y} = 1 + \frac{1}{\sinh^2 y} \leq 1 + \frac{1}{\sinh^2 1} \leq 2$ .
31. Show that  $\tan(iz) = i \tanh z$ .
32. Evaluate the value(s) of the following expressions, giving your answers in the form  $x + iy$ .
- (a)  $e^{i\pi}$
- (b)  $e^\pi$
- (c)  $i^i$
- (d)  $e^{\sin i}$
- (e)  $\exp(\text{Log}(3 + 4i))$
- (f)  $\sqrt{1 + i}$
- (g)  $\sqrt{31 - i}$
- (h)  $\left(\frac{i+1}{\sqrt{2}}\right)^4$
33. Find the principal values of
- (a)  $\log i$ .
- (b)  $(-1)^i$ .
- (c)  $\log(1 + i)$ .
34. Determine the image of the strip  $\{z \in \mathbb{C} : -\pi/2 < \text{Re } z < \pi/2\}$  under the function  $f(z) = \sin z$ .
35. Is  $\arg(\bar{z}) = -\arg(z)$  true for the multiple-valued argument? What about  $\text{Arg}(\bar{z}) = -\text{Arg}(z)$  for the principal branch?

36. Is there a difference between the set of all values of  $\log(z^2)$  and the set of all values of  $2\log z$ ? (Try some fixed numbers for  $z$ .)
37. For each of the following functions, determine all complex numbers for which the function is holomorphic. If you run into a logarithm, use the principal value (unless stated otherwise).
- $\bar{z}^2$ .
  - $\frac{\sin z}{z^3+1}$ .
  - $\mathcal{L}\log(z-2i+1)$  where  $\mathcal{L}\log(z) = \ln|z| + i\mathcal{A}\text{rg}(z)$  with  $0 \leq \mathcal{A}\text{rg}(z) < 2\pi$ .
  - $\exp(\bar{z})$ .
  - $(z-3)^i$ .
  - $iz^{-3}$ .
38. Find all solutions to the following equations:
- $\text{Log}(z) = \frac{\pi}{2}i$ .
  - $\text{Log}(z) = \frac{3\pi}{2}i$ .
  - $\exp(z) = \pi i$ .
  - $\sin z = \cosh 4$ .
  - $\cos z = 0$ .
  - $\sinh z = 0$ .
  - $\overline{\exp(iz)} = \exp(i\bar{z})$ .
  - $z^{1/2} = 1+i$ .
39. Find the image of the annulus  $1 < |z| < e$  under the principal value of the logarithm.
40. Show that  $|a^z| = a^{\text{Re}z}$  if  $a$  is a positive real constant.
41. Fix  $c \in \mathbb{C} \setminus \{0\}$ . Find the derivative of  $f(z) = z^c$ .
42. Prove that  $\exp(b \log a)$  is single-valued if and only if  $b$  is an integer. (Note that this means that complex exponentials don't clash with monomials  $z^n$ .) What can you say if  $b$  is rational?
43. Describe the image under  $\exp$  of the line with equation  $y = x$ . To do this you should find an equation (at least parametrically) for the image (you can start with the parametric form  $x = t, y = t$ ), plot it reasonably carefully, and explain what happens in the limits as  $t \rightarrow \infty$  and  $t \rightarrow -\infty$ .
44. For this problem,  $f(z) = z^2$ .
- Show that the image of a circle centered at the origin is a circle centered at the origin.
  - Show that the image of a ray starting at the origin is a ray starting at the origin.
  - Let  $T$  be the figure formed by the horizontal segment from 0 to 2, the circular arc from 2 to  $2i$ , and then the vertical segment from  $2i$  to 0. Draw  $T$  and  $f(T)$ .
  - Is the right angle at the origin in part (c) preserved? Is something wrong here?

(*Hint*: Use polar coordinates.)

45. As in the previous problem, let  $f(z) = z^2$ . Let  $Q$  be the square with vertices at  $0$ ,  $2$ ,  $2 + 2i$  and  $2i$ . Draw  $f(Q)$  and identify the types of image curves corresponding to the segments from  $2$  to  $2 + 2i$  and from  $2 + 2i$  to  $2i$ . They are not parts of either straight lines or circles. (*Hint*: You can write the vertical segment parametrically as  $z(t) = 2 + it$ . Eliminate the parameter in  $u + iv = f(z(t))$  to get a  $(u, v)$  equation for the image curve.)

# Chapter 4

## Integration

*Everybody knows that mathematics is about miracles, only mathematicians have a name for them: theorems.*

Roger Howe

### 4.1 Definition and Basic Properties

We begin integration by focusing on ‘1-dimensional’ integrals over lines. We delay discussion of antiderivatives until Chapter 5.

At first sight, complex integration is not really anything different from real integration. For a continuous complex-valued function  $\phi : [a, b] \subset \mathbb{R} \rightarrow \mathbb{C}$ , we define

$$\int_a^b \phi(t) dt = \int_a^b \operatorname{Re} \phi(t) dt + i \int_a^b \operatorname{Im} \phi(t) dt. \quad (4.1)$$

For a function which takes complex numbers as arguments, we integrate over a curve  $\gamma$  (instead of a real interval). Suppose this curve is parametrized by  $\gamma(t)$ ,  $a \leq t \leq b$ . If one meditates about the substitution rule for real integrals, the following definition, which is based on (4.1) should come as no surprise.

**Definition 4.1.** Suppose  $\gamma$  is a smooth curve parametrized by  $\gamma(t)$ ,  $a \leq t \leq b$ , and  $f$  is a complex function which is continuous on  $\gamma$ . Then we define the *integral of  $f$  on  $\gamma$*  as

$$\int_{\gamma} f = \int_{\gamma} f(z) dz = \int_a^b f(\gamma(t))\gamma'(t) dt.$$

This definition can be naturally extended to *piecewise smooth* curves, that is, those curves  $\gamma$  whose parametrization  $\gamma(t)$ ,  $a \leq t \leq b$ , is only piecewise differentiable, say  $\gamma(t)$  is differentiable on the intervals  $[a, c_1], [c_1, c_2], \dots, [c_{n-1}, c_n], [c_n, b]$ . In this case we simply define

$$\int_{\gamma} f = \int_a^{c_1} f(\gamma(t))\gamma'(t) dt + \int_{c_1}^{c_2} f(\gamma(t))\gamma'(t) dt + \dots + \int_{c_n}^b f(\gamma(t))\gamma'(t) dt.$$

In what follows, we’ll usually state our results for smooth curves, bearing in mind that practically all can be extended to piecewise smooth curves.



**Example 4.2.** As our first example of the application of this definition we will compute the integral of the function  $f(z) = \bar{z}^2 = (x^2 - y^2) - i(2xy)$  over several curves from the point  $z = 0$  to the point  $z = 1 + i$ .

- (a) Let  $\gamma$  be the line segment from  $z = 0$  to  $z = 1 + i$ . A parametrization of this curve is  $\gamma(t) = t + it$ ,  $0 \leq t \leq 1$ . We have  $\gamma'(t) = 1 + i$  and  $f(\gamma(t)) = (t - it)^2$ , and hence

$$\int_{\gamma} f = \int_0^1 (t - it)^2 (1 + i) dt = (1 + i) \int_0^1 t^2 - 2it^2 - t^2 dt = -2i(1 + i)/3 = \frac{2}{3}(1 - i).$$

- (b) Let  $\gamma$  be the arc of the parabola  $y = x^2$  from  $z = 0$  to  $z = 1 + i$ . A parametrization of this curve is  $\gamma(t) = t + it^2$ ,  $0 \leq t \leq 1$ . Now we have  $\gamma'(t) = 1 + 2it$  and

$$f(\gamma(t)) = (t^2 - (t^2)^2) - i2t \cdot t^2 = t^2 - t^4 - 2it^3,$$

whence

$$\int_{\gamma} f = \int_0^1 (t^2 - t^4 - 2it^3) (1 + 2it) dt = \int_0^1 t^2 + 3t^4 - 2it^5 dt = \frac{1}{3} + 3\frac{1}{5} - 2i\frac{1}{6} = \frac{14}{15} - \frac{i}{3}.$$

- (c) Let  $\gamma$  be the union of the two line segments  $\gamma_1$  from  $z = 0$  to  $z = 1$  and  $\gamma_2$  from  $z = 1$  to  $z = 1 + i$ . Parameterizations are  $\gamma_1(t) = t$ ,  $0 \leq t \leq 1$  and  $\gamma_2(t) = 1 + it$ ,  $0 \leq t \leq 1$ . Hence

$$\begin{aligned} \int_{\gamma} f &= \int_{\gamma_1} f + \int_{\gamma_2} f = \int_0^1 t^2 \cdot 1 dt + \int_0^1 (1 - it)^2 i dt = \frac{1}{3} + i \int_0^1 1 - 2it - t^2 dt \\ &= \frac{1}{3} + i \left( 1 - 2i\frac{1}{2} - \frac{1}{3} \right) = \frac{4}{3} + \frac{2}{3}i. \end{aligned}$$

The complex integral has some standard properties, most of which follow from their real siblings in a straightforward way. To state some of its properties, we first define the useful concept of the length of a curve.

**Definition 4.3.** The *length* of a smooth curve  $\gamma$  is

$$\text{length}(\gamma) := \int_a^b |\gamma'(t)| dt$$

for any parametrization  $\gamma(t)$ ,  $a \leq t \leq b$ , of  $\gamma$ .

The definition of length is with respect to any parametrization of  $\gamma$  because, as we will see, the length of a curve is independent of the parametrization. We invite the reader to use some familiar curves to see that this definition gives what one would expect to be the length of a curve.

**Proposition 4.4.** Suppose  $\gamma$  is a smooth curve,  $f$  and  $g$  are complex functions which are continuous on  $\gamma$ , and  $c \in \mathbb{C}$ .

- (a)  $\int_{\gamma} (f + cg) = \int_{\gamma} f + c \int_{\gamma} g$ .

- (b) If  $\gamma$  is parametrized by  $\gamma(t)$ ,  $a \leq t \leq b$ , define the curve  $-\gamma$  through  $-\gamma(t) = \gamma(a + b - t)$ ,  $a \leq t \leq b$ . Then  $\int_{-\gamma} f = -\int_{\gamma} f$ .
- (c) If  $\gamma_1$  and  $\gamma_2$  are curves so that  $\gamma_2$  starts where  $\gamma_1$  ends then define the curve  $\gamma_1\gamma_2$  by following  $\gamma_1$  to its end, and then continuing on  $\gamma_2$  to its end. Then  $\int_{\gamma_1\gamma_2} f = \int_{\gamma_1} f + \int_{\gamma_2} f$ .
- (d)  $\left| \int_{\gamma} f \right| \leq \max_{z \in \gamma} |f(z)| \cdot \text{length}(\gamma)$ .

The curve  $-\gamma$  defined in (b) is the curve that we obtain by traveling through  $\gamma$  in the opposite direction.

*Proof.*

- (a) This follows directly from the definition of the integral and the properties of real integrals.
- (b) This follows with an easy real change of variables  $s = a + b - t$ :

$$\begin{aligned} \int_{-\gamma} f &= \int_a^b f(\gamma(a + b - t)) (\gamma(a + b - t))' dt = - \int_a^b f(\gamma(a + b - t)) \gamma'(a + b - t) dt \\ &= \int_b^a f(\gamma(s)) \gamma'(s) ds = - \int_a^b f(\gamma(s)) \gamma'(s) ds = - \int_{\gamma} f. \end{aligned}$$

- (c) We need a suitable parameterization  $\gamma(t)$  for  $\gamma_1\gamma_2$ . If  $\gamma_1$  has domain  $[a_1, b_1]$  and  $\gamma_2$  has domain  $[a_2, b_2]$  then we can use

$$\gamma(t) = \begin{cases} \gamma_1(t) & \text{for } a_1 \leq t \leq b_1, \\ \gamma_2(t - b_1 + a_2) & \text{for } b_1 \leq t \leq b_1 + b_2 - a_2. \end{cases}$$

The fact that  $\gamma_1(b_1) = \gamma_2(a_2)$  is necessary to make sure that this parameterization is piecewise smooth. Now we break the integral over  $\gamma_1\gamma_2$  into two pieces and apply the simple change of variables  $s = t - b_1 + a_2$ :

$$\begin{aligned} \int_{\gamma_1\gamma_2} f &= \int_{a_1}^{b_1 + b_2 - a_2} f(\gamma(t)) \gamma'(t) dt \\ &= \int_{a_1}^{b_1} f(\gamma(t)) \gamma'(t) dt + \int_{b_1}^{b_1 + b_2 - a_2} f(\gamma(t)) \gamma'(t) dt \\ &= \int_{a_1}^{b_1} f(\gamma_1(t)) \gamma_1'(t) dt + \int_{b_1}^{b_1 + b_2 - a_2} f(\gamma_2(t - b_1 + a_2)) \gamma_2'(t - b_1 + a_2) dt \\ &= \int_{a_1}^{b_1} f(\gamma_1(t)) \gamma_1'(t) dt + \int_{a_2}^{b_2} f(\gamma_2(s)) \gamma_2'(s) ds \\ &= \int_{\gamma_1} f + \int_{\gamma_2} f. \end{aligned}$$

(d) To prove (d), let  $\phi = \text{Arg} \int_{\gamma} f$ . Then

$$\begin{aligned} \left| \int_{\gamma} f \right| &= e^{-i\phi} \left( \int_{\gamma} f \right) = \text{Re} \left( e^{-i\phi} \left( \int_a^b f(\gamma(t)) \gamma'(t) dt \right) \right) = \int_a^b \text{Re} \left( f(\gamma(t)) e^{-i\phi} \gamma'(t) \right) dt \\ &\leq \int_a^b \left| f(\gamma(t)) e^{-i\phi} \gamma'(t) \right| dt = \int_a^b |f(\gamma(t))| |\gamma'(t)| dt \\ &\leq \max_{a \leq t \leq b} |f(\gamma(t))| \int_a^b |\gamma'(t)| dt = \max_{z \in \gamma} |f(z)| \cdot \text{length}(\gamma). \quad \square \end{aligned}$$

## 4.2 Cauchy's Theorem

We now turn to the central theorem of complex analysis. It is based on the following concept.

**Definition 4.5.** A curve  $\gamma \subset \mathbb{C}$  is *closed* if its endpoints coincide, i.e. for any parametrization  $\gamma(t)$ ,  $a \leq t \leq b$ , we have that  $\gamma(a) = \gamma(b)$ .

Suppose  $\gamma_0$  and  $\gamma_1$  are closed curves in the open set  $G \subseteq \mathbb{C}$ , parametrized by  $\gamma_0(t)$ ,  $0 \leq t \leq 1$  and  $\gamma_1(t)$ ,  $0 \leq t \leq 1$ , respectively. Then  $\gamma_0$  is *G-homotopic* to  $\gamma_1$ , in symbols  $\gamma_0 \sim_G \gamma_1$ , if there is a continuous function  $h : [0, 1]^2 \rightarrow G$  such that

$$\begin{aligned} h(t, 0) &= \gamma_0(t), \\ h(t, 1) &= \gamma_1(t), \\ h(0, s) &= h(1, s). \end{aligned}$$

The function  $h(t, s)$  is called a *homotopy* and represents a curve for each fixed  $s$ , which is continuously transformed from  $\gamma_0$  to  $\gamma_1$ . The last condition simply says that each of the curves  $h(t, s)$ ,  $0 \leq t \leq 1$  is closed. An example is depicted in Figure 4.1.

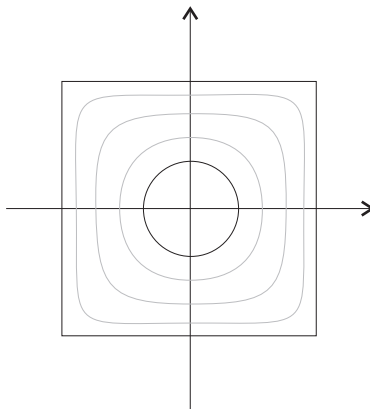

Figure 4.1: This square and the circle are  $(\mathbb{C} \setminus \{0\})$ -homotopic.

Here is the theorem on which most of what will follow is based.

**Theorem 4.6** (Cauchy’s Theorem). *Suppose  $G \subseteq \mathbb{C}$  is open,  $f$  is holomorphic in  $G$ , and  $\gamma_0 \sim_G \gamma_1$  via a homotopy with continuous second partials. Then*

$$\int_{\gamma_0} f = \int_{\gamma_1} f.$$

*Remarks.* 1. The condition on the smoothness of the homotopy can be omitted, however, then the proof becomes too advanced for the scope of these notes. In all the examples and exercises that we’ll have to deal with here, the homotopies will be ‘nice enough’ to satisfy the condition of this theorem.

2. It is assumed that Johann Carl Friedrich Gauß (1777–1855)<sup>1</sup> knew a version of this theorem in 1811 but only published it in 1831. Cauchy published his version in 1825, Weierstraß<sup>2</sup> his in 1842. Cauchy’s theorem is often called the Cauchy–Goursat Theorem, since Cauchy assumed that the derivative of  $f$  was continuous, a condition which was first removed by Goursat<sup>3</sup>.

An important special case is the one where a curve  $\gamma$  is  $G$ -homotopic to a point, that is, a constant curve (see Figure 4.2 for an example). In this case we simply say  $\gamma$  is  $G$ -contractible, in symbols  $\gamma \sim_G 0$ .

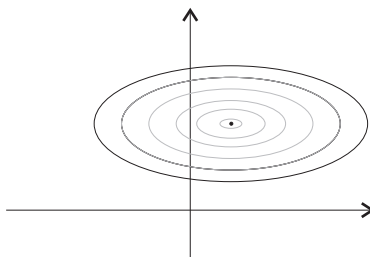

Figure 4.2: This ellipse is  $(\mathbb{C} \setminus \mathbb{R})$ -contractible.

The fact that an integral over a point is zero has the following immediate consequence.

**Corollary 4.7.** *Suppose  $G \subseteq \mathbb{C}$  is open,  $f$  is holomorphic in  $G$ , and  $\gamma \sim_G 0$  via a homotopy with continuous second partials. Then*

$$\int_{\gamma} f = 0.$$

The fact that any closed curve is  $\mathbb{C}$ -contractible (Exercise 18a) yields the following special case of the previous special-case corollary.

**Corollary 4.8.** *If  $f$  is entire and  $\gamma$  is any smooth closed curve then*

$$\int_{\gamma} f = 0.$$

---

<sup>1</sup>For more information about Gauß, see

<http://www-groups.dcs.st-and.ac.uk/~history/Biographies/Gauss.html>.

<sup>2</sup>For more information about Karl Theodor Wilhelm Weierstraß (1815–1897), see <http://www-groups.dcs.st-and.ac.uk/~history/Biographies/Weierstrass.html>.

<sup>3</sup>For more information about Edouard Jean-Baptiste Goursat (1858–1936), see <http://www-groups.dcs.st-and.ac.uk/~history/Biographies/Goursat.html>.

There are many proofs of Cauchy's Theorem. A particularly nice one follows from the complex Green's Theorem. We will use the (real) Second Fundamental Theorem of Calculus. We note that with more work, Cauchy's Theorem can be derived 'from scratch', and does not require any other major theorems.

*Proof of Theorem 4.6.* Suppose  $h$  is the given homotopy from  $\gamma_0$  to  $\gamma_1$ . For  $0 \leq s \leq 1$ , let  $\gamma_s$  be the curve parametrized by  $h(t, s)$ ,  $0 \leq t \leq 1$ . Consider the function

$$I(s) = \int_{\gamma_s} f$$

as a function in  $s$  (so  $I(0) = \int_{\gamma_0} f$  and  $I(1) = \int_{\gamma_1} f$ ). We will show that  $I$  is constant with respect to  $s$ , and hence the statement of the theorem follows with  $I(0) = I(1)$ . Consider the derivative of  $I$ . By Leibniz's Rule,

$$\frac{d}{ds}I(s) = \frac{d}{ds} \int_0^1 f(h(t, s)) \frac{\partial h}{\partial t} dt = \int_0^1 \frac{\partial}{\partial s} \left( f(h(t, s)) \frac{\partial h}{\partial t} \right) dt.$$

By the product rule, the chain rule, and equality of mixed partials,

$$\begin{aligned} \frac{d}{ds}I(s) &= \int_0^1 f'(h(t, s)) \frac{\partial h}{\partial s} \frac{\partial h}{\partial t} + f(h(t, s)) \frac{\partial^2 h}{\partial s \partial t} dt \\ &= \int_0^1 f'(h(t, s)) \frac{\partial h}{\partial t} \frac{\partial h}{\partial s} + f(h(t, s)) \frac{\partial^2 h}{\partial t \partial s} dt \\ &= \int_0^1 \frac{\partial}{\partial t} \left( f(h(t, s)) \frac{\partial h}{\partial s} \right) dt \end{aligned}$$

Finally, by the Fundamental Theorem of Calculus (applied separately to the real and imaginary parts of the above integral), we have:

$$\frac{d}{dx}I(s) = f(h(1, s)) \frac{\partial h}{\partial s}(1, s) - f(h(0, s)) \frac{\partial h}{\partial s}(0, s) = 0.$$

□

### 4.3 Cauchy's Integral Formula

Cauchy's Theorem 4.6 yields almost immediately the following helpful result.

**Theorem 4.9** (Cauchy's Integral Formula for a Circle). *Let  $C_R$  be the counterclockwise circle with radius  $R$  centered at  $w$  and suppose  $f$  is holomorphic at each point of the closed disk  $D$  bounded by  $C_R$ . Then*

$$f(w) = \frac{1}{2\pi i} \int_{C_R} \frac{f(z)}{z - w} dz.$$

*Proof.* All circles  $C_r$  with center  $w$  and radius  $r$  are homotopic in  $D \setminus \{w\}$ , and the function  $f(z)/(z - w)$  is holomorphic in an open set containing  $D \setminus \{w\}$ . So Cauchy's Theorem 4.6, gives

$$\int_{C_R} \frac{f(z)}{z - w} dz = \int_{C_r} \frac{f(z)}{z - w} dz$$

Now by Exercise 15,

$$\int_{C_r} \frac{1}{z - w} dz = 2\pi i,$$

and we obtain with Proposition 4.4(d)

$$\begin{aligned} \left| \int_{C_R} \frac{f(z)}{z - w} dz - 2\pi i f(w) \right| &= \left| \int_{C_r} \frac{f(z)}{z - w} dz - f(w) \int_{C_r} \frac{1}{z - w} dz \right| = \left| \int_{C_r} \frac{f(z) - f(w)}{z - w} dz \right| \\ &\leq \max_{z \in C_r} \left| \frac{f(z) - f(w)}{z - w} \right| \text{length}(C_r) = \max_{z \in C_r} \frac{|f(z) - f(w)|}{r} 2\pi r \\ &= 2\pi \max_{z \in C_r} |f(z) - f(w)|. \end{aligned}$$

On the right-hand side, we can now take  $r$  as small as we want, and—because  $f$  is continuous at  $w$ —this means we can make  $|f(z) - f(w)|$  as small as we like. Hence the left-hand side has no choice but to be zero, which is what we claimed.  $\square$

This is a useful theorem by itself, but it can be made more generally useful. For example, it will be important to have Cauchy's integral formula when  $w$  is anywhere *inside*  $C_R$ , not just at the *center* of  $C_R$ . In fact, in many cases in which a point  $w$  is inside a simple closed curve  $\gamma$  we can see a homotopy from  $\gamma$  to a small circle around  $w$  so that the homotopy misses  $w$  and remains in the region where  $f$  is holomorphic. In that case the theorem remains true, since, by Cauchy's theorem, the integral of  $f(z)/(z - w)$  around  $\gamma$  is the same as the integral of  $f(z)/(z - w)$  around a small circle centered at  $w$ , and Theorem 4.9 then applies to evaluate the integral. In this discussion we need to be sure that the orientation of the curve  $\gamma$  and the circle match. In general, we say a simple closed curve  $\gamma$  is *positively oriented* if it is parameterized so that the inside is on the *left* of  $\gamma$ . For a circle this corresponds to a counterclockwise orientation.

Here's the general form:

**Theorem 4.10** (Cauchy's Integral Formula). *Suppose  $f$  is holomorphic on the region  $G$ ,  $w \in G$ , and  $\gamma$  is a positively oriented, simple, closed, smooth,  $G$ -contractible curve such that  $w$  is inside  $\gamma$ . Then*

$$f(w) = \frac{1}{2\pi i} \int_{\gamma} \frac{f(z)}{z - w} dz.$$

We have already indicated how to prove this, by combining Cauchy's theorem and the special case, Theorem 4.9. All we need is to find a homotopy in  $G \setminus \{w\}$  between  $\gamma$  and a small circle with center at  $w$ . In all practical cases we can see immediately how to construct such a homotopy, but it is not at all clear how to do so in complete generality; in fact, it is not even clear how to make sense of the "inside" of  $\gamma$  in general. The justification for this is one of the first substantial theorems ever proved in topology. We can state it as follows:

**Theorem 4.11** (Jordan Curve Theorem). *If  $\gamma$  is a positively oriented, simple, closed curve in  $\mathbb{C}$  then  $\mathbb{C} \setminus \gamma$  consists of two connected open sets, the inside and the outside of  $\gamma$ . If a closed disk  $D$  centered at  $w$  lies inside  $\gamma$  then there is a homotopy  $\gamma_s$  from  $\gamma$  to the positively oriented boundary of  $D$ , and, for  $0 < s < 1$ ,  $\gamma_s$  is inside  $\gamma$  and outside of  $D$ .*

*Remarks.* 1. The Jordan Curve Theorem is named after French mathematician Camille Jordan (1838-1922)<sup>4</sup> (the Jordan of Jordan normal form and Jordan matrix, but not Gauss-Jordan elimination).

This theorem, although “intuitively obvious,” is surprisingly difficult to prove. The usual statement of the Jordan curve theorem does not contain the homotopy information; we have borrowed this from a companion theorem to the Jordan curve theorem which is sometimes called the “annulus theorem.” If you want to explore this kind of mathematics you should take a course in topology.

A nice special case of Cauchy’s formula is obtained when  $\gamma$  is a circle centered at  $w$ , parametrized by, say,  $z = w + re^{it}$ ,  $0 \leq t \leq 2\pi$ . Theorem 4.10 gives (if the conditions are met)

$$f(w) = \frac{1}{2\pi i} \int_0^{2\pi} \frac{f(w + re^{it})}{w + re^{it} - w} ire^{it} dt = \frac{1}{2\pi} \int_0^{2\pi} f(w + re^{it}) dt.$$

Even better, we automatically get similar formulas for the real and imaginary part of  $f$ , simply by taking real and imaginary parts on both sides. These identities have the flavor of mean values. Let’s summarize them in the following statement, which is often called a *mean-value theorem*.

**Corollary 4.12.** *Suppose  $f$  is holomorphic on and inside the circle  $z = w + re^{i\theta}$ ,  $0 \leq \theta \leq 2\pi$ . Then*

$$f(w) = \frac{1}{2\pi} \int_0^{2\pi} f(w + re^{i\theta}) d\theta.$$

Furthermore, if  $f = u + iv$ ,

$$u(w) = \frac{1}{2\pi} \int_0^{2\pi} u(w + re^{i\theta}) d\theta \quad \text{and} \quad v(w) = \frac{1}{2\pi} \int_0^{2\pi} v(w + re^{i\theta}) d\theta.$$

This is called a mean value theorem because it is stating that  $f(w)$  is equal to an integral, where the integral is literally the mean of the values of  $f$  along the circle of radius  $r$ :

$$\frac{1}{2\pi} \int_0^{2\pi} f(w + re^{i\theta}) d\theta = \frac{1}{2\pi r} \int_0^{2\pi} f(w + re^{i\theta}) r d\theta = \lim_{\Delta\theta \rightarrow 0} \frac{1}{2\pi r} \sum_{\theta=0}^{2\pi} f(w + re^{i\theta})(r\Delta\theta)$$

where in the final sum the step size is  $\Delta\theta$ .

## Exercises

- Use the definition of length to find the length of the following curves:

(a)  $\gamma(t) = 3t + i$  for  $-1 \leq t \leq 1$

---

<sup>4</sup>For more information on C. Jordan, see [http://en.wikipedia.org/wiki/Camille\\_Jordan](http://en.wikipedia.org/wiki/Camille_Jordan).

- (b)  $\gamma(t) = e^{it}$  for  $0 \leq t \leq \pi$   
 (c)  $\gamma(t) = i \sin(t)$  for  $-\pi \leq t \leq \pi$   
 (d)  $\gamma(t) = (t, t^2)$  for  $0 \leq t \leq 2$
2. Integrate the function  $f(z) = \bar{z}$  over the three curves given in Example 4.2.
3. Evaluate  $\int_{\gamma} \frac{1}{z} dz$  where  $\gamma(t) = \sin t + i \cos t$ ,  $0 \leq t \leq 2\pi$ .
4. Integrate the following functions over the circle  $|z| = 2$ , oriented counterclockwise:
- (a)  $z + \bar{z}$ .  
 (b)  $z^2 - 2z + 3$ .  
 (c)  $1/z^4$ .  
 (d)  $xy$ .
5. Evaluate the integrals  $\int_{\gamma} x dz$ ,  $\int_{\gamma} y dz$ ,  $\int_{\gamma} z dz$  and  $\int_{\gamma} \bar{z} dz$  along each of the following paths. Note that you can get the second two integrals very easily after you calculate the first two, by writing  $z$  and  $\bar{z}$  as  $x \pm iy$ .
- (a)  $\gamma$  is the line segment from 0 to  $1 - i$ .  
 (b)  $\gamma$  is the counterclockwise circle  $|z| = 1$ .  
 (c)  $\gamma$  is the counterclockwise circle  $|z - a| = r$ . Use  $\gamma(t) = a + re^{it}$ .
6. Evaluate  $\int_{\gamma} e^{3z} dz$  for each of the following paths:
- (a) The straight line segment from 1 to  $i$ .  
 (b) The circle  $|z| = 3$ .  
 (c) The parabola  $y = x^2$  from  $x = 0$  to  $x = 1$ .
7. Evaluate  $\int_{\gamma} |z^2| dz$  where  $\gamma$  is the parabola with parametric equation  $\gamma(t) = t + it^2$ ,  $0 \leq t \leq 1$ .
8. Compute  $\int_{\gamma} z$  where  $\gamma$  is the semicircle from 1 through  $i$  to  $-1$ .
9. Compute  $\int_{\gamma} e^z$  where  $\gamma$  is the line segment from 0 to  $z_0$ .
10. Find  $\int_{\gamma} |z|^2$  where  $\gamma$  is the line segment from 2 to  $3 + i$ .
11. Compute  $\int_{\gamma} z + \frac{1}{z}$  where  $\gamma$  is parametrized by  $\gamma(t)$ ,  $0 \leq t \leq 1$ , and satisfies  $\text{Im } \gamma(t) > 0$ ,  $\gamma(0) = -4 + i$ , and  $\gamma(1) = 6 + 2i$ .
12. Find  $\int_{\gamma} \sin z$  where  $\gamma$  is parametrized by  $\gamma(t)$ ,  $0 \leq t \leq 1$ , and satisfies  $\gamma(0) = i$  and  $\gamma(1) = \pi$ .
13. Show that  $\frac{1}{2\pi} \int_0^{2\pi} e^{ik\theta} d\theta$  is 1 if  $k = 0$  and 0 otherwise.
14. Evaluate  $\int_{\gamma} z^{\frac{1}{2}} dz$  where  $\gamma$  is the unit circle and  $z^{\frac{1}{2}}$  is the principal branch. You can use the parameterization  $\gamma(\theta) = e^{i\theta}$  for  $-\pi \leq \theta \leq \pi$ , and remember that the principal branch is defined by  $z^{\frac{1}{2}} = \sqrt{r}e^{i\theta/2}$  if  $z = re^{i\theta}$  for  $-\pi \leq \theta \leq \pi$ .



15. Let  $\gamma$  be the circle with radius  $r$  centered at  $w$ , oriented counterclockwise. You can parameterize this curve as  $z(t) = w + re^{it}$  for  $0 \leq t \leq 2\pi$ . Use the definition of an integral to show that

$$\int_{\gamma} \frac{dz}{z - w} = 2\pi i.$$

16. Suppose a smooth curve is parametrized by both  $\gamma(t)$ ,  $a \leq t \leq b$  and  $\sigma(t)$ ,  $c \leq t \leq d$ , and let  $\tau : [c, d] \rightarrow [a, b]$  be the map which “takes  $\gamma$  to  $\sigma$ ,” that is,  $\sigma = \gamma \circ \tau$ . Show that

$$\int_c^d f(\sigma(t))\sigma'(t) dt = \int_a^b f(\gamma(t))\gamma'(t) dt.$$

(In other words, our definition of the integral  $\int_{\gamma} f$  is independent of the parametrization of  $\gamma$ .)

17. Prove that  $\sim_G$  is an equivalence relation.
18. (a) Prove that any closed curve is  $\mathbb{C}$ -contractible.  
 (b) Prove that any two closed curves are  $\mathbb{C}$ -homotopic.
19. Show that  $\int_{\gamma} z^n dz = 0$  for any closed smooth  $\gamma$  and any integer  $n \neq -1$ . [If  $n$  is negative, assume that  $\gamma$  does not pass through the origin, since otherwise the integral is not defined.]
20. Exercise 19 excluded  $n = -1$  for a very good reason: Exercises 3 and 15 (with  $w = 0$ ) give counterexamples. Generalizing these, if  $m$  is any integer then find a closed curve  $\gamma$  so that  $\int_{\gamma} z^{-1} dz = 2m\pi i$ . (*Hint*: Follow the counterclockwise unit circle through  $m$  complete cycles (for  $m > 0$ ). What should you do if  $m < 0$ ? What if  $m = 0$ ?)
21. Let  $\gamma_r$  be the circle centered at  $2i$  with radius  $r$ , oriented counterclockwise. Compute

$$\int_{\gamma_r} \frac{dz}{z^2 + 1}.$$

(This integral depends on  $r$ .)

22. Suppose  $p$  is a polynomial and  $\gamma$  is a closed smooth path in  $\mathbb{C}$ . Show that

$$\int_{\gamma} p = 0.$$

23. Compute the *real* integral

$$\int_0^{2\pi} \frac{d\theta}{2 + \sin \theta}$$

by writing the sine function in terms of the exponential function and making the substitution  $z = e^{i\theta}$  to turn the real into a complex integral.

24. Show that  $F(z) = \frac{i}{2} \operatorname{Log}(z + i) - \frac{i}{2} \operatorname{Log}(z - i)$  is a primitive of  $\frac{1}{1+z^2}$  for  $\operatorname{Re}(z) > 0$ . Is  $F(z) = \arctan z$ ?

25. Prove the following integration by parts statement. Let  $f$  and  $g$  be holomorphic in  $G$ , and suppose  $\gamma \subset G$  is a smooth curve from  $a$  to  $b$ . Then

$$\int_{\gamma} f g' = f(\gamma(b))g(\gamma(b)) - f(\gamma(a))g(\gamma(a)) - \int_{\gamma} f' g.$$

26. Suppose  $f$  and  $g$  are holomorphic on the region  $G$ ,  $\gamma$  is a closed, smooth,  $G$ -contractible curve, and  $f(z) = g(z)$  for all  $z \in \gamma$ . Prove that  $f(z) = g(z)$  for all  $z$  inside  $\gamma$ .
27. This exercise gives an alternative proof of Cauchy's integral formula (Theorem 4.10), which does not depend on Cauchy's Theorem 4.6. Suppose  $f$  is holomorphic on the region  $G$ ,  $w \in G$ , and  $\gamma$  is a positively oriented, simple, closed, smooth,  $G$ -contractible curve such that  $w$  is inside  $\gamma$ .
- (a) Consider the function  $g : [0, 1] \rightarrow \mathbb{C}$ ,  $g(t) = \int_{\gamma} \frac{f(w+t(z-w))}{z-w} dz$ . Show that  $g' = 0$ . (*Hint:* Use Theorem 1.22 (Leibniz's rule) and then find a primitive for  $\frac{\partial f}{\partial t}(z + t(w - z))$ .)
- (b) Prove Theorem 4.10 by evaluating  $g(0)$  and  $g(1)$ .

28. Prove Corollary 4.7 using Theorem 4.10.

29. Suppose  $a$  is a complex number and  $\gamma_0$  and  $\gamma_1$  are two counterclockwise circles (traversed just once) so that  $a$  is inside both of them. Explain geometrically why  $\gamma_0$  and  $\gamma_1$  are homotopic in  $\mathbb{C} \setminus \{a\}$ .

30. Let  $\gamma_r$  be the counterclockwise circle with center at 0 and radius  $r$ . Find  $\int_{\gamma_r} \frac{dz}{z-a}$ . You should get different answers for  $r < |a|$  and  $r > |a|$ . (*Hint:* In one case  $\gamma_r$  is contractible in  $\mathbb{C} \setminus \{a\}$ . In the other you can combine Exercises 15 and 29.)

31. Let  $\gamma_r$  be the counterclockwise circle with center at 0 and radius  $r$ . Find  $\int_{\gamma_r} \frac{dz}{z^2 - 2z - 8}$  for  $r = 1$ ,  $r = 3$  and  $r = 5$ . (*Hint:* Since  $z^2 - 2z - 8 = (z - 4)(z + 2)$  you can find a partial fraction decomposition of the form  $\frac{1}{z^2 - 2z - 8} = \frac{A}{z - 4} + \frac{B}{z + 2}$ . Now use Exercise 30.)

32. Use the Cauchy integral formula to evaluate the integral in Exercise 31 when  $r = 3$ . (*Hint:* The integrand can be written in each of following ways:

$$\frac{1}{z^2 - 2z - 8} = \frac{1}{(z - 4)(z + 2)} = \frac{1/(z - 4)}{z + 2} = \frac{1/(z + 2)}{z - 4}.$$

Which of these forms corresponds to the Cauchy integral formula for the curve  $\gamma_3$ ?

33. Find  $\int_{|z+1|=2} \frac{z^2}{4-z^2}$ .
34. What is  $\int_{|z|=1} \frac{\sin z}{z}$ ?
35. Evaluate  $\int_{|z|=2} \frac{e^z}{z(z-3)}$  and  $\int_{|z|=4} \frac{e^z}{z(z-3)}$ .

## Chapter 5

# Consequences of Cauchy's Theorem

*If things are nice there is probably a good reason why they are nice: and if you do not know at least one reason for this good fortune, then you still have work to do.*

Richard Askey

### 5.1 Extensions of Cauchy's Formula

We now derive formulas for  $f'$  and  $f''$  which resemble Cauchy's formula (Theorem 4.10).

**Theorem 5.1.** *Suppose  $f$  is holomorphic on the region  $G$ ,  $w \in G$ , and  $\gamma$  is a positively oriented, simple, closed, smooth,  $G$ -contractible curve such that  $w$  is inside  $\gamma$ . Then*

$$f'(w) = \frac{1}{2\pi i} \int_{\gamma} \frac{f(z)}{(z-w)^2} dz$$

and

$$f''(w) = \frac{1}{\pi i} \int_{\gamma} \frac{f(z)}{(z-w)^3} dz.$$

This innocent-looking theorem has a very powerful consequence: just from knowing that  $f$  is holomorphic we know of the existence of  $f''$ , that is,  $f'$  is also holomorphic in  $G$ . Repeating this argument for  $f'$ , then for  $f''$ ,  $f'''$ , etc., gives the following statement, which has no analog whatsoever in the reals.

**Corollary 5.2.** *If  $f$  is differentiable in the region  $G$  then  $f$  is infinitely differentiable in  $G$ .*

*Proof of Theorem 5.1.* The idea of the proof is very similar to the proof of Cauchy's integral formula (Theorem 4.10). We will study the following difference quotient, which we can rewrite as follows by Theorem 4.10.

$$\begin{aligned} \frac{f(w + \Delta w) - f(w)}{\Delta w} &= \frac{1}{\Delta w} \left( \frac{1}{2\pi i} \int_{\gamma} \frac{f(z)}{z - (w + \Delta w)} dz - \frac{1}{2\pi i} \int_{\gamma} \frac{f(z)}{z - w} dz \right) \\ &= \frac{1}{2\pi i} \int_{\gamma} \frac{f(z)}{(z - w - \Delta w)(z - w)} dz. \end{aligned}$$

Hence we will have to show that the following expression gets arbitrarily small as  $\Delta w \rightarrow 0$ :

$$\begin{aligned} \frac{f(w + \Delta w) - f(w)}{\Delta w} - \frac{1}{2\pi i} \int_{\gamma} \frac{f(z)}{(z - w)^2} dz &= \frac{1}{2\pi i} \int_{\gamma} \frac{f(z)}{(z - w - \Delta w)(z - w)} - \frac{f(z)}{(z - w)^2} dz \\ &= \Delta w \frac{1}{2\pi i} \int_{\gamma} \frac{f(z)}{(z - w - \Delta w)(z - w)^2} dz. \end{aligned}$$

This can be made arbitrarily small if we can show that the integral stays bounded as  $\Delta w \rightarrow 0$ . In fact, by Proposition 4.4(d), it suffices to show that the *integrand* stays bounded as  $\Delta w \rightarrow 0$  (because  $\gamma$  and hence  $\text{length}(\gamma)$  are fixed). Let  $M = \max_{z \in \gamma} |f(z)|$  and  $N = \max_{z \in \gamma} |z - w|$ . Since  $\gamma$  is a closed set, there is some positive  $\delta$  so that the open disk of radius  $\delta$  around  $w$  does not intersect  $\gamma$ ; that is,  $|z - w| \geq \delta$  for all  $z$  on  $\gamma$ . By the reverse triangle inequality we have for all  $z \in \gamma$

$$\left| \frac{f(z)}{(z - w - \Delta w)(z - w)^2} \right| \leq \frac{|f(z)|}{(|z - w| - |\Delta w|)|z - w|^2} \leq \frac{M}{(\delta - |\Delta w|)N^2},$$

which certainly stays bounded as  $\Delta w \rightarrow 0$ . The proof of the formula for  $f''$  is very similar and will be left for the exercises (see Exercise 2).  $\square$

*Remarks.* 1. Theorem 5.1 suggests that there are similar formulas for the higher derivatives of  $f$ . This is in fact true, and theoretically one could obtain them one by one with the methods of the proof of Theorem 5.1. However, once we start studying power series for holomorphic functions, we will obtain such a result much more easily; so we save the derivation of formulas for higher derivatives of  $f$  for later (see Corollary 8.6).

2. Theorem 5.1 can also be used to compute certain integrals. We give some examples of this application next.

**Example 5.3.**

$$\int_{|z|=1} \frac{\sin(z)}{z^2} dz = 2\pi i \left. \frac{d}{dz} \sin(z) \right|_{z=0} = 2\pi i \cos(0) = 2\pi i.$$

**Example 5.4.** To compute the integral

$$\int_{|z|=2} \frac{dz}{z^2(z - 1)},$$

we first split up the integration path as illustrated in Figure 5.1: Introduce an additional path which separates 0 and 1. If we integrate on these two new closed paths ( $\gamma_1$  and  $\gamma_2$ ) counterclockwise, the two contributions along the new path will cancel each other. The effect is that we transformed an integral, for which two singularities were inside the integration path, into a sum of two integrals, each of which has only one singularity inside the integration path; these new integrals we know

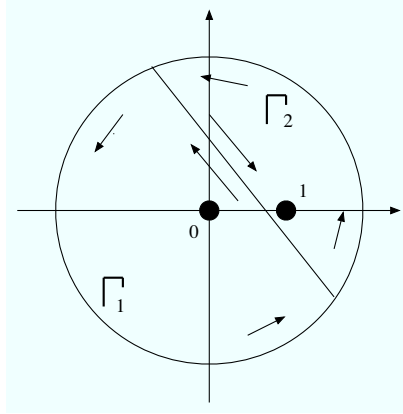

Figure 5.1: Example 5.4

how to deal with.

$$\begin{aligned}
 \int_{|z|=2} \frac{dz}{z^2(z-1)} &= \int_{\gamma_1} \frac{dz}{z^2(z-1)} + \int_{\gamma_2} \frac{dz}{z^2(z-1)} \\
 &= \int_{\gamma_1} \frac{\frac{1}{z-1}}{z^2} dz + \int_{\gamma_2} \frac{\frac{1}{z^2}}{z-1} dz \\
 &= 2\pi i \left. \frac{d}{dz} \frac{1}{z-1} \right|_{z=0} + 2\pi i \frac{1}{1^2} \\
 &= 2\pi i \left( -\frac{1}{(-1)^2} \right) + 2\pi i \\
 &= 0.
 \end{aligned}$$

**Example 5.5.**

$$\int_{|z|=1} \frac{\cos(z)}{z^3} dz = \pi i \left. \frac{d^2}{dz^2} \cos(z) \right|_{z=0} = \pi i (-\cos(0)) = -\pi i.$$

## 5.2 Taking Cauchy's Formula to the Limit

Many beautiful applications of Cauchy's formula arise from considerations of the limiting behavior of the formula as the curve gets arbitrarily large. We shall look at a few applications along these lines in this section, but this will be a recurring theme throughout the rest of the book.

The first application is understanding the roots of polynomials. As a preparation we prove the following inequality, which is generally quite useful. It simply says that for large enough  $z$ , a polynomial of degree  $d$  looks almost like a constant times  $z^d$ .

**Lemma 5.6.** *Suppose  $p(z)$  is a polynomial of degree  $d$  with leading coefficient  $a_d$ . Then there is real number  $R_0$  so that*

$$\frac{1}{2} |a_d| |z|^d \leq |p(z)| \leq 2 |a_d| |z|^d$$

for all  $z$  satisfying  $|z| \geq R_0$ .

*Proof.* Since  $p(z)$  has degree  $d$  its leading coefficient  $a_d$  is not zero, and we can factor out  $a_d z^d$ :

$$\begin{aligned} |p(z)| &= \left| a_d z^d + a_{d-1} z^{d-1} + a_{d-2} z^{d-2} + \cdots + a_1 z + a_0 \right| \\ &= |a_d| |z|^d \left| 1 + \frac{a_{d-1}}{a_d z} + \frac{a_{d-2}}{a_d z^2} + \cdots + \frac{a_1}{a_d z^{d-1}} + \frac{a_0}{a_d z^d} \right|. \end{aligned}$$

Then the sum inside the last factor has limit 1 as  $z \rightarrow \infty$  so its modulus is between  $\frac{1}{2}$  and 2 for all large enough  $z$ .  $\square$

**Theorem 5.7** (Fundamental Theorem of Algebra<sup>1</sup>). *Every non-constant polynomial has a root in  $\mathbb{C}$ .*

*Proof.*<sup>2</sup> Suppose (by way of contradiction) that  $p$  does not have any roots, that is,  $p(z) \neq 0$  for all  $z \in \mathbb{C}$ . Then Cauchy's formula gives us

$$\frac{1}{p(0)} = \frac{1}{2\pi i} \int_{C_R} \frac{1/p(z)}{z} dz$$

where  $C_R$  is the circle of radius  $R$  around the origin. Notice that the value of the integral does not depend on  $R$ , so we have

$$\frac{1}{p(0)} = \lim_{R \rightarrow \infty} \frac{1}{2\pi i} \int_{C_R} \frac{dz}{z p(z)}. \quad (*)$$

But now we can see that the limit of the integral is 0: By Lemma 5.6 we have  $|z p(z)| \geq \frac{1}{2} |a_d| |z|^{d+1}$  for all large  $z$ , where  $d$  is the degree of  $p(z)$  and  $a_d$  is the leading coefficient of  $p(z)$ . Hence, using Proposition 4.4(d) and the formula for the circumference of a circle we see that the integral can be bounded as

$$\left| \frac{1}{2\pi i} \int_{C_R} \frac{dz}{z p(z)} \right| \leq \frac{1}{2\pi} \cdot \frac{2}{|a_d| R^{d+1}} \cdot (2\pi R) = \frac{2}{|a_d| R^d}$$

and this has limit 0 as  $R \rightarrow \infty$ . But, plugging into (\*), we have shown that  $\frac{1}{p(0)} = 0$ , which is impossible.  $\square$

*Remarks.* 1. This statement implies that any polynomial  $p$  can be factored into linear terms of the form  $z - a$  where  $a$  is a root of  $p$ , as we can apply the corollary, after getting a root  $a$ , to  $\frac{p(z)}{z-a}$  (which is again a polynomial by the division algorithm), etc. (see also Exercise 10).

2. A compact reformulation of the Fundamental Theorem of Algebra is to say that  $\mathbb{C}$  is *algebraically closed*. Thus,  $\mathbb{R}$  is not algebraically closed.

---

<sup>1</sup>The Fundamental Theorem of Algebra was first proved by Gauß (in his doctoral dissertation in 1799, which had a flaw, and later three additional rigorous proofs), although its statement had been assumed to be correct long before Gauß's time.

<sup>2</sup>It is amusing that such an important algebraic result can be proved 'purely analytically.' There are proofs of the Fundamental Theorem of Algebra which do not use complex analysis. On the other hand, all proofs use *some* analysis (such as the intermediate-value theorem). The Fundamental Theorem of Algebra refers to Algebra in the sense that it existed in 1799, not to modern algebra. Thus, it has been remarked that the Fundamental Theorem of Algebra is neither fundamental to algebra nor even a theorem of algebra.

**Example 5.8.** The polynomial  $p(x) = 2x^4 + 5x^2 + 3$  is such that all of its coefficients are real. However,  $p$  has *no* roots in  $\mathbb{R}$ . The Fundamental Theorem of Algebra states that  $p$  must have one (in fact, 4) roots in  $\mathbb{C}$ :

$$p(x) = (x^2 + 1)(2x^2 + 3) = (x + i)(x - i)(\sqrt{2}x + \sqrt{3}i)(\sqrt{2}x - \sqrt{3}i).$$

A powerful consequence of (the first half of) Theorem 5.1 is the following.

**Corollary 5.9** (Liouville's<sup>3</sup> Theorem<sup>4</sup>). *Every bounded entire function is constant.*

*Proof.* Suppose  $|f(z)| \leq M$  for all  $z \in \mathbb{C}$ . Given any  $w \in \mathbb{C}$ , we apply Theorem 5.1 with the circle  $C_R$  of radius  $R$  centered at  $w$ . Note that we can choose any  $R$  because  $f$  is entire. Now we apply Proposition 4.4 (d), remembering that  $C_R$  has circumference  $2\pi R$  and  $|z - w| = R$  for all  $z$  on  $C_R$ :

$$\begin{aligned} |f'(w)| &= \left| \frac{1}{2\pi i} \int_{C_R} \frac{f(z)}{(z-w)^2} dz \right| \leq \frac{1}{2\pi} \max_{z \in \gamma_R} \left| \frac{f(z)}{(z-w)^2} \right| \cdot 2\pi R = \frac{1}{2\pi} \max_{z \in \gamma_R} \frac{|f(z)|}{R^2} 2\pi R = \max_{z \in \gamma} \frac{|f(z)|}{R} \\ &\leq \frac{M}{R}. \end{aligned}$$

The right-hand side can be made arbitrarily small, as we are allowed to make  $R$  as large as we want. This implies that  $f' = 0$ , and hence, by Theorem 2.14,  $f$  is constant.  $\square$

As an example of the usefulness of Liouville's theorem we give another proof of the fundamental theorem of algebra, which is close to Gauß's original proof:

*Another proof of the fundamental theorem of algebra.* Suppose (by way of contradiction) that  $p$  does not have any roots, that is,  $p(z) \neq 0$  for all  $z \in \mathbb{C}$ . Then, because  $p$  is entire, the function  $f(z) = \frac{1}{p(z)}$  is entire. But  $f \rightarrow 0$  as  $|z|$  becomes large as a consequence of Lemma 5.6; that is,  $f$  is also bounded (Exercise 9). Now apply Corollary 5.9 to deduce that  $f$  is constant. Hence  $p$  is constant, which contradicts our assumptions.  $\square$

As one more example of this theme of getting results from Cauchy's formula by taking the limit as a path goes to infinity, we compute an improper integral.

**Example 5.10.** Let  $\sigma$  be the counterclockwise semicircle formed by the segment  $S$  of the real axis from  $-R$  to  $R$ , followed by the circular arc  $T$  of radius  $R$  in the upper half plane from  $R$  to  $-R$ , where  $R > 1$ . We shall integrate the function

$$f(z) = \frac{1}{z^2 + 1} = \frac{1/(z+i)}{z-i} = \frac{g(z)}{z-i}, \text{ where } g(z) = \frac{1}{z+i}$$

Since  $g(z)$  is holomorphic inside and on  $\sigma$  and  $i$  is inside  $\sigma$ , we can apply Cauchy's formula:

$$\frac{1}{2\pi i} \int_{\sigma} \frac{dz}{z^2 + 1} = \frac{1}{2\pi i} \int_{\sigma} \frac{g(z)}{z-i} dz = g(i) = \frac{1}{i+i} = \frac{1}{2i},$$

<sup>3</sup>For more information about Joseph Liouville (1809–1882), see <http://www-groups.dcs.st-and.ac.uk/~history/Biographies/Liouville.html>.

<sup>4</sup>This theorem is for historical reasons erroneously attributed to Liouville. It was published earlier by Cauchy; in fact, Gauß may well have known about it before Cauchy.

and so

$$\int_S \frac{dz}{z^2 + 1} + \int_T \frac{dz}{z^2 + 1} = \int_\sigma \frac{dz}{z^2 + 1} = 2\pi i \cdot \frac{1}{2i} = \pi. \quad (**)$$

Now this formula holds for all  $R > 1$ , so we can take the limit as  $R \rightarrow \infty$ . First,  $|z^2 + 1| \geq \frac{1}{2}|z|^2$  for large enough  $z$  by Lemma 5.6, so we can bound the integral over  $T$  using Proposition 4.4(d):

$$\left| \int_T \frac{dz}{z^2 + 1} \right| \leq \frac{2}{R^2} \cdot \pi R = \frac{2}{R}$$

and this has limit 0 as  $R \rightarrow \infty$ . On the other hand, we can parameterize the integral over  $S$  using  $z = t$ ,  $-R \leq t \leq R$ , obtaining

$$\int_S \frac{dz}{z^2 + 1} = \int_{-R}^R \frac{dt}{1 + t^2}.$$

As  $R \rightarrow \infty$  this approaches an improper integral. Making these observations in the limit of the formula (\*\*) as  $R \rightarrow \infty$  now produces

$$\int_{-\infty}^{\infty} \frac{dt}{t^2 + 1} = \pi.$$

Of course this integral can be evaluated almost as easily using standard formulas from calculus. However, just a slight modification of this example leads to an improper integral which is far beyond the scope of basic calculus; see Exercise 13.

### 5.3 Antiderivatives

We begin this section with a familiar definition from real calculus:

**Definition 5.11.** Let  $G$  be a region of  $\mathbb{C}$ . For any functions  $f, F : G \rightarrow \mathbb{C}$ , if  $F$  is holomorphic on  $G$  and  $F'(z) = f(z)$  for all  $z \in G$ , then  $F$  is an *antiderivative of  $f$  on  $G$* , also known as a *primitive of  $f$  on  $G$* .

In short, an antiderivative of  $f$  is a function with  $F' = f$ .

**Example 5.12.** We have already seen that  $F(z) = z^2$  is entire, and has derivative  $f(z) = 2z$ . Thus,  $F$  is an antiderivative of  $f$  on any region  $G$ .

Just like in the real case, there are complex versions of the Fundamental Theorems of Calculus. The Fundamental Theorems of Calculus makes a number of important claims: that continuous functions are integrable, their antiderivatives are continuous and differentiable, and that antiderivatives provide easy ways to compute values of definite integrals. The difference between the real case and the complex case is that for the complex case, we need to think about integrals over arbitrary curves in 2-dimensional regions.

To state the first Fundamental Theorem, we need some topological definitions:

**Definition 5.13.** A region  $G \subset \mathbb{C}$  is *simply connected* if every simple closed curve in  $G$  is  $G$ -contractible. That is, for any simple closed curve  $\gamma \subset G$ , the interior of  $\gamma$  in  $\mathbb{C}$  is also completely contained in  $G$ .



Loosely, simply connected means  $G$  has no 'holes'.

**Theorem 5.14.** [*The First Fundamental Theorem of Calculus*] Suppose  $G \subseteq \mathbb{C}$  is a simply-connected region, and fix some basepoint  $z_0 \in G$ . For each point  $z \in G$ , let  $\gamma_z$  denote a smooth curve in  $G$  from  $z_0$  to  $z$ . Let  $f : G \rightarrow \mathbb{C}$  be a holomorphic function. Then the function  $F(z) : G \rightarrow \mathbb{C}$  defined by

$$F(z) := \int_{\gamma_z} f$$

is holomorphic on  $G$  with  $F'(z) = f(z)$ .

In short, every holomorphic function on a simply-connected region has a primitive.

*Proof.* We leave this to the exercises, Exercise 14. □

**Theorem 5.15.** [*The Second Fundamental Theorem of Calculus*] Suppose  $G \subseteq \mathbb{C}$  is a simply connected region. Let  $\gamma \subset G$  be a smooth curve with parametrization  $\gamma(t)$ ,  $a \leq t \leq b$ . If  $f : G \rightarrow \mathbb{C}$  is holomorphic on  $G$  and  $F$  is any primitive of  $f$  on  $G$ , then

$$\int_{\gamma} f = F(\gamma(b)) - F(\gamma(a)).$$

*Remarks.* 1. Actually, more is true. The assumptions that  $G$  is simply connected and  $f$  is holomorphic are both unnecessary.

*Proof.* The antiderivative  $F$  prescribed by the First Fundamental Theorem of Calculus satisfies the desired equation by definition. For any other antiderivative  $\tilde{F}$  of  $f$ , we have that  $F'(z) = \tilde{F}'(z)$  for  $z \in \tilde{F}$ , so the function  $H(z) := F(z) - \tilde{F}(z)$  is holomorphic with derivative 0, so is constant. Thus,  $\tilde{F}(z) = F(z) + c$  for some constant  $c \in \mathbb{C}$ . Then

$$\tilde{F}(\gamma(b)) - \tilde{F}(\gamma(a)) = F(\gamma(b)) - F(\gamma(a)) = \int_{\gamma} f,$$

as desired. □

There are many interesting consequences of the Fundamental Theorems. One consequence comes from the *proof* of Theorem 5.14: we will not really need the fact that every closed curve in  $G$  is contractible, just that every closed curve gives a zero integral for  $f$ . This fact can be exploited to give a sort of converse statement to Corollary 4.7.

**Corollary 5.16** (Morera's<sup>5</sup> Theorem). *Suppose  $f$  is continuous in the region  $G$  and*

$$\int_{\gamma} f = 0$$

*for all smooth closed paths  $\gamma \subset G$ . Then  $f$  is holomorphic in  $G$ .*

---

<sup>5</sup>For more information about Giancinto Morera (1856–1907), see <http://www-groups.dcs.st-and.ac.uk/~history/Biographies/Morera.html>.

*Proof.* As in the proof of Theorem 5.14, we fix an  $z_0 \in G$  and define

$$F(z) = \int_{\gamma_z} f,$$

where  $\gamma_z$  is any smooth curve in  $G$  from  $z_0$  to  $z$ . As above, this is a well-defined function because all closed paths give a zero integral for  $f$ ; and exactly as in Exercise 14 we can show that  $F$  is a primitive for  $f$  in  $G$ . Because  $F$  is holomorphic on  $G$ , Corollary 5.2 gives that  $f$  is also holomorphic on  $G$ .  $\square$

We now mention two interesting corollaries of the Second Fundamental Theorem.

**Corollary 5.17.** *If  $f$  is holomorphic on  $G$ , then an antiderivative of  $f$  exists on  $G$ , and  $\int_{\gamma} f$  is independent of the path  $\gamma \subset G$  between  $\gamma(a)$  and  $\gamma(b)$ .*

If  $f$  is holomorphic on  $G$ , we say  $\int_{\gamma} f$  is *path-independent*.

Example 4.2 shows that a path-independent integral is quite special; it also says that the function  $\bar{z}^2$  does not have an antiderivative in, for example, the region  $\{z \in \mathbb{C} : |z| < 2\}$ . (Actually, the function  $\bar{z}^2$  does not have an antiderivative in any nonempty region—prove it!)

In the special case that  $\gamma$  is closed (that is,  $\gamma(a) = \gamma(b)$ ), we immediately get the following nice consequence (which also follows from Cauchy's Integral Formula).

**Corollary 5.18.** *Suppose  $G \subseteq \mathbb{C}$  is open,  $\gamma$  is a smooth closed curve in  $G$ , and  $f$  is holomorphic on  $G$  and has an antiderivative on  $G$ . Then*

$$\int_{\gamma} f = 0.$$

## Exercises

1. Compute the following integrals, where  $C$  is the boundary of the square with corners at  $\pm 4 \pm 4i$ :

(a)  $\int_C \frac{e^z}{z^3} dz.$

(b)  $\int_C \frac{e^z}{(z - \pi i)^2} dz.$

(c)  $\int_C \frac{\sin(2z)}{(z - \pi)^2} dz.$

(d)  $\int_C \frac{e^z \cos(z)}{(z - \pi)^3} dz.$

2. Prove the formula for  $f''$  in Theorem 5.1.
3. Integrate the following functions over the circle  $|z| = 3$ , oriented counterclockwise:

(a)  $\text{Log}(z - 4i).$

(b)  $\frac{1}{z - \frac{1}{2}}.$

- (c)  $\frac{1}{z^2-4}$ .  
 (d)  $\frac{\exp z}{z^3}$ .  
 (e)  $\left(\frac{\cos z}{z}\right)^2$ .  
 (f)  $iz^{-3}$ .  
 (g)  $\frac{\sin z}{(z^2+\frac{1}{2})^2}$ .  
 (h)  $\frac{\exp z}{(z-w)^2}$ , where  $w$  is any fixed complex number with  $|w| \neq 3$ .  
 (i)  $\frac{1}{(z+4)(z^2+1)}$ .

4. Evaluate  $\int_{|z|=3} \frac{e^{2z} dz}{(z-1)^2(z-2)}$ .

5. Prove that  $\int_{\gamma} z \exp(z^2) dz = 0$  for any closed curve  $\gamma$ .

6. Show that  $\exp(\sin z)$  has an antiderivative on  $\mathbb{C}$ .

7. Find a (maximal size) set on which  $f(z) = \exp\left(\frac{1}{z}\right)$  has an antiderivative. (How does this compare with the real function  $f(x) = e^{1/x}$ ?)

8. Compute the following integrals; use the principal value of  $z^i$ . (*Hint*: one of these integrals is considerably easier than the other.)

(a)  $\int_{\gamma_1} z^i dz$  where  $\gamma_1(t) = e^{it}$ ,  $-\frac{\pi}{2} \leq t \leq \frac{\pi}{2}$ .

(b)  $\int_{\gamma_2} z^i dz$  where  $\gamma_2(t) = e^{it}$ ,  $\frac{\pi}{2} \leq t \leq \frac{3\pi}{2}$ .

9. Suppose  $f$  is continuous on  $\mathbb{C}$  and  $\lim_{z \rightarrow \infty} f(z) = 0$ . Show that  $f$  is bounded. (*Hint*: From the definition of limit at infinity (with  $\epsilon = 1$ ) there is  $R > 0$  so that  $|f(z) - 0| = |f|(z) < 1$  if  $|z| > R$ . Is  $f$  bounded for  $|z| \leq R$ ?)

10. Let  $p$  be a polynomial of degree  $n > 0$ . Prove that there exist complex numbers  $c, z_1, z_2, \dots, z_k$  and positive integers  $j_1, \dots, j_k$  such that

$$p(z) = c(z - z_1)^{j_1} (z - z_2)^{j_2} \cdots (z - z_k)^{j_k},$$

where  $j_1 + \cdots + j_k = n$ .

11. Show that a polynomial of odd degree with real coefficients must have a real zero. (*Hint*: Exercise 21b in Chapter 1.)

12. Suppose  $f$  is entire and there exist constants  $a, b$  such that  $|f(z)| \leq a|z| + b$  for all  $z \in \mathbb{C}$ . Prove that  $f$  is a linear polynomial (that is, of degree  $\leq 1$ ).

13. In this problem  $F(z) = \frac{e^{iz}}{z^2+1}$  and  $R > 1$ . Modify the example at the end of Section 5.2:

- (a) Show that  $\int_{\sigma} F(z) dz = \frac{\pi}{e}$  if  $\sigma$  is the counterclockwise semicircle formed by the segment  $S$  of the real axis from  $-R$  to  $R$ , followed by the circular arc  $T$  of radius  $R$  in the upper half plane from  $R$  to  $-R$ .

- (b) Show that  $|e^{iz}| \leq 1$  for  $z$  in the upper half plane, and conclude that  $|F(z)| \leq \frac{2}{|z|^2}$  for  $z$  large enough.
- (c) Show that  $\lim_{R \rightarrow \infty} \int_T F(z) dz = 0$ , and hence  $\lim_{R \rightarrow \infty} \int_S F(z) dz = \frac{\pi}{e}$ .
- (d) Conclude, by parameterizing the integral over  $S$  in terms of  $t$  and just considering the real part, that  $\int_{-\infty}^{\infty} \frac{\cos(t)}{t^2+1} dt = \frac{\pi}{e}$ .

14. Prove Theorem 5.14, as follows.

- (a) Use Cauchy's Theorem to show that, for a given  $z \in G$ , the value of  $F(z)$  is independent of the choice of  $\gamma_z$ .
- (b) Fix  $z, z' \in G$  such that the straight line  $\gamma$  connecting  $z$  to  $z'$  is contained in  $G$ . Again using Cauchy's Theorem, show that

$$F(z') - F(z) = \int_{\gamma} f.$$

- (c) Use the fact that  $f$  is continuous to show that for any fixed  $z \in \mathbb{C}$  and any  $\epsilon > 0$ , there is a  $\Delta z \in \mathbb{C}$  such that

$$\left| \frac{F(z) - F(z + \Delta z)}{\Delta z} - f(z) \right| < \epsilon.$$

- (d) Conclude that  $F'(z) = f(z)$ .

15. Prove Corollary 5.17.

16. Prove Corollary 5.18.

# Chapter 6

## Harmonic Functions

*The shortest route between two truths in the real domain passes through the complex domain.*  
J. Hadamard

### 6.1 Definition and Basic Properties

We will now spend a chapter on certain functions defined on subsets of the complex plane which are *real* valued. The main motivation for studying them is that the partial differential equation they satisfy is very common in the physical sciences.

Recall from Section 2.4 the definition of a harmonic function:

**Definition 6.1.** Let  $G \subseteq \mathbb{C}$  be a region. A function  $u : G \rightarrow \mathbb{R}$  is *harmonic* in  $G$  if it has continuous second partials in  $G$  and satisfies the *Laplace*<sup>1</sup> equation

$$u_{xx} + u_{yy} = 0$$

in  $G$ .

There are (at least) two reasons why harmonic functions are part of the study of complex analysis, and they can be found in the next two theorems.

**Proposition 6.2.** *Suppose  $f = u + iv$  is holomorphic in the region  $G$ . Then  $u$  and  $v$  are harmonic in  $G$ .*

*Proof.* First, by Corollary 5.2,  $f$  is infinitely differentiable, and hence so are  $u$  and  $v$ . In particular,  $u$  and  $v$  have continuous second partials. By Theorem 2.15,  $u$  and  $v$  satisfy the Cauchy–Riemann equations

$$u_x = v_y \quad \text{and} \quad u_y = -v_x$$

in  $G$ . Hence

$$u_{xx} + u_{yy} = (u_x)_x + (u_y)_y = (v_y)_x + (-v_x)_y = v_{yx} - v_{xy} = 0$$

in  $G$ . Note that in the last step we used the fact that  $v$  has continuous second partials. The proof that  $v$  satisfies the Laplace equation is completely analogous.  $\square$

---

<sup>1</sup>For more information about Pierre-Simon Laplace (1749–1827), see <http://www-groups.dcs.st-and.ac.uk/~history/Biographies/Laplace.html>.

Proposition 6.2 shouts for a converse theorem. There are, however, functions which are harmonic in a region  $G$  but not the real part (say) of an holomorphic function in  $G$  (Exercise 3). We do obtain a converse of Proposition 6.2 if we restrict ourselves to *simply connected* regions.

**Theorem 6.3.** *Suppose  $u$  is harmonic on the simply connected region  $G$ . Then there exists a harmonic function  $v$  such that  $f = u + iv$  is holomorphic in  $G$ .*

*Remark.* The function  $v$  is called a *harmonic conjugate* of  $u$ .

*Proof.* We will explicitly construct the holomorphic function  $f$  (and thus  $v = \text{Im } f$ ). First, let

$$g = u_x - iu_y.$$

The plan is to prove that  $g$  is holomorphic, and then to construct an antiderivative of  $g$ , which will be almost the function  $f$  that we're after. To prove that  $g$  is holomorphic, we use Theorem 2.15: first because  $u$  is harmonic,  $\text{Re } g = u_x$  and  $\text{Im } g = -u_y$  have continuous partials. Moreover, again because  $u$  is harmonic, they satisfy the Cauchy–Riemann equations:

$$(\text{Re } g)_x = u_{xx} = -u_{yy} = (\text{Im } g)_y$$

and

$$(\text{Re } g)_y = u_{xy} = u_{yx} = -(\text{Im } g)_x.$$

Now that we know that  $g$  is holomorphic in  $G$ , we can use Theorem 5.14 to obtain a primitive  $h$  of  $g$  on  $G$ . (Note that for the application of this theorem we need the fact that  $G$  is simply connected.) Suppose we decompose  $h$  into its real and imaginary parts as  $h = a + ib$ . Then, again using Theorem 2.15,

$$g = h' = a_x + ib_x = a_x - ia_y.$$

(The second equation follows with the Cauchy–Riemann equations.) But the real part of  $g$  is  $u_x$ , so that we obtain  $u_x = a_x$  or  $u(x, y) = a(x, y) + c(y)$  for some function  $c$  which only depends on  $y$ . On the other hand, comparing the imaginary parts of  $g$  and  $h'$  yields  $-u_y = -a_y$  or  $u(x, y) = a(x, y) + c(x)$ , and  $c$  depends only on  $x$ . Hence  $c$  has to be constant, and  $u = a + c$ . But then

$$f = h - c$$

is a function holomorphic in  $G$  whose real part is  $u$ , as promised.  $\square$

*Remark.* In hindsight, it should not be surprising that the function  $g$  which we first constructed is the derivative of the sought-after function  $f$ . Namely, by Theorem 2.15 such a function  $f = u + iv$  must satisfy

$$f' = u_x + iv_x = u_x - iu_y.$$

(The second equation follows with the Cauchy–Riemann equations.) It is also worth mentioning that the proof shows that if  $u$  is harmonic in  $G$  then  $u_x$  is the real part of a function holomorphic in  $G$  *regardless whether  $G$  is simply connected or not*.

As one might imagine, the two theorems we've just proved allow for a powerful interplay between harmonic and holomorphic functions. In that spirit, the following theorem might appear not too surprising. It is, however, a very strong result, which one might appreciate better when looking back at the simple definition of harmonic functions.

**Corollary 6.4.** *A harmonic function is infinitely differentiable.*

*Proof.* Suppose  $u$  is harmonic in  $G$ . Fix  $z_0 \in G$  and  $r > 0$  such that the disk

$$D = \{z \in \mathbb{C} : |z - z_0| < r\}$$

is contained in  $G$ .  $D$  is simply connected, so by the last theorem, there exists a function  $f$  holomorphic in  $D$  such that  $u = \operatorname{Re} f$  on  $D$ . By Corollary 5.2,  $f$  is infinitely differentiable on  $D$ , and hence so is its real part  $u$ . Because  $z_0 \in D$ , we showed that  $u$  is infinitely differentiable at  $z_0$ , and because  $z_0$  was chosen arbitrarily, we proved the statement.  $\square$

*Remark.* This is the first in a series of proofs which uses the fact that the property of being harmonic is a *local* property—it is a property at each point of a certain region. Note that we did not construct a function  $f$  which is holomorphic in  $G$  but we only constructed such a function on the disk  $D$ . This  $f$  might very well differ from one disk to the next.

## 6.2 Mean-Value and Maximum/Minimum Principle

The following identity is the harmonic analog of Cauchy's integral formula, Theorem 4.10.

**Theorem 6.5.** *Suppose  $u$  is harmonic in the region  $G$ , and  $\{z \in \mathbb{C} : |z - w| \leq r\} \subset G$ . Then*

$$u(w) = \frac{1}{2\pi} \int_0^{2\pi} u(w + re^{it}) dt.$$

*Proof.* The disk  $D = \{z \in \mathbb{C} : |z - w| \leq r\}$  is simply connected, so by Theorem 6.3 there is a function  $f$  holomorphic on  $D$  such that  $u = \operatorname{Re} f$  on  $D$ . Now we apply Corollary 4.12 to  $f$ :

$$f(w) = \frac{1}{2\pi} \int_0^{2\pi} f(w + re^{it}) dt.$$

The statement follows by taking the real part on both sides.  $\square$

Theorem 6.5 states that harmonic functions have the *mean-value property*. The following result is a fairly straightforward consequence of this property. The function  $u : G \subset \mathbb{C} \rightarrow \mathbb{R}$  has a *strong relative maximum* at  $w$  if there exists a disk  $D = \{z \in \mathbb{C} : |z - w| < R\} \subset G$  such that  $u(z) \leq u(w)$  for all  $z \in D$  and  $u(z_0) < u(w)$  for some  $z_0 \in D$ . The definition of a *strong relative minimum* is completely analogous.

**Theorem 6.6.** *If  $u$  is harmonic in the region  $G$ , then it does not have a strong relative maximum or minimum in  $G$ .*

*Proof.* Assume (by way of contradiction) that  $w$  is a strong local maximum of  $u$  in  $G$ . Then there is a disk in  $G$  centered at  $w$  containing a point  $z_0$  with  $u(z_0) < u(w)$ . Suppose  $|z_0 - w| = r$ ; we apply Theorem 6.5 with this  $r$ :

$$u(w) = \frac{1}{2\pi} \int_0^{2\pi} u(w + re^{it}) dt.$$

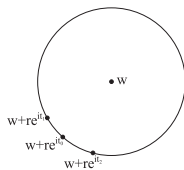

Figure 6.1: Proof of Theorem 6.6.

Intuitively, this cannot hold, because some of the function values we're integrating are smaller than  $u(w)$ , contradicting the mean-value property. To make this into a thorough argument, suppose that  $z_0 = w + re^{it_0}$  for  $0 \leq t_0 < 2\pi$ . Because  $u(z_0) < u(w)$  and  $u$  is continuous, there is a whole interval of parameters, say  $t_0 \leq t < t_1$ , such that  $u(w + re^{it}) < u(w)$ .

Now we split up the mean-value integral:

$$\begin{aligned} u(w) &= \frac{1}{2\pi} \int_0^{2\pi} u(w + re^{it}) dt \\ &= \frac{1}{2\pi} \left( \int_0^{t_0} u(w + re^{it}) dt + \int_{t_0}^{t_1} u(w + re^{it}) dt + \int_{t_1}^{2\pi} u(w + re^{it}) dt \right) \end{aligned}$$

All the integrands can be bounded by  $u(w)$ , for the middle integral we get a *strict* inequality. Hence

$$u(w) < \frac{1}{2\pi} \left( \int_0^{t_0} u(w) dt + \int_{t_0}^{t_1} u(w) dt + \int_{t_1}^{2\pi} u(w) dt \right) = u(w),$$

a contradiction. The same argument works if we assume that  $u$  has a relative minimum. But in this case there's actually a short cut: if  $u$  has a strong relative minimum then the harmonic function  $-u$  has a strong relative maximum, which we just showed cannot exist.  $\square$

*A look into the (not so distant) future.* We will see in Corollary 8.11 a variation of this theorem for a *weak relative maximum*  $w$ , in the sense that there exists a disk  $D = \{z \in \mathbb{C} : |z - w| < R\} \subset G$  such that all  $z \in D$  satisfy  $u(z) \leq u(w)$ . Corollary 8.11 says that if  $u$  is harmonic in the region  $G$ , then it does not have a *weak* relative maximum or minimum in  $G$ . A special yet important case of the above *maximum/minimum principle* is obtained when considering bounded regions. Corollary 8.11 implies that if  $u$  is harmonic in the closure of the bounded region  $G$  then

$$\max_{z \in G} u(z) = \max_{z \in \partial G} u(z) \quad \text{and} \quad \min_{z \in G} u(z) = \min_{z \in \partial G} u(z).$$

(Here  $\partial G$  denotes the boundary of  $G$ .) We'll exploit this fact in the next two corollaries.

**Corollary 6.7.** *Suppose  $u$  is harmonic in the closure of the bounded region  $G$ . If  $u$  is zero on  $\partial G$  then  $u$  is zero in  $G$ .*



*Proof.* By the remark we just made

$$u(z) \leq \max_{z \in G} u(z) = \max_{z \in \partial G} u(z) = \max_{z \in \partial G} 0 = 0$$

and

$$u(z) \geq \min_{z \in G} u(z) = \min_{z \in \partial G} u(z) = \min_{z \in \partial G} 0 = 0,$$

so  $u$  has to be zero in  $G$ .  $\square$

**Corollary 6.8.** *If two harmonic functions agree on the boundary of a bounded region then they agree in the region.*

*Proof.* Suppose  $u$  and  $v$  are harmonic in  $G \cup \partial G$  and they agree on  $\partial G$ . Then  $u - v$  is also harmonic in  $G \cup \partial G$  (Exercise 2) and  $u - v$  is zero on  $\partial G$ . Now apply the previous corollary.  $\square$

The last corollary states that if we know a harmonic function on the boundary of some region then we know it inside the region. One should remark, however, that this result is of a completely theoretical nature: it says nothing about how to extend a function given on the boundary of a region to the full region. This problem is called the *Dirichlet<sup>2</sup> problem* and has a solution for all simply-connected regions. There is a fairly simple formula (involving the so-called *Poisson<sup>3</sup> kernel*) if the region in question is a disk; for other regions one needs to find a *conformal map* to the unit disk. All of this is beyond the scope of these notes, we just remark that Corollary 6.8 says that the solution to the Dirichlet problem is unique.

## Exercises

1. Show that all partial derivatives of a harmonic function are harmonic.
2. Suppose  $u$  and  $v$  are harmonic, and  $c \in \mathbb{R}$ . Prove that  $u + cv$  is also harmonic.
3. Consider  $u(z) = u(x, y) = \ln(x^2 + y^2)$ .
  - (a) Show that  $u$  is harmonic in  $\mathbb{C} \setminus \{0\}$ .
  - (b) Prove that  $u$  is *not* the real part of a function which is holomorphic in  $\mathbb{C} \setminus \{0\}$ .
4. Let  $u(x, y) = e^x \sin y$ .
  - (a) Show that  $u$  is harmonic on  $\mathbb{C}$ .
  - (b) Find an entire function  $f$  such that  $\operatorname{Re}(f) = u$ .
5. Is it possible to find a real function  $v$  so that  $x^3 + y^3 + iv$  is holomorphic?

---

<sup>2</sup>For more information about Johann Peter Gustav Dirichlet (1805–1859), see <http://www-groups.dcs.st-and.ac.uk/~history/Biographies/Dirichlet.html>.

<sup>3</sup>For more information about Siméon Denis Poisson (1781–1840), see <http://www-groups.dcs.st-and.ac.uk/~history/Biographies/Poisson.html>.

# Chapter 7

## Power Series

*It is a pain to think about convergence but sometimes you really have to.*  
Sinai Robins

### 7.1 Sequences and Completeness

As in the real case (and there will be no surprises in this chapter of the nature ‘real versus complex’), a (*complex*) *sequence* is a function from the positive (sometimes the nonnegative) integers to the complex numbers. Its values are usually denoted by  $a_n$  (as opposed to, say,  $a(n)$ ) and we commonly denote the sequence by  $(a_n)_{n=1}^{\infty}$ ,  $(a_n)_{n \geq 1}$ , or simply  $(a_n)$ . The notion of convergence of a sequence is based on the following sibling of Definition 2.1.

**Definition 7.1.** Suppose  $(a_n)$  is a sequence and  $a \in \mathbb{C}$  such that for all  $\epsilon > 0$ , there is an integer  $N$  such that for all  $n \geq N$ , we have  $|a_n - a| < \epsilon$ . Then the sequence  $(a_n)$  is *convergent* and  $a$  is its *limit*, in symbols

$$\lim_{n \rightarrow \infty} a_n = a.$$

If no such  $a$  exists then the sequence  $(a_n)$  is *divergent*.

**Example 7.2.**  $\lim_{n \rightarrow \infty} \frac{i^n}{n} = 0$ : Given  $\epsilon > 0$ , choose  $N > 1/\epsilon$ . Then for any  $n \geq N$ ,

$$\left| \frac{i^n}{n} - 0 \right| = \left| \frac{i^n}{n} \right| = \frac{|i|^n}{n} = \frac{1}{n} \leq \frac{1}{N} < \epsilon.$$

**Example 7.3.** The sequence  $(a_n = i^n)$  diverges: Given  $a \in \mathbb{C}$ , choose  $\epsilon = 1/2$ . We consider two cases: If  $\operatorname{Re} a \geq 0$ , then for any  $N$ , choose  $n \geq N$  such that  $a_n = -1$ . (This is always possible since  $a_{4k+2} = i^{4k+2} = -1$  for any  $k \geq 0$ .) Then

$$|a - a_n| = |a + 1| \geq 1 > \frac{1}{2}.$$

If  $\operatorname{Re} a < 0$ , then for any  $N$ , choose  $n \geq N$  such that  $a_n = 1$ . (This is always possible since  $a_{4k} = i^{4k} = 1$  for any  $k > 0$ .) Then

$$|a - a_n| = |a - 1| \geq 1 > \frac{1}{2}.$$

The following limit laws are the relatives of the identities stated in Lemma 2.4.

**Lemma 7.4.** *Let  $(a_n)$  and  $(b_n)$  be convergent sequences and  $c \in \mathbb{C}$ .*

$$(a) \lim_{n \rightarrow \infty} a_n + c \lim_{n \rightarrow \infty} b_n = \lim_{n \rightarrow \infty} (a_n + c b_n).$$

$$(b) \lim_{n \rightarrow \infty} a_n \cdot \lim_{n \rightarrow \infty} b_n = \lim_{n \rightarrow \infty} (a_n \cdot b_n).$$

$$(c) \frac{\lim_{n \rightarrow \infty} a_n}{\lim_{n \rightarrow \infty} b_n} = \lim_{n \rightarrow \infty} \left( \frac{a_n}{b_n} \right).$$

*In the quotient law we have to make sure we do not divide by zero.*

*If  $f$  is continuous at  $a$  then*

$$\lim_{n \rightarrow \infty} f(a_n) = f(a) \quad \text{if} \quad \lim_{n \rightarrow \infty} a_n = a,$$

*where we require that  $a_n$  be in the domain of  $f$ .*

The most important property of the real number system is that we can, in many cases, determine that a sequence converges *without knowing the value of the limit*. In this sense we can use the sequence to define a real number.

**Definition 7.5.** A *Cauchy sequence* is a sequence  $(a_n)$  such that

$$\lim_{n \rightarrow \infty} |a_{n+1} - a_n| = 0.$$

We say a *metric space*  $X$  (which for us means  $\mathbb{Z}$ ,  $\mathbb{Q}$ ,  $\mathbb{R}$ , or  $\mathbb{C}$ ) is *complete* if, for any Cauchy sequence  $(a_n)$  in  $X$ , there is some  $a \in X$  such that  $\lim_{n \rightarrow \infty} a_n = a$ .

In other words, completeness means Cauchy sequences are guaranteed to converge. For example, the rational numbers are not complete: we can take a Cauchy sequence of rational numbers getting arbitrarily close to  $\sqrt{2}$ , which is not a rational number. However, each of  $\mathbb{Z}$ ,  $\mathbb{R}$ , and  $\mathbb{C}$  is complete. It is the completeness of the reals that allows us to know sequences converge without knowing their limits.

We will assume that the reals are complete as an axiom. There are many equivalent ways of formulating the completeness property for the reals, including:

**Axiom** (Monotone Sequence Property). *Any bounded monotone sequence converges.*

Notice that the Monotone Sequence Property implies the Least Upper Bound Property, which states that every non-empty set of real numbers with an upper bound in fact has a supremum, or least upper bound.

Remember that a sequence is monotone if it is either non-decreasing ( $x_{n+1} \geq x_n$ ) or non-increasing ( $x_{n+1} \leq x_n$ ).

**Example 7.6.** If  $0 \leq r < 1$  then  $\lim_{n \rightarrow \infty} r^n = 0$ : First, the sequence converges because it is decreasing and bounded below by 0. If the limit is  $L$  then, using the laws of limits, we get  $L = \lim_{n \rightarrow \infty} r^n = \lim_{n \rightarrow \infty} r^{n+1} = r \lim_{n \rightarrow \infty} r^n = rL$ . From  $L = rL$  we get  $(1 - r)L = 0$ , so  $L = 0$  since  $1 - r \neq 0$ .

The following is a consequence of the Monotone Sequence Property (via the Least Upper Bound Property), although it is often listed as a separate axiom:

**Theorem 7.7** (Archimedean<sup>1</sup> Property). *If  $x$  is any real number then there is an integer  $N$  which is greater than  $x$ .*

This essentially says that there are no infinities in the reals. Notice that this was already used in Example 7.2. For a proof see Exercise 5. It is interesting to see that the Archimedean principle underlies the construction of an infinite decimal expansion for any real number, while the monotone sequence property shows that any such infinite decimal expansion actually converges to a real number.

We close this discussion of limits with a pair of standard limits. The first of these can be established by calculus methods (like L'Hospital's rule, by treating  $n$  as the variable); both of them can be proved by more elementary considerations.

**Lemma 7.8.** (a) *Exponentials beat polynomials: for any polynomial  $p(n)$  and any  $b \in \mathbb{R}$  with  $|b| > 1$ ,  $\lim_{n \rightarrow \infty} \frac{p(n)}{b^n} = 0$ .*

(b) *Factorials beat exponentials: for any  $a \in \mathbb{R}$ ,  $\lim_{n \rightarrow \infty} \frac{a^n}{n!} = 0$ .*

Note this lemma also works for  $a, b \in \mathbb{C}$ .

## 7.2 Series

A *series* is a sequence  $(a_n)$  whose members are of the form  $a_n = \sum_{k=1}^n b_k$  (or  $a_n = \sum_{k=0}^n b_k$ ); here  $(b_k)$  is the *sequence of terms* of the series. The  $a_n = \sum_{k=1}^n b_k$  (or  $a_n = \sum_{k=0}^n b_k$ ) are the *partial sums* of the series. If we wanted to be lazy we would define convergence of a series simply by referring to convergence of the partial sums of the series – after all, we just defined series through sequences. However, there are some convergence features which take on special appearances for series, so we should mention them here explicitly. For starters, a series *converges* to the *limit* (or *sum*)  $a$  by definition if

$$\lim_{n \rightarrow \infty} a_n = \lim_{n \rightarrow \infty} \sum_{k=1}^n b_k = a.$$

To express this in terms of Definition 7.1, for any  $\epsilon > 0$  we have to find an  $N$  such that for all  $n \geq N$

$$\left| \sum_{k=1}^n b_k - a \right| < \epsilon.$$

In the case of a convergent series, we usually express its limit as  $a = \sum_{k=1}^{\infty} b_k$  or  $a = \sum_{k \geq 1} b_k$ .

---

<sup>1</sup>For more on Archimedes, see <http://en.wikipedia.org/wiki/Archimedes>. Archimedes attributes this property to Euxodus. For more on Euxodus, see <http://en.wikipedia.org/wiki/Euxodus>.

**Example 7.9.** Occasionally we can find the limit of a sequence by manipulating the partial sums:

$$\begin{aligned} \sum_{k \geq 1} \frac{1}{k(k+1)} &= \lim_{n \rightarrow \infty} \sum_{k=1}^n \left( \frac{1}{k} - \frac{1}{k+1} \right) \\ &= \lim_{n \rightarrow \infty} \left[ \left( 1 - \frac{1}{2} \right) + \left( \frac{1}{2} - \frac{1}{3} \right) + \left( \frac{1}{3} - \frac{1}{4} \right) + \cdots + \left( \frac{1}{n} - \frac{1}{n+1} \right) \right] \\ &= \lim_{n \rightarrow \infty} \left[ 1 - \frac{1}{2} + \frac{1}{2} - \frac{1}{3} + \frac{1}{3} - \frac{1}{4} + \cdots + \frac{1}{n} - \frac{1}{n+1} \right] \\ &= \lim_{n \rightarrow \infty} \left[ 1 - \frac{1}{n+1} \right] = 1. \end{aligned}$$

A series where most of the terms cancel like this is called a *telescoping series*.

Most of the time we need to use the completeness property to check convergence of a series, and it is fortunate that the monotone sequence property has a very convenient translation into the language of series of real numbers. The partial sums of a series form a nondecreasing sequence if the terms of the series are nonnegative, and this observation immediately yields:

**Lemma 7.10.** *If  $b_k$  are nonnegative real numbers then  $\sum_{k=1}^{\infty} b_k$  converges if and only if the partial sums are bounded.*

If  $b_k$  are nonnegative real numbers and the partial sums of the series  $\sum_{k=1}^{\infty} b_k$  are unbounded then the partial sums “converge” to infinity, so we can write  $\sum_{k=1}^{\infty} b_k = \infty$ . Using this terminology, we can rephrase Lemma 7.10 to say:  $\sum_{k=1}^{\infty} b_k$  converges in the reals if and only if it is finite.

We have already used the simple fact that convergence of a sequence  $(a_n)$  is equivalent to the convergence of  $(a_{n-1})$ , and both of these sequences have the same limit. If  $a_n$  is the  $n^{\text{th}}$  partial sum of the series  $\sum_{k \geq 1} b_k$  then  $a_n = a_{n-1} + b_n$ . From this we conclude:

**Lemma 7.11.** *If  $\sum_{k \geq 1} b_k$  converges then  $\lim_{n \rightarrow \infty} b_n = 0$ .*

The contrapositive of this lemma is often used, and is called the Test for Divergence:

**Lemma 7.12** (Test for Divergence). *If  $\lim_{n \rightarrow \infty} b_n \neq 0$ , then  $\sum_{k \geq 1} b_k$  diverges.*

A common mistake is to try to use the converse of this lemma, but the converse is false:

**Example 7.13.** The *harmonic series*  $\sum_{k \geq 1} \frac{1}{k}$  diverges (even though the limit of the general term is 0): If we assume the series converges, say to  $L$ , then we have

$$\begin{aligned} L &= 1 + \frac{1}{2} + \frac{1}{3} + \frac{1}{4} + \cdots \\ &= \left( 1 + \frac{1}{3} + \frac{1}{5} + \cdots \right) + \left( \frac{1}{2} + \frac{1}{4} + \frac{1}{6} + \cdots \right) \\ &> \left( \frac{1}{2} + \frac{1}{4} + \frac{1}{6} + \cdots \right) + \left( \frac{1}{2} + \frac{1}{4} + \frac{1}{6} + \cdots \right) \\ &= \frac{1}{2} \left( 1 + \frac{1}{2} + \frac{1}{3} + \frac{1}{4} + \cdots \right) + \frac{1}{2} \left( 1 + \frac{1}{2} + \frac{1}{3} + \frac{1}{4} + \cdots \right) \\ &= \frac{1}{2}L + \frac{1}{2}L = L. \end{aligned}$$

Here the inequality comes from  $\frac{1}{k} > \frac{1}{k+1}$  applied to each term in the first sum in parentheses. But now we have  $L > L$ , which is impossible.

There is one notion of convergence that's special to series: we say that  $\sum_{k \geq 1} c_k$  converges *absolutely* if  $\sum_{k \geq 1} |c_k| < \infty$ . Be careful: We are defining the phrase “converges absolutely,” but this definition does not say anything about convergence of the series  $\sum_{k \geq 1} c_k$ ; we need a proof:

**Theorem 7.14.** *If a series converges absolutely then it converges.*

*Proof.* First consider the case when the terms  $c_k$  are real. Define  $c_k^+$  to be  $c_k$  if  $c_k \geq 0$ , or 0 if  $c_k < 0$ . Then  $c_k^+ \geq 0$  and  $\sum_{k \geq 1} c_k^+ \leq \sum_{k \geq 1} |c_k| < \infty$  so  $\sum_{k \geq 1} c_k^+$  converges; let  $P$  be its limit. Similarly, define  $c_k^-$  to be  $-c_k$  if  $c_k \leq 0$ , or 0 if  $c_k > 0$ . Then  $c_k^- \geq 0$  and  $\sum_{k \geq 1} c_k^- \leq \sum_{k \geq 1} |c_k| < \infty$  so  $\sum_{k \geq 1} c_k^-$  converges; let  $N$  be its limit. Since  $c_k = c_k^+ - c_k^-$  we see that  $\sum_{k \geq 1} c_k$  converges to  $P - N$ .

In case  $c_k$  is complex, write  $c_k = a_k + ib_k$  where  $a_k$  and  $b_k$  are real. Then  $\sum_{k \geq 1} |a_k| \leq \sum_{k \geq 1} |c_k| < \infty$  and  $\sum_{k \geq 1} |b_k| \leq \sum_{k \geq 1} |c_k| < \infty$ . By what we just proved, both  $\sum_{k \geq 1} a_k$  and  $\sum_{k \geq 1} b_k$  converge to real numbers, say,  $A$  and  $B$ . But then  $\sum_{k \geq 1} c_k$  converges to  $A + iB$ .  $\square$

Another common mistake is to try to use the converse of this theorem, but the converse is false:

**Example 7.15.** The *alternating harmonic series*  $\sum_{k \geq 1} \frac{(-1)^{k+1}}{k}$  converges, but not absolutely: This series does not converge absolutely, according to the previous example. To see that it does converge, rewrite it as follows:

$$\begin{aligned} \sum_{k \geq 1} \frac{(-1)^{k+1}}{k} &= 1 - \frac{1}{2} + \frac{1}{3} - \frac{1}{4} + \frac{1}{5} - \frac{1}{6} + \dots \\ &= \left(1 - \frac{1}{2}\right) + \left(\frac{1}{3} - \frac{1}{4}\right) + \left(\frac{1}{5} - \frac{1}{6}\right) + \dots \end{aligned}$$

(Technically, there is a small detail to be checked here, since we are effectively ignoring half the partial sums of the original series. See Exercise 14.) The reader can verify the inequality  $2k(2k-1) \geq k(k+1)$  for  $k > 1$ , so the general term satisfies

$$\frac{1}{2k-1} - \frac{1}{2k} = \frac{1}{2k(2k-1)} \leq \frac{1}{k(k+1)},$$

so the series converges by comparison with the telescoping series of Example 7.9.

For the rest of this book we shall be concerned almost exclusively with series which converge absolutely. Hence checking convergence of a series is usually a matter of verifying that a series of nonnegative reals is finite. We have already used the technique of comparing a series to a series which is known to converge; this is often called a “comparison test.” Some variants of the comparison test will appear when we look at power series. One handy test is the following:

**Lemma 7.16** (Integral Test). *Suppose  $f$  is a non-increasing, positive function defined on  $[1, \infty)$ . Then*

$$\int_1^\infty f(t) dt \leq \sum_{k=1}^\infty f(k) \leq f(1) + \int_1^\infty f(t) dt$$

This is immediate from a picture: the integral of  $f(t)$  on the interval  $[k, k + 1]$  is bounded between  $f(k)$  and  $f(k + 1)$ . Adding the pieces gives the inequalities above for the  $N^{\text{th}}$  partial sum versus the integrals from 1 to  $N$  and from 1 to  $N + 1$ , and the inequality persists in the limit.

**Example 7.17.**  $\sum_{k \geq 1} \frac{1}{k^p}$  converges if  $p > 1$  and diverges if  $p \leq 1$ .

To summarize, when testing the convergence of a series we have: the Test for Divergence, the Comparison Test, and the Integral Test, as well as three related tests from calculus: the Limit Comparison Test, the Root Test, and the Ratio Test.

### 7.3 Sequences and Series of Functions

The fun starts when one studies sequences  $(f_n)$  of functions  $f_n$ . We say that such a sequence *converges at*  $z_0$  if the sequence (of complex numbers)  $(f_n(z_0))$  converges. If a sequence of functions,  $(f_n)$ , converges at all  $z$  in some subset  $G \subseteq \mathbb{C}$  then we say that  $(f_n)$  *converges pointwise on*  $G$ . So far nothing new; but this notion of convergence does not really catch the spirit of the function as a whole.

**Definition 7.18.** Suppose  $(f_n)$  and  $f$  are functions defined on  $G \subseteq \mathbb{C}$ . If for all  $\epsilon > 0$  there is an  $N$  such that for all  $z \in G$  and for all  $n \geq N$  we have

$$|f_n(z) - f(z)| < \epsilon$$

then  $(f_n)$  *converges uniformly in*  $G$  to  $f$ .

What's the big deal about uniform versus pointwise convergence? It is easiest to describe the difference with the use of quantifiers, namely  $\forall$  denoting “for all” and  $\exists$  denoting “there is.” Pointwise convergence on  $G$  means

$$(\forall \epsilon > 0) (\forall z \in G) (\exists N : n \geq N \Rightarrow |f_n(z) - f(z)| < \epsilon),$$

whereas uniform convergence on  $G$  translates into

$$(\forall \epsilon > 0) (\exists N : (\forall z \in G) n \geq N \Rightarrow |f_n(z) - f(z)| < \epsilon).$$

No big deal—we only exchanged two of the quantifiers. In the first case,  $N$  may well depend on  $z$ , in the second case we need to find an  $N$  which works for all  $z \in G$ . And this can make all the difference . . .

The first example illustrating this difference says in essence that if we have a sequence of functions  $(f_n)$  which converges uniformly on  $G$  then for all  $z_0 \in G$

$$\lim_{n \rightarrow \infty} \lim_{z \rightarrow z_0} f_n(z) = \lim_{z \rightarrow z_0} \lim_{n \rightarrow \infty} f_n(z).$$

We will need similar interchanges of limits constantly.

**Proposition 7.19.** *Suppose  $(f_n)$  is a sequence of continuous functions on the region  $G$  converging uniformly to  $f$  on  $G$ . Then  $f$  is continuous on  $G$ .*

*Proof.* Let  $z_0 \in G$ ; we will prove that  $f$  is continuous at  $z_0$ . By uniform convergence, given  $\epsilon > 0$ , there is an  $N$  such that for all  $z \in G$  and all  $n \geq N$

$$|f_n(z) - f(z)| < \frac{\epsilon}{3}.$$

Now we make use of the continuity of the  $f_n$ 's. This means that given (the same)  $\epsilon > 0$ , there is a  $\delta > 0$  such that whenever  $|z - z_0| < \delta$  we have

$$|f_n(z) - f_n(z_0)| < \frac{\epsilon}{3}.$$

All that's left is putting those two inequalities together: by the triangle inequality

$$\begin{aligned} |f(z) - f(z_0)| &= |f(z) - f_n(z) + f_n(z) - f_n(z_0) + f_n(z_0) - f(z_0)| \\ &\leq |f(z) - f_n(z)| + |f_n(z) - f_n(z_0)| + |f_n(z_0) - f(z_0)| \\ &< \epsilon, \end{aligned}$$

that is,  $f$  is continuous at  $z_0$ . □

Once we know the above result about continuity, we can ask about integration of series of functions. The next theorem should come as no surprise, however, its consequences (which we will only see in the next chapter) are wide ranging.

**Proposition 7.20.** *Suppose  $f_n$  are continuous on the smooth curve  $\gamma$  and converge uniformly on  $\gamma$  to  $f$ . Then*

$$\lim_{n \rightarrow \infty} \int_{\gamma} f_n = \int_{\gamma} f.$$

*Proof.* By Proposition 4.4(d), we can estimate

$$\left| \int_{\gamma} f_n - \int_{\gamma} f \right| = \left| \int_{\gamma} f_n - f \right| \leq \max_{z \in \gamma} |f_n(z) - f(z)| \text{length}(\gamma).$$

But  $f_n \rightarrow f$  uniformly on  $\gamma$ , and we can make  $\max_{z \in \gamma} |f_n(z) - f(z)|$  as small as we like. □

Since uniform convergence is often of critical importance, we give two practical tests: one arguing for uniformity and the other against. They are formulated for sequences that converge to 0. If a sequence  $g_n$  converges to a function  $g$  then we can usually apply these tests to  $f_n = g - g_n$ , which does converge to 0.

**Lemma 7.21.** *If  $f_n$  is a sequence of functions and  $M_n$  is a sequence of constants so that  $M_n$  converges to 0 and  $|f_n(z)| \leq M_n$  for all  $z$  in the set  $G$   $f_n$  converges uniformly to 0 on  $G$ .*

For example,  $|z^n| \leq r^n$  if  $z$  is in the closed disk  $\bar{D}_r(0)$ , and  $r^n \rightarrow 0$  if  $r < 1$ , so  $z^n \rightarrow 0$  uniformly in  $\bar{D}_r(0)$  if  $r < 1$ .

**Lemma 7.22.** *If  $f_n$  is a sequence of functions which converges uniformly to 0 on a set  $G$  and  $z_n$  is any sequence in  $G$  then the sequence  $f_n(z_n)$  converges to 0.*



This is most often used to prove *non-uniform* convergence. For example, let  $f_n(z) = z^n$  and let  $G$  be the open unit disk  $D_1(0)$ . Then  $|z| < 1$  if  $z$  is in  $G$ , so  $|z|^n \rightarrow 0$ , and so  $z^n \rightarrow 0$ . However, let  $z_n = \exp(-\frac{1}{n})$ . Then  $z_n$  is in  $G$  but  $f_n(z_n) = e^{-1}$  so  $f_n(z_n)$  does not converge to 0. Therefore  $z^n$  does not converge uniformly to 0 on  $D_1(0)$ .

All of these notions for sequences of functions go verbatim for series of functions. Here we also have a notion of absolute convergence (which can be combined with uniform convergence). There is an important result about series of functions, often called the *Weierstraß M-test*.

**Proposition 7.23.** *Suppose  $(f_k)$  are continuous on the region  $G$ ,  $|f_k(z)| \leq M_k$  for all  $z \in G$ , and  $\sum_{k \geq 1} M_k$  converges. Then  $\sum_{k \geq 1} f_k$  converges absolutely and uniformly in  $G$ .*

*Proof.* For each fixed  $z$  we have  $\sum_{k \geq 1} |f_k(z)| \leq \sum_{k \geq 1} M_k < \infty$ , so  $\sum_{k \geq 1} f_k(z)$  converges; call the limit  $f(z)$ . This defines a function  $f$  on  $G$ . To see that  $f_n$  converges uniformly to  $f$ , suppose  $\epsilon > 0$ . Since  $\sum_{k \geq 1} M_k$  converges there is  $N$  so that

$$\sum_{k > n} M_k = \sum_{k=1}^{\infty} M_k - \sum_{k=1}^n M_k < \epsilon$$

for all  $n > N$ . Then, for any  $z$  in  $G$ , if  $n \geq N$  then

$$\left| f(z) - \sum_{k=1}^n f_k(z) \right| = \left| \sum_{k > n} f_k(z) \right| \leq \sum_{k > n} |f_k(z)| \leq \sum_{k > n} M_k < \epsilon$$

and this satisfies the definition of uniform convergence.  $\square$

A good example of the difference between pointwise convergence and uniform convergence can be seen in the following example.

**Example 7.24.** For simplicity and so we can draw the appropriate pictures, we restrict our attention to the real axis (using  $x$  instead of  $z$ ), although this example holds for complex-defined functions. Consider the sequence of functions  $(f_n)$  defined by  $f_n(x) := \sin^n(x)$ , on the interval  $[0, \pi]$ . On this interval, for all  $n$  and all  $x$  we have  $0 \leq f_n(x) \leq 1$ , with  $f_n(x) = 1$  if and only if  $x = \pi/2$ . It follows that, for any fixed  $x \in [0, \pi]$ , the sequence  $(f_n(x))$  converges to 1 if  $x = \pi/2$  or to 0 if  $x \neq \pi/2$ . Thus, the sequence  $(f_n)$  converges pointwise to the function  $f$  defined by

$f(x) := \begin{cases} 1 & \text{if } x = \pi/2 \\ 0 & \text{if } x \neq \pi/2 \end{cases}$ . Because the functions  $f_n$  are all continuous but  $f$  is not, we can already

see by Proposition 7.19 that the convergence must not be uniform. To visualize this, consider Figure 7.1. Away from  $x = \pi/2$ , pointwise convergence to  $f$  is seen by the fact that the functions  $f_n$  are getting closer and closer to 0. Non-uniform convergence is illustrated by the fact that, as  $x$  gets closer and closer to  $\pi/2$ , the functions  $f$  take longer and longer to get to 0.

We end this section by noting that everything we've developed here could have been done in greater generality - for instance, for functions from  $\mathbb{R}^n$  or  $\mathbb{C}^n$  to  $\mathbb{R}^m$  or  $\mathbb{C}^m$ .

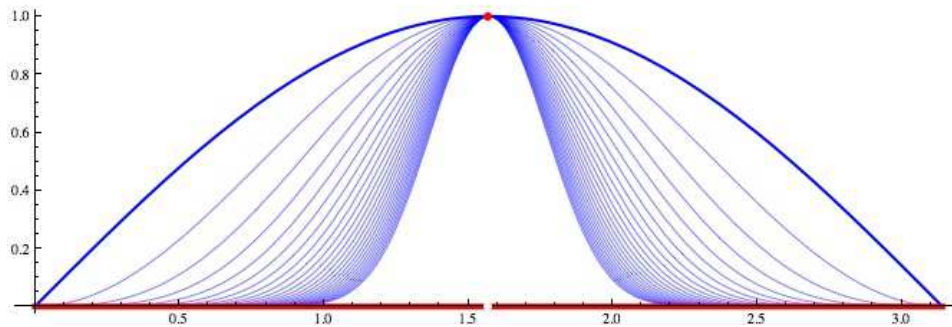

Figure 7.1: The graph of the functions  $f_n(x) := \sin^n(x)$ , showing the difference between pointwise and uniform convergence.

## 7.4 Region of Convergence

For the remainder of this chapter (indeed, these lecture notes) we concentrate on some very special series of functions.

**Definition 7.25.** A *power series centered at  $z_0$*  is a series of functions of the form

$$\sum_{k \geq 0} c_k (z - z_0)^k.$$

The fundamental example of a power series is the *geometric series*, for which all  $c_k = 1$ .

**Lemma 7.26.** The geometric series  $\sum_{k \geq 0} z^k$  converges absolutely for  $|z| < 1$  to the function  $1/(1 - z)$ . The convergence is uniform on any set of the form  $\{z \in \mathbb{C} : |z| \leq r\}$  for any  $r < 1$ .

*Proof.* Fix an  $r < 1$ , and let  $D = \{z \in \mathbb{C} : |z| \leq r\}$ . We will use Proposition 7.23 with  $f_k(z) = z^k$  and  $M_k = r^k$ . Hence the uniform convergence on  $D$  of the geometric series will follow if we can show that  $\sum_{k \geq 0} r^k$  converges. But this is straightforward: the partial sums of this series can be written as

$$\sum_{k=0}^n r^k = 1 + r + \cdots + r^{n-1} + r^n = \frac{1 - r^{n+1}}{1 - r},$$

whose limit as  $n \rightarrow \infty$  exists because  $r < 1$ . Hence, by Proposition 7.23, the geometric series converges absolutely and uniformly on any set of the form  $\{z \in \mathbb{C} : |z| \leq r\}$  with  $r < 1$ . Since  $r$  can be chosen arbitrarily close to 1, we have absolute convergence for  $|z| < 1$ . It remains to show that for those  $z$  the limit function is  $1/(1 - z)$ , which follows by

$$\sum_{k \geq 0} z^k = \lim_{n \rightarrow \infty} \sum_{k=0}^n z^k = \lim_{n \rightarrow \infty} \frac{1 - z^{n+1}}{1 - z} = \frac{1}{1 - z}. \quad \square$$

By comparing a general power series to a geometric series we can give a complete description of its region of convergence.

**Theorem 7.27.** Any power series  $\sum_{k \geq 0} c_k (z - z_0)^k$  has a radius of convergence  $R$ . By this we mean that  $R$  is a nonnegative real number, or  $\infty$ , satisfying the following.

- (a) If  $r < R$  then  $\sum_{k \geq 0} c_k(z - z_0)^k$  converges absolutely and uniformly on the closed disk  $\bar{D}_r(z_0)$  of radius  $r$  centered at  $z_0$ .
- (b) If  $|z - z_0| > R$  then the sequence of terms  $c_k(z - z_0)^k$  is unbounded, so  $\sum_{k \geq 0} c_k(z - z_0)^k$  does not converge.

The open disk  $D_R(z_0)$  in which the power series converges absolutely is the *region of convergence*. (If  $R = \infty$  then  $D_R(z_0)$  is the entire complex plane, and if  $R = 0$  then  $D_R(z_0)$  is the empty set.) By way of Proposition 7.19, this theorem immediately implies the following.

**Corollary 7.28.** *Suppose the power series  $\sum_{k \geq 0} c_k(z - z_0)^k$  has radius of convergence  $R$ . Then the series represents a function which is continuous on  $D_R(z_0)$ .*

While we're at it, we might as well state what Proposition 7.20 implies for power series.

**Corollary 7.29.** *Suppose the power series  $\sum_{k \geq 0} c_k(z - z_0)^k$  has radius of convergence  $R$  and  $\gamma$  is a smooth curve in  $D_R(z_0)$ . Then*

$$\int_{\gamma} \sum_{k \geq 0} c_k(z - z_0)^k dz = \sum_{k \geq 0} c_k \int_{\gamma} (z - z_0)^k dz.$$

In particular, if  $\gamma$  is closed then  $\int_{\gamma} \sum_{k \geq 0} c_k(z - z_0)^k dz = 0$ .

*Proof of Theorem 7.27.* Define  $C$  to be the set of positive real numbers for which the series  $\sum_{k \geq 0} c_k t^k$  converges, and define  $D$  to be the set of positive real numbers for which it diverges. Clearly every positive real number is in either  $C$  or  $D$ , and these sets are disjoint. First we establish three facts about these sets.

(\*) If  $t \in C$  and  $r < t$  then  $r \in C$ , and  $\sum_{k \geq 0} c_k(z - z_0)^k$  converges absolutely and uniformly on  $\bar{D}_r(z_0)$ . To prove this, note that  $\sum_{k \geq 0} c_k t^k$  converges so  $c_k t^k \rightarrow 0$  as  $k \rightarrow \infty$ . In particular, this sequence is bounded, so  $|c_k| t^k \leq M$  for some constant  $M$ . Now if  $z \in \bar{D}_r(z_0)$  we have  $|c_k(z - z_0)^k| \leq |c_k| r^k$  and

$$\sum_{k \geq 0} |c_k| r^k = \sum_{k \geq 0} |c_k| t^k \left(\frac{r}{t}\right)^k \leq \sum_{k \geq 0} M \left(\frac{r}{t}\right)^k = M \sum_{k \geq 0} \left(\frac{r}{t}\right)^k = \frac{M}{1 - r/t} < \infty.$$

At the last step we recognized the geometric series, which converges since  $0 \leq r < t$ , and so  $0 \leq r/t < 1$ . This shows that  $r \in C$ , and uniform and absolute convergence on  $\bar{D}_r(z_0)$  follows from the Weierstraß  $M$ -test.

(\*\*) If  $t \in D$  and  $r > t$  then  $r \in D$ , and  $\sum_{k \geq 0} c_k(z - z_0)^k$  diverges on the complement of  $D_r(z_0)$  - that is, for  $|z - z_0| \geq r$ . To prove this, assume that  $c_k r^k$  is bounded, so  $|c_k| r^k \leq M$  for some constant  $M$ . But now exactly the same argument as in (\*), but interchanging  $r$  and  $t$ , shows that  $\sum_{k \geq 0} c_k t^k$  converges, contradicting the assumption that  $t$  is in  $D$ .

(\*\*\*) There is an extended real number  $R$ , satisfying  $0 \leq R \leq \infty$ , so that  $0 < r < R$  implies  $r \in C$  and  $R < r < \infty$  implies  $r \in D$ . Notice that  $R = 0$  works if  $C$  is empty, and  $R = \infty$  works if  $D$  is empty; so we assume neither is empty and we start with  $a_0$  in  $C$  and  $b_0$  in  $D$ . It is immediate from (\*) or (\*\*) that  $a_0 < b_0$ . We shall define sequences  $a_n$  in  $C$  and  $b_n$  in  $D$  which “zero in” on  $R$ . First, let  $m_0$  be the midpoint of the segment  $[a_0, b_0]$ , so  $m_0 = (a_0 + b_0)/2$ . If  $m_0$  lies in  $C$  then

we define  $a_1 = m_0$  and  $b_1 = b_0$ ; but if  $m_0$  lies in  $D$  then we define  $a_1 = a_0$  and  $b_1 = m_0$ . Note that, in either case, we have  $a_0 \leq a_1 < b_1 \leq b_0$ ,  $a_1$  is in  $C$ , and  $b_1$  is in  $D$ . Moreover,  $a_1$  and  $b_1$  are closer together than  $a_0$  and  $b_0$ ; in fact,  $b_1 - a_1 = (b_0 - a_0)/2$ . We repeat this procedure to define  $a_2$  and  $b_2$  within the interval  $[a_1, b_1]$ , and so on. Summarizing, we have

$$\begin{aligned} a_n &\leq a_{n+1} & a_n &\in C \\ b_n &\geq b_{n+1} & b_n &\in D \\ a_n &< b_n \\ b_n - a_n &= (b_0 - a_0)/2^n \end{aligned}$$

The sequences  $a_n$  and  $b_n$  are monotone and bounded (by  $a_0$  and  $b_0$ ) so they have limits, and these limits are the same since  $\lim_{n \rightarrow \infty} (b_n - a_n) = \lim_{n \rightarrow \infty} (b_0 - a_0)/2^n = 0$ . We define  $R$  to be this limit. If  $0 < r < R$  then  $r < a_n$  for all sufficiently large  $n$ , since  $a_n$  converges to  $R$ , so  $r$  is in  $C$  by (\*). On the other hand, if  $R < r$  then  $b_n < r$  for all sufficiently large  $n$ , so  $r$  is in  $D$  by (\*\*). Thus  $R$  verifies the statement (\*\*\*) .

To prove Theorem 7.27, first assume  $r < R$  and choose  $t$  so that  $r < t < R$ . Then  $t \in C$  by (\*\*\*) , so part (a) of 7.27 follows from (\*). Similarly, if  $r = |z - z_0| > R$  then choose  $t$  so that  $R < t < r$ . Then  $t \in D$  by (\*\*\*) , so part (b) of 7.27 follows from (\*\*).  $\square$

It is worth mentioning the following corollary, which reduces the calculation of the radius of convergence to examining the limiting behavior of the terms of the series.

**Corollary 7.30.**  $|c_k| r^k \rightarrow 0$  for  $0 \leq r < R$  but  $|c_k| r^k$  is unbounded for  $r > R$ .

**Warning:** Neither Theorem 7.27 nor Corollary 7.30 says anything about convergence on the circle  $|z - z_0| = R$ .

**Example 7.31.** Consider the function  $f(z) = \exp(z)$ . You may recall from calculus that the real-defined, real-valued function  $e^x$  has an expansion as the power series  $\sum_{k \geq 0} \frac{x^k}{k!}$ . In fact, a similar expression holds for the complex-defined, complex-valued  $f(z)$ . Let  $g(z) = \sum_{k \geq 0} \frac{z^k}{k!}$ . Then

$$g'(z) = \frac{d}{dz} \sum_{k \geq 0} \frac{z^k}{k!} = \sum_{k \geq 0} \frac{d}{dz} \frac{z^k}{k!} = \sum_{k \geq 1} \frac{z^{k-1}}{(k-1)!} = \sum_{k \geq 0} \frac{z^k}{k!} = g(z).$$

Thus,  $g(z)$  has the correct derivative. The question still remains whether  $f(z) = g(z)$  or not. To see that  $f(z) = g(z)$ , first note that

$$\frac{1}{f(z)} = \frac{1}{\exp(z)} = \exp(-z) = f(-z).$$

Thus, the function  $f(-z)g(z)$  has 0 derivative:

$$\frac{d}{dz} [f(-z)g(z)] = -f'(-z)g(z) + f(-z)g'(z) = -f(-z)g(z) + f(-z)g(z) = 0.$$

This means that  $\frac{g(z)}{f(z)} = f(-z)g(z) = c$  for some constant  $c \in \mathbb{C}$ . Evaluating at  $z = 0$ , we see  $c = 1$ , so  $g(z) = f(z)$  as desired.

We use the Ratio Test to determine the radius of convergence. Since

$$\left| \frac{x^{k+1}}{(k+1)!} \cdot \frac{k!}{x^k} \right| = \left| \frac{x}{k+1} \right| = \frac{|x|}{k+1} \rightarrow 0$$

as  $k \rightarrow \infty$ , the power series converges absolutely for all  $x$ . The radius of convergence is  $R = \infty$ . The region of convergence is all of  $\mathbb{C}$ , the "disk of radius infinity" about the origin (the center of the series).

There are many operations we may perform on series. We may add constants and polynomials to power series. We may rearrange the terms of a series in the case that the series converges absolutely. That absolute convergence is both necessary and sufficient for rearrangement is left as an exercise. Thus, we may add two power series together on a common region of convergence and rearrange their sum to collect coefficients of the same degree together, as the next example demonstrates. We have seen that we may differentiate and integrate power series. We may also multiply series by constants, or multiply power series by polynomials. In fact, we may multiply power series together on their common region of convergence. We leave it as an exercise to determine a formula for multiplying power series together.

**Example 7.32.** We can use the power series expansion for  $\exp(z)$  to find a power series expansion of the trigonometric functions. For instance, consider  $f(z) = \sin(z)$ . Then

$$\begin{aligned} f(z) = \sin z &= \frac{1}{2i} (e^{iz} - e^{-iz}) \\ &= \frac{1}{2i} \left( \sum_{k \geq 0} \frac{(iz)^k}{k!} - \sum_{k \geq 0} \frac{(-iz)^k}{k!} \right) \\ &= \frac{1}{2i} \sum_{k \geq 0} \frac{1}{k!} \left( (iz)^k - (-1)^k (iz)^k \right) \\ &= \frac{1}{2i} \sum_{k \geq 0, k \text{ odd}} \frac{2i^k z^k}{k!} \\ &= \frac{1}{2i} \sum_{l \geq 0} \frac{2i^{2l+1} z^{2l+1}}{(2l+1)!} \\ &= \sum_{l \geq 0} \frac{i^{2l+2} z^{2l+1}}{(2l+1)!} \\ &= \sum_{l \geq 0} \frac{(-1)^{l+1}}{z^{2l+1}} (2l+1)! \\ &= z - \frac{z^3}{3!} + \frac{z^5}{5!} - \frac{z^7}{7!} + \dots \end{aligned}$$

Note that we are allowed to rearrange the terms of the two added sums because the corresponding series have infinite radius of convergence.

**Exercises**

1. Let  $(a_n)$  be a sequence. A point  $a$  is an *accumulation point* of the sequence if: for every  $\epsilon > 0$  and every  $N \in \mathbb{N}$  there exists some  $n > N$  such that  $|a_n - a| < \epsilon$ . Prove that if a sequence has more than one accumulation point then the sequence diverges.

2. For each of the sequences, prove convergence/divergence. If the sequence converges, find the limit.

(a)  $a_n = e^{i\pi n/4}$ .

(b)  $\frac{(-1)^n}{n}$ .

(c)  $\cos n$ .

(d)  $2 - \frac{in^2}{2n^2+1}$ .

(e)  $\sin\left(\frac{1}{n}\right)$ .

3. Determine whether each of the following series converges or diverges.

(a)  $\sum_{n \geq 1} \left(\frac{1+i}{\sqrt{3}}\right)^n$

(b)  $\sum_{n \geq 1} n \left(\frac{1}{i}\right)^n$

(c)  $\sum_{n \geq 1} \left(\frac{1+2i}{\sqrt{5}}\right)^n$

(d)  $\sum_{n \geq 1} \frac{1}{n^3 + i^n}$

4. Show that the limit of a convergent sequence is unique.

5. Derive the Archimedean Property from the monotone sequence property.

6. Prove:

(a)  $\lim_{n \rightarrow \infty} a_n = a \implies \lim_{n \rightarrow \infty} |a_n| = |a|$ .

(b)  $\lim_{n \rightarrow \infty} a_n = 0 \iff \lim_{n \rightarrow \infty} |a_n| = 0$ .

7. Prove Lemma 7.8.

8. Prove:  $(c_n)$  converges if and only if  $(\operatorname{Re} c_n)$  and  $(\operatorname{Im} c_n)$  converge.

9. Prove Lemma 7.4.

10. Prove that  $\mathbb{Z}$  is complete.

11. Use the fact that  $\mathbb{R}$  is complete to prove that  $\mathbb{C}$  is complete.

12. Suppose  $a_n \leq b_n \leq c_n$  for all  $n$  and  $\lim_{n \rightarrow \infty} a_n = L = \lim_{n \rightarrow \infty} c_n$ . Prove that  $\lim_{n \rightarrow \infty} b_n = L$ . This is called the Squeeze Theorem, and is useful in testing a sequence for convergence.

13. Find  $\sup \{ \operatorname{Re}(e^{2\pi it}) : t \in \mathbb{Q} \setminus \mathbb{Z} \}$ .

14. Suppose that the terms  $c_n$  converge to zero, and show that  $\sum_{n=0}^{\infty} c_n$  converges if and only if  $\sum_{k=0}^{\infty} (c_{2k} + c_{2k+1})$  converges. Moreover, if the two series converge then they have the same limit. Also, give an example where  $c_n$  does not converge to 0 and one series diverges while the other converges.
15. Prove that the series  $\sum_{k \geq 1} b_k$  converges if and only if  $\lim_{n \rightarrow \infty} \sum_{k=n}^{\infty} b_k = 0$ .
16. (a) Show that  $\sum_{k \geq 1} \frac{1}{2^k} = 1$ . One way to do this is to write  $\frac{1}{2^k}$  as a difference of powers of 2 so that you get a telescoping series.  
 (b) Show that  $\sum_{k \geq 1} \frac{k}{k^2+1}$  diverges. (*Hint*: compare the general term to  $\frac{1}{2k}$ .)  
 (c) Show that  $\sum_{k \geq 1} \frac{k}{k^3+1}$  converges. (*Hint*: compare the general term to  $\frac{1}{k^2}$ .)
17. Discuss the convergence of  $\sum_{k \geq 0} z^k$  for  $|z| = 1$ .
18. Prove Lemma 7.21.
19. Prove Lemma 7.22.
20. Where do the following sequences converge pointwise? Do they converge uniformly on this domain?  
 (a)  $(nz^n)$ .  
 (b)  $\left(\frac{z^n}{n}\right)$  for  $n > 0$ .  
 (c)  $\left(\frac{1}{1+nz}\right)$ , defined on  $\{z \in \mathbb{C} : \operatorname{Re} z \geq 0\}$ .
21. Let  $f_n(x) = n^2 x e^{-nx}$ .  
 (a) Show that  $\lim_{n \rightarrow \infty} f_n(x) = 0$  for all  $x \geq 0$ . Treat  $x = 0$  as a special case; for  $x > 0$  you can use L'Hospital's rule—but remember that  $n$  is the variable, not  $x$ .  
 (b) Find  $\lim_{n \rightarrow \infty} \int_0^1 f_n(x) dx$ . (*Hint*: the answer is *not* 0.)  
 (c) Why doesn't your answer to part (b) violate Proposition 7.20?
22. Prove that absolute convergence is a sufficient and necessary condition to be able to arbitrarily rearrange the terms of a series without changing the sum.
23. Derive a formula for the product of two power series.
24. Find a power series (and determine its radius of convergence) of the following functions.  
 (a)  $\frac{1}{1+4z}$ .  
 (b)  $\frac{1}{3-\frac{z}{2}}$ .  
 (c)  $\frac{z^2}{(4-z)^2}$  for  $|z| < 4$
25. Find a power series representation about the origin of each of the following functions.  
 (a)  $\cos z$

- (b)  $\cos(z^2)$   
 (c)  $z^2 \sin z$   
 (d)  $(\sin z)^2$
26. (a) Suppose that the sequence  $c_k$  is bounded and show that the radius of convergence of  $\sum_{k \geq 0} c_k (z - z_0)^k$  is at least 1.  
 (b) Suppose that the sequence  $c_k$  does not converge to 0 and show that the radius of convergence of  $\sum_{k \geq 0} c_k (z - z_0)^k$  is at most 1.
27. Find the power series centered at 1 for the following functions, and compute their radius of convergence:
- (a)  $\frac{1}{z}$ .  
 (b)  $\text{Log } z$ .
28. Use the Weierstraß  $M$ -test to show that each of the following series converges uniformly on the given domain:
- (a)  $\sum_{k \geq 1} \frac{z^k}{k^2}$  on  $\bar{D}_1(0)$ .  
 (b)  $\sum_{k \geq 0} \frac{1}{z^k}$  on  $\{z: |z| \geq 2\}$ .  
 (c)  $\sum_{k \geq 0} \frac{z^k}{z^k + 1}$  on  $\bar{D}_r(0)$ , where  $0 \leq r < 1$ .
29. Suppose  $L = \lim_{k \rightarrow \infty} |c_k|^{1/k}$  exists. Show that  $\frac{1}{L}$  is the radius of convergence of  $\sum_{k \geq 0} c_k (z - z_0)^k$ . (Use the natural interpretations if  $L = 0$  or  $L = \infty$ .)
30. Find the radius of convergence for each of the following series.
- (a)  $\sum_{k \geq 0} a^{k^2} z^k$ ,  $a \in \mathbb{C}$ .  
 (b)  $\sum_{k \geq 0} k^n z^k$ ,  $n \in \mathbb{Z}$ .  
 (c)  $\sum_{k \geq 0} z^{k!}$ .  
 (d)  $\sum_{k \geq 1} \frac{(-1)^k}{k} z^{k(k+1)}$ .  
 (e)  $\sum_{k \geq 1} \frac{z^k}{k^k}$ .  
 (f)  $\sum_{k \geq 0} \cos(k) z^k$ .



$$(g) \sum_{k \geq 0} 4^k (z - 2)^k.$$

31. Find a function in “closed form” (i.e. not a power series) representing each of the following series.

$$(a) \sum_{k \geq 0} \frac{z^{2k}}{k!}$$

$$(b) \sum_{k \geq 1} k(z - 1)^{k-1}$$

$$(c) \sum_{k \geq 2} k(k - 1)z^k$$

32. Define the functions  $f_n(t) = \frac{1}{n}e^{-t/n}$  for  $n > 0$  and  $0 \leq t < \infty$ .

(a) Show that the maximum of  $f_n(t)$  is  $\frac{1}{n}$ .

(b) Show that  $f_n(t)$  converges uniformly to 0 as  $n \rightarrow \infty$ .

(c) Show that  $\int_0^\infty f_n(t) dt$  does not converge to 0 as  $n \rightarrow \infty$ .

(d) Why doesn't this contradict the theorem that “the integral of a uniform limit is the limit of the integrals”?

## Chapter 8

# Taylor and Laurent Series

*We think in generalities, but we live in details.*  
A. N. Whitehead

### 8.1 Power Series and Holomorphic Functions

We will see in this section that power series and holomorphic functions are intimately related. In fact, the two cornerstone theorems of this section are that any power series represents a holomorphic function, and conversely, any holomorphic function can be represented by a power series.

We begin by showing a power series represents a holomorphic function, and consider some of the consequences of this:

**Theorem 8.1.** *Suppose  $f(z) = \sum_{k \geq 0} c_k (z - z_0)^k$  has radius of convergence  $R$ . Then  $f$  is holomorphic in  $\{z \in \mathbb{C} : |z - z_0| < R\}$ .*

*Proof.* Given any closed curve  $\gamma \subset \{z \in \mathbb{C} : |z - z_0| < R\}$ , we have by Corollary 7.29

$$\int_{\gamma} \sum_{k \geq 0} c_k (z - z_0)^k dz = 0.$$

On the other hand, Corollary 7.28 says that  $f$  is continuous. Now apply Morera's theorem (Corollary 5.16).  $\square$

A special case of the last result concerns power series with infinite radius of convergence: those represent entire functions.

Now that we know that power series are holomorphic (i.e., differentiable) on their regions of convergence we can ask how to find their derivatives. The next result says that we can simply differentiate the series “term by term.”

**Theorem 8.2.** *Suppose  $f(z) = \sum_{k \geq 0} c_k (z - z_0)^k$  has radius of convergence  $R$ . Then*

$$f'(z) = \sum_{k \geq 1} k c_k (z - z_0)^{k-1},$$

*and the radius of convergence of this power series is also  $R$ .*

*Proof.* Let  $f(z) = \sum_{k \geq 0} c_k (z - z_0)^k$ . Since we know that  $f$  is holomorphic in its region of convergence we can use Theorem 5.1. Let  $\gamma$  be any simple closed curve in  $\{z \in \mathbb{C} : |z - z_0| < R\}$ . Note that the power series of  $f$  converges uniformly on  $\gamma$ , so that we are free to interchange integral and infinite sum. And then we use Theorem 5.1 *again*, but applied to the function  $(z - z_0)^k$ . Here are the details:

$$\begin{aligned} f'(z) &= \frac{1}{2\pi i} \int_{\gamma} \frac{f(w)}{(w - z)^2} dw \\ &= \frac{1}{2\pi i} \int_{\gamma} \frac{\sum_{k \geq 0} c_k (w - z_0)^k}{(w - z)^2} dw \\ &= \sum_{k \geq 0} c_k \cdot \frac{1}{2\pi i} \int_{\gamma} \frac{(w - z_0)^k}{(w - z)^2} dw \\ &= \sum_{k \geq 0} c_k \cdot \left. \frac{d}{dw} (w - z_0)^k \right|_{w=z} \\ &= \sum_{k \geq 0} k c_k (z - z_0)^{k-1}. \end{aligned}$$

The last statement of the theorem is easy to show: the radius of convergence  $R$  of  $f'(z)$  is at least  $R$  (since we have shown that the series converges whenever  $|z - z_0| < R$ ), and it cannot be larger than  $R$  by comparison to the series for  $f(z)$ , since the coefficients for  $(z - z_0)f'(z)$  are bigger than the corresponding ones for  $f(z)$ .  $\square$

Naturally, the last theorem can be repeatedly applied to  $f'$ , then to  $f''$ , and so on. The various derivatives of a power series can also be seen as ingredients of the series itself. This is the statement of the following *Taylor<sup>1</sup> series expansion*.

**Corollary 8.3.** *Suppose  $f(z) = \sum_{k \geq 0} c_k (z - z_0)^k$  has a positive radius of convergence. Then*

$$c_k = \frac{f^{(k)}(z_0)}{k!}.$$

*Proof.* For starters,  $f(z_0) = c_0$ . Theorem 8.2 gives  $f'(z_0) = c_1$ . Applying the same theorem to  $f'$  gives

$$f''(z) = \sum_{k \geq 2} k(k-1)c_k (z - z_0)^{k-2}$$

and  $f''(z_0) = 2c_2$ . We can play the same game for  $f'''(z_0)$ ,  $f''''(z_0)$ , etc.  $\square$

Taylor's formulas show that the coefficients of any power series which converges to  $f$  on an open disk  $D$  centered at  $z_0$  can be determined from the the function  $f$  restricted to  $D$ . It follows immediately that the coefficients of a power series are unique:

**Corollary 8.4** (Uniqueness of power series). *If  $\sum_{k \geq 0} c_k (z - z_0)^k$  and  $\sum_{k \geq 0} c'_k (z - z_0)^k$  are two power series which both converge to the same function  $f(z)$  on an open disk centered at a then  $c_k = c'_k$  for all  $k$ .*

---

<sup>1</sup>For more information about Brook Taylor (1685–1731), see <http://www-groups.dcs.st-and.ac.uk/~history/Biographies/Taylor.html>.

We now turn to the second cornerstone result, that a holomorphic function can be represented by a power series, and its implications.

**Theorem 8.5.** *Suppose  $f$  is a function which is holomorphic in  $D = \{z \in \mathbb{C} : |z - z_0| < R\}$ . Then  $f$  can be represented in  $D$  as a power series centered at  $z_0$  (with a radius of convergence at least  $R$ ):*

$$f(z) = \sum_{k \geq 0} c_k (z - z_0)^k \quad \text{with} \quad c_k = \frac{1}{2\pi i} \int_{\gamma} \frac{f(w)}{(w - z_0)^{k+1}} dw.$$

Here  $\gamma$  is any positively oriented, simple, closed, smooth curve in  $D$  for which  $z_0$  is inside  $\gamma$ .

*Proof.* Let  $g(z) = f(z + z_0)$ ; so  $g$  is a function holomorphic in  $\{z \in \mathbb{C} : |z| < R\}$ . Fix  $r < R$ , denote the circle centered at the origin with radius  $r$  by  $\gamma_r$ , and suppose that  $|z| < r$ . Then by Cauchy's integral formula (Theorem 4.10),

$$g(z) = \frac{1}{2\pi i} \int_{\gamma_r} \frac{g(w)}{w - z} dw.$$

The factor  $1/(w - z)$  in this integral can be extended into a geometric series (note that  $w \in \gamma_r$  and so  $|\frac{z}{w}| < 1$ )

$$\frac{1}{w - z} = \frac{1}{w} \frac{1}{1 - \frac{z}{w}} = \frac{1}{w} \sum_{k \geq 0} \left(\frac{z}{w}\right)^k$$

which converges uniformly in the variable  $w \in \gamma_r$  (by Lemma 7.26). Hence Proposition 7.20 applies:

$$g(z) = \frac{1}{2\pi i} \int_{\gamma_r} \frac{g(w)}{w - z} dw = \frac{1}{2\pi i} \int_{\gamma_r} g(w) \frac{1}{w} \sum_{k \geq 0} \left(\frac{z}{w}\right)^k dw = \sum_{k \geq 0} \frac{1}{2\pi i} \int_{\gamma_r} \frac{g(w)}{w^{k+1}} dw z^k.$$

Now, since  $f(z) = g(z - z_0)$ , we apply an easy change of variables to obtain

$$f(z) = \sum_{k \geq 0} \frac{1}{2\pi i} \int_{\Gamma_r} \frac{f(w)}{(w - z_0)^{k+1}} dw (z - z_0)^k,$$

where  $\Gamma_r$  is a circle centered at  $z_0$  with radius  $r$ . The only difference of this right-hand side to the statement of the theorem are the curves we're integrating over. However,  $\Gamma_r \sim_{G \setminus \{z_0\}} \gamma$ , and we can apply Cauchy's Theorem 4.6:

$$\int_{\Gamma_r} \frac{f(w)}{(w - z_0)^{k+1}} dw = \int_{\gamma} \frac{f(w)}{(w - z_0)^{k+1}} dw. \quad \square$$

If we compare the coefficients of the power series obtained in Theorem 8.5 with those in Corollary 8.3, we arrive at the long-promised extension of Theorem 5.1 (which in itself extended Cauchy's integral formula, Theorem 4.10).

**Corollary 8.6.** *Suppose  $f$  is holomorphic on the region  $G$ ,  $w \in G$ , and  $\gamma$  is a positively oriented, simple, closed, smooth,  $G$ -contractible curve such that  $w$  is inside  $\gamma$ . Then*

$$f^{(k)}(w) = \frac{k!}{2\pi i} \int_{\gamma} \frac{f(z)}{(z - w)^{k+1}} dz.$$

Corollary 8.6 combined with our often-used Proposition 4.4(d) gives an inequality which is often called *Cauchy's Estimate*:

**Corollary 8.7.** *Suppose  $f$  is holomorphic in  $\{z \in \mathbb{C} : |z - w| < R\}$  and  $|f| \leq M$ . Then*

$$\left| f^{(k)}(w) \right| \leq \frac{k!M}{R^k}.$$

*Proof.* Let  $\gamma$  be a circle centered at  $w$  with radius  $r < R$ . Then Corollary 8.6 applies, and we can estimate using Proposition 4.4(d):

$$\left| f^{(k)}(w) \right| = \left| \frac{k!}{2\pi i} \int_{\gamma} \frac{f(z)}{(z-w)^{k+1}} dz \right| \leq \frac{k!}{2\pi} \max_{z \in \gamma} \left| \frac{f(z)}{(z-w)^{k+1}} \right| \text{length}(\gamma) \leq \frac{k!}{2\pi} \frac{M}{r^{k+1}} 2\pi r = \frac{k!M}{r^k}.$$

The statement now follows since  $r$  can be chosen arbitrarily close to  $R$ .  $\square$

## 8.2 Classification of Zeros and the Identity Principle

Basic algebra shows that if a polynomial  $p(z)$  of positive degree  $d$  has a zero at  $a$  (in other words, if  $p(a) = 0$ ) then  $p(z)$  has  $z - a$  as a factor. That is,  $p(z) = (z - a)q(z)$  where  $q(z)$  is a polynomial of degree  $d - 1$ . We can then ask whether  $q(z)$  itself has a zero at  $a$  and, if so, we can factor out another factor of  $z - a$ . Continuing in this way we see that we can factor  $p(z)$  as  $p(z) = (z - a)^m g(z)$  where  $m$  is a positive integer, not bigger than  $d$ , and  $g(z)$  is a polynomial which does not have a zero at  $a$ . The integer  $m$  is called the *multiplicity* of the zero  $a$  of  $p(z)$ .

Almost exactly the same thing happens for holomorphic functions:

**Theorem 8.8** (Classification of Zeros). *Suppose  $f$  is an holomorphic function defined on an open set  $G$  and suppose  $f$  has a zero at a point  $a$  in  $G$ . Then there are exactly two possibilities:*

- (a) *Either:  $f$  is identically zero on some open disk  $D$  centered at  $a$  (that is,  $f(z) = 0$  for all  $z$  in  $D$ );*
- (b) *or: there is a positive integer  $m$  and a holomorphic function  $g$ , defined on  $G$ , satisfying  $f(z) = (z - a)^m g(z)$  for all  $z$  in  $G$ , with  $g(a) \neq 0$*

*The integer  $m$  in the second case is uniquely determined by  $f$  and  $a$  and is called the multiplicity of the zero at  $a$ .*

*Proof.* We have a power series expansion for  $f(z)$  in some disk  $D_r(a)$  of radius  $r$  around  $a$ , so  $f(z) = \sum_{k \geq 0} c_k (z - a)^k$ , and  $c_0 = f(a)$  is zero since  $a$  is a zero of  $f$ . There are now exactly two possibilities:

- (a) Either  $c_k = 0$  for all  $k$ ;
- (b) or there is some positive integer  $m$  so that  $c_k = 0$  for all  $k < m$  but  $c_m \neq 0$ .

The first case clearly gives us  $f(z) = 0$  for all  $z$  in  $D = D_r(a)$ . So now consider the second case. Notice that

$$\begin{aligned} f(z) &= c_m (z - a)^m + c_{m+1} (z - a)^{m+1} + \cdots = (z - a)^m (c_m + c_{m+1} (z - a) + \cdots) \\ &= (z - a)^m \sum_{k \geq 0} c_{k+m} (z - a)^k. \end{aligned}$$

Then we can define a function  $g$  on  $G$  by

$$g(z) = \begin{cases} \sum_{k \geq 0} c_{k+m}(z-a)^k & \text{if } |z-a| < r \\ \frac{f(z)}{(z-a)^m} & \text{if } z \in G \setminus \{a\} \end{cases}$$

According to our calculations above, the two definitions give the same value when both are applicable. The function  $g$  is holomorphic at  $a$  by the first definition; and  $g$  is holomorphic at other points of  $G$  by the second definition. Finally,  $g(a) = c_m \neq 0$ .

Clearly  $m$  is unique, since it is defined in terms of the power series expansion of  $f$  at  $a$ , which is unique.  $\square$

To start using the intimate connection of holomorphic functions and power series, we apply Theorem 8.8 to obtain the following result, which is sometimes also called the *uniqueness theorem*.

**Theorem 8.9** (Identity Principle). *Suppose  $f$  and  $g$  are holomorphic in the region  $G$  and  $f(z_k) = g(z_k)$  at a sequence which converges to  $w \in G$  with  $z_k \neq w$  for all  $k$ . Then  $f(z) = g(z)$  for all  $z$  in  $G$ .*

*Proof.* We start by defining  $h = f - g$ . Then  $h$  is holomorphic on  $G$ ,  $h(z_k) = 0$ , and we will be finished if we can deduce that  $h$  is identically zero on  $G$ . Now notice the following: If  $b$  is in  $G$  then exactly one of the following occurs:

- (a) Either there is an open disk  $D$  centered at  $b$  so that  $h(z) = 0$  for all  $z$  in  $D$ ;
- (b) or there is an open disk  $D$  centered at  $b$  so that  $h(z) \neq 0$  for all  $z$  in  $D \setminus \{b\}$ .

To see this, suppose that  $h(b) \neq 0$ . Then, by continuity, there is an open disk  $D$  centered at  $b$  so that  $h(z) \neq 0$  for all  $z \in D$ , so  $b$  satisfies the second condition. If  $h(b) = 0$  then, by the classification of zeros, either  $h(z) = 0$  for all  $z$  in some open disk  $D$  centered at  $b$ , so  $b$  satisfies the first condition; or  $h(z) = (z-b)^m \phi(z)$  for all  $z$  in  $G$ , where  $\phi$  is holomorphic and  $\phi(b) \neq 0$ . Then, since  $\phi$  is continuous, there is an open disk  $D$  centered at  $b$  so that  $\phi(z) \neq 0$  for all  $z$  in  $D$ . Then  $h(z) = (z-b)^m \phi(z) \neq 0$  for all  $z$  in  $D$  except  $z = b$ , so  $b$  satisfies the second condition.

Now define two sets  $X, Y \subseteq G$ , so that  $b \in X$  if  $b$  satisfies the first condition above, and  $b \in Y$  if  $b$  satisfies the second condition. If  $b \in X$  and  $D$  is an open disk centered at  $b$  as in the first condition then it is clear that  $D \subseteq X$ . If  $b \in Y$  and  $D$  is an open disk centered at  $b$  as in the second condition then  $D \subseteq Y$ , since if  $z \in D \setminus \{b\}$  then  $h(z) \neq 0$ , and we saw that this means  $z$  satisfies the second condition.

Finally, we check that our original point  $w$  lies in  $X$ . To see this, suppose  $w \in Y$ , and let  $D$  be an open disk centered at  $w$  so that  $h(z) \neq 0$  for all  $z$  in  $D$  except  $z = w$ . But, since the sequence  $z_k$  converges to  $w$ , there is some  $k$  so that  $z_k$  is in  $D$ , so  $h(z_k) = 0$ . Since  $z_k \neq w$ , this is a contradiction.

Now we finish the proof using the definition of connectedness.  $X$  and  $Y$  are disjoint open sets whose union is  $G$ , so one of them must be empty. Since  $a$  is in  $X$ , we must have  $Y = \emptyset$  and  $X = G$ . But  $X = G$  implies that every  $z$  in  $G$  satisfies the first condition above, so  $h(z) = 0$ .  $\square$

Using the identity principle, we can prove yet another important property of holomorphic functions.

**Theorem 8.10** (Maximum-Modulus Theorem). *Suppose  $f$  is holomorphic and not constant in the region  $G$ . Then  $|f|$  does not attain a weak relative maximum in  $G$ .*

There are many reformulations of this theorem, such as: If  $G$  is a bounded region and  $f$  is holomorphic in the closure of  $G$ , then the maximum of  $|f|$  is attained on the boundary of  $G$ .

*Proof.* Suppose there is a point  $a$  in  $G$  and an open disk  $D_0$  centered at  $a$  so that  $|f(a)| \geq |f(z)|$  for all  $z$  in  $D_0$ . If  $f(a) = 0$  then  $f(z) = 0$  for all  $z$  in  $D_0$ , so  $f$  is identically zero, by the identity principle. So we assume  $f(a) \neq 0$ . In this case we can define an holomorphic function  $g(z) = f(z)/f(a)$ , and we have the condition  $|g(z)| \leq |g(a)| = 1$  for all  $z$  in  $D_0$ . Since  $g(a) = 1$  we can find, using continuity, a smaller open disk  $D$  centered at  $a$  so that  $g(z)$  has positive real part for all  $z$  in  $D$ . Thus the function  $h = \text{Log} \circ g$  is defined and holomorphic on  $D$ , and we have  $h(a) = \text{Log}(g(a)) = \text{Log}(1) = 0$  and  $\text{Re } h(z) = \text{Re } \text{Log}(g(z)) = \ln(|g(z)|) \leq \ln(1) = 0$ .

We now refer to Exercise 27, which shows that  $h$  must be identically zero in  $D$ . Hence  $g(z) = e^{h(z)}$  must be equal to  $e^0 = 1$  for all  $z$  in  $D$ , and so  $f(z) = f(a)g(z)$  must have the constant value  $f(a)$  for all  $z$  in  $D$ . Hence, by the identity principle,  $f(z)$  has the constant value  $f(a)$  for all  $z$  in  $G$ .  $\square$

Theorem 8.10 can be used to give a proof of the analogous theorem for harmonic functions, Theorem 6.6, in the process strengthening that theorem to cover weak maxima and weak minima.

**Corollary 8.11.** *If  $u$  is harmonic in the region  $G$ , then it does not have a weak relative maximum or minimum in  $G$ .*

Since the last corollary also covers minima of harmonic functions, we should not be too surprised to find the following result whose proof we leave for the exercises.

**Corollary 8.12** (Minimum-Modulus Theorem). *Suppose  $f$  is holomorphic and not constant in the region  $G$ . Then  $|f|$  does not attain a weak relative minimum at  $a$  in  $G$  unless  $f(a) = 0$ .*

### 8.3 Laurent Series

Theorem 8.5 gives a powerful way of describing holomorphic functions. It is, however, not as general as it could be. It is natural, for example, to think about representing  $\exp\left(\frac{1}{z}\right)$  as

$$\exp\left(\frac{1}{z}\right) = \sum_{k \geq 0} \frac{1}{k!} \left(\frac{1}{z}\right)^k = \sum_{k \geq 0} \frac{1}{k!} z^{-k},$$

a “power series” with negative exponents. To make sense of expressions like the above, we introduce the concept of a *double series*

$$\sum_{k \in \mathbb{Z}} a_k = \sum_{k \geq 0} a_k + \sum_{k \geq 1} a_{-k}.$$

Here  $a_k \in \mathbb{C}$  are terms indexed by the integers. A double series converges if and only if both of its defining series do. Absolute and uniform convergence are defined analogously. Equipped with this, we can now state the following central definition.

**Definition 8.13.** A Laurent<sup>2</sup> series centered at  $z_0$  is a double series of the form  $\sum_{k \in \mathbb{Z}} c_k (z - z_0)^k$ .

**Example 8.14.** The series which started this section is the Laurent series of  $\exp(\frac{1}{z})$  centered at 0.

**Example 8.15.** Any power series is a Laurent series (with  $c_k = 0$  for  $k < 0$ ).

We should pause for a minute and ask for which  $z$  such a Laurent series can possibly converge. By definition

$$\sum_{k \in \mathbb{Z}} c_k (z - z_0)^k = \sum_{k \geq 0} c_k (z - z_0)^k + \sum_{k \geq 1} c_{-k} (z - z_0)^{-k}.$$

The first of the series on the right-hand side is a power series with some radius of convergence  $R_2$ , that is, it converges in  $\{z \in \mathbb{C} : |z - z_0| < R_2\}$ . The second we can view as a “power series in  $\frac{1}{z - z_0}$ ,” it will converge for  $\frac{1}{|z - z_0|} < \frac{1}{R_1}$  for some  $R_1$ , that is, in  $\{z \in \mathbb{C} : |z - z_0| > R_1\}$ . For the convergence of our Laurent series, we need to combine those two notions, whence the Laurent series converges on the annulus  $\{z \in \mathbb{C} : R_1 < |z - z_0| < R_2\}$  (if  $R_1 < R_2$ ). Even better, Theorem 7.27 implies that the convergence is uniform on a set of the form  $\{z \in \mathbb{C} : r_1 \leq |z - z_0| \leq r_2\}$  for any  $R_1 < r_1 < r_2 < R_2$ . Theorem 8.1 says that the Laurent series represents a function which is holomorphic on  $\{z \in \mathbb{C} : R_1 < |z - z_0| < R_2\}$ . The fact that we can conversely represent any function holomorphic in such an annulus by a Laurent series is the substance of the next theorem.

**Theorem 8.16.** Suppose  $f$  is a function which is holomorphic in  $A = \{z \in \mathbb{C} : R_1 < |z - z_0| < R_2\}$ . Then  $f$  can be represented in  $A$  as a Laurent series centered at  $z_0$ :

$$f(z) = \sum_{k \in \mathbb{Z}} c_k (z - z_0)^k \quad \text{with} \quad c_k = \frac{1}{2\pi i} \int_{\gamma} \frac{f(w)}{(w - z_0)^{k+1}} dw.$$

Here  $\gamma$  is any circle in  $A$  centered at  $z_0$ .

*Remark.* Naturally, by Cauchy’s Theorem 4.6 we can replace the circle in the formula for the Laurent series by any closed, smooth path that is  $A$ -homotopic to the circle.

*Proof.* Let  $g(z) = f(z + z_0)$ ; so  $g$  is a function holomorphic in  $\{z \in \mathbb{C} : R_1 < |z| < R_2\}$ . Fix  $R_1 < r_1 < |z| < r_2 < R_2$ , and let  $\gamma_1$  and  $\gamma_2$  be positively oriented circles centered at 0 with radii  $r_1$  and  $r_2$ , respectively. By introducing an “extra piece” (see Figure 8.1), we can apply Cauchy’s integral formula (Theorem 4.10) to the path  $\gamma_2 - \gamma_1$ :

$$g(z) = \frac{1}{2\pi i} \int_{\gamma_2 - \gamma_1} \frac{g(w)}{w - z} dw = \frac{1}{2\pi i} \int_{\gamma_2} \frac{g(w)}{w - z} dw - \frac{1}{2\pi i} \int_{\gamma_1} \frac{g(w)}{w - z} dw. \quad (8.1)$$

For the integral over  $\gamma_2$  we play exactly the same game as in Theorem 8.5. The factor  $1/(w - z)$  in this integral can be expanded into a geometric series (note that  $w \in \gamma_2$  and so  $|\frac{z}{w}| < 1$ )

$$\frac{1}{w - z} = \frac{1}{w} \frac{1}{1 - \frac{z}{w}} = \frac{1}{w} \sum_{k \geq 0} \left(\frac{z}{w}\right)^k,$$

<sup>2</sup>For more information about Pierre Alphonse Laurent (1813–1854), see [http://www-groups.dcs.st-and.ac.uk/~history/Biographies/Laurent\\_Pierre.html](http://www-groups.dcs.st-and.ac.uk/~history/Biographies/Laurent_Pierre.html).



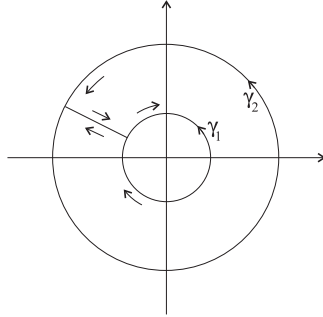

Figure 8.1: Proof of Theorem 8.16.

which converges uniformly in the variable  $w \in \gamma_2$  (by Lemma 7.26). Hence Proposition 7.20 applies:

$$\int_{\gamma_2} \frac{g(w)}{w-z} dw = \int_{\gamma_2} g(w) \frac{1}{w} \sum_{k \geq 0} \left(\frac{z}{w}\right)^k dw = \sum_{k \geq 0} \int_{\gamma_2} \frac{g(w)}{w^{k+1}} dw z^k.$$

The integral over  $\gamma_1$  is computed in a similar fashion; now we expand the factor  $1/(w-z)$  into the following geometric series (note that  $w \in \gamma_1$  and so  $|\frac{w}{z}| < 1$ )

$$\frac{1}{w-z} = -\frac{1}{z} \frac{1}{1-\frac{w}{z}} = -\frac{1}{z} \sum_{k \geq 0} \left(\frac{w}{z}\right)^k,$$

which converges uniformly in the variable  $w \in \gamma_1$  (by Lemma 7.26). Again Proposition 7.20 applies:

$$\int_{\gamma_1} \frac{g(w)}{w-z} dw = - \int_{\gamma_1} g(w) \frac{1}{z} \sum_{k \geq 0} \left(\frac{w}{z}\right)^k dw = - \sum_{k \geq 0} \int_{\gamma_1} g(w) w^k dw z^{-k-1} = - \sum_{k \leq -1} \int_{\gamma_1} \frac{g(w)}{w^{k+1}} dw z^k.$$

Putting everything back into (8.1) gives

$$g(z) = \frac{1}{2\pi i} \sum_{k \geq 0} \int_{\gamma_2} \frac{g(w)}{w^{k+1}} dw z^k + \sum_{k \leq -1} \int_{\gamma_1} \frac{g(w)}{w^{k+1}} dw z^k.$$

We can now change both integration paths to a circle  $\gamma$  centered at 0 with a radius between  $R_1$  and  $R_2$  (by Cauchy's Theorem 4.6), which finally gives

$$g(z) = \frac{1}{2\pi i} \sum_{k \in \mathbb{Z}} \int_{\gamma} \frac{g(w)}{w^{k+1}} dw z^k.$$

The statement follows now with  $f(z) = g(z - z_0)$  and an easy change of variables. □

We finish this chapter with a consequence of the above theorem: because the coefficients of a Laurent series are given by integrals, we immediately obtain the following:

**Corollary 8.17.** *For a given function in a given region of convergence, the coefficients of the corresponding Laurent series are uniquely determined.*

This result seems a bit artificial; what it says is simply the following: if we expand a function (that is holomorphic in some annulus) into a Laurent series, there is only one possible outcome.

## Exercises

1. For each of the following series, determine where the series converges absolutely/uniformly:

$$(a) \sum_{k \geq 2} k(k-1)z^{k-2}.$$

$$(b) \sum_{k \geq 0} \frac{1}{(2k+1)!} z^{2k+1}.$$

$$(c) \sum_{k \geq 0} \left( \frac{1}{z-3} \right)^k.$$

2. What functions are represented by the series in the previous exercise?
3. Find the power series centered at 1 for  $\exp z$ .
4. Prove Lemma 3.16 using the power series of  $\exp z$  centered at 0.
5. By integrating a series for  $\frac{1}{1+z^2}$  term by term, find a power series for  $\arctan(z)$ . What is its radius of convergence?
6. Find the terms through third order and the radius of convergence of the power series for each following functions, centered at  $z_0$ . *Do not find the general form for the coefficients.*

$$(a) f(z) = \frac{1}{1+z^2}, \quad z_0 = 1.$$

$$(b) f(z) = \frac{1}{e^z+1}, \quad z_0 = 0.$$

$$(c) f(z) = \sqrt{1+z}, \quad z_0 = 0 \text{ (use the principal branch).}$$

$$(d) f(z) = e^{z^2}, \quad z_0 = i.$$

7. Prove the following generalization of Theorem 8.1: Suppose  $f_n$  are holomorphic on the region  $G$  and converge uniformly to  $f$  on  $G$ . Then  $f$  is holomorphic in  $G$ . (This result is called the *Weierstraß convergence theorem*.)
8. Use the previous exercise and Corollary 8.7 to prove the following: Suppose  $f_n$  are holomorphic on the region  $G$  and converge uniformly to  $f$  on  $G$ . Then for any  $k \in \mathbb{N}$ , the  $k^{\text{th}}$  derivatives  $f_n^{(k)}$  converge (pointwise) to  $f^{(k)}$ .
9. Prove the minimum-modulus theorem (Corollary 8.12).

10. Find the maximum and minimum of  $|f(z)|$  on the unit disc  $\{z \in \mathbb{C} : |z| \leq 1\}$ , where  $f(z) = z^2 - 2$ .
11. Give another proof of the fundamental theorem of algebra (Theorem 5.7), using the minimum-modulus theorem (Corollary 8.12). (*Hint*: Use Lemma 5.6 to show that a polynomial does not achieve its minimum modulus on a large circle; then use the minimum-modulus theorem to deduce that the polynomial has a zero.)
12. Find a Laurent series for  $\frac{1}{(z-1)(z+1)}$  centered at  $z = 1$  and specify the region in which it converges.
13. Find a Laurent series for  $\frac{1}{z(z-2)^2}$  centered at  $z = 2$  and specify the region in which it converges.
14. Find a Laurent series for  $\frac{z-2}{z+1}$  centered at  $z = -1$  and specify the region in which it converges.
15. Find the first five terms in the Laurent series for  $\frac{1}{\sin z}$  centered at  $z = 0$ .
16. Find the first 4 non-zero terms in the power series expansion of  $\tan z$  centered at the origin. What is the radius of convergence?
17. (a) Find the power series representation for  $e^{az}$  centered at 0, where  $a$  is any constant.  
 (b) Show that  $e^z \cos(z) = \frac{1}{2} (e^{(1+i)z} + e^{(1-i)z})$ .  
 (c) Find the power series expansion for  $e^z \cos(z)$  centered at 0.
18. Show that  $\frac{z-1}{z-2} = \sum_{k \geq 0} \frac{1}{(z-1)^k}$  for  $|z-1| > 1$ .
19. Prove: If  $f$  is entire and  $\text{Im}(f)$  is constant on the unit disc  $\{z \in \mathbb{C} : |z| \leq 1\}$  then  $f$  is constant.
20. (a) Find the Laurent series for  $\frac{\cos z}{z^2}$  centered at  $z = 0$ .  
 (b) Prove that
- $$f(z) = \begin{cases} \frac{\cos z - 1}{z^2} & \text{if } z \neq 0, \\ -\frac{1}{2} & \text{if } z = 0 \end{cases}$$
- is entire.
21. Find the Laurent series for  $\sec z$  centered at the origin.
22. Suppose that  $f$  is holomorphic,  $f(z_0) = 0$ , and  $f'(z_0) \neq 0$ . Show that  $f$  has a zero of multiplicity 1 at  $z_0$ .
23. Find the multiplicities of the zeros:
- (a)  $f(z) = e^z - 1$ ,  $z_0 = 2k\pi i$ , where  $k$  is any integer.  
 (b)  $f(z) = \sin(z) - \tan(z)$ ,  $z_0 = 0$ .  
 (c)  $f(z) = \cos(z) - 1 + \frac{1}{2} \sin^2(z)$ ,  $z_0 = 0$ .
24. Find the zeros of the following, and determine their multiplicities:
- (a)  $(1 + z^2)^4$ .

- (b)  $\sin^2 z$ .
- (c)  $1 + e^z$ .
- (d)  $z^3 \cos z$ .
25. Find the three Laurent series of  $f(z) = \frac{1}{(1-z)(z+2)}$ , centered at 0, but which are defined on the three domains  $|z| < 1$ ,  $1 < |z| < 2$ , and  $2 < |z|$ , respectively. *Hint: Use Theorem 8.16.*
26. Suppose that  $f(z)$  has exactly one zero, at  $a$ , inside the circle  $\gamma$ , and that it has multiplicity 1. Show that  $a = \frac{1}{2\pi i} \int_{\gamma} \frac{zf'(z)}{f(z)} dz$ .
27. Suppose  $f$  is holomorphic and not identically zero on an open disk  $D$  centered at  $a$ , and suppose  $f(a) = 0$ . Follow the following outline to show that  $\operatorname{Re} f(z) > 0$  for some  $z$  in  $D$ .
- (a) Why can you write  $f(z) = (z - a)^m g(z)$  where  $m > 0$ ,  $g$  is holomorphic, and  $g(a) \neq 0$ ?
- (b) Write  $g(a)$  in polar form as  $g(a) = c e^{i\alpha}$  and define  $G(z) = e^{-i\alpha} g(z)$ . Why is  $\operatorname{Re} G(a) > 0$ ?
- (c) Why is there a positive constant  $\delta$  so that  $\operatorname{Re} G(z) > 0$  for all  $z$  in the open disk  $D_{\delta}(a)$ ?
- (d) Write  $z = a + r e^{i\theta}$  for  $0 < r < \delta$ . Show that  $f(z) = r^m e^{im\theta} e^{i\alpha} G(z)$ .
- (e) Find a value of  $\theta$  so that  $f(z)$  has positive real part.
28. Suppose  $|c_n| \geq 2^n$  for all  $n$ . What can you say about the radius of convergence of  $\sum_{k \geq 0} c_k z^k$ ?
29. Suppose the radius of convergence of  $\sum_{k \geq 0} c_k z^k$  is  $R$ . What is the radius of convergence of each of the following?
- (a)  $\sum_{k \geq 0} c_k z^{2k}$ .
- (b)  $\sum_{k \geq 0} 3^k c_k z^k$ .
- (c)  $\sum_{k \geq 0} c_k z^{k+5}$ .
- (d)  $\sum_{k \geq 0} k^2 c_k z^k$ .
- (e)  $\sum_{k \geq 0} c_k^2 z^k$ . (*Hint: Ratio test*)

## Chapter 9

# Isolated Singularities and the Residue Theorem

*1/r<sup>2</sup> has a nasty singularity at r = 0, but it did not bother Newton—the moon is far enough.*  
Edward Witten

### 9.1 Classification of Singularities

What is the difference between the functions  $\frac{\sin z}{z}$ ,  $\frac{1}{z^4}$ , and  $\exp\left(\frac{1}{z}\right)$ ? All of them are not defined at 0, but the singularities are of a very different nature. For complex functions there are three types of singularities, which are classified as follows.

**Definition 9.1.** If  $f$  is holomorphic in the punctured disk  $\{z \in \mathbb{C} : 0 < |z - z_0| < R\}$  for some  $R > 0$  but not at  $z = z_0$  then  $z_0$  is an *isolated singularity* of  $f$ . The singularity  $z_0$  is called

- (a) *removable* if there is a function  $g$  holomorphic in  $\{z \in \mathbb{C} : |z - z_0| < R\}$  such that  $f = g$  in  $\{z \in \mathbb{C} : 0 < |z - z_0| < R\}$ ,
- (b) a *pole* if  $\lim_{z \rightarrow z_0} |f(z)| = \infty$ ,
- (c) *essential* if  $z_0$  is neither removable nor a pole.

**Example 9.2.** The function  $\frac{\sin z}{z}$  has a removable singularity at 0, as for  $z \neq 0$

$$\frac{\sin z}{z} = \frac{1}{z} \sum_{k \geq 0} \frac{(-1)^k}{(2k+1)!} z^{2k+1} = \sum_{k \geq 0} \frac{(-1)^k}{(2k+1)!} z^{2k}.$$

and the power series on the right-hand side represents an entire function (you may meditate on the fact why it has to be entire).

**Example 9.3.** The function  $\frac{1}{z^4}$  has a pole at 0, as

$$\lim_{z \rightarrow 0} \left| \frac{1}{z^4} \right| = \infty.$$

**Example 9.4.** The function  $\exp\left(\frac{1}{z}\right)$  does not have a removable singularity (consider, for example,  $\lim_{x \rightarrow 0^+} \exp\left(\frac{1}{x}\right) = \infty$ ). On the other hand,  $\exp\left(\frac{1}{z}\right)$  approaches 0 as  $z$  approaches 0 from the negative real axis. Hence  $\lim_{z \rightarrow 0} \left|\exp\left(\frac{1}{z}\right)\right| \neq \infty$ , that is,  $\exp\left(\frac{1}{z}\right)$  has an essential singularity at 0.

To get a feel for the different types of singularities, we start with the following results.

**Proposition 9.5.** *Suppose  $z_0$  is a isolated singularity of  $f$ . Then*

- (a)  $z_0$  is removable if and only if  $\lim_{z \rightarrow z_0} (z - z_0) f(z) = 0$ ;
- (b) if  $z_0$  is a pole then  $\lim_{z \rightarrow z_0} (z - z_0)^{n+1} f(z) = 0$  for some positive integer  $n$ .

*Remark.* The smallest possible  $n$  in (b) is the *order* of the pole. We will see in the proof that “near the pole  $z_0$ ” we can write  $f(z)$  as  $\frac{h(z)}{(z - z_0)^n}$  for some function  $h$  which is holomorphic (and not zero) at  $z_0$ . This is very similar to the game we played with zeros in Chapter 8:  $f$  has a zero of order (or multiplicity)  $m$  at  $z_0$  if we can write  $f(z) = (z - z_0)^m h(z)$ , where  $h$  is holomorphic and not zero at  $z_0$ . We will make use of the notions of zeros and poles of certain orders quite extensively in this chapter.

*Proof.* (a) Suppose  $z_0$  is removable, and  $g$  is holomorphic on  $D_R(z_0)$ , the open disk with radius  $R$  centered at  $z_0$  such that  $f = g$  for  $z \neq z_0$ . Then we can make use of the fact that  $g$  is continuous at  $z_0$ :

$$\lim_{z \rightarrow z_0} (z - z_0) f(z) = \lim_{z \rightarrow z_0} (z - z_0) g(z) = g(z_0) \lim_{z \rightarrow z_0} (z - z_0) = 0.$$

Conversely, suppose that  $\lim_{z \rightarrow z_0} (z - z_0) f(z) = 0$ , and  $f$  is holomorphic on the punctured disk  $\hat{D}_R(z_0) = D_R(z_0) \setminus \{z_0\}$ . Then define

$$g(z) = \begin{cases} (z - z_0)^2 f(z) & \text{if } z \neq z_0, \\ 0 & \text{if } z = z_0. \end{cases}$$

Clearly  $g$  is holomorphic for  $z \neq z_0$ , and it is also differentiable at  $z_0$ , since we can calculate

$$g'(z_0) = \lim_{z \rightarrow z_0} \frac{g(z) - g(z_0)}{z - z_0} = \lim_{z \rightarrow z_0} \frac{(z - z_0)^2 f(z)}{z - z_0} = \lim_{z \rightarrow z_0} (z - z_0) f(z) = 0$$

So  $g$  is holomorphic in  $D_R(z_0)$  with  $g(z_0) = 0$  and  $g'(z_0) = 0$ , so it has a power series expansion  $g(z) = \sum_{k \geq 0} c_k (z - z_0)^k$  with  $c_0 = c_1 = 0$ . Hence we can factor  $(z - z_0)^2$  from the series, so

$$g(z) = (z - z_0)^2 \sum_{k \geq 0} c_{k+2} (z - z_0)^k = (z - z_0)^2 f(z).$$

Hence, for  $z \neq z_0$ ,  $f(z) = \sum_{k \geq 0} c_{k+2} (z - z_0)^k$ , and this series defines an holomorphic function in  $D_R(z_0)$ .

(b) Suppose that  $z_0$  is a pole of  $f$ . Then there is some  $R > 0$  so that  $|f(z)| > 1$  in the punctured disk  $\hat{D}_R(z_0)$ , and

$$\lim_{z \rightarrow z_0} \frac{1}{f(z)} = 0.$$

So, if we define  $g(z)$  by

$$g(z) = \begin{cases} \frac{1}{f(z)} & \text{if } z \in \hat{D}_R(z_0), \\ 0 & \text{if } z = z_0, \end{cases}$$

then  $g$  is holomorphic in  $D_R(z_0)$  (as in part (a)). By the classification of zeros,  $g(z) = (z - z_0)^n \phi(z)$  where  $\phi$  is holomorphic in  $D_R(z_0)$  and  $\phi(z_0) \neq 0$ . In fact,  $\phi(z) \neq 0$  for all  $z$  in  $D_R(z_0)$  since  $g(z) \neq 0$  for  $z \in \hat{D}_R(z_0)$ . Hence  $h = \frac{1}{\phi}$  is an holomorphic function in  $D_R(z_0)$  and

$$f(z) = \frac{1}{g(z)} = \frac{1}{(z - z_0)^n \phi(z)} = \frac{h(z)}{(z - z_0)^n}.$$

But then, since  $h$  is continuous at  $z_0$ ,

$$\lim_{z \rightarrow z_0} (z - z_0)^{n+1} f(z) = \lim_{z \rightarrow z_0} (z - z_0) h(z) = h(z_0) \lim_{z \rightarrow z_0} (z - z_0) = 0. \quad \square$$

The reader might have noticed that the previous proposition did not include any result on essential singularities. Not only does the next theorem make up for this but it also nicely illustrates the strangeness of essential singularities. To appreciate the following result, we suggest meditating about its statement for a couple of minutes over a good cup of coffee.

**Theorem 9.6** (Casorati<sup>1</sup>-Weierstraß). *If  $z_0$  is an essential singularity of  $f$  and  $D = \{z \in \mathbb{C} : 0 < |z - z_0| < R\}$  for some  $R > 0$ , then any  $w \in \mathbb{C}$  is arbitrarily close to a point in  $f(D)$ , that is, for any  $w \in \mathbb{C}$  and any  $\epsilon > 0$  there exists  $z \in D$  such that  $|w - f(z)| < \epsilon$ .*

*Remarks.* 1. In the language of topology, the Casorati-Weierstraß theorem says that the image of any punctured disc centered at an essential singularity is *dense* in  $\mathbb{C}$ .

2. There is a much stronger theorem, which is beyond the scope of this book, and which implies the Casorati-Weierstraß theorem. It is due to Charles Emile Picard (1856–1941)<sup>2</sup> and says that the image of any punctured disc centered at an essential singularity misses at most one point of  $\mathbb{C}$ . (It is worth meditating about coming up with examples of functions which do not miss any point in  $\mathbb{C}$  and functions which miss exactly one point. Try it!)

*Proof.* Suppose (by way of contradiction) that there is a  $w \in \mathbb{C}$  and an  $\epsilon > 0$  such that for all  $z$  in the punctured disc  $D$  (centered at  $z_0$ )

$$|w - f(z)| \geq \epsilon.$$

Then the function  $g(z) = \frac{1}{(f(z) - w)}$  stays bounded as  $z \rightarrow z_0$ , and so

$$\lim_{z \rightarrow z_0} (z - z_0)g(z) = \lim_{z \rightarrow z_0} \frac{z - z_0}{f(z) - w} = 0.$$

(The previous proposition tells us that  $g$  has a removable singularity at  $z_0$ .) Hence

$$\lim_{z \rightarrow z_0} \left| \frac{f(z) - w}{z - z_0} \right| = \infty.$$

But this implies that  $f$  has a pole or a removable singularity at  $z_0$ , which is a contradiction.  $\square$

<sup>1</sup>For more information about Felice Casorati (1835–1890), see <http://www-groups.dcs.st-and.ac.uk/~history/Biographies/Casorati.html>.

<sup>2</sup>For more information about Picard, see [http://www-groups.dcs.st-and.ac.uk/~history/Biographies/Picard\\_Emile.html](http://www-groups.dcs.st-and.ac.uk/~history/Biographies/Picard_Emile.html).

Definition 9.1 is not always handy. The following classifies singularities according to their Laurent series.

**Proposition 9.7.** *Suppose  $z_0$  is an isolated singularity of  $f$  with Laurent series*

$$f(z) = \sum_{k \in \mathbb{Z}} c_k (z - z_0)^k$$

(valid in  $\{z \in \mathbb{C} : 0 < |z - z_0| < R\}$  for some  $R > 0$ ). Then

- (a)  $z_0$  is removable if and only if there are no negative exponents (that is, the Laurent series is a power series);
- (b)  $z_0$  is a pole if and only if there are finitely many negative exponents;
- (c)  $z_0$  is essential if and only if there are infinitely many negative exponents.

*Proof.* (a) Suppose  $z_0$  is removable, and  $g$  is holomorphic on  $\{z \in \mathbb{C} : |z - z_0| < R\}$  such that  $f = g$  in  $\{z \in \mathbb{C} : 0 < |z - z_0| < R\}$ . Then the Laurent series of  $g$  in this region is a power series, and by Corollary 8.17 (uniqueness theorem for Laurent series) it has to coincide with the Laurent series of  $f$ . Conversely, if the Laurent series of  $f$  at  $z_0$  has only nonnegative powers, we can use it to define a function which is holomorphic at  $z_0$ .

(b) Suppose  $z_0$  is a pole of order  $n$ . Then by Proposition 9.5, the function  $(z - z_0)^n f(z)$  has a removable singularity at  $z_0$ . By part (a), we can hence expand

$$(z - z_0)^n f(z) = \sum_{k \geq 0} c_k (z - z_0)^k,$$

that is,

$$f(z) = \sum_{k \geq 0} c_k (z - z_0)^{k-n} = \sum_{k \geq -n} c_k (z - z_0)^k.$$

Conversely, suppose that

$$f(z) = \sum_{k \geq -n} c_k (z - z_0)^k = (z - z_0)^{-n} \sum_{k \geq -n} c_k (z - z_0)^{k+n} = (z - z_0)^{-n} \sum_{k \geq 0} c_{k-n} (z - z_0)^k,$$

where  $c_{-n} \neq 0$ . Define

$$g(z) = \sum_{k \geq 0} c_{k-n} (z - z_0)^k.$$

Then since  $g(z_0) = c_{-n} \neq 0$ ,

$$\lim_{z \rightarrow z_0} |f(z)| = \lim_{z \rightarrow z_0} \left| \frac{g(z)}{(z - z_0)^n} \right| = \infty.$$

(c) This follows by definition: an essential singularity is neither removable nor a pole.  $\square$



## 9.2 Residues

Suppose  $z_0$  is an isolated singularity of  $f$ ,  $\gamma$  is a positively oriented, simple, closed, smooth path around  $z_0$ , which lies in the domain of the Laurent series of  $f$  at  $z_0$  with domain a punctured disk  $\{z \mid 0 < |z - z_0| < R\}$  for some radius  $R > 0$ . Then—essentially by Proposition 7.20—we can integrate term by term:

$$\int_{\gamma} f = \int_{\gamma} \sum_{k \in \mathbb{Z}} c_k (z - z_0)^k dz = \sum_{k \in \mathbb{Z}} c_k \int_{\gamma} (z - z_0)^k dz.$$

The integrals inside the summation are easy: for nonnegative powers  $k$  the integral  $\int_{\gamma} (z - z_0)^k$  is 0 (because  $(z - z_0)^k$  is entire), and the same holds for  $k \leq -2$  (because  $(z - z_0)^k$  has a primitive on  $\mathbb{C} \setminus \{z_0\}$ , or alternatively because applying the change of variables  $w = \frac{1}{z - z_0}$  yields the integral  $\int_{\gamma} w^{-k-2} dw$ , where  $-k - 2 \geq 0$ ). Finally, for  $k = -1$ , we can use Exercise 15 of Chapter 4. Because all the other terms give a zero integral,  $c_{-1}$  is the only term of the series which survives:

$$\int_{\gamma} f = \sum_{k \in \mathbb{Z}} c_k \int_{\gamma} (z - z_0)^k dz = 2\pi i c_{-1}.$$

(One might also notice that Theorem 8.16 gives the same identity.) Reason enough to give the  $c_{-1}$ -coefficient of a Laurent series a special name.

**Definition 9.8.** Suppose  $z_0$  is an isolated singularity of  $f$  with Laurent series  $\sum_{k \in \mathbb{Z}} c_k (z - z_0)^k$  in a punctured disk about  $z_0$ . Then  $c_{-1}$  is the *residue of  $f$  at  $z_0$* , denoted by  $\text{Res}_{z=z_0}(f(z))$  or  $\text{Res}(f(z), z = z_0)$ .

The following theorem generalizes the discussion at the beginning of this section.

**Theorem 9.9** (Residue Theorem). *Suppose  $f$  is holomorphic in the region  $G$ , except for isolated singularities, and  $\gamma$  is a positively oriented, simple, closed, smooth,  $G$ -contractible curve which avoids the singularities of  $f$ . Then*

$$\int_{\gamma} f = 2\pi i \sum_k \text{Res}_{z=z_k}(f(z)),$$

where the sum is taken over all singularities  $z_k$  inside  $\gamma$ .

*Proof.* Draw two circles around each isolated singularity inside  $\gamma$ , one with positive, and one with negative orientation, as pictured in Figure 9.1. Each of these pairs cancel each other when we integrate over them. Now connect the circles with negative orientation with  $\gamma$ . This gives a curve which is contractible in the region of holomorphicity of  $f$ . But this means that we can replace  $\gamma$  by the positively oriented circles; now all we need to do is described at the beginning of this section.  $\square$

Computing integrals is as easy (or hard!) as computing residues. The following two lemmas start the range of tricks one can use when computing residues.

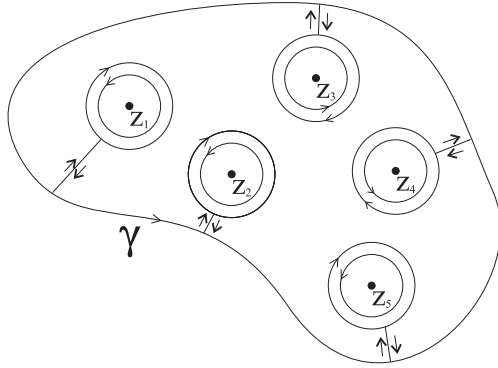

Figure 9.1: Proof of Theorem 9.9.

**Lemma 9.10.** *Suppose  $f$  and  $g$  are holomorphic in a region containing  $z_0$ , which is a zero of  $g$  of multiplicity 1, and  $f(z_0) \neq 0$ . Then  $\frac{f}{g}$  has a pole of order 1 at  $z_0$  and*

$$\operatorname{Res}_{z=z_0} \left( \frac{f(z)}{g(z)} \right) = \frac{f(z_0)}{g'(z_0)}.$$

*Proof.* The functions  $f$  and  $g$  have power series centered at  $z_0$ ; the one for  $g$  has by assumption no constant term:

$$g(z) = \sum_{k \geq 1} c_k (z - z_0)^k = (z - z_0) \sum_{k \geq 1} c_k (z - z_0)^{k-1}.$$

The series on the right represents an holomorphic function, call it  $h$ ; note that  $h(z_0) = c_1 \neq 0$ . Hence

$$\frac{f(z)}{g(z)} = \frac{f(z)}{(z - z_0)h(z)},$$

and the function  $\frac{f}{h}$  is holomorphic at  $z_0$ . Even more, the residue of  $\frac{f}{g}$  equals the constant term of the power series of  $\frac{f}{h}$  (that's how we get the  $(-1)$ st term of  $\frac{f}{g}$ ). But this constant term is computed, as always, by  $\frac{f(z_0)}{h(z_0)}$ . But  $h(z_0)$ , in turn, is the constant term of  $h$  or the second term of  $g$ , which by Taylor's formula (Corollary 8.3) equals  $g'(z_0)$ .  $\square$

**Lemma 9.11.** *Suppose  $z_0$  is a pole of  $f$  of order  $n$ . Then*

$$\operatorname{Res}_{z=z_0}(f(z)) = \frac{1}{(n-1)!} \lim_{z \rightarrow z_0} \frac{d^{n-1}}{dz^{n-1}} ((z - z_0)^n f(z)).$$

*Proof.* We know by Proposition 9.7 that the Laurent series at  $z_0$  looks like

$$f(z) = \sum_{k \geq -n} c_k (z - z_0)^k.$$

But then

$$(z - z_0)^n f(z) = \sum_{k \geq -n} c_k (z - z_0)^{k+n}$$

represents a power series, and we can use Taylor's formula (Corollary 8.3) to compute  $c_{-1}$ .  $\square$

### 9.3 Argument Principle and Rouché's Theorem

There are many situations where we want to restrict ourselves to functions which are holomorphic in some region except possibly for poles. Such functions are called *meromorphic*. In this section, we will study these functions, especially with respect to their zeros and poles, which—as the reader might have guessed already—can be thought of as siblings.

Suppose we have a differentiable function  $f$ . Differentiating  $\mathcal{L}og f$  (where  $\mathcal{L}og$  is a branch of the logarithm) gives  $\frac{f'}{f}$ , which is one good reason why this quotient is called the *logarithmic derivative* of  $f$ . It has some remarkable properties, one of which we would like to discuss here.

Let's say we have two functions  $f$  and  $g$  holomorphic in some region. Then the logarithmic derivative of their product behaves very nicely:

$$\frac{(fg)'}{fg} = \frac{f'g + fg'}{fg} = \frac{f'}{f} + \frac{g'}{g}.$$

We can apply this fact to the following situation: Suppose that  $f$  is holomorphic on the region  $G$ , and  $f$  has the (finitely many) zeros  $z_1, \dots, z_j$  of order  $n_1, \dots, n_j$ , respectively. Then we can express  $f$  as

$$f(z) = (z - z_1)^{n_1} \cdots (z - z_j)^{n_j} g(z),$$

where  $g$  is also holomorphic in  $G$  and never zero. Let's compute the logarithmic derivative of  $f$  and play the same remarkable cancellation game as above:

$$\begin{aligned} \frac{f'(z)}{f(z)} &= \frac{n_1(z - z_1)^{n_1-1}(z - z_2)^{n_2} \cdots (z - z_j)^{n_j} g(z) + \cdots + (z - z_1)^{n_1} \cdots (z - z_j)^{n_j} g'(z)}{(z - z_1)^{n_1} \cdots (z - z_j)^{n_j} g(z)} \\ &= \frac{n_1}{z - z_1} + \frac{n_2}{z - z_2} + \cdots + \frac{n_j}{z - z_j} + \frac{g'(z)}{g(z)}. \end{aligned}$$

Something similar happens to the poles of  $f$ . We invite the reader to prove that if  $p_1, \dots, p_k$  are all the poles of  $f$  in  $G$  with order  $m_1, \dots, m_k$ , respectively, then the logarithmic derivative of  $f$  can be expressed as

$$\frac{f'(z)}{f(z)} = -\frac{m_1}{z - p_1} - \frac{m_2}{z - p_2} - \cdots - \frac{m_k}{z - p_k} + \frac{g'(z)}{g(z)}, \quad (9.1)$$

where  $g$  is a function without poles in  $G$ . Naturally, we can combine the expressions we got for zeros and poles, which is the starting point of the following theorem.

**Theorem 9.12** (Argument Principle). *Suppose  $f$  is meromorphic in the region  $G$  and  $\gamma$  is a positively oriented, simple, closed, smooth,  $G$ -contractible curve, which does not pass through any zero or pole of  $f$ . Denote by  $Z(f, \gamma)$  the number of zeros of  $f$  inside  $\gamma$ —counted according to multiplicity—and by  $P(f, \gamma)$  the number of poles of  $f$  inside  $\gamma$ , again counted according to order. Then*

$$\frac{1}{2\pi i} \int_{\gamma} \frac{f'}{f} = Z(f, \gamma) - P(f, \gamma).$$

*Proof.* Suppose the zeros of  $f$  inside  $\gamma$  are  $z_1, \dots, z_j$  of multiplicity  $n_1, \dots, n_j$ , respectively, and the poles inside  $\gamma$  are  $p_1, \dots, p_k$  with order  $m_1, \dots, m_k$ , respectively. (You may meditate about the fact why there can only be finitely many zeros and poles inside  $\gamma$ .) In fact, we may shrink  $G$ , if necessary, so that these are the only zeros and poles in  $G$ . Our discussion before the statement of the theorem yielded that the logarithmic derivative of  $f$  can be expressed as

$$\frac{f'(z)}{f(z)} = \frac{n_1}{z - z_1} + \dots + \frac{n_j}{z - z_j} - \frac{m_1}{z - p_1} - \dots - \frac{m_k}{z - p_k} + \frac{g'(z)}{g(z)},$$

where  $g$  is a function which is holomorphic in  $G$  (in particular, without poles) and never zero. Thanks to Exercise 15 of Chapter 4, the integral is easy:

$$\begin{aligned} \int_{\gamma} \frac{f'}{f} &= n_1 \int_{\gamma} \frac{dz}{z - z_1} + \dots + n_j \int_{\gamma} \frac{dz}{z - z_j} - m_1 \int_{\gamma} \frac{dz}{z - p_1} - \dots - m_k \int_{\gamma} \frac{dz}{z - p_k} + \int_{\gamma} \frac{g'}{g} \\ &= 2\pi i (n_1 + \dots + n_j - m_1 - \dots - m_k) + \int_{\gamma} \frac{g'}{g}. \end{aligned}$$

Finally,  $\frac{g'}{g}$  is holomorphic in  $G$  (recall that  $g$  is never zero in  $G$ ), so that Corollary 4.7 (to Cauchy's Theorem 4.6) gives that

$$\int_{\gamma} \frac{g'}{g} = 0. \quad \square$$

As a nice application of the argument principle, we present a famous theorem due to Eugène Rouché (1832–1910)<sup>3</sup>.

**Theorem 9.13** (Rouché's Theorem). *Suppose  $f$  and  $g$  are holomorphic in a region  $G$ , and  $\gamma$  is a positively oriented, simple, closed, smooth,  $G$ -contractible curve such that for all  $z \in \gamma$ ,  $|f(z)| > |g(z)|$ . Then*

$$Z(f + g, \gamma) = Z(f, \gamma).$$

This theorem is of surprising practicality. It allows us to locate the zeros of a function fairly precisely. As an illustration, we prove:

**Example 9.14.** All the roots of the polynomial  $p(z) = z^5 + z^4 + z^3 + z^2 + z + 1$  have absolute value less than two.<sup>4</sup> To see this, let  $f(z) = z^5$  and  $g(z) = z^4 + z^3 + z^2 + z + 1$ , and let  $\gamma$  denote

<sup>3</sup>For more information about Rouché, see

<http://www-groups.dcs.st-and.ac.uk/~history/Biographies/Rouche.html>.

<sup>4</sup>The fundamental theorem of algebra (Theorem 5.7) asserts that  $p$  has five roots in  $\mathbb{C}$ . What's special about the statement of Example 9.14 is that they all have absolute value  $< 2$ . Note also that there is no general formula for computing roots of a polynomial of degree 5. (Although for this  $p$  it's not hard to find one root—and therefore all of them.)

the circle centered at the origin with radius 2. Then for  $z \in \gamma$

$$|g(z)| \leq |z|^4 + |z|^3 + |z|^2 + |z| + 1 = 16 + 8 + 4 + 2 + 1 = 31 < 32 = |z|^5 = |f(z)|.$$

So  $g$  and  $f$  satisfy the condition of the Theorem 9.13. But  $f$  has just a root of order 5 at the origin, whence

$$Z(p, \gamma) = Z(f + g, \gamma) = Z(f, \gamma) = 5.$$

*Proof of Theorem 9.13.* By our analysis in the beginning of this section and by the argument principle (Theorem 9.12)

$$\begin{aligned} Z(f + g, \gamma) &= \frac{1}{2\pi i} \int_{\gamma} \frac{(f + g)'}{f + g} = \frac{1}{2\pi i} \int_{\gamma} \frac{\left(f \left(1 + \frac{g}{f}\right)\right)'}{f \left(1 + \frac{g}{f}\right)} = \frac{1}{2\pi i} \int_{\gamma} \left(\frac{f'}{f} + \frac{\left(1 + \frac{g}{f}\right)'}{1 + \frac{g}{f}}\right) \\ &= Z(f, \gamma) + \frac{1}{2\pi i} \int_{\gamma} \frac{\left(1 + \frac{g}{f}\right)'}{1 + \frac{g}{f}}. \end{aligned}$$

We are assuming that  $\left|\frac{g}{f}\right| < 1$  on  $\gamma$ , which means that the function  $1 + \frac{g}{f}$  evaluated on  $\gamma$  stays away from the nonpositive real axis. But then  $\text{Log}\left(1 + \frac{g}{f}\right)$  is a well defined holomorphic function on  $\gamma$ . Its derivative is  $\frac{\left(1 + \frac{g}{f}\right)'}{1 + \frac{g}{f}}$ , which implies by Corollary 5.18 that

$$\frac{1}{2\pi i} \int_{\gamma} \frac{\left(1 + \frac{g}{f}\right)'}{1 + \frac{g}{f}} = 0. \quad \square$$

## Exercises

1. Prove (9.1).
2. Suppose that  $f(z)$  has a zero of multiplicity  $m$  at  $a$ . Explain why  $\frac{1}{f(z)}$  has a pole of order  $m$  at  $a$ .
3. Find the poles of the following, and determine their orders:
  - (a)  $(z^2 + 1)^{-3}(z - 1)^{-4}$ .
  - (b)  $z \cot(z)$ .
  - (c)  $z^{-5} \sin(z)$ .
  - (d)  $\frac{1}{1 - e^z}$ .
  - (e)  $\frac{z}{1 - e^z}$ .
4. Show that if  $f$  has an essential singularity at  $z_0$  then  $\frac{1}{f}$  also has an essential singularity at  $z_0$ .
5. Suppose  $f$  is a non-constant entire function. Prove that any complex number is arbitrarily close to a number in  $f(\mathbb{C})$ . (*Hint:* If  $f$  is not a polynomial, use Theorem 9.6 for  $f\left(\frac{1}{z}\right)$ .)

6. Suppose  $f$  is meromorphic in the region  $G$ ,  $g$  is holomorphic in  $G$ , and  $\gamma$  is a positively oriented, simple, closed,  $G$ -contractible curve, which does not pass through any zero or pole of  $f$ . Denote the zeros and poles of  $f$  inside  $\gamma$  by  $z_1, \dots, z_j$  and  $p_1, \dots, p_k$ , respectively, counted according to multiplicity. Prove that

$$\frac{1}{2\pi i} \int_{\gamma} g \frac{f'}{f} = \sum_{m=1}^j g(z_m) - \sum_{n=1}^k g(p_n).$$

7. Find the number of zeros of

- (a)  $3 \exp z - z$  in  $\{z \in \mathbb{C} : |z| \leq 1\}$  ;  
 (b)  $\frac{1}{3} \exp z - z$  in  $\{z \in \mathbb{C} : |z| \leq 1\}$  ;  
 (c)  $z^4 - 5z + 1$  in  $\{z \in \mathbb{C} : 1 \leq |z| \leq 2\}$  .

8. Give another proof of the fundamental theorem of algebra (Theorem 5.7), using Rouché's Theorem 9.13. (*Hint:* If  $p(z) = a_n z^n + a_{n-1} z^{n-1} + \dots + a_1 z + 1$ , let  $f(z) = a_n z^n$  and  $g(z) = a_{n-1} z^{n-1} + a_{n-2} z^{n-2} + \dots + a_1 z + 1$ , and choose as  $\gamma$  a circle which is large enough to make the condition of Rouché's theorem work. You might want to first apply Lemma 5.6 to  $g(z)$ .)

9. (a) Find a Laurent series for  $\frac{1}{(z^2-4)(z-2)}$  centered at  $z = 2$  and specify the region in which it converges.  
 (b) Compute  $\int_{\gamma} \frac{dz}{(z^2-4)(z-2)}$ , where  $\gamma$  is the positively oriented circle centered at 2 of radius 1.

10. Evaluate the following integrals for  $\gamma(t) = 3e^{it}$ ,  $0 \leq t \leq 2\pi$ .

- (a)  $\int_{\gamma} \cot z \, dz$   
 (b)  $\int_{\gamma} z^3 \cos\left(\frac{3}{z}\right) \, dz$   
 (c)  $\int_{\gamma} \frac{dz}{(z+4)(z^2+1)}$   
 (d)  $\int_{\gamma} z^2 \exp\left(\frac{1}{z}\right) \, dz$   
 (e)  $\int_{\gamma} \frac{\exp z}{\sinh z} \, dz$   
 (f)  $\int_{\gamma} \frac{i^{z+4}}{(z^2+16)^2} \, dz$

11. (a) Find the power series of  $\exp z$  centered at  $z = -1$ .  
 (b) Find  $\int_{\gamma} \frac{\exp z}{(z+1)^{34}} \, dz$ , where  $\gamma$  is the circle  $|z+2| = 2$ , positively oriented.

12. Suppose  $f$  has a simple pole (i.e., a pole of order 1) at  $z_0$  and  $g$  is holomorphic at  $z_0$ . Prove that

$$\operatorname{Res}_{z=z_0}(f(z)g(z)) = g(z_0) \cdot \operatorname{Res}_{z=z_0}(f(z)).$$

13. Find the residue of each function at 0:

(a)  $z^{-3} \cos(z)$ .

(b)  $\csc(z)$ .

(c)  $\frac{z^2 + 4z + 5}{z^2 + z}$ .

(d)  $e^{1-\frac{1}{z}}$ .

(e)  $\frac{e^{4z} - 1}{\sin^2 z}$ .

14. Use residues to evaluate the following:

(a)  $\int_{\gamma} \frac{dz}{z^4 + 4}$ , where  $\gamma$  is the circle  $|z + 1 - i| = 1$ .

(b)  $\int_{\gamma} \frac{dz}{z(z^2 + z - 2)}$ , where  $\gamma$  is the circle  $|z - i| = 2$ .

(c)  $\int_{\gamma} \frac{e^z dz}{z^3 + z}$ , where  $\gamma$  is the circle  $|z| = 2$ .

(d)  $\int_{\gamma} \frac{dz}{z^2 \sin z}$ , where  $\gamma$  is the circle  $|z| = 1$ .

15. Suppose  $f$  has an isolated singularity at  $z_0$ .

(a) Show that  $f'$  also has an isolated singularity at  $z_0$ .

(b) Find  $\text{Res}_{z=z_0}(f')$ .

16. Given  $R > 0$ , let  $\gamma_R$  be the half circle defined by  $\gamma_R(t) = Re^{it}$ ,  $0 \leq t \leq \pi$ , and  $\Gamma_R$  be the closed curve composed of  $\gamma_R$  and the line segment  $[-R, R]$ .

(a) Compute  $\int_{\Gamma_R} \frac{dz}{(1+z^2)^2}$ .

(b) Prove that  $\lim_{R \rightarrow \infty} \int_{\gamma_R} \frac{dz}{(1+z^2)^2} = 0$ .

(c) Combine (a) and (b) to evaluate the real integral  $\int_{-\infty}^{\infty} \frac{dx}{(1+x^2)^2}$ .

17. Suppose  $f$  is entire, and  $a, b \in \mathbb{C}$  with  $|a|, |b| < R$ . Let  $\gamma$  be the circle centered at 0 with radius  $R$ . Evaluate

$$\int_{\gamma} \frac{f(z)}{(z-a)(z-b)} dz,$$

and use this to give an alternate proof of Liouville's Theorem 5.9. (*Hint*: Show that if  $f$  is bounded then the above integral goes to zero as  $R$  increases.)

## Chapter 10

# Discrete Applications of the Residue Theorem

*All means (even continuous) sanctify the discrete end.*  
Doron Zeilberger

On the surface, this chapter is just a collection of exercises. They are more involved than any of the ones we've given so far at the end of each chapter, which is one reason why we lead the reader through each of the following ones step by step. On the other hand, these sections should really be thought of as a continuation of the lecture notes, just in a different format. All of the following 'problems' are of a *discrete* mathematical nature, and we invite the reader to solve them using *continuous* methods—namely, complex integration. It might be that there is no other result which so intimately combines discrete and continuous mathematics as does the Residue Theorem 9.9.

### 10.1 Infinite Sums

In this exercise, we evaluate—as an example—the sums  $\sum_{k \geq 1} \frac{1}{k^2}$  and  $\sum_{k \geq 1} \frac{(-1)^k}{k^2}$ . We hope the idea how to compute such sums in general will become clear.

1. Consider the function  $f(z) = \frac{\pi \cot(\pi z)}{z^2}$ . Compute the residues at all the singularities of  $f$ .
2. Let  $N$  be a positive integer and  $\gamma_N$  be the rectangular curve from  $N+1/2-iN$  to  $N+1/2+iN$  to  $-N-1/2+iN$  to  $-N-1/2-iN$  back to  $N+1/2-iN$ .
  - (a) Show that for all  $z \in \gamma_N$ ,  $|\cot(\pi z)| < 2$ . (Use Exercise 30 in Chapter 3.)
  - (b) Show that  $\lim_{N \rightarrow \infty} \int_{\gamma_N} f = 0$ .
3. Use the Residue Theorem 9.9 to arrive at an identity for  $\sum_{k \in \mathbb{Z} \setminus \{0\}} \frac{1}{k^2}$ .
4. Evaluate  $\sum_{k \geq 1} \frac{1}{k^2}$ .
5. Repeat the exercise with the function  $f(z) = \frac{\pi}{z^2 \sin(\pi z)}$  to arrive at an evaluation of

$$\sum_{k \geq 1} \frac{(-1)^k}{k^2}.$$



(Hint: To bound this function, you may use the fact that  $1/\sin^2 z = 1 + \cot^2 z$ .)

6. Evaluate  $\sum_{k \geq 1} \frac{1}{k^4}$  and  $\sum_{k \geq 1} \frac{(-1)^k}{k^4}$ .

## 10.2 Binomial Coefficients

The binomial coefficient  $\binom{n}{k}$  is a natural candidate for being explored analytically, as the binomial theorem<sup>1</sup> tells us that  $\binom{n}{k}$  is the coefficient of  $z^k$  in  $(1+z)^n$ . As an example, we outline a proof of the identity (for  $-1/4 < x < 1/4$ )

$$\sum_{k \geq 0} \binom{2k}{k} x^k = \frac{1}{\sqrt{1-4x}}.$$

1. Convince yourself that

$$\binom{2k}{k} = \frac{1}{2\pi i} \int_{\gamma} \frac{(1+w)^{2k}}{w^{k+1}} dw,$$

where  $\gamma$  is any simple closed curve such that 0 is inside  $\gamma$ .

2. Suppose  $|x| < 1/4$ . Find a simple closed curve  $\gamma$  surrounding the origin such that

$$\sum_{k \geq 0} \left( \frac{(1+w)^2}{w} x \right)^k$$

converges uniformly on  $\gamma$  (as a function in  $w$ ). Evaluate this sum.

3. Convince yourself that

$$\sum_{k \geq 0} \binom{2k}{k} x^k = \frac{1}{2\pi i} \sum_{k \geq 0} \int_{\gamma} \frac{(1+w)^{2k}}{w^k} x^k \frac{dw}{w},$$

use 2. to interchange summation and integral, and use the Residue Theorem 9.9 to evaluate the integral.

## 10.3 Fibonacci Numbers

The *Fibonacci numbers* are a sequence of integers defined recursively as:

$$\begin{aligned} f_0 &= 1, \\ f_1 &= 1, \\ f_n &= f_{n-1} + f_{n-2} \quad \text{for } n \geq 2. \end{aligned}$$

Let  $F(z) = \sum_{k \geq 0} f_k z^k$ .

<sup>1</sup>The binomial theorem says that for  $x, y \in \mathbb{C}$  and  $n \in \mathbb{N}$ ,  $(x+y)^n = \sum_{k=0}^n \binom{n}{k} x^k y^{n-k}$ .

<sup>2</sup>For more information about Leonardo Pisano Fibonacci (1170–1250), see <http://www-groups.dcs.st-and.ac.uk/~history/Biographies/Fibonacci.html>.

1. Show that  $F$  has a positive radius of convergence.
2. Show that the recurrence relation among the  $f_n$  implies that  $F(z) = \frac{1}{1-z-z^2}$ . (*Hint*: Write down the power series of  $zF(z)$  and  $z^2F(z)$  and rearrange both so that you can easily add.)
3. Verify that  $\operatorname{Res}_{z=0} \left( \frac{1}{z^{n+1}(1-z-z^2)} \right) = f_n$ .
4. Use the Residue Theorem 9.9 to derive an identity for  $f_n$ . (*Hint*: Integrate  $\frac{1}{z^{n+1}(1-z-z^2)}$  around a circle with center 0 and radius  $R$ , and show that this integral vanishes as  $R \rightarrow \infty$ .)
5. Generalize to other recurrence relations.

## 10.4 The ‘Coin-Exchange Problem’

In this exercise, we will solve and extend a classical problem of Ferdinand Georg Frobenius (1849–1917)<sup>3</sup>. Suppose  $a$  and  $b$  are relatively prime<sup>4</sup> positive integers, and  $t$  is a positive integer. Consider the function

$$f(z) = \frac{1}{(1-z^a)(1-z^b)z^{t+1}}.$$

1. Compute the residues at all non-zero poles of  $f$ .
2. Verify that  $\operatorname{Res}_{z=0}(f) = N(t)$ , where

$$N(t) = \#\{(m, n) \in \mathbb{Z} : m, n \geq 0, ma + nb = t\}.$$

3. Use the Residue Theorem 9.9 to derive an identity for  $N(t)$ . (*Hint*: Integrate  $f$  around a circle with center 0 and radius  $R$ , and show that this integral vanishes as  $R \rightarrow \infty$ .)
4. Use the following three steps to simplify this identity to

$$N(t) = \frac{t}{ab} - \left\{ \frac{b^{-1}t}{a} \right\} - \left\{ \frac{a^{-1}t}{b} \right\} + 1.$$

Here,  $\{x\}$  denotes the fractional part<sup>5</sup> of  $x$ , and  $a^{-1}a \equiv 1 \pmod{b}$ <sup>6</sup>, and  $b^{-1}b \equiv 1 \pmod{a}$ .

- (a) Verify that for  $b = 1$ ,

$$\begin{aligned} N(t) &= \#\{(m, n) \in \mathbb{Z} : m, n \geq 0, ma + n = t\} = \#\{m \in \mathbb{Z} : m \geq 0, ma \leq t\} \\ &= \#\left( \left[ 0, \frac{t}{a} \right] \cap \mathbb{Z} \right) = \frac{t}{a} - \left\{ \frac{t}{a} \right\} + 1. \end{aligned}$$

<sup>3</sup>For more information about Frobenius, see

<http://www-groups.dcs.st-and.ac.uk/~history/Biographies/Frobenius.html>.

<sup>4</sup>this means that the integers don't have any common factor

<sup>5</sup>The fractional part of a real number  $x$  is, loosely speaking, the “part after the decimal point.” More thoroughly, the *greatest integer function* of  $x$ , denoted by  $[x]$ , is the greatest integer not exceeding  $x$ . The fractional part is then  $\{x\} = x - [x]$ .

<sup>6</sup>This means that  $a^{-1}$  is an integer such that  $a^{-1}a = 1 + kb$  for some  $k \in \mathbb{Z}$ .

(b) Use this together with the identity found in 3. to obtain

$$\frac{1}{a} \sum_{k=1}^{a-1} \frac{1}{(1 - e^{2\pi ik/a})e^{2\pi ikt/a}} = - \left\{ \frac{t}{a} \right\} + \frac{1}{2} - \frac{1}{2a}.$$

(c) Verify that

$$\sum_{k=1}^{a-1} \frac{1}{(1 - e^{2\pi ikb/a})e^{2\pi ikt/a}} = \sum_{k=1}^{a-1} \frac{1}{(1 - e^{2\pi ik/a})e^{2\pi ikb^{-1}t/a}}.$$

5. Prove that  $N(ab - a - b) = 0$ , and  $N(t) > 0$  for all  $t > ab - a - b$ .

6. More generally, prove that, if  $k$  is a nonnegative integer,  $N((k+1)ab - a - b) = k$ , and  $N(t) > k$  for all  $t > (k+1)ab - a - b$ .

*Historical remark.* Given relatively prime positive integers  $a_1, \dots, a_n$ , let's call an integer  $t$  *representable* if there exist nonnegative integers  $m_1, \dots, m_n$  such that

$$t = \sum_{j=1}^n m_j a_j.$$

In the late 19th century, Frobenius raised the problem of finding the largest integer which is not representable. We call this largest integer the *Frobenius number*  $g(a_1, \dots, a_n)$ . It is well known (probably at least since the 1880's, when James Joseph Sylvester (1814–1897)<sup>7</sup> studied the Frobenius problem) that  $g(a_1, a_2) = a_1 a_2 - a_1 - a_2$ . We verified this result in 5. For  $n > 2$ , there is no known closed formula for  $g(a_1, \dots, a_n)$ . The formula in 4. is due to Popoviciu. The notion of an integer being representable  $k$  times and the respective formula obtained in 6. can only be found in the most recent literature.

## 10.5 Dedekind sums

This exercise outlines yet another nontraditional application of the Residue Theorem 9.9. Given two positive, relatively prime integers  $a$  and  $b$ , let

$$f(z) = \cot(\pi az) \cot(\pi bz) \cot(\pi z).$$

1. Choose an  $\epsilon > 0$  such that the rectangular path  $\gamma_R$  from  $1 - \epsilon - iR$  to  $1 - \epsilon + iR$  to  $-\epsilon + iR$  to  $-\epsilon - iR$  back to  $1 - \epsilon - iR$  does not pass through any of the poles of  $f$ .

(a) Compute the residues for the poles of  $f$  inside  $\gamma_R$ .

*Hint:* use the periodicity of the cotangent and the fact that

$$\cot z = \frac{1}{z} - \frac{1}{3}z + \text{higher-order terms}.$$

<sup>7</sup>For more information about Sylvester, see <http://www-groups.dcs.st-and.ac.uk/~history/Biographies/Sylvester.html>.

(b) Prove that  $\lim_{R \rightarrow \infty} \int_{\gamma_R} f = -2i$  and deduce that for any  $R > 0$

$$\int_{\gamma_R} f = -2i.$$

2. Define

$$s(a, b) = \frac{1}{4b} \sum_{k=1}^{b-1} \cot\left(\frac{\pi ka}{b}\right) \cot\left(\frac{\pi k}{b}\right). \quad (10.1)$$

Use the Residue Theorem 9.9 to show that

$$s(a, b) + s(b, a) = -\frac{1}{4} + \frac{1}{12} \left( \frac{a}{b} + \frac{1}{ab} + \frac{b}{a} \right). \quad (10.2)$$

3. Can you generalize (10.1) and (10.2)?

*Historical remark.* The sum (10.1) is called a *Dedekind<sup>8</sup> sum*. It first appeared in the study of the *Dedekind  $\eta$ -function*

$$\eta(z) = \exp\left(\frac{\pi iz}{12}\right) \prod_{k \geq 1} (1 - \exp(2\pi ikz))$$

in the 1870's and has since intrigued mathematicians from such different areas as topology, number theory, and discrete geometry. The *reciprocity law* (10.2) is the most important and famous identity of the Dedekind sum. The proof that is outlined here is due to Hans Rademacher (1892–1969)<sup>9</sup>.

---

<sup>8</sup>For more information about Julius Wilhelm Richard Dedekind (1831–1916), see <http://www-groups.dcs.st-and.ac.uk/~history/Biographies/Dedekind.html>.

<sup>9</sup>For more information about Rademacher, see <http://www-groups.dcs.st-and.ac.uk/~history/Biographies/Rademacher.html>.

# Solutions to Selected Exercises

## Chapter 1

2. (b)  $\frac{19}{25} - \frac{8}{25}i$   
(c) 1  
(d) 1 if  $n = 4k$ ,  $k \in \mathbb{Z}$ ;  $i$  if  $n = 1 + 4k$ ,  $k \in \mathbb{Z}$ ;  $-1$  if  $n = 2 + 4k$ ,  $k \in \mathbb{Z}$ ;  $-i$  if  $n = 3 + 4k$ ,  $k \in \mathbb{Z}$ .
3. (a)  $\sqrt{5}$ ,  $-2 - i$   
(b)  $5\sqrt{5}$ ,  $5 - 10i$   
(c)  $\sqrt{\frac{10}{11}}$ ,  $\frac{3}{11}(\sqrt{2} - 1) + \frac{i}{11}(\sqrt{2} + 9)$   
(d) 8,  $8i$
4. (a)  $2e^{i\frac{\pi}{2}}$   
(b)  $\sqrt{2}e^{i\frac{\pi}{4}}$   
(c)  $2\sqrt{3}e^{i\frac{5\pi}{6}}$
5. (a)  $-1 + i$   
(b)  $34i$   
(c)  $-1$
10. (a)  $z = e^{i\frac{\pi}{3}k}$ ,  $k = 0, 1, \dots, 5$   
(b)  $z = 2e^{i\frac{\pi}{4} + \frac{\pi}{2}k}$ ,  $k = 0, 1, 2, 3$
13.  $z = e^{i\frac{\pi}{4}} - 1$  and  $z = e^{i\frac{5\pi}{4}} - 1$

## Chapter 2

2. (a) 0  
(b)  $1 + i$
12. (a) differentiable and holomorphic in  $\mathbb{C}$  with derivative  $-e^{-x}e^{-iy}$   
(b) nowhere differentiable or holomorphic  
(c) differentiable on  $\{x + iy \in \mathbb{C} : x = y\}$  with derivative  $2x$ , nowhere holomorphic  
(d) nowhere differentiable or holomorphic  
(e) differentiable and holomorphic in  $\mathbb{C}$  with derivative  $-\sin x \cosh y - i \cos x \sinh y$   
(f) nowhere differentiable or holomorphic  
(g) differentiable at 0 with derivative 0, nowhere holomorphic  
(h) differentiable at 0 with derivative 0, nowhere holomorphic  
(i) differentiable at  $i$  with derivative  $i$ , nowhere holomorphic  
(j) differentiable on  $\{x + iy \in \mathbb{C} : x = y\}$  with derivative  $2x - 2ix$ , nowhere holomorphic  
(k) differentiable at 0 with derivative 0, nowhere holomorphic  
(l) differentiable and holomorphic in  $\mathbb{C}$  with derivative  $2(z - \bar{z})$

**Chapter 3**

37. (a) differentiable at 0, nowhere holomorphic  
 (b) differentiable and holomorphic on  $\mathbb{C} \setminus \{-1, e^{i\frac{\pi}{3}}, e^{-i\frac{\pi}{3}}\}$   
 (c) differentiable and holomorphic on  $\mathbb{C} \setminus \{x + iy \in \mathbb{C} : x \geq -1, y = 2\}$   
 (d) nowhere differentiable or holomorphic  
 (e) differentiable and holomorphic on  $\mathbb{C} \setminus \{x + iy \in \mathbb{C} : x \leq 3, y = 0\}$   
 (f) differentiable and holomorphic in  $\mathbb{C}$  (i.e. entire)
38. (a)  $z = i$   
 (b) There is no solution.  
 (c)  $z = \ln \pi + i\left(\frac{\pi}{2} + 2\pi k\right)$ ,  $k \in \mathbb{Z}$   
 (d)  $z = \frac{\pi}{2} + 2\pi k \pm 4i$ ,  $k \in \mathbb{Z}$   
 (e)  $z = \frac{\pi}{2} + \pi k$ ,  $k \in \mathbb{Z}$   
 (f)  $z = \pi ki$ ,  $k \in \mathbb{Z}$   
 (g)  $z = \pi k$ ,  $k \in \mathbb{Z}$   
 (h)  $z = 2i$
41.  $f'(z) = cz^{c-1}$

**Chapter 4**

3.  $-2\pi i$
4. (a)  $8\pi i$   
 (b) 0  
 (c) 0  
 (d) 0
21. 0
23.  $\frac{2\pi}{\sqrt{3}}$
- 30 0 for  $r < |a|$ ;  $2\pi i$  for  $r > |a|$
- 31 0 for  $r = 1$ ;  $-\frac{\pi i}{3}$  for  $r = 3$ ; 0 for  $r = 5$

**Chapter 5**

3. (a) 0  
 (b)  $2\pi i$   
 (c) 0  
 (d)  $\pi i$   
 (e) 0  
 (f) 0
7. Any simply connected set which does not contain the origin, for example,  $\mathbb{C} \setminus (-\infty, 0]$ .

**Chapter 7**

2. (a) divergent  
 (b) convergent (limit 0)  
 (c) divergent  
 (d) convergent (limit  $2 - \frac{i}{2}$ )  
 (e) convergent (limit 0)

24. (a)  $\sum_{k \geq 0} (-4)^k z^k$   
 (b)  $\sum_{k \geq 0} \frac{1}{3 \cdot 6^k} z^k$
27. (a)  $\sum_{k \geq 0} (-1)^k (z-1)^k$   
 (b)  $\sum_{k \geq 1} \frac{(-1)^{k-1}}{k} (z-1)^k$
30. (a)  $\infty$  if  $|a| < 1$ , 1 if  $|a| = 1$ , and 0 if  $|a| > 1$ .  
 (b) 1  
 (c) 1 (careful reasoning!)  
 (d) 1 (careful reasoning!)

**Chapter 8**

1. (a)  $\{z \in \mathbb{C} : |z| < 1\}$ ,  $\{z \in \mathbb{C} : |z| \leq r\}$  for any  $r < 1$   
 (b)  $\mathbb{C}$ ,  $\{z \in \mathbb{C} : |z| \leq r\}$  for any  $r$   
 (c)  $\{z \in \mathbb{C} : |z-3| > 1\}$ ,  $\{z \in \mathbb{C} : r \leq |z-3| \leq R\}$  for any  $1 < r \leq R$
3.  $\sum_{k \geq 0} \frac{e}{k!} (z-1)^k$
10. The maximum is 3 (attained at  $z = \pm i$ ), and the minimum is 1 (attained at  $z = \pm 1$ ).
12. One Laurent series is  $\sum_{k \geq 0} (-2)^k (z-1)^{-k-2}$ , converging for  $|z-1| > 2$ .
13. One Laurent series is  $\sum_{k \geq 0} (-2)^k (z-2)^{-k-3}$ , converging for  $|z-2| > 2$ .
14. One Laurent series is  $-3(z+1)^{-1} + 1$ , converging for  $z \neq -1$ .
15.  $\frac{1}{\sin z} = z^{-1} + \frac{1}{6}z + \frac{7}{360}z^3 + \dots$
20. (a)  $\sum_{k \geq 0} \frac{(-1)^k}{(2k)!} z^{2k-2}$

**Chapter 9**

7. (a) 0  
 (b) 1  
 (c) 4
9. (a) One Laurent series is  $\sum_{k \geq -2} \frac{(-1)^k}{4^{k+3}} (z-2)^k$ , converging for  $0 < |z-2| < 4$ .  
 (b)  $-\frac{\pi i}{8}$
10. (a)  $2\pi i$   
 (b)  $\frac{27\pi i}{4}$   
 (c)  $-\frac{2\pi i}{1} 7$   
 (d)  $\frac{\pi i}{3}$   
 (e)  $2\pi i$   
 (f) 0
11. (a)  $\sum_{k \geq 0} \frac{1}{e k!} (z+1)^k$   
 (b)  $\frac{2\pi i}{e 33!}$
16. (c)  $\frac{\pi}{2}$