

A Novel Interleaved Buck Converter with Closed Loop Control

Arya Raveendran¹, Geetha B², Annie P Oommen³

¹P.G. Student, Mar Athanasius College of Engineering, Kothamangalam, Kerala

^{2,3} Professor, Mar Athanasius College of Engineering, Kothamangalam, Kerala

Abstract:- The paper presents a new Interleaved Buck Converter with feedback control. Closed loop control provides a good regulated output voltage. Proposed IBC is suitable for application where input voltage is high and operating duty cycle is less than 50%. In this IBC two active switches are connected in series and a coupling capacitor is employed in the power path. It shows that the voltage stress across all the active switches is half of the input voltage before turn-on or after turn-off when the operating duty is below 50%. So the capacitive discharging and switching losses can be reduced considerably. It allows proposed IBC to have higher efficiency and operate with higher switching frequency. In addition, the proposed IBC has a higher step-down conversion ratio and a smaller output current ripple compared with a conventional IBC. Simulation can be carried out to study the performance of the proposed topology in MATLAB/SIMULINK environment. With closed loop control a better output voltage is obtained.

Keywords:- Interleaved, Buck, PWM, Closed loop

I. INTRODUCTION

Interleaving technique connects dc-dc converter in parallel to share the power flow between two or more conversion chains. It implies a reduction in the size, weight and volume of the inductors and capacitors. Also a proper control of the parallel converters increases the ripple frequency and reduces the ripple waveforms at the input and output of the power conversion system, which leads to a significant reduction of current and voltage ripples.[6 7]

This paper presents new topology of interleaved buck converter. Due to the simple structure and low control complexity of interleaved buck converter, it is used in applications where non isolation, step down conversion ratio, high output current with low ripple is required. But in conventional IBC, the active switches suffer from the input source voltage due to its parallel connection with the source. So high voltage devices should be used. But high voltage rated devices is characterized with high forward voltage drop, high cost, intense reverse recovery, high on resistance. Due to the hard switching condition, the operating efficiency is very poor. For getting good dynamics and higher power density converter requires to operate at higher switching frequency. But at higher switching frequency switching losses is increased and thus, efficiency is further reduced.[1]

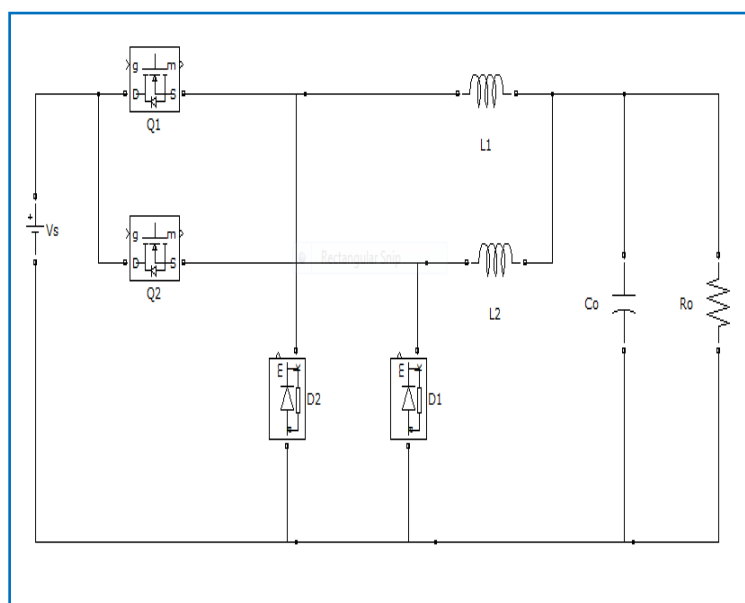

Fig.1. Conventional Interleaved Buck Converter

II. PROPOSED CIRCUIT WITHOUT FEEDBACK

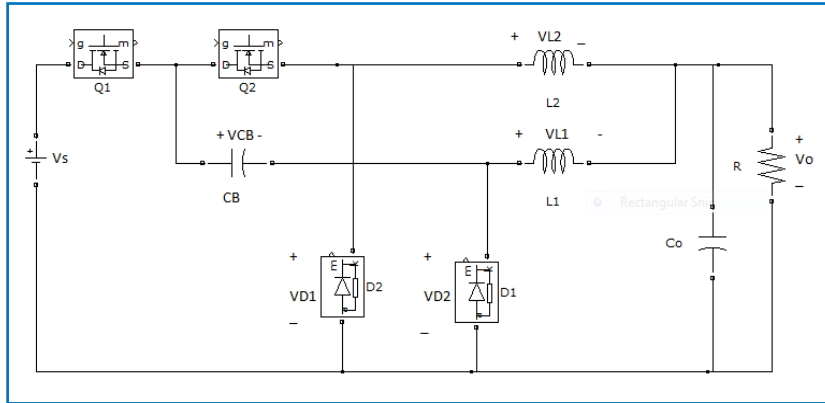

Fig.2.Proposed Interleaved Buck Converter without feedback

In the proposed IBC two switches are connected in series and there is a coupling capacitor in the power path. The two switches Q_1 and Q_2 are activated with a phase shift angle of 180° . The output voltage can be regulated by adjusting the duty cycle at fixed switching frequency. The new IBC is operates at continuous conduction mode .So its current stress is low. The voltage stress of active switches is half of the input voltage before turn on and after turn off under steady state. So the capacitive discharging and switching losses reduces considerably. The voltage stress of freewheeling diode is also considerably reduced. So the reverse recovery and conduction losses on the freewheeling diode improve by using schottky diode which have generally low break down voltage. A good conversion ratio and low output current ripple can be obtained with proposed topology. The new IBC is suitable for applications where the input voltage is high and duty cycle is less than 50% [5].

A. Circuit Operations

One switching period is divided into four modes. For illustrating the operation of IBC ,there are certain assumptions are made such that, the two inductance L_1 and L_2 have the same inductance, all power semiconductor devices are ideal, the coupling capacitor C_B and output capacitor C_O is large enough to be considered as voltage source.

Steady-State Operation when $D \leq 0.5$

Mode 1 [$t_0 - t_1$]: Mode 1 starts with Q_1 is turned on at t_0 . Then, the current of L_1 , flows through Q_1 , C_B , and L_2 and the voltage of the coupling capacitor V_{CB} is charged. The current of L_2 , freewheels through D_2 .

Mode 2 [$t_1 - t_2$]: Mode 2 starts when Q_1 is turned off at t_1 . The current of L_1 and L_2 freewheel through D_1 and D_2 , respectively.

Mode 3 [$t_2 - t_3$]: Mode 3 starts when Q_2 is turned on at t_2 . At this same time, D_2 is turned off. The current, i_{L1} freewheels through D_1 and i_{L2} flows through D_1 , C_B , Q_2 , and L_2 . Thus, V_{CB} is discharged.

Mode 4 [$t_3 - t_4$]: Mode 4 starts when Q_2 is turned off at t_3 , and its operation is the same with that of mode 2. The switching states and voltage across different components during different modes are given in table 1

The steady-state operation of the proposed IBC operating with the duty cycle of $D \leq 0.5$ has been described. From the working principles, it is clear that the voltage stress of all semiconductor devices except Q_2 is not the input voltage, but is determined by the voltage of coupling capacitor V_{CB} . The maximum voltage of Q_2 is the input voltage, but the voltage before turn-on or after turn-off is equal to V_{CB} . As these results, the capacitive discharging and switching losses on Q_1 and Q_2 can be reduced considerably. Also diodes with good characteristics such as schottky can be used for D_1 and D_2 , the reverse-recovery and conduction losses can be also improved.

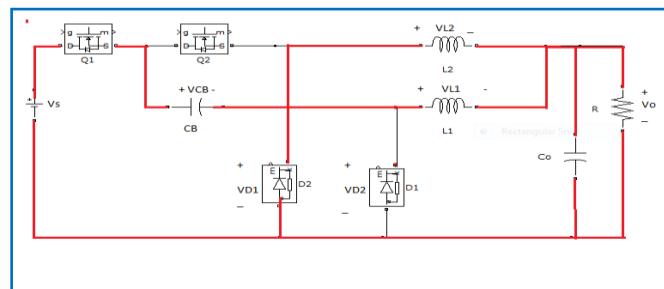

(a)Mode 1

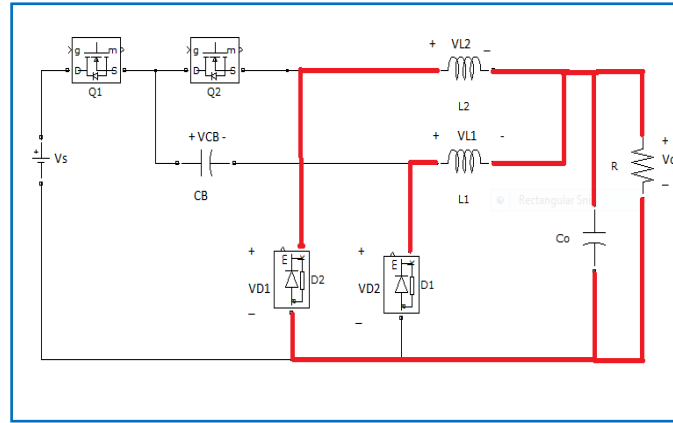

(b) Mode 2 or 4

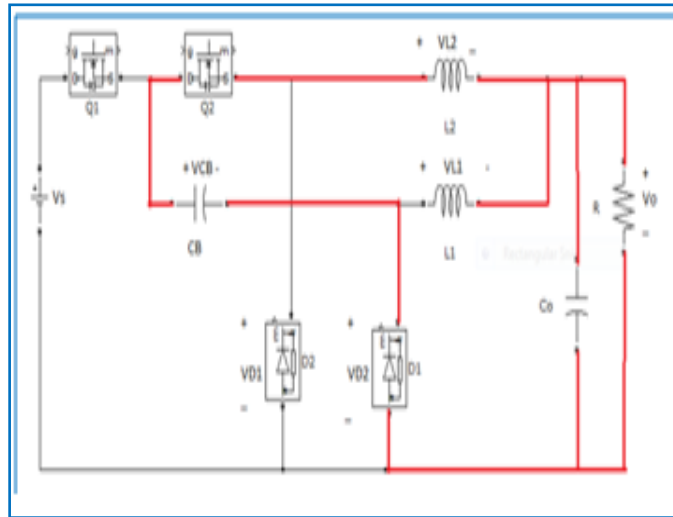

(C) Mode 3

Fig.3. Circuit operations of proposed IBC for $D < 0.5$

Table.1. Switching states and voltage during $D < 0.5$

Mode	Q_1	Q_2	V_{Q1}	V_{Q2}	V_{L1}	V_{L2}	V_{D1}	V_{D2}
MODE1	ON	OFF	0	V_S	$V_S - V_{CB} - V_O$	$-V_O$	$V_S - V_{CB}$	0
MODE2	OFF	OFF	$V_S - V_{CB}$	V_{CB}	$-V_O$	$-V_O$	0	0
MODE3	OFF	ON	$V_S - V_{CB}$	0	$-V_O$	$V_{CB} - V_O$	0	V_{CB}
MODE4	OFF	OFF	$V_S - V_{CB}$	V_{CB}	$-V_O$	$-V_O$	0	0

Steady-State Operation when $D > 0.5$

Mode 1 [$t_0 - t_1$]: Mode 1 starts when Q_2 is in on-state and Q_1 is turned on at t_0 . Then, i_{L1} flows through Q_1 , C_B , and L_1 and V_{CB} is charged. $i_{L2}(t)$ flows through Q_1 , Q_2 , and L_2 .

Mode 2 [$t_1 - t_2$]: Mode 2 starts when Q_2 is turned off at t_1 . Then, i_{L1} flows through Q_1 , C_B , and L_1 and i_{L2} freewheels through D_2 . The operation during this mode is the same with mode 1 in the case of $D \leq 0.5$.

Mode 3 [$t_2 - t_3$]: Mode 3 begins when Q_2 is turned on at t_2 , and the operation is the same with mode 1.

Mode 4 [$t_3 - t_4$]: Mode 4 begins when Q_1 is turned off at t_3 . Then, i_{L1} freewheels through D_1 and i_{L2} flows through D_1 , C_B , Q_2 , and L_2 . Thus, V_{CB} is discharged. The operation during this mode is the same with mode 3 in the case of $D \leq 0.5$. The switching states and voltage across different components during different modes are given in table 2

The operation of the proposed IBC under steady-state operating with $D > 0.5$ is described. During this operating condition, the voltage stress of Q_1 and D_1 is determined by the capacitor voltage V_{CB} , but the voltage stress of Q_2 and D_2 is determined by the input voltage. In addition, since V_{L2} is much larger than V_{L1} during mode1 or mode 3, the unbalance between i_{L1} and i_{L2} occurs. The current of Q_1 , i_{Q1} , is the sum of i_{L1} and i_{L2}

and the current of Q_2 , i_{Q2} , is equal to i_{L2} in mode 1 or mode 3. Therefore, it can be said that switches Q_1 and Q_2 experience high current stress in the case of $D > 0.5$. It can be known that the proposed IBC has advantages in terms of efficiency and component stress in the case of only $D \leq 0.5$. Thus, the proposed IBC is recommended for the applications where the operating duty cycle is smaller than or equal to 0.5.

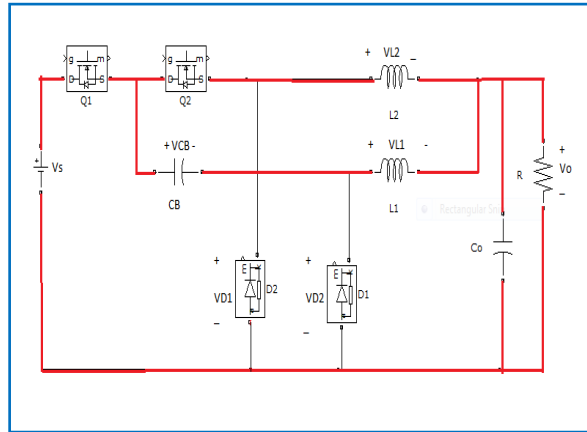

(a) Mode 1 or 3

Fig.4. Circuit operations of proposed IBC for $D > 0.5$

Table.2. Switching states and voltages during $D > 0.5$

Mode	Q_1	Q_2	V_{O1}	V_{O2}	V_{L1}	V_{L2}	V_{D1}	V_{D2}
Mode1	ON	ON	0	0	$V_S - V_{CB} - V_O$	$V_S - V_O$	$V_S - V_{CB}$	V_S
Mode2	ON	OFF	0	V_S	$V_S - V_{CB} - V_O$	$-V_O$	$V_S - V_{CB}$	0
Mode3	ON	ON	0	0	$V_S - V_{CB} - V_O$	$V_S - V_O$	$V_S - V_{CB}$	V_S
Mode4	OFF	ON	$V_S - V_{CB}$	0	$-V_O$	$V_{CB} - V_O$	0	V_{CB}

III. CLOSED LOOP CONTROL OF THE PROPOSED CONVERTER

A. Control Principles

A dc-dc converter should provide a regulated output voltage under varying load and input voltage conditions. The component values of converter are also changing with time, temperature, pressure etc. So the control of the output voltage should be performed in a closed-loop manner using principles of negative feedback.

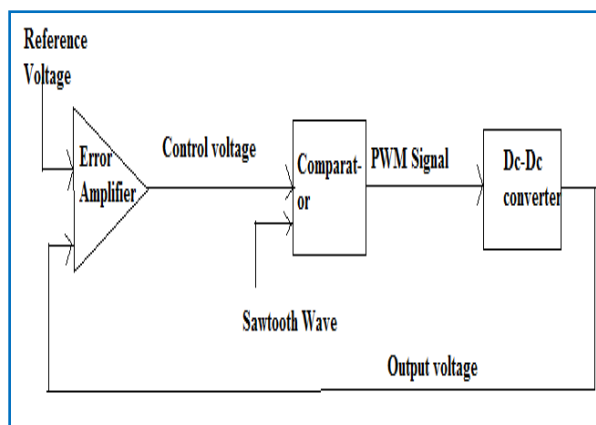

Fig.5. Voltage mode closed loop control

One of the closed loop control method of PWM dc-dc converters is voltage mode control. In the voltage-mode control as shown in Fig.5 the converter output voltage is sensed and subtracted from an external reference voltage in an error amplifier. The error amplifier produces a control voltage that is compared to a constant- amplitude saw-tooth waveform. The comparator produces a PWM signal that is fed to drivers of controllable switches in the dc-dc converter. The duty ratio of the PWM signal depends on the value of the control voltage. The frequency of the PWM signal is the same as the frequency of the saw-tooth waveform.[2]

B. Proportional Integral Controller

PI Controller (proportional-integral controller) is a feedback controller. It produces an output signal consisting two terms. One is proportional to the error signal and the second is proportional to the integral of error signal. The proportional action increases loop gain and integral action reduces steady state error.

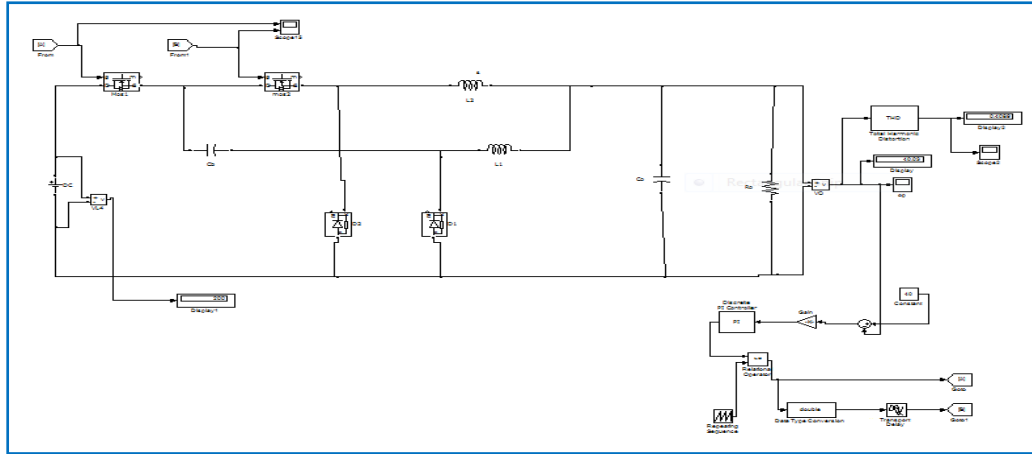

Fig.6. SIMULINK model of proposed interleaved buck converter with closed loop control

IV. SIMULATION RESULTS

Input voltage given to the converter is 200 v and the switching frequency is 50 KHz. It is assumed that operating duty ratio is less than 50%. It is investigated that due to the improved voltage waveforms in the proposed IBC, the capacitive discharging and switching losses are reduced. It can be seen that at higher switching frequency, the increased losses in the proposed IBC are much smaller than that of conventional IBC. It means that the proposed converter can operate at higher switching frequencies without a significant increase in the losses. So, it can be said that the propose IBC is more advantageous in terms of efficiency and power density compared with the conventional IBC. The simulation waveforms using MATLAB are given below.

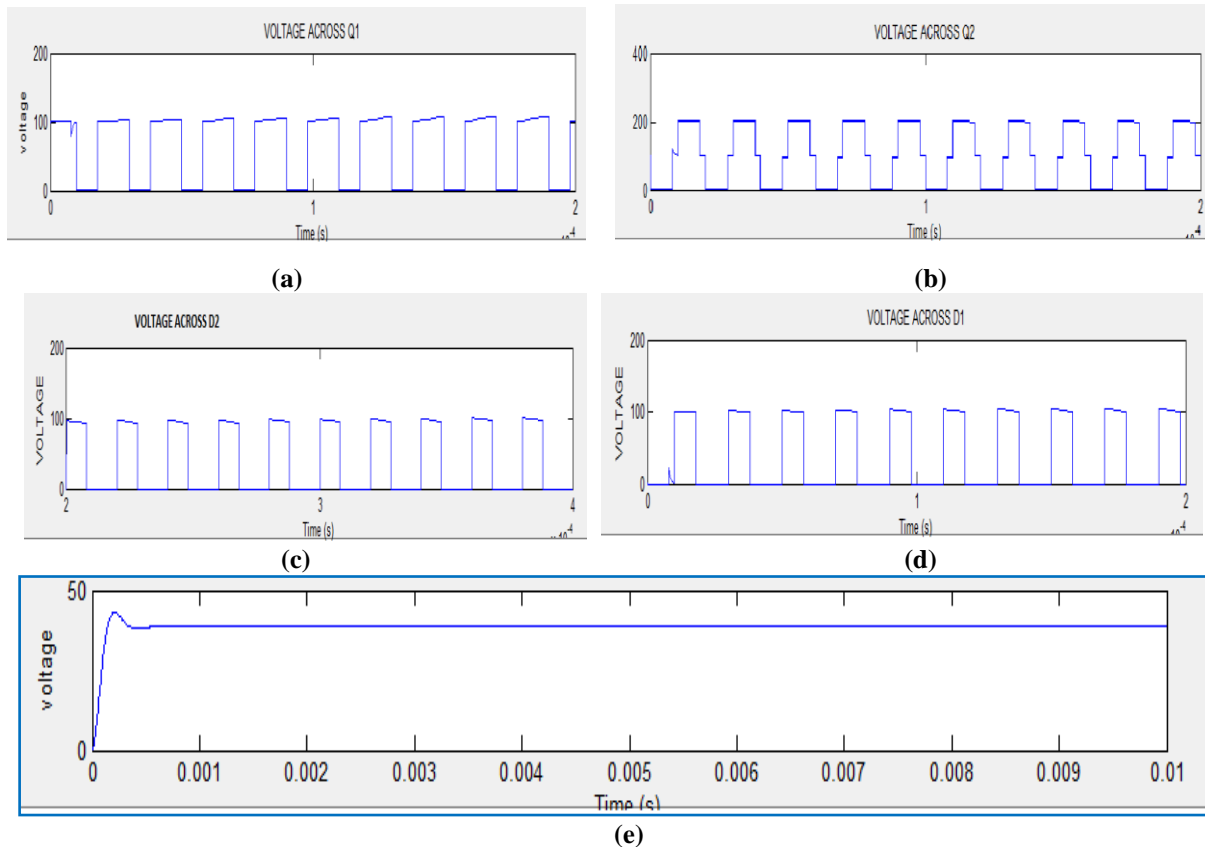

Fig.7.(a)Voltage across Q_1 (b)Voltage across Q_2 (c)Voltage across D_2 (d)Voltage across D_1 (e) Output voltage of proposed converter with closed loop control for $D < 0.5$

Using the principle of inductor volt second balance , voltage conversion ratio of both conventional and proposed IBC can be calculated[4]. The relevant analysis results are tabulated in table.3.

Table.3.Analysis results

Items	Conventional IBC	Proposed IBC
DC conversion ratio	D	.5D for $D < .5$ & D^2 for $D > .5$
Voltage stress of Q1	VS	.5VS
Voltage stress of Q2	VS	VS
Voltage stress of D1 & D2	VS	.5VS

THD of proposed converter without feedback control=56%.THD of proposed converter with feedback control=40%.Using closed loop control the harmonic distortion in output voltage is reduced by 15%.So with a closed loop control better output voltage is obtained.

V. CONCLUSION

The proposed IBC is suitable for the applications where the duty ratio is less than 50% since for the proposed IBC, the voltage stress across active switches is half of the input voltage, when duty ratio is less than 50%.It leads to a significant reduction in capacitive discharging and switching losses. Also voltage stress of freewheeling diode is half of the input voltage. So by employing schottky diodes which have low breakdown voltage, the reverse recovery and conduction losses on freewheeling diode can be improved. The efficiency of proposed IBC can be increased by increasing the switching frequency. Closed loop control provides a good regulated output voltage and also reduces the harmonics in output.THd in the output voltage of a conventional IBC is 56%.With closed loop THD, in the output voltage is decreased by 15%.

REFERENCES

- [1]. Shin Young Cho ,Gun Woo Moon,," Interleaved Buck Converter Having Low Switching losses and Improved Step-Down conversion ratio.
- [2]. IEEE Transactions on Power electronics,vol.27 no.8.August 2012
- [3]. Muhammad H Rashid,"Power Electronics Handbook",Academic Press,USA,2001
- [4]. Ned Mohan ,Tore M.Undeland and William P.Robbins,"Power Electronics",John Wiley Wiley and Sons, Inc.,Publication, USA, 2003
- [5]. R. W. Erickson and D. Maksimovic, Fundamentals of Power Electronics:KluwerAcademic Publisher, 2001, pp. 78–100.
- [6]. K. Yao, Y. Qiu, M. Xu, and F. C. Lee, "A novel winding-coupled buck converter for high- frequency, high-step-down DC–DC conversion," IEEE Trans. Power Electron., vol. 20, no. 5, pp. 1017–1023, Sep. 2005.
- [7]. Arango.E, Ramos-Paja C, Carrejo C,Giral R, Saavedra-Montes, A.J, "A ripple- mitigating pre-amplifier based on interleaved DC-DC boost converters for efficiency improvement", Revista Facultad de Ingenieria 2011, 60, 214–225.
- [8]. Arango, E,Calvente, J,Giral, R, "Asymmetric Interleaved DC-DC Switching Converters: Generation, Modelling and Control",LAP Lambert Academic Publishing,Saarbrucken, Germany,2010.
- [9]. A.Nagoor Kani,"Control Systems",RBA Publications,Chennai,1998.
- [10]. Eliana Arango , Carlos Andres Ramos-Paja , Javier Calvente , Roberto Giral ,Sergio Serna ,," Asymmetrical Interleaved DC/DC Switching Converters forPhotovoltaic and Fuel Cell Applications— Part 1: CircuitGeneration, Analysis and Design, Energies 2012, 5, 4590-4623
- [11]. C. Garcia, P. Zumel, A. D. Castro, and J. A. Cobos, "Automotive DC–DC bidirectional converter made with many interleaved buck stages," IEEETrans. Power Electron., vol. 21, no. 21, pp. 578–586, May 2006.
- [12]. C. S.Moo, Y. J. Chen, H. L. Cheng, and Y. C. Hsieh, "Twin-buck converter with zero-voltage-transition," IEEE Trans. Ind. Electron., vol. 58, no. 6,pp. 2366–2371, Jun. 2011.
- [13]. K. Yao, M. Ye, M. Xu, and F. C. Lee, "Tapped-inductor buck converter for high-step-down DC–DC conversion," IEEE Trans. Power Electron.,vol. 20, no. 4, pp. 775–780, Jul. 2005