

Switching System Using Multiplexers for Analog Signals

Anish Jasti¹, Neel Nakra², Chaitali Pulkundwar³, Saurabh Kelkar⁴

^{1,2,3,4,5} *Electronics And Telecommunication Department, Fr.C.R.I.T. Vashi, Navi Mumbai, India*

Abstract: High quality analog signal processors often suffer from limitations with respect to flexibility while routing signals and saving set of configurations. While this is overcome in digital signal processors, the audio signal quality is different from that in analog processors. The objective of our project is to build a system that uses the best of both worlds. The nature of the audio signal is preserved in the analog domain and thus free of A/D D/A conversion losses while the switching and routing is accomplished using microcontrollers in the digital domain, thereby giving us the flexibility of digital circuits.

Keywords: Processor, Relays, analog multiplexers, routing, 4351.

I. INTRODUCTION

In analog signal processing, for connecting and using multiple effects in a single system, we need complex wiring and connections. Although, a DSP based digital unit reduces the wiring and the total hardware but dynamic digital signal processing systems that can emulate analog circuits and offer comparable quality are very expensive. Even though, they have their own benefits like saving and recalling configurations, ease of operations with a coherent and centralized interface that make them a preferable choice, they are a onetime investment that offer little or no options to upgrade or expand. On the other hand, in order to have a multi-effects unit in the analog domain, the user needs to purchase each effect unit separately and connect them using patch cables to create the desired chain of effects. However, this can be done over time which not only relieves the user from the burden of shelling out a substantial investment at once but also gives him the freedom to modify, debug and customize the chain of effects without compromising on the quality

As it can evidently be seen both the domains, analog or digital, have their unique set of features to offer and it's challenging to have all those feature from both the domains in a single system. We will be having analog domain and handling, programming of it in digital domain. With this we fulfill the idea of making the best system using analog and digital systems.

This project follows the idea of taking the best from both the worlds and building a hybrid analog-digital signal processor that can minimize the shortcomings of the existing analog and digital routing circuitries.

The project is a single controller unit with which the user can connect his own set of analog effect units and control the routing of the effects digitally. It has a digital user interface which simplifies and optimizes the operations for the user. The switching of the circuits is controlled by a microcontroller which can also be programmed by the user, giving him the liberty to configure and customize the chain. The user can save different combinations and settings as patches and recall the saved patches instantly. ...[1]

II. RELAYS

A relay is an electrically operated switch. Many relays use an electromagnet to mechanically operate a switch, but other operating principles are also used, such as solid-state relays. Relays are used where it is necessary to control a circuit by a separate low-power signal, or where several circuits must be controlled by one signal.

SPST – Single Pole Single Throw. These have two terminals which can be connected or disconnected. Including two for the coil, such a relay has four terminals in total. It is ambiguous whether the pole is normally open or normally closed. The terminology "SPNO" and "SPNC" is sometimes used to resolve the ambiguity.

SPDT – Single Pole Double Throw. A common terminal connects to either of two others. Including two for the coil, such a relay has five terminals in total.

DPST – Double Pole Single Throw. These have two pairs of terminals. Equivalent to two SPST switches or relays actuated by a single coil. Including two for the coil, such a relay has six terminals in total. The poles may be Form A or Form B (or one of each).

DPDT – Double Pole Double Throw. These have two rows of change-over terminals. Equivalent to two SPDT switches or relays actuated by a single coil. Such a relay has eight terminals, including the coil.

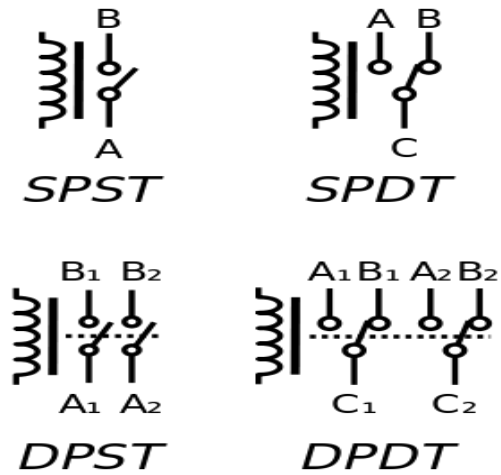

Fig.1 Types of switches

Switching System - Switches Network

Preliminary approach towards designing the switching system was using a SPDT and DPDT switches which can be implemented as shown in the diagram below.

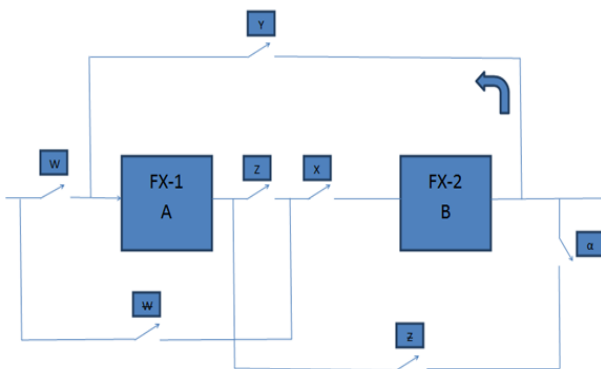

Fig.2 Routing Network using Switches

Here, two effects are used - FX1 and FX2. There are SPDTs W, Y, X, \overline{W} , Z, alpha. We can apply these two effects in parallel, series: FX1-FX2, FX2-FX1 or single effects. If we consider series effect FX2-FX1, initially W is open, \overline{W} , X is closed. Signal passes through FX2, Y closes and signal passes through FX1. This signal is then passed through Z. Similarly, other effects are implemented. The routing when 3 or more effects are used, more number of switches are used.

With more number of switches used the circuit becomes more complicated and routing becomes tedious. For switching networks other options have to be considered such as CMOS implementation or digital multiplexing networks.

III. ANALOG MULTIPLEXER

Multiplexers are mainly used to increase the amount of data that can be sent over the network within a certain amount of time and bandwidth. The multiplexing divides the capacity of the communication channel into several logical channels, one for each message signal or data stream to be transferred. An electronic multiplexer makes it possible for several signals to share one device resource. It solves the above problems of circuit switching.

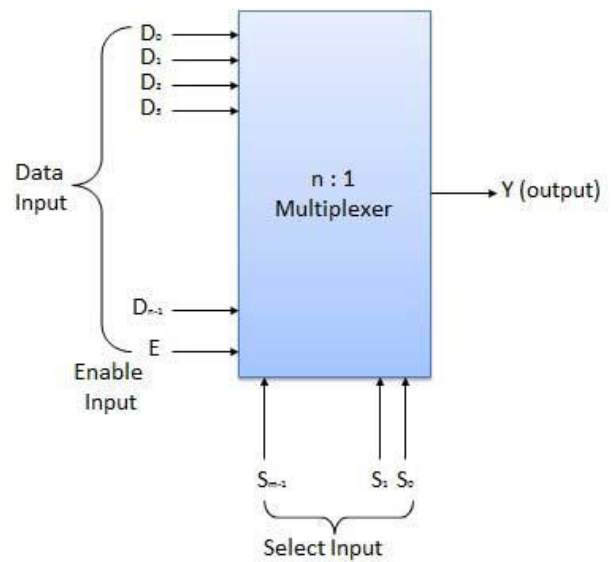

Fig.3 Multiplexer

IV. MULTIPLEXING NETWORK

The multiplexer approach uses multiplexers for routing the signals through multiple effects without signal distortions or any complications. This network has minimum number of 3 or audio effects can be used serially in any combination. For 3 effects there are 15 combinations possible for which the circuit is much simpler than above.

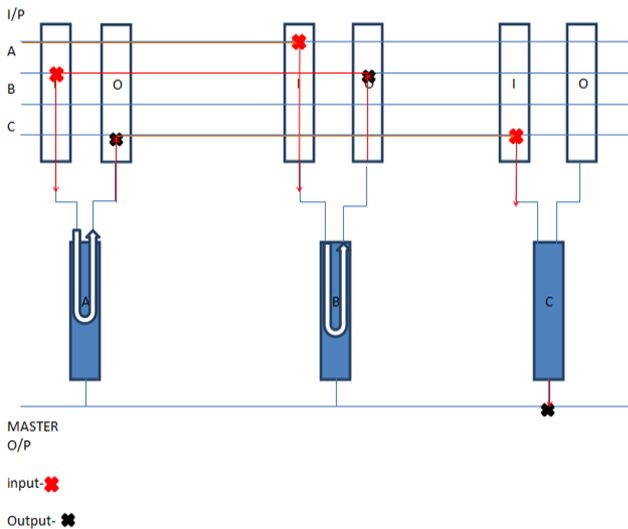

Fig.4 Switching Network using Multiplexer

Consider effect combination BAC. A,B,C in blue boxes are multiplexers of effects

FX1, FX2, FX3 respectively. There are 3 buses for these effects as well. Initially, the input guitar signal is put on bus B from where it passes through the effect and then is given on bus input of effect A. After passing through the effect A it passes on the bus C, effect C and output signal is obtained with BAC combination. For routing from one bus to another we can use SPDTs or digitally controlled signals.

V. MULTIPLEXERS OVER SWITCHES

- Circuit switching requires circuits and their associated state to be established before data can be transferred, increasing the complexity in the circuit.
- As the number of pedals increase, the number of switches also increase.
- The hardware cost associated with this is high.
- The addition of switches increases noise.
- Connection set-up delay: No communication until the connection is set up and also unable to avoid extra latency for small data transfers. This is not a good thing when frequencies change at minute intervals.

VI. IMPLEMENTATION

The routed network is fed with a user-defined combination of analog effects. The user interface is connected to and controlled by a microcontroller, Arduino in this case. The fed combination is read by the controller and the multiplexers are tuned accordingly. The multiplexers are governed by a set of 3 select lines.

The microcontroller will allot the channels to the respective multiplexers and the analog signal will be routed. Thus, the quality of the signal is conserved along with making controlling end user-friendly. The advantages of analog and digital systems go hand-in-hand in this system.

The system is also provided with an external memory/flash memory. The combinations of the effects specified by the user can thus be saved. These can be recalled further for future use.

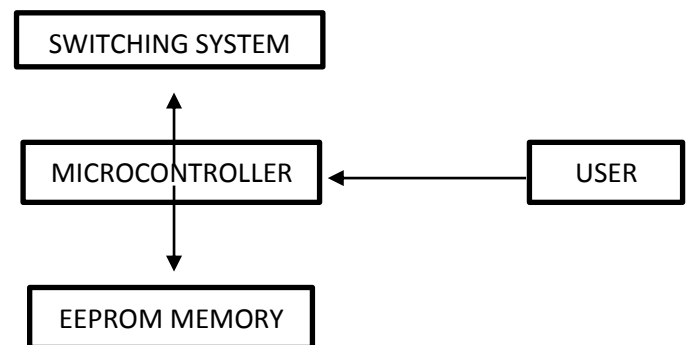

Fig.5 Block Diagram

VII. HARDWARE USED

ATmega 2560:

To do the routing digitally we are using ATmega 2560. It is the best option for handling the interfacing, multiplexers and EEPROM memory.

SPECIFICATIONS OF ATMEGA 2560:

Flash (kBytes):256 kBytes

Pin Count: 100

Max. Operating Freq. (MHz): 16 MHz

CPU: 8-bit AVR

Max I/O Pins: 86

The high-performance, low-power Atmel 8-bit AVR RISC-based microcontroller combines 8KB SRAM, 4KB EEPROM, 86 general purpose I/O lines, 32 general purpose working registers, real time counter, six flexible timer/counters with compare modes, PWM, 4 USARTs, byte oriented 2-wire serial interface, 16-channel 10-bit A/D converter, and a JTAG interface for on-chip debugging. The device achieves a throughput of 16 MIPS at 16 MHz and operates between 4.5-5.5 volts.

By executing powerful instructions in a single clock cycle, the device achieves a throughput approaching 1 MIPS per MHz, balancing power consumption and processing speed.....[2]

74HC4351 ANALOG MULTIPLEXER:

The 74HC/HCT4351 are 8-channel analog multiplexers/demultiplexers with three select inputs (S0 to S2), two enable inputs (E1 and E2), a latch enable input (LE), eight independent inputs/outputs (Y0 to Y7) and a common input/output (Z).

With E1 LOW and E2 is HIGH, one of the eight switches is selected (low impedance ON-state) by S0 to S2. The data at the select inputs may be latched by using the active LOW latch enable input (LE). When LE is HIGH the latch is transparent. When either of the two enable inputs, E1 (active LOW) and E2 (active HIGH), is inactive, all 8 analog switches are turned off.

VCC and GND are the supply voltage pins for the digital control inputs (S0 to S2, LE, E1 and E2). The VCC to GND ranges are 2.0 to 10.0 V for HC and 4.5 to 5.5 V for HCT. The analog inputs/outputs (Y0 to Y7, and Z) can swing between VCC as a positive limit and VEE as a negative limit. ...[3]

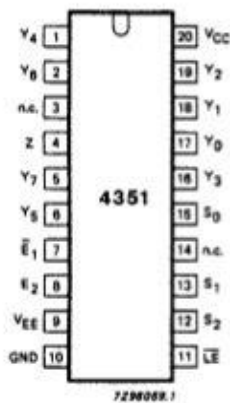

Fig.6 IC 74HCT4351 Pin Diagram

V. RESULT

The routing system has been successfully implemented and is working without any errors. There was some distortion and crosstalk in the unused channels of the multiplexer which was eventually reduced by referencing the channels. The multiplexers gave a voltage swing of 9V p-p in the routing system. On further increasing the input, the output through the multiplexer was clipped.

VI. SUMMARY AND FUTURE WORK

The implementation of this project will result in an optimized analog routing system. This system will find many applications in music signal processing, sound signal processing and biomedical. In the near future, applications of this routing system can be found out and implemented accordingly. The analog signal processing will no longer be a concern and can be achieved in a go.

Acknowledgment

We would like to thank Mrs. Sadhana Pai for the valuable guidance she provided for completing this in Fr. Conceicao Rodrigues Institute of Technology, Vashi which gave us opportunity to present our technical skills and enhance our knowledge.

REFERENCES

- [1] Signals by Ramani adapted from ME Angolette, CERN.
- [2] Arduino mega specifications [Online] Available: <https://www.arduino.cc/en/Main/ArduinoBoardMega>
- [3] 74HCT4351 datasheet [Online] Available: <http://www.nxp.com/74HCT4351>