

A Comparison of Half Bridge & Full Bridge Isolated DC-DC Converters for Electrolysis Application

R. Samuel Rajesh Babu, Joseph Henry

Abstract— This paper presents a comparison of half bridge and full bridge isolated, soft-switched, DC-DC converters for Electrolysis application. An electrolyser is a part of renewable energy system which generates hydrogen from water electrolysis that used in fuel cells. A DC-DC converter is required to couple electrolyser to system DC bus. The proposed DC-DC converter is realized in both full-bridge and half-bridge topology in order to achieve zero voltage switching for the power switches and to regulate the output voltage. Switching losses are reduced by zero voltage switching. Switching stresses are reduced by using resonant inductor and capacitor. The proposed DC-DC converter has advantages like high power density, low EMI, reduced switching stresses, high circuit efficiency and stable output voltage. The MATLAB simulation results show that the output of converter is free from the ripples and regulated output voltage and this type of converter can be used for electrolyser application. Experimental results are obtained from a MOSFET based DC-DC Converter with LC filter. The simulation results are verified with the experimental results.

Index Terms— DC-DC converter, electrolyser, renewable energy sources, resonant converter, TDR.

I. INTRODUCTION

Nowadays the energy conversion from renewable energy sources, such as wind turbine generators (WTGs) or photovoltaic (PV) arrays with suitable energy storage can play an important role in the development and operation of distributing energy source systems (stand alone or grid connected). In the recent years the technology development of the fuel cells energy storage systems allowed the use of the fuel cell as an alternative to the commonly used battery storage systems.

In distributed energy source applications electrolytic hydrogen offers a promising alternative for long-term energy storage of renewable energy. In this paper a distributed energy source is described and discussed focusing on the interaction among the several parts connected to the electrical DC bus [1]. A key role inside this technical environment is played by the machines used for the hydrogen production. In modern complex networks they are mainly used for the production of energy supplied by the grid itself or other renewable energy systems, such as PV plants. The main aim of this electrical

system is the hydrogen storage devoted to the suitable load supplying in order to obtain an optimum load profile in case of domestic consumers. The energy is supplied to the electrolyser or the storage system according to the load profile. The stored hydrogen is fed to a fuel cell to produce electricity. The main target of the analysis is the evaluation of a DC-DC converter topology that supplies the electrolyser in order to obtain the optimization of the converter efficiency [2]-[4].

The converter switches which have been used are super junction MOSFET's with reduced forward resistance in the conduction mode and improved dynamic characteristics in the switching transients [5]-[7]. The converter strategy control allows a zero voltage transient on the power switches of the full-bridge inverter.

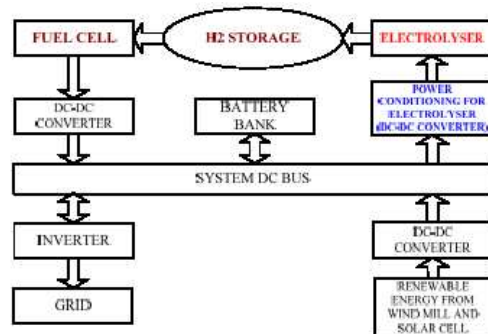

Fig 1. Block diagram of a typical renewable energy system

During periods when the renewable resources exceed the load demand, hydrogen would be generated and stored through water electrolysis [8]-[12]. For this purpose Electrolyser, which breaks water into hydrogen and oxygen is used as an integral part of RES in Fig. 1. During periods when the load demand exceeds the renewable resource input, a fuel cell operating on the stored hydrogen would provide the balance of power [13].

To ensure proper flow of power between the systems elements, the available energy from different sources are coupled to a low voltage DC bus [14]-[18]. A direct connection of DC bus to the Electrolyser is not suitable because it lacks the ability to control the power flow between the renewable input source and the Electrolyser. Therefore, a power conditioning system, usually a DC-DC converter is required to couple the Electrolyser to the system bus [19]-[22].

Manuscript received July 09, 2011.

R. Samuel Babu, Research Scholar, EEE Department, Sathyabama University, Chennai, India (e-mail: samuel.rajeshbabu@gmail.com).

Dr. Joseph Henry, EEE Department, Vel Tech University, Chennai, India.

A Comparison of Half Bridge & Full Bridge Isolated DC-DC Converters for Electrolysis Application

In order to understand the behavior of the electrolyser system and for the suitable design of the supply DC-DC converter, a characterization on an actual electrolyser has been carried out. The electrolyser is connected to the DC bus through a DC-DC power converter. During periods when the load demand exceeds the renewable resource input, a fuel cell operating on the stored hydrogen would provide the balance of power [23].

To ensure proper flow of power between the system elements, the available energy from different sources are coupled to a low voltage DC bus. A direct connection of DC bus to the electrolyser is not suitable because it lacks the ability to control the power flow between the renewable input source and the electrolyser.

Therefore, a power conditioning system, usually a DC-DC converter is required to couple the electrolyser to the system bus. High-frequency (HF) transformer isolated, HF switching dc-dc converters are suitable for this application due to their small size, light weight and reduced cost.

To increase their efficiency and to further increase the switching frequency while reducing the size, cost and EMI problems, soft-switching techniques will be used in this paper. Resonant converters offer low switching losses due to zero voltage switching (ZVS) making them popular for high frequency applications.

II. CIRCUIT TOPOLOGIES

1. Full-Bridge Topology
2. Half-Bridge Topology

III. ANALYSIS OF SELECTED CONVERTERS

The selected converters are designed for the worst operating conditions of: minimum input voltage, $V_{in} = 40$ V; maximum output voltage,

$V_o = 200$ V; and maximum output power (2 kW for each cell); switching frequency, $f_s = 20$ kHz; inverter output pulse-width, $\delta = \pi$.

A. Analysis of Half Bridge DC-DC Converter

The half bridge converter applies a square wave of voltage to a resonant network. The resonant network has the effect of filtering the higher harmonic voltages so that, essentially, a sine wave of current appears at the input to the resonant circuit (this is true over most of the load range of interest). This fact allows classical ac analysis techniques to be used.

The fundamental component of the square wave input voltage is applied to the resonant network, and the resulting sine waves of current and voltage in the resonant circuit are computed using classical AC analysis. For a rectifier with an inductor output filter, the sine wave voltage at the input to the rectifier is rectified, and the average value takes to arrive at the resulting dc output voltage.

For a capacitive output filter, a square wave of voltage appears at the input to the rectifier while a sine wave of current is injected into the rectifier. For this case the fundamental component of the square wave voltage is used in the ac analysis.

The even harmonics in the output of the rectifier are filtered using LC filter. Driving pulses are applied to the MOSFET in such a way that the pulse width coincides with the resonant.

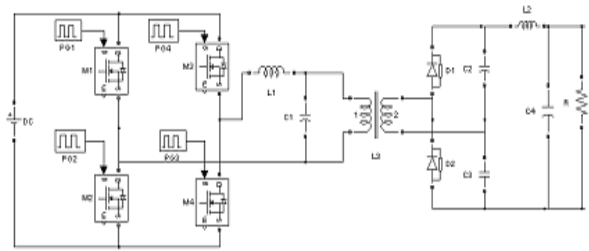

Fig 2. Half Bridge DC-DC Converter.

A. Analysis of full Bridge DC-DC Converter

The full bridge converter applies a square wave of voltage to a resonant network. The resonant network has the effect of filtering the higher harmonic voltages so that, essentially, a sine wave of current appears at the input to the resonant circuit (this is true over most of the loadrange of interest). This fact allows classical ac analysis techniques to be used.

The fundamental component of the square wave input voltage is applied to the resonant network, and the resulting sine waves of current and voltage in the resonant circuit are computed using classical AC analysis. For a rectifier with an inductor output filter, the sine wave voltage at the input to the rectifier is rectified, and the average value takes to arrive at the resulting dc output voltage. For a capacitive output filter, a square wave of voltage appears at the input to the rectifier while a sine wave of current is injected into the rectifier. For this case the fundamental component of the square wave voltage is used in the ac analysis.

The even harmonics in the output of the rectifier are filtered using LC filter. Driving pulses are applied to the MOSFET in such a way that the pulse width coincides with the resonant period.

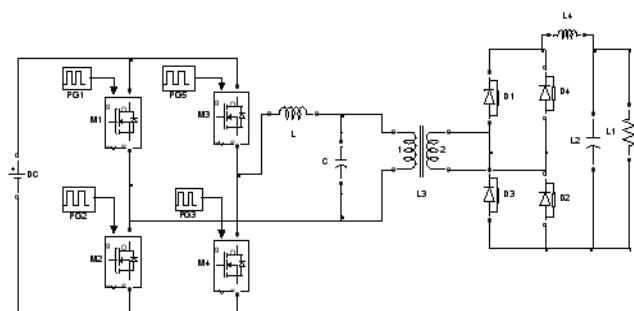

Fig 3. Full Bridge DC-DC Converter.

IV. SIMULATION RESULTS OF HALF BRIDGE CONVERTER SYSTEM

The simulation is done using Matlab simulink and results are presented. Scope is connected to display the output voltage.

V. SIMULATION RESULTS OF FULL BRIDGE DC-DC CONVERTER SYSTEM

The simulation is done using Matlab simulink and results are presented. Scope is connected to display the output voltage.

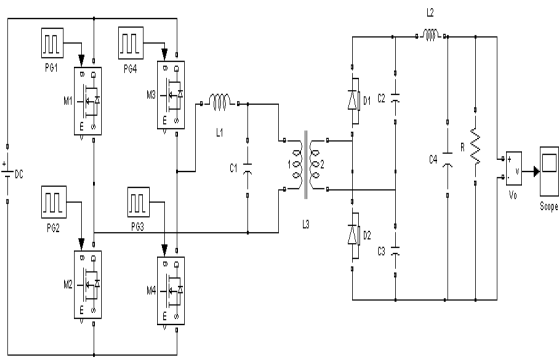

Fig 4 (a) Half Bridge DC-DC converter with LC filter

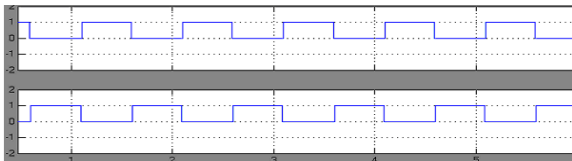

Fig 4 (b) Driving Pulses

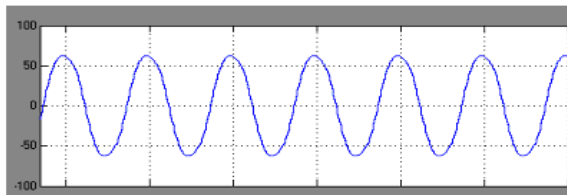

Fig 4 (c) Inverter output voltage with LC filter

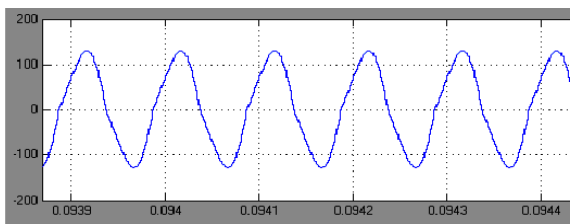

Fig 4 (d) Transformer secondary voltages

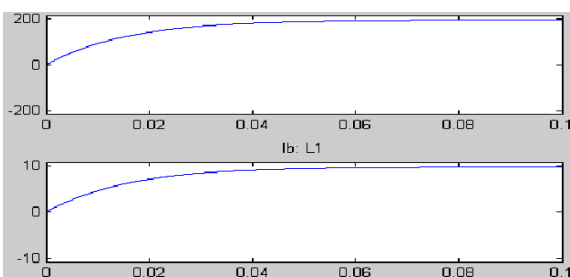

Fig 4 (e) Output voltage and current

Half Bridge DC-DC converter with LC filter is shown in Fig. 4(a). Driving pulses given to the MOSFET's M1, M3 & M2, M4 are shown in Fig. 4(b). Inverter output voltage with LC filter is shown in Fig. 4(c). Transformer secondary voltage is shown in Fig. 4(d). DC output voltage and current are shown in Fig. 4(e).

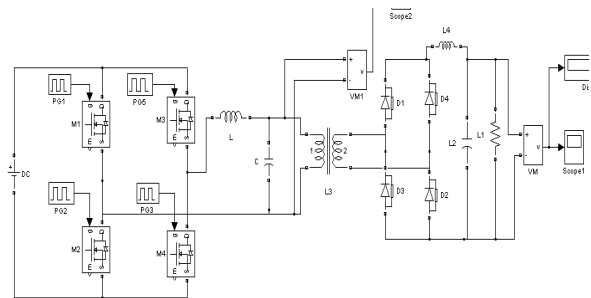

Fig 5 (a) Full Bridge DC-DC converter with LC filter

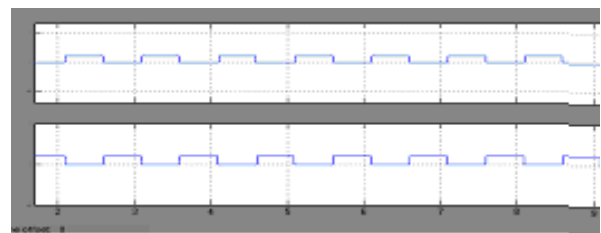

Fig 5 (b) Driving Pulses

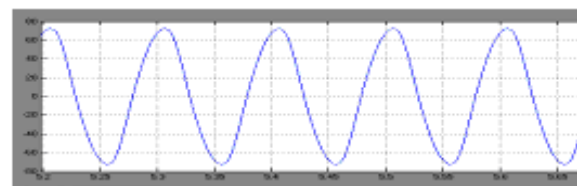

Fig 5 (c) Inverter output voltage with LC filter

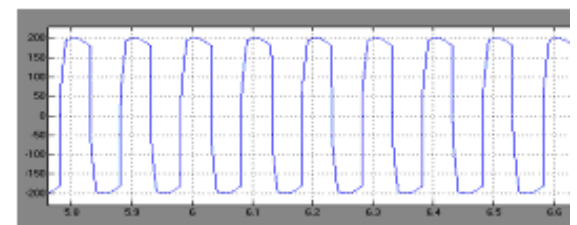

Fig 5 (d) Transformer secondary voltage

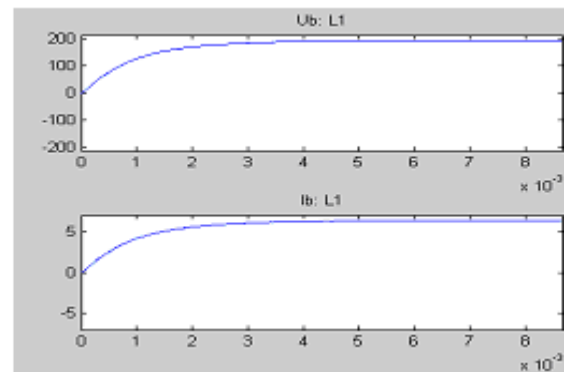

Fig 5 (e) Output voltage and current

Full Bridge DC-DC converter with LC filter is shown in Fig. 5(a). Driving pulses given to the MOSFET's M1, M3 & M2, M4 are shown in Fig. 5(b). Inverter output voltage with LC filter is shown in Fig. 5(c). Transformer secondary voltage

A Comparison of Half Bridge & Full Bridge Isolated DC-DC Converters for Electrolysis Application

is shown in Fig. 5(d). DC output voltage and current are shown in Fig. 5(e).

VI. COMPARISON OF FULL BRIDGE AND HALF BRIDGE

Each switching device in the full bridge is subject to a voltage stress equal to dc-input voltage (V_{dc}), and current stress is load current (I_{ac}). $TDR=4*P_a$ $P_a=Output\ power$ For the half bridge each switching device's voltage stress is equal to twice the dc-input voltage ($2V_{dc}$), and current stress is load current (I_{ac}).

$$TDR=4*P_a.$$

The total device rating is the same for the half bridge and full bridge for the same output power. Full-bridge topology uses four switches whereas Half-bridge topology uses two switches.

A. Input Voltage Vs Output Voltage

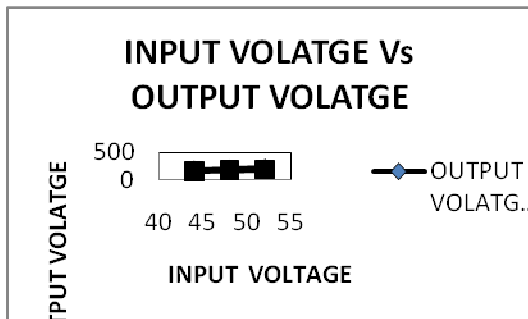

Fig 6 (a) Variation of Output voltage with Input voltage

INPUT VOLTAGE	OUTPUT VOLTAGE (HALF BRIDGE)	OUTPUT VOLTAGE (FULL BRIDGE)
44	180	158
48	196	172
52	212	182

A. Input Voltage Vs Output Power

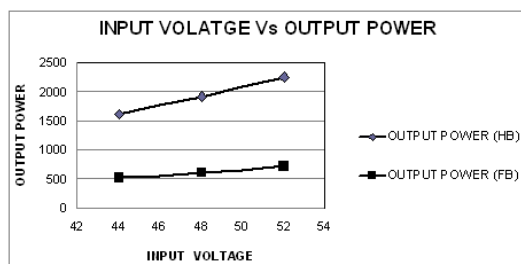

Fig 6 (b) Variation of Output powers with Input powers

INPUT VOLTAGE	OUTPUT POWER (HALF BRIDGE)	OUTPUT POWER (FULL BRIDGE)
44	1615	509
48	1923	606
52	2258	712

The variation of Output voltage with the variation in Input voltage is shown in Fig 6a. The variation of Output power

with the variation in Input power is shown in Fig 6b. It can be seen that half bridge converter gives higher power than that of full bridge converter. This is due to the dual rectifier system at the output.

VII. EXPERIMENTAL RESULTS OF HALF BRIDGE CONVERTER SYSTEM

The hardware is fabricated and tested in the laboratory with resistive load. Pulses required by the MOSFETs are generated by using a microcontroller. These pulses are amplified by using a driver amplifier. Hardware Layout is shown in Fig. 6a. AC input voltage is shown in Fig. 6b. Driving pulses are shown in Fig. 6c. Inverter output without filter is shown in Fig. 6d. Inverter output with filter is shown in Fig. 6e. DC output voltage is shown in Fig. 6f.



Fig. 6a – Hardware Layout

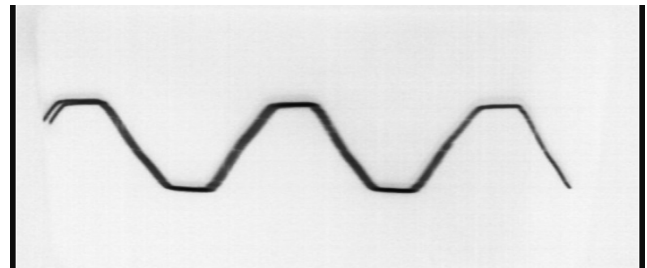

Fig. 6b - Ac input voltage

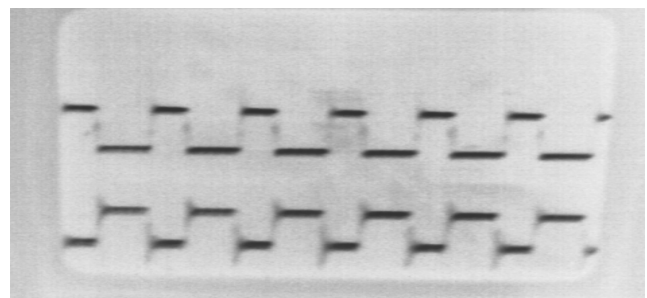

Fig. 6c - Driving pulses

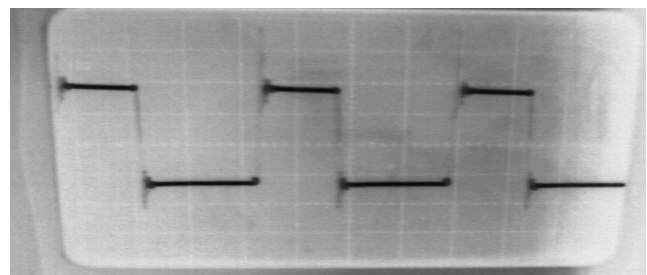

Fig. 6d - Inverter output voltage without filter

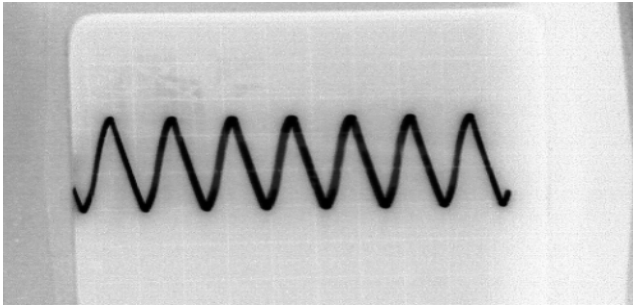

Fig. 6e - Inverter output voltage with filter

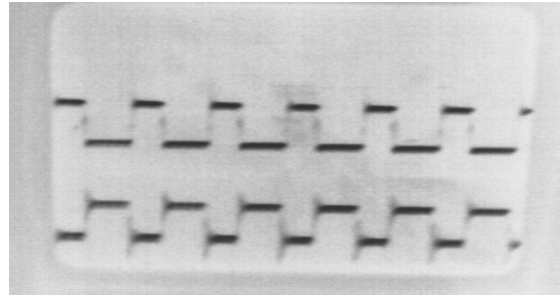

Fig. 7c - Driving pulses

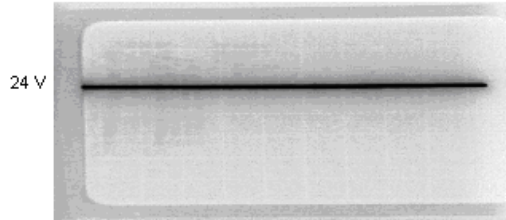

Fig. 6f - DC output voltage

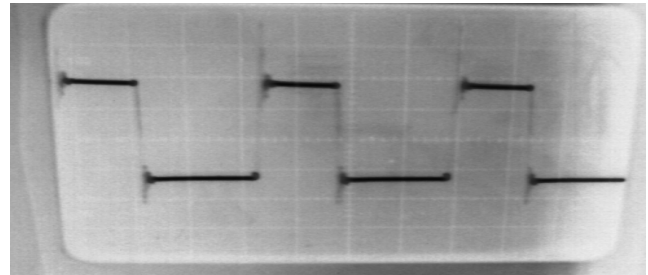

Fig. 7d - Inverter output voltage without filter

VIII. EXPERIMENTAL RESULTS OF FULL BRIDGE CONVERTER SYSTEM

The hardware is fabricated and tested in the laboratory with resistive load. Pulses required by the MOSFETs are generated by using a microcontroller. These pulses are amplified by using a driver amplifier. Hardware Layout is shown in Fig. 7a. AC input voltage is shown in Fig. 7b. Driving pulses are shown in Fig. 7c. Inverter output without filter is shown in Fig. 7d. Inverter output with filter is shown in Fig. 7e. DC output voltage is shown in Fig. 7f.

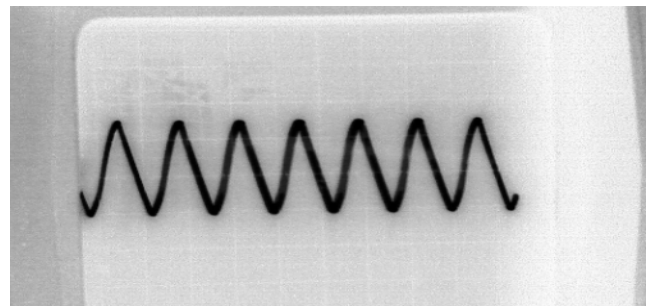

Fig. 7d - Inverter output voltage with filter

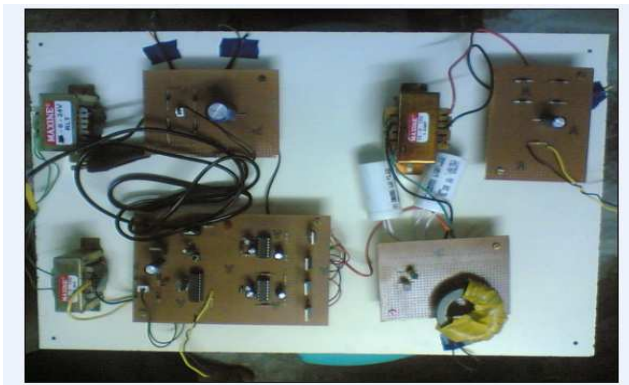

Fig. 7a - Hardware Layout

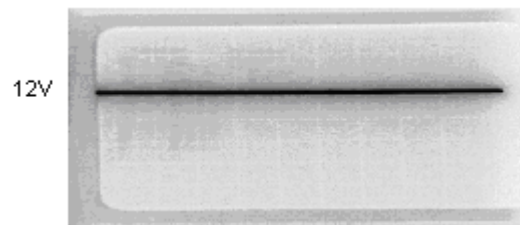

Fig. 7f - DC output voltage

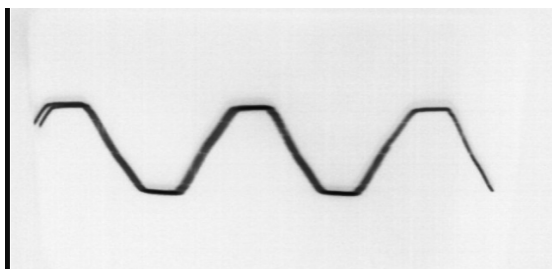

Fig. 7b - Ac input voltage

IX. CONCLUSION

A comparison of half bridge and full bridge isolated DC-DC converters for Electrolysis application are presented. DC-DC converters for electrolyser system is simulated and tested with LC filter at the output. The electrical performances of the converter have been analyzed. The simulation and experimental results indicate that the output of the inverter is nearly sinusoidal. The output of rectifier is pure DC due to the presence of LC filter at the output. Switching losses are reduced by zero voltage switching. Switching stresses are reduced by using resonant inductor and capacitor. The advantages of resonant converter are reduced (di/dt), low switching losses and high efficiency. Switching losses are reduced by zero voltage switching. Switching stresses are reduced by using resonant inductor and capacitor. The converter maximizes the efficiency through the zero voltage switching and the use of super-junction MOSFET as switching devices with high dynamic characteristics and low

direct voltage drop. Half bridge converter is found to be better than that of full bridge converter.

REFERENCES

- [1] E.J.Miller, "Resonant switching power conversion," in Power Electronics Specialists Conf.Rec., 1976, pp. 206-211.
- [2] V. Volperian and S. Cuk, "A complete DC analysis of the series resonant converter", in IEEE power electronics specialists conf. Rec. 1982, pp. 85-100.
- [3] R.L. Steigerwald, "High-Frequency Resonant Transistor DC-DC Converters", IEEE Trans. On Industrial Electronics, vol.31, no.2, May1984, pp. 181-191.
- [4] D.J. Shortt, W.T. Michael, R.L. Avert, and R.E. Palma, "A 600 W four stage phase-shifted parallel DC-DC converter," IEEE Power Electronics Specialists Conf., 1985, pp. 136-143.
- [5] V. Nguyen, J. Dhayanchand, and P. Thollot, "A multiphase topology series-resonant DC-DC converter," in Proceedings of Power Conversion International, 1985, pp. 45-53.
- [6] A.K.S. Bhat, "Analysis of resonant transistor DCDC converter with capacitive output filter," IEEE trans. on Ind. Electronics, vol. IE-32, pp.439-444, Nov. 1985.
- [7] R.L. Steigerwald, "A comparison of half-bridge resonant converter topologies," IEEE Trans. on Power Electronics, vol. 3, no. 2, April 1988, pp. 174-182.
- [8] F.S. Tsai, J. Sabate, and F.C. Lee, "Constant-frequency, zero-voltageswitched, clamped-mode parallel-resonant converter," IEEE International Energy Conference, 1989, paper # 16.4, pp. 1-7.
- [9] A.K.S. Bhat, "Fixed frequency PWM series-parallel resonant converter," IEEE Industry Applications Society Annual Meeting, vol. 1, October 1989, pp. 1115-1121.
- [10] F.S. Tsai, J. Sabate, and F.C. Lee, "Constant- Frequency, zero-voltageswitched, clamped-mode Parallel-resonant converter," IEEE International Energy Conference, 1989, paper # 16.4, pp. 1-7.
- [11] J. A. Sabate, V. Vlatkovic, R.B. Ridley, F.C. Lee and B.H. Cho, "Design considerations for high voltage, high power, full-bridge ZVS PWM converters," IEEE Applied Power Electronics Conf., 1990, pp. 275-284.
- [12] J.A. Sabate, and F.C. Lee, "Off-line application of the fixed-frequency clamped-mode series resonant converter," IEEE Trans. on Power Electronics, vol. 1, no. 1, January 1991, pp. 39-47.
- [13] R. Streit and D. Tollik, "High efficiency telecom rectifier using a novel soft-switched boost based input current shaper", IEEE INTELCO Conf. Record, 1991, pp.720-726.
- [14] A.K.S. Bhat, "Analysis and design of LCL-type resonant converter", IEEE Tran. On Industrial Electronics, vol.41, no.1, pp.118-124, Feb.1994.
- [15] A.K.S. Bhat, "Analysis and design of LCL-type resonant converter", IEEE Trans. on Industrial Electronics, vol. 41, no. 1, pp. 118-124, Feb. 1994.
- [16] A.K.S. Bhat, "Analysis and design of a fixed frequency LCL-type series resonant converter," IEEE Trans. on Aerospace and Electronic Systems, vol. 31, no. 1, Jan. 1995, 125-137.
- [17] H. Bodur and A. F. Bakan, "A new ZVT-PWM DC-DC converter," IEEE Trans. On Power Electr., vol.17, no.1, Jan. 2002, pp.40- 47.
- [18] A. K. S. Bhat, and F. Luo, "A new gating scheme controlled softswitching DC-DC bridge converter," IEEE Power Electronics and Drive Systems Conf. Record, 2003, pp. 8-15.
- [19] D. S. Gautam, "Soft-Switched DC-DC Converters for Power Conditioning of electrolyser in a Renewable Energy System," M.A.Sc Thesis, Dept. of ECE, University of Victoria, 2006.
- [20] D.S. Gautam and A.K.S. Bhat, "A comparison of soft-switched DC-DC converters for Electrolyser application", IEEE IICPE Conf. Record CD, Chennai, 2006.
- [21] Deepak S.Gautam and Ashoka K.S.Bhat, "A Comparison of Soft-switched DC-DC Converters for ElectrolyserApplications" proceedings of India International Conference on power electronics 2006



R. Samuel Rajesh Babu has obtained his B.E degree from Madras University in 2003. He has obtained his M.E degree from Anna University in 2005. Presently he is doing his research at Sathyabama University. His area of interests is DC - DC converters.



Dr. Joseph Henry has obtained his B.E Degree from Madras University in 1960. He obtained his M.E degree from IIT-Bombay in 1964. He obtained his Ph.D degree from IIT Delhi in 1978. Presently he is a professor in Vel Tech University. His areas of interest are Power Electronics and Digital Protection