

Experimental and Comparison Studies on Drying Characteristics of Tomatoes in a Solar Tunnel Greenhouse Dryer Coupled with and without Biomass Backup Heater

S. Arun, N. Yashwanth, R. Adharsh

Abstract— A natural convection solar tunnel greenhouse dryer coupled with biomass heater was designed and developed in Nallampalli region of Pollachi, Tamil Nadu (India) and also a natural convection solar tunnel greenhouse dryer without biomass heater was designed and developed in Negamam region of Pollachi, Tamil Nadu (India) for carrying out the experimental and comparison studies of drying characteristics of tomatoes during the month of May, 2014. About 50kgs of fresh and good quality tomatoes were loaded into those two respective dryers and it was repeated for three trails. The mass of fuel added to the biomass heater was about 7.5kg/hr. The biomass heater was ignited when there is a fall in sunshine (after 5PM) in order to maintain the temperature inside the dryer. The solar tunnel dryer coupled with the biomass heater dried the tomatoes which has an initial moisture content of 90% (w.b.) to a final moisture content of 9.5% (w.b.) over a time period of 24 hours whereas the solar tunnel greenhouse dryer without the biomass heater took 49 hours for reducing the moisture content of the tomatoes to the same level. The reduced drying time in the solar tunnel greenhouse dryer coupled with the biomass heater than that of the dryer without the biomass heater is due to the effect of biomass heater that is responsible for the steady increase in temperature inside the dryer by supplying sufficient heat during the night time (after 5PM) where there would be a drop in sunshine. Also the quality of the tomatoes obtained from the solar tunnel greenhouse dryer coupled with biomass heater was found to be superior to that of the tomatoes obtained from the solar tunnel greenhouse dryer without the biomass heater which is due to the high temperature and low relative humidity prevailed all the time inside the dryer irrespective of fall in sunshine.

Index Terms—Biomass heater, drying time, moisture content, open sun drying, quality, solar tunnel greenhouse dryer, sunshine, temperature.

I. INTRODUCTION

Tomato is the world's most commercially produced vegetable. Tomato is considered among seven major vegetables in the world, (onion, garlic, cauliflower, green peas, cabbage, tomato and green beans. It is a rich source of minerals, vitamins, organic acid, and dietary fiber. Global tomato production reached 146 million tons in 2011, according to FAOSTAT, and therefore considered the most

Manuscript Received on October 2014.

S. Arun, Mechanical Engineering, Dr. Mahalingam College of Engineering and Technology, Pollachi, India.

N. Yashwanth, Mechanical Engineering, Easwari Engineering College, Chennai, India.

R. Adharsh, Mechanical Engineering, Dr. Mahalingam College of Engineering and Technology, Pollachi, India.

important vegetable grown in the world. Tomatoes are rich in photochemical lycopene, which is a powerful antioxidant. Tomatoes help in the prevention of cardio-vascular disease and enhance cancer-fighting abilities. Tomato is one of the most profitable cash crops grown among Indian small scale farmers. The average consumption pattern of tomatoes in Indian diet is very high as they form an integral ingredient of ethnic cultural cuisine. Since tomato is highly perishable in the fresh state, it will leads to wastage and losses during the harvesting period. The prevention of the losses and wastage is of major interest especially when there is a subsequent imbalance in supply and demand at the harvesting off-season. Most of the agricultural products contain the highest moisture content of 25-80% which is unable for long preservation. Because of this high moisture content, the quality of the product is degraded by bacterial and fungal infections over the products. The most common method that is still practiced from the ancient times to avoid the spoilage of food stuffs is drying of products. Drying is an energy intensive operation which involves the removal of moisture content from the products to a certain level where there will be no effect of bacterial and fungal infections. In order to safe storage the tomatoes, the moisture content of the tomatoes should be reduced from 90% (w.b.) to 9.5% (w.b.). But, it requires a skilled person to carry out the process safely and effectively. The process of drying is done as the traditional open sun drying method where the products will be spread over the wider drying yard that is made of cement or sand. However, this process was found to be a time consuming process since the rate of removal of moisture content from the products will be slower as the surrounding atmospheric temperature and relative humidity are low and high respectively. Also, there will be deterioration in quality of the products since it would be infected by fungus and bacteria, contamination by insects, damage by animals and birds and windborne problems as a result of low atmospheric temperature and high relative humidity. Ultimately, the products cannot reach the high value market standards and the small scale farmers cannot meet profit. The traders, hence, would not buy these low quality products at a higher price that would be profitable to the farmers. To overcome the practical difficulties of open sun drying, a natural convection solar tunnel greenhouse dryer was designed and constructed in Negamam village of Pollachi, Tamil Nadu, India. It operates on the principle of solar tunnel greenhouse dryer in which all the solar radiations will be absorbed by the parabolic shaped dryer that is made of

polyethylene sheet. This sheet enhances the greenhouse effect and thus the absorbed radiations will not be emitted back to the atmosphere from the dryer thereby acting as a solar trap. This solar trapping of radiations is responsible for the temperature increase in the dryer than the open sun drying method thereby drying the products at an earlier than the OSD method. Moreover, this dryer overcomes the effect of bacterial and fungal infections, contamination by insects and other factors which degrades the quality of the dried products. But in this dryer also, there arises a problem when there is a fall in sunshine (after 5PM) which affects the drying of products in terms of drying time and intermittent drying. To overcome this problem, a natural convection solar tunnel greenhouse dryer coupled with biomass heater was designed and developed in Nallampalli region of Pollachi-Tamil Nadu, India. This dryer also works on the principle of greenhouse effect but the only difference from the former dryer is, the biomass heater coupled to this dryer. This biomass heater is able to supply sufficient heat to the dryer after 5PM (where there would be a fall in sunshine) to continue effective drying without any break in the drying of products. The biomass heater can be ignited with any type of fuel, normally, with the remains of coconuts such as coconut fronts, coconut shell, coconut husk and firewood. The biomass heater should be loaded with fuel for every one hour after 5PM of one day to 8 AM of the next day.

This study was undertaken to experimentally study and compare the drying characteristics of tomatoes in solar tunnel dryer coupled with and without the biomass heater and in the open sun drying method. Also, this study was to find out the best drying method for the effective drying of grapes and to compare the quality of the dried products.

II. EXPERIMENTAL SECTION

Experiments were carried out under meteorological conditions of Pollachi (latitude, 10.39°N; longitude, 77.03°E) in India during the month of March, 2014. On the basis of measurement, sunshine duration at this location was measured to be about 11 h per day. However, potential sunshine duration is only 8 h per day (9.00 am- 5.00 pm) based on higher solar intensity.

III. SOLAR TUNNEL GREENHOUSE DRYER (STD)

An STD (Fig.1) as a community model solar tunnel greenhouse drier [4 m (W) x 10 m (L) x 3 m (H) at centre] was designed and constructed at Negamam village using locally available materials. Semicircular portion of drier was covered with UV (200 μ) stabilized polyethylene film. No post was used inside the greenhouse, allowing a better use of inside space. Three exhaust vents with adjustable butterfly valves were provided at roof top. Inside drier, cement flooring was coated with black paint to improve its performance.

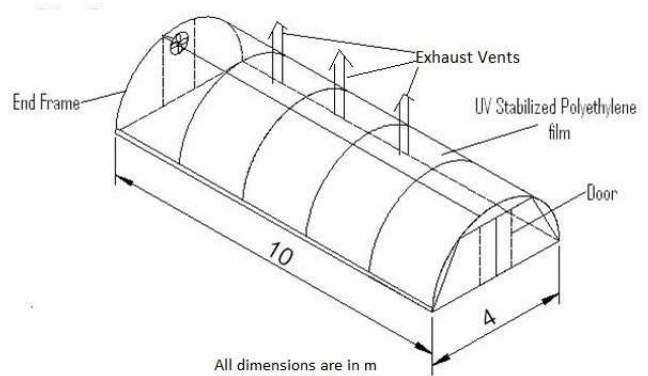

Fig. 1 Solar tunnel greenhouse dryer

STD is provided with metallic racks for keeping the products in layers for drying. To investigate the influence of parameters affecting the performance of solar tunnel drier, various measuring devices were installed. A pyranometer was used to measure the incident solar radiation falling on the roof of the solar tunnel greenhouse dryer. Thermocouples were used to measure air temperature at four different points inside the dryer and ambient air. To measure the relative humidity of the air, a hygrometer was employed. The electric signals from the thermocouples and the pyranometer were recorded with an 8-channel data logger. A sling psychrometer was also used to measure the dry bulb temperature and wet bulb temperature of the air.

IV. SOLAR TUNNEL GREENHOUSE DRYER COUPLED WITH BIOMASS BACKUP HEATER

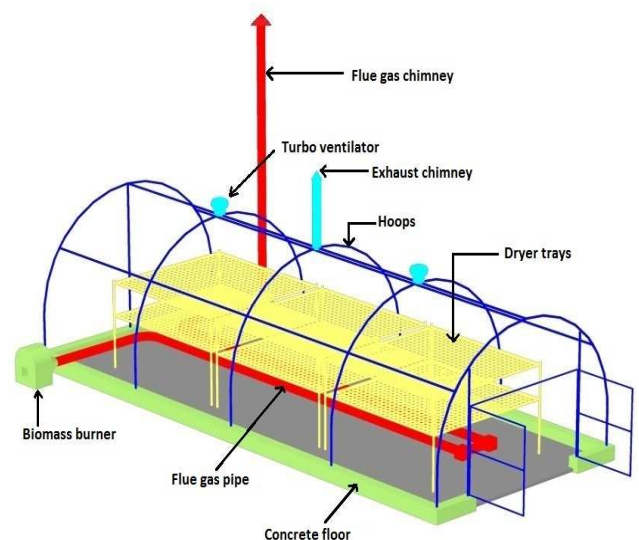

Fig. 2 Solar tunnel greenhouse dryer coupled with biomass backup heater

An STD (Fig.2) as a community model solar tunnel greenhouse drier [4 m (W) x 10 m (L) x 3 m (H) at centre] was designed and constructed at Nallampalli village using locally available materials. Both this dryer and the above mentioned dryer works on the principle of greenhouse effect. The only difference from the previous dryer (Fig.1) is that the biomass backup heater coupled to this dryer. The biomass heater can be ignited by any type of fuel such as coconut fronts, coconut shell and coconut husk. The biomass heater should be loaded

for every one hour interval so as to provide sufficient heat inside the dryer through the flue gas pipe that runs through the dryer. The flue gas pipes are there to radiate heat to the dryer thereby providing heat to it for the effective drying even at night time and rainy days.

V. INSTRUMENTATION

Figures Calibrated thermocouples (8 numbers, PT 100, uncertainty $\pm 1\%$) were fixed at different locations inside drier to measure air temperature. Humidity sensors (4 numbers, uncertainty $\pm 1\%$) were placed at different locations inside drier for measuring air humidity. Ambient humidity was calculated based on measured values of wet and dry bulb temperatures, using two calibrated thermometers, one covered with wet cloth. A solar intensity meter (Delta Ohm, Italy; uncertainty, $\pm 10\%$) was used to measure instantaneous solar radiation. All temperature sensors, humidity sensors and solar intensity meter were connected to a computer through a data logger (Simex, Italy). Air velocity at drier exit was measured by using a vane type thermo-anemometer (Equinox, Germany; uncertainty $\pm 0.1\%$) was used for weighing samples.

VI. PRINCIPLE OF SOLAR TUNNEL GREENHOUSE DRYER WITH AND WITHOUT BIOMASS HEATER

The solar radiation is transmitted into the drying chamber by the UV stabilized polyethylene film which provides the greenhouse effect. This film allows all the outside solar radiations to pass into the drying chamber and prevent the re radiation from the drying chamber to the outside and there by helps to accumulating the heat inside the drying chamber. Therefore, the temperature inside the drier is always more than the ambient temperature. This will helps to remove the moisture content of the product placed inside the dryer and therefore it gets dried.

VII. EXPERIMENTAL PROCEDURE

Experiments were conducted during 1-3rd and 27-29th of May, 2014 for the driers placed at Negamam and Nallampalli village of Pollachi, Tamil Nadu (India) respectively. Fresh and good quality tomatoes were cut into slices and then loaded in the respective dryers. Initial moisture content was calculated by taking 10 different samples from different locations inside the drier. Sliced tomatoes were loaded over trays (having 90% porosity) of drier unit. Then, the exhaust vents were opened to exhaust initial high humid air. Solar intensity, ambient temperature, dryer temperature and air velocity were measured every 1 h interval till end of drying. During night time (i.e.) in the absence of sun (after 5 PM), to maintain the temperature inside the dryer, biomass such as coconut fronds, coconut husk, coconut shell etc. have been added as a fuel to the biomass heater so as to give heat to solar tunnel dryer. Mass of the fuel added was about 7.5kg/hr and was added for every one hour interval from 5PM (previous day) to 8AM (next day).

VIII. DATA ANALYSIS

A. Determination of Moisture Content

About 10 g samples were chopped from randomly selected five cups and kept in a convective electrical oven, maintained at $105 \pm 1^\circ\text{C}$ for 5 hrs. Initial (m_i) and final mass (m_f) at time (t) of samples were recorded using electronic balance and repeated every 1 h interval till the end of drying. Moisture content on wet basis (M_{wb}) is defined as

$$M_{wb} = (m_i - m_f) / m_i$$

where, m_i and m_f are initial and final weight of samples respectively.

IX. RESULTS AND DISCUSSIONS

B. Variation of temperature with time

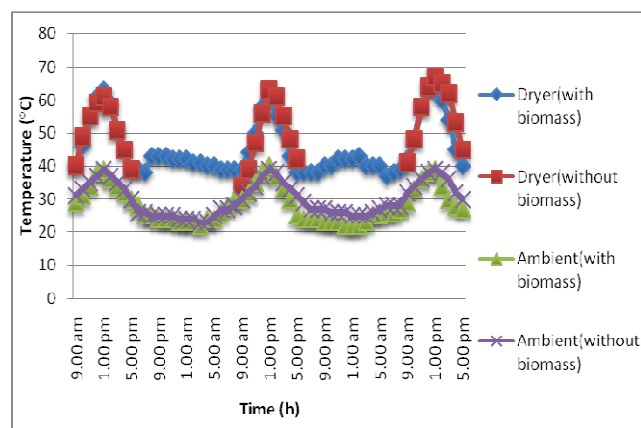

Fig. 3 Variation of temperature with time

The fig.3 shows the variation of ambient temperature and dryer temperature with and without biomass backup heater over time during the experimental period for the drying of tomatoes in Pollachi region. During the first 24 hours of the experiment (first day) in the dryer that is coupled with the biomass heater, the temperature inside the dryer varied between 40°C and 63°C with a peak value of 63°C at around 1.00 p.m. , the ambient temperature varied between 22°C and 39°C with a peak value of 39°C at around 1.00 p.m. whereas for the dryer without the biomass heater, the temperature inside the dryer varied between 39°C and 61°C with a peak value of 61°C at around 1.00p.m., the ambient temperature varied between 31°C and 39°C with a peak value of 39°C at around 1.00 p.m. During the next 24 hours of the experiment (second day) in the drier that is coupled with the biomass heater, the temperature inside the dryer varied between 38°C and 61°C with a peak value of 61°C at around 1.00 p.m. , the ambient temperature varied between 22°C and 40°C with a peak value of 40°C at around 1.00 p.m. whereas for the dryer without the biomass heater, the temperature inside the dryer varied between 34°C and 63°C with a peak value of 63°C at around 1.00p.m., the ambient temperature varied between 30°C and 37°C with a peak value of 37°C at around 1.00 p.m. During the last 24 hours of the experiment (third day) in the dryer that is coupled with the biomass heater, the temperature inside the dryer varied between 40°C and 64°C with a peak value of 64°C at around 1.00 p.m. , the ambient temperature varied between 22°C and 39°C with a peak value of 39°C at around 1.00 p.m. whereas for the dryer without the biomass heater, the temperature inside the dryer varied between 41°C and 67°C with a peak value of 67°C at around 1.00p.m., the

ambient temperature varied between 32°C and 38°C with a peak value of 38°C at around 1.00 p.m. It is clear from the figure that the temperature inside the dryer that is coupled with the biomass heater was 4°C to 6°C more than the temperature inside the dryer without the biomass heater in all the three days of the experimental period. It is evident that the tomatoes dried at an earlier time in the dryer coupled with the biomass heater than the dryer that is without the biomass heater which is due to the high temperature prevailed all the time inside the former dryer as a result of biomass heater. It also reveals that there was a steady increase in temperature in the dryer that is coupled with the biomass heater even at low sunshine period and night time which is due to the effect of biomass heater coupled to the dryer. This steady increase in temperature is responsible for the drying of tomatoes at an earlier time than the dryer without the biomass heater and the open sun drying method.

C. Variation of relative humidity with time

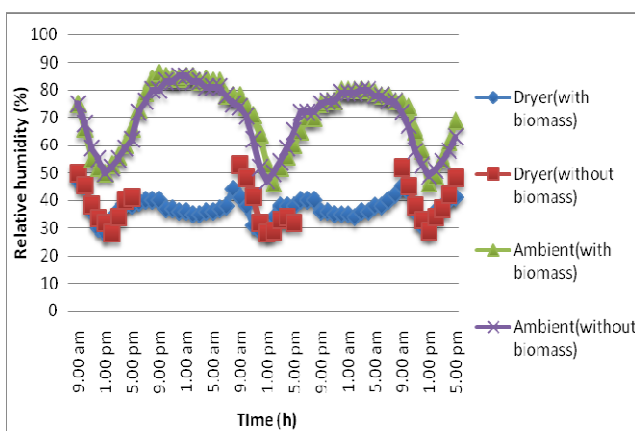

Fig. 4 Variation of relative humidity with time

The fig.4 shows the variation of relative humidity of the dryer with and without biomass heater over time during the experimental period. During the first 24 hours of the experiment (first day) in the dryer that is coupled with biomass heater, the relative humidity of the dryer varied between 28% and 47%, the ambient relative humidity varied between 50% and 86% whereas for the dryer without the biomass heater, the relative humidity varied between 28% and 50%, the ambient relative humidity varied between 50% and 85%. During the next 24 hours of the experiment (second day) in the dryer that is coupled with biomass heater, the relative humidity of the dryer varied between 28% and 41%, the ambient relative humidity varied between 46% and 80% whereas for the dryer without the biomass heater, the relative humidity varied between 28% and 53%, the ambient relative humidity varied between 47% and 80%. During the last 24 hours of the experiment (third day) in the dryer that is coupled with the biomass heater, the relative humidity of the dryer varied between 28.5% and 45%, the ambient relative humidity varied between 46% and 86% whereas for the dryer without the biomass heater, the relative humidity varied between 29% and 52%, the ambient relative humidity varied between 46% and 86%. From the fig.4, it is clear that the relative humidity of the dryer that is coupled with the biomass heater was less when compared with the relative humidity of the dryer without the biomass heater which is primarily due to the effect of biomass heater that is responsible for the prevailing of high temperature inside the dryer all the time

even at night time. This high temperature and low relative humidity that prevailed all the time inside the dryer (with biomass heater), dried the tomatoes at a quicker time than the dryer without biomass heater and the open sun drying method.

D. Variation of velocity with time

The fig.5 shows the variations of ambient velocity and the velocities of the dryer with biomass and without biomass heater over time during the experimental period. During the first 24 hours of the experiment (first day) in the dryer that is coupled with the biomass heater, the velocity of air inside the dryer varied between 0.1 m/s and 2.5 m/s and the ambient air velocity varied between 1.7 m/s and 3.5 m/s whereas for the dryer without the biomass heater, air velocity varied between 1 m/s and 1.4 m/s and the ambient air velocity varied between 1.6 m/s and 2.8 m/s. During the next 24 hours of the experiment (second day) in the dryer that is coupled with the biomass heater, the velocity of air inside the dryer varied between 0.1 m/s and 2.4 m/s and the ambient air velocity varied between 0.9 m/s and 2.3 m/s whereas for the dryer without the biomass heater, air velocity varied between 1.2 m/s and 2 m/s and the ambient air velocity varied between 1.9 m/s and 3.2 m/s. During the last 24 hours of the experiment (third day) in the dryer that is coupled with the biomass heater, the velocity of air inside the dryer varied between 1.1 m/s and 2.5 m/s and the ambient air velocity varied between 1.5 m/s and 2.9 m/s whereas for the dryer without the biomass heater, air velocity varied between 1 m/s and 1.6 m/s and the ambient air velocity varied between 1.8 m/s and 3.2 m/s. It can be clearly seen that the air velocity inside the dryer that is coupled with the biomass heater was more than the air velocity inside the dryer that is without the biomass heater which is due to the high temperature prevailed all the time inside the dryer (with biomass heater) even during the night time. This increase in air velocity makes the products (Tomatoes) to dry at an earlier time than the open sun drying method and the dryer without the biomass heater.

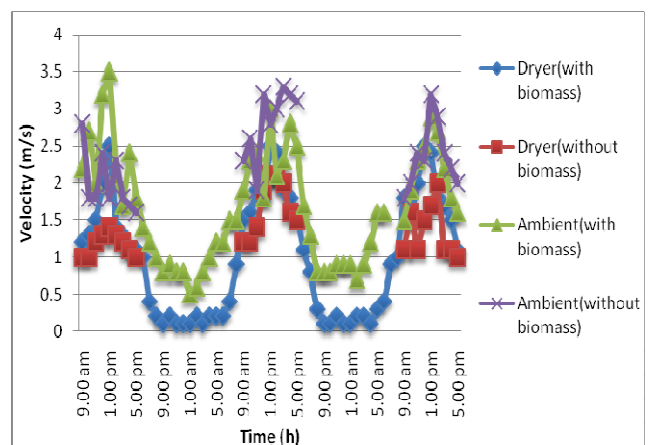

Fig. 5 Variation of velocity with time

E. Variation of sheet temperature with time

The fig.6 shows the variations of sheet temperature inside and outside the dryer (with and without biomass heater) over time during the experimental period. During the first 24 hours of the experiment (first day), the sheet temperature inside the dryer varied from 40°C and 65°C, the sheet temperature outside the dryer varied from 23°C and 40°C whereas for the dryer without the biomass heater, the sheet temperature inside

the dryer varied from 40°C and 62°C, the sheet temperature outside the dryer varied from 31°C and 39°C. During the next 24 hours of the experiment (second day), the sheet temperature inside the dryer varied from 39°C and 65°C, the sheet temperature outside the dryer varied from 23°C and 41°C whereas for the dryer without the biomass heater, the sheet temperature inside the dryer varied from 35°C and 63°C, the sheet temperature outside the dryer varied from 30°C and 38°C.

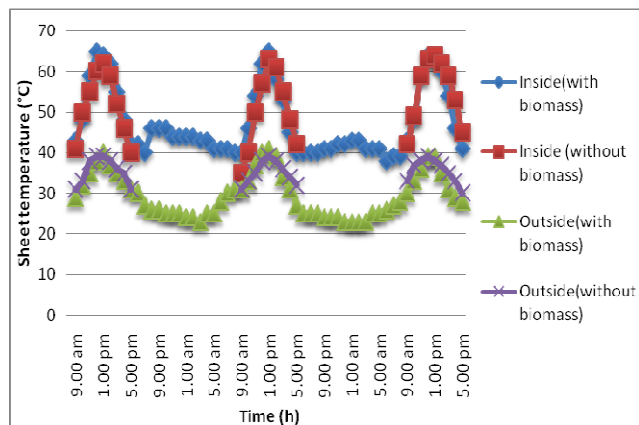

Fig. 6 Variation of sheet temperature with time

During the last 24 hours of the experiment (third day), the sheet temperature inside the dryer varied from 37°C and 64°C, the sheet temperature outside the dryer varied from 23°C and 39°C whereas for the dryer without the biomass heater, the sheet temperature inside the dryer varied from 42°C and 64°C, the sheet temperature outside the dryer varied from 30°C and 39°C. It is evident that the sheet temperature inside the dryer that is coupled with the biomass heater was more than the sheet temperature inside the dryer without the biomass heater which is due to the effect of biomass heater coupled to the dryer. This biomass heater maintained the high temperature inside the dryer all the time even after 5PM which paved the path for the quicker drying of tomatoes inside the dryer (with biomass heater) than the dryer without the biomass heater and the open sun drying method.

F. Variation of floor temperature with time

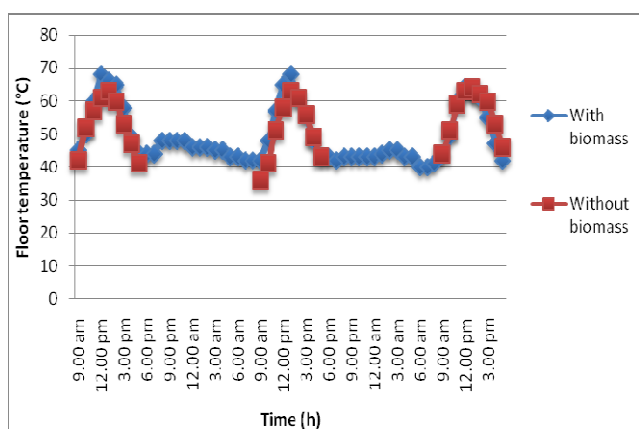

Fig. 7 Variation of floor temperature with time

The fig.7 shows the variation of floor temperature of the dryer with and without the biomass heater over time during the experimental period. During the first 24 hours of the experiment (first day) in the dryer that is coupled with the

biomass heater, the temperature of the floor inside the dryer varied from 44°C and 68°C whereas for the dryer without the biomass heater, the temperature of the floor inside the dryer varied from 41°C and 63°C. During the next 24 hours of the experiment (second day) in the dryer that is coupled with the biomass heater, the temperature of the floor inside the dryer varied from 40°C and 67°C whereas for the dryer without the biomass heater, the temperature of the floor inside the dryer varied from 36°C and 63°C. During the last 24 hours of the experiment (third day) in the dryer that is coupled with the biomass heater, the temperature of the floor inside the dryer varied from 38°C and 64°C whereas for the dryer without the biomass heater, the temperature of the floor inside the dryer varied from 44°C and 64°C. From the figure, it is clear that the floor temperature of the dryer that is coupled with the biomass heater is more than the floor temperature of the dryer without the biomass heater which is primarily due to the effect of biomass heater that steadily increased the temperature inside the dryer even after the fall in sunshine (after 5PM). Thus, this is also the reason for the reduced drying time inside the dryer (with biomass heater) than that of the open sun drying method and the dryer without biomass heater.

G. Variation of product temperature with time

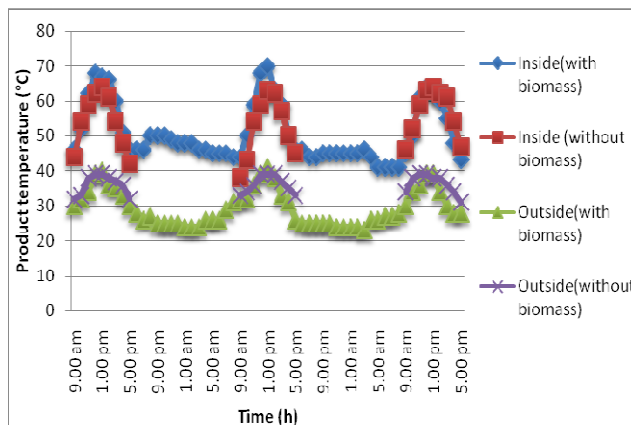

Fig. 8 Variation of product temperature with time

The fig.8 shows the variation of product temperature inside and outside the dryer (with biomass and biomass heater) over time during the experimental period. During the first 24 hours of the experiment (first day), the product temperature inside the dryer varied from 46°C and 68°C, the product temperature outside the dryer varied from 24°C and 40°C whereas for the dryer without the biomass heater, the product temperature inside the dryer varied from 42°C and 64°C, the product temperature outside the dryer varied from 32°C and 39°C. During the next 24 hours of the experiment (second day), the product temperature inside the dryer varied from 41°C and 69°C, the product temperature outside the dryer varied from 23°C and 41°C whereas for the dryer without the biomass heater, the product temperature inside the dryer varied from 38°C and 63°C, the product temperature outside the dryer varied from 33°C and 39°C. During the last 24 hours of the experiment (third day), the product temperature inside the dryer varied from 39°C and 64°C, the product temperature outside the dryer varied from 22°C and 34°C whereas for the dryer without the biomass heater, the product temperature inside the dryer varied from 46°C and 64°C, the product temperature outside the dryer varied from 31°C and 38°C. It is evident that the temperature of the product inside the dryer

that is coupled with the biomass heater was more than that of the dryer without the biomass heater which shows that the high temperature prevailed inside the dryer (with biomass heater) all the time even after 5PM where there would be a drop in sunshine. Thus the products obtained from the dryer that is coupled with the biomass heater will be of superior quality than the products obtained from the dryer without biomass heater and from the open sun drying method since the high temperature and low relative humidity that prevailed inside the dryer (with biomass heater) all the time irrespective of fall in sunshine, eliminated the effect of bacterial and fungal infections in the products.

H. Variation of moisture content with time

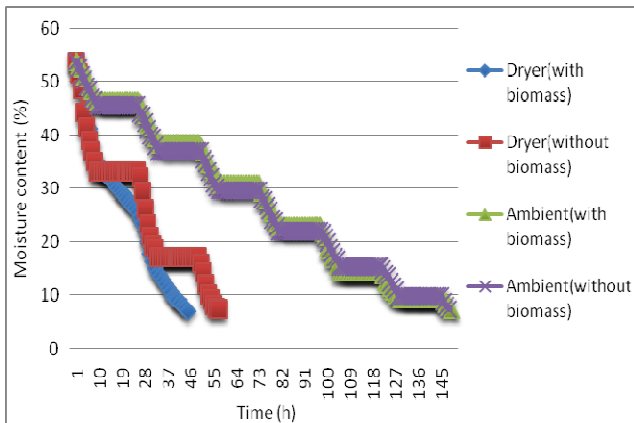

Fig. 9 Variation of moisture content with time

The fig.9 shows the variation of moisture content of the tomatoes dried under the open sun drying method and inside the dryer with biomass and without biomass heater over time during the experimental period. During the first 24 hours of the experiment (first day) in the dryer that is coupled with the biomass heater, the moisture content of the tomatoes inside the dryer reduced from 90% to 9.5% and the moisture content of the open sun dried tomatoes reduced from 90% to 55.08% whereas for the dryer without biomass heater, the moisture content of the tomatoes inside the dryer reduced from 90% to 46% and the moisture content of the open sun dried tomatoes reduced from 90% to 56%. By the end of the first day (24 hours), the moisture content of the tomatoes in the dryer that is coupled with the biomass heater, is reduced to 9.5% in just 24 hours which is the maximum rate of moisture removal from tomatoes for the process of safe storage to avoid spoilage; whereas the open sun drying method took 77 hours for the removal of moisture content from the tomatoes to the same level. During the next 24 hours of the experiment (second day) in the dryer without the biomass heater, the moisture content of the tomatoes inside the dryer reduced from 46% to 10.8% and the moisture content of the open sun dried tomatoes reduced from 55.08% to 33.18%. During the third day of the experiment, the moisture content of the tomatoes inside the dryer without the biomass heater reduced from 10.8% to 9.5% and the moisture content of the open sun dried tomatoes reduced from 33.18% to 13.5%. By the start of the third day, the moisture content of the tomatoes inside the dryer without the biomass heater, is reduced to 9.5% in 49 hours, which is the maximum rate of moisture content that can be removed from the tomatoes whereas the open sun drying method took 74 hours for the reduction of moisture content of the tomatoes to the same level. It can be seen that the dryer

coupled with the biomass heater took only 24 hours for reducing the moisture content of the tomatoes from 90% to 7.5% whereas the dryer without the biomass heater took 49 hours for reducing the moisture content to the same level. This shows that the dryer coupled with the biomass heater is more efficient in drying the products at a quicker time which is mainly due to the effect of biomass heater that steadily maintained the high temperature and low relative humidity inside the dryer even at night time. This higher rate of moisture removal from the tomatoes in the dryer (with biomass heater) is the prime reason for the reduced drying time in the dryer than that of the dryer without biomass heater and the open sun drying method.

X. CONCLUSION

Experiments were conducted in a natural convection solar tunnel greenhouse dryer coupled with biomass heater situated at Nallampalli village of Pollachi, Tamil Nadu (India) and also in a natural convection solar tunnel greenhouse dryer without biomass heater situated at Negamam village of Pollachi, Tamil Nadu (India) during the month of May, 2014 in order to experimentally study and compare the drying characteristics of tomatoes in those dryers and in the open sun drying method and also to find out optimum drying method for the drying of tomatoes. Three experimental runs with 50kgs of tomatoes were carried out in those respective dryers for drying. The mass of fuel added (after 5PM) to the biomass heater was about 7.5kg/hr. The biomass was ignited after 5PM for every one hour with fuel such as firewood, coconut shell, coconut husk and coconut fronts. It was found that the tomatoes which has the initial moisture content of 90% (w.b.) was reduced to 9.5% (w.b.) over a time period of just 24 hours in the solar tunnel greenhouse dryer coupled with biomass heater (Fig.11) whereas the dryer without the biomass heater took 49 hours for reducing the moisture content of the tomatoes to the same level. Also, the open sun drying method took 77 hours for reducing the moisture content of the tomatoes from 90% (w.b.) to 9.5% (w.b.).



Fig. 10 Comparison of tomatoes dried in solar tunnel dryer without biomass heater and with biomass heater

It was noted that in the solar tunnel greenhouse dryer that is coupled with the biomass heater, there was a steady increase in temperature all the time even when there was a drop in sunshine and also the relative humidity was low all the time inside this dryer which are all due to the effect of biomass heater coupled to the dryer. This high temperature, low relative humidity and the greenhouse effect in the dryer (with biomass heater), further accelerated the rate of moisture removal from the tomatoes which leads to the reduced drying

time than that of the dryer without biomass heater and the open sun drying method. The drying time of tomatoes in the solar tunnel greenhouse dryer coupled with the biomass heater is less than the drying time of the tomatoes in the dryer without biomass heater and the open sun drying method which is primarily due to the effect of biomass heater coupled to the dryer. Also, from the Fig. 10, it is clear that the quality of tomatoes obtained from the dryer (with biomass heater) was found to be of superior quality than that of the tomatoes obtained from the open sun drying method and the dryer without the biomass heater which is due to the high temperature and low relative humidity prevailed all day including night time that prevented the effect of fungal and bacterial infections and damage by birds and animals. Thus, in terms of drying time and product quality, the solar tunnel greenhouse dryer coupled with the biomass heater proves to be efficient in drying tomatoes than the dryer without the biomass heater and the open sun drying method.



Fig. 11 Drying of tomatoes inside the solar tunnel greenhouse dryer coupled with the biomass heater

XI. ACKNOWLEDGMENT

The financial support by Science for Equity, Empowerment & Development division of Department of Science and Technology, Govt. of India, New Delhi for this study in the framework of the project, "Popularization of solar tunnel dryers for copra production in Pollachi region (Tamil Nadu)" is gratefully acknowledged..

REFERENCES

- [1] H. A. Ensminger, E. M. Ensminger, E. J. Kolande, and K. R. Robson, (1994). Florida, USA: CRC Press. vol.2, 2nd ed. pp.2111-2114
- [2] P.N. Sarsavadia, R. L. Sawhney, D.R. Pangavhane, and S.P. Singh, "Drying behaviour of brined onion slices", *Journal of food Engineering*, 1999, vol.40, pp. 219-226.
- [3] I. Doymaz, "Air-drying characteristics of tomatoes", *Journal of Food Engineering*, 2007, vol. 78(4), pp. 1291-1297.
- [4] B. Zanoni, C. Peri, R. Nani and V. lavelli, "Oxidative damage of tomato halves as affected by drying", *Food Research International*, 1999, vol.31 (5), pp. 359-401.
- [5] A. Heredia, C. Barrera, and A. Andres, "Drying of cherry tomato by a combination of different comparison kinetics and other related properties", *Journal of Food Engineering*, 2006.
- [6] A. Midilli, and H. Kucuk., "Mathematical modeling of thin layer drying of pistachio by using solar energy", *Energy Conversion and Management*, 2003, vol. 44(7), pp. 1111-1122.
- [7] E. K. Akpınar, Y. Bicer, and C. Yildiz, "Thin layer drying of red pepper", *Journal of Food Engineering*, 2003, vol. 59(1), pp. 99-104.

- [8] E. K. Akpınar, "Drying of mint leaves in a solar dryer and under open sun: Modelling, performance analyses", *Energy Conversion and Management*, 2010, vol. 51(12), pp. 2407-2418.
- [9] M. Aghbashlo, M. H. Kianmehr, and A. Arabhosseini, "Modeling of thin-layer drying of potato slices in length of continuous band dryer", *Energy Conversion and Management*, 2009, vol. 50(5), pp.1348-1355.
- [10] T. Y. Tunde-Akintunde, "Mathematical modeling of sun and solar drying of chilli pepper", *Renewable Energy*, 2011, vol. 36(8), pp. 2139-2145.



S. Arun, Junior Research Fellow, Mechanical Engineering, Dr. Mahalingam College of Engineering & Technology, Affiliated to Anna University, Chennai, Udumalai Road, Pollachi, Publications: International Journal- 5 Nos, **Education: University/ College:** Dr. Mahalingam College of Engineering & Technology, Pollachi. **Degree:** B.E., **Year:** 2013.



N. Yashwanth, Engineer (Mechanical Engineering), **Education: University/ College:** Easwari Engineering College, Affiliated to Anna University, Chennai, **Degree:** B.E., **Year:** 2013.

R. Adharsh, Student-Mechanical Engineering, B.E., Mechanical Engineering, Dr. Mahalingam College of Engineering & Technology/Affiliated to Anna University, Chennai
Address: Udumalai Road, Pollachi, **Education: University/ College:** Dr. Mahalingam College of Engineering & Technology, Pollachi. **Degree:** Third year-B.E. Mechanical Engineering (pursuing), **Year:** 2014.