

A Survey of Active Filters

Athoub Mousa Khaled Alzuwayed

Abstract—This paper presents and reviews the response of the low pass, high pass filter, band pass filter and band stop filters. Additionally, it presents and reviews the characteristic of Chebyshev, Butterworth and Bessel and how we implement each circuit then introduce examples for Sallen-Key Low-Pass Filter, Cascaded Low-Pass Filters and Multiple-Feedback Band-Pass Filter.

Index Terms— Bessel, Butterworth, Chebyshev characteristics, Pass filters.

I. INTRODUCTION

- Filters are classified by the behavior in which the output voltage varies with the frequency of the input voltage.
- The basic active filters are classified into [1]:
 - low-pass filter
 - high-pass filter
 - band-pass filter
 - band-stop filter

Filters are networks that process signals in a frequency dependent manner. Filters have many practical applications. A simple, single-pole, low-pass filter is often used to stabilize amplifiers by rolling off the gain at higher frequencies where excessive phase shift may cause oscillations. A simple, single-pole, high-pass filter can be used to block dc offset in high gain amplifiers or single supply circuits. Filters can be used to separate signals, passing those of interest, and attenuating the unwanted frequencies. An example of this is a radio receiver, where the signal you wish to process is passed through, typically with gain, while attenuating the rest of the signals. In data conversion, filters are also used to eliminate the effects of aliases in A/D systems. They are used in reconstruction of the signal at the output of a D/A as well, eliminating the higher frequency components, such as the sampling frequency and its harmonics.

II. THE RESPONSE OF FILTERS

Now we aim to discuss the response of different types of filters

A. The Response of Low-Pass Filter

- The filter is a circuit that passes some frequencies and attenuates or rejects all the others.
- The pass-band of the filter is the range of certain frequencies that are allowed to pass inside the filter with minimum attenuation (-3dB).
- The critical frequency (the cutoff frequency) determines the end of the pass-band and is specified at the point in which the response drops -3dB of the maximum gain in the pass-band.

Manuscript Received on May 2014.

Eng. Athoub Mousa Khaled Alzuwayed, The Higher Institute of Telecommunication and Navigation, Kuwait-Elshuwaikh, Jamal Abdelnasse Street.

- The low-pass filter passes frequencies from DC to f_c and attenuates t other frequencies above f_c .
- The pass-band of the ideal low-pass filter is shown in Figure 1.
- The ideal low-pass filter bandwidth is equal to f_c (= B.W.)
- The responses of Actual filter depend on the number of poles.
- The basic low-pass filter is RC circuit consisting of resistor and capacitor. the output is shown in Figure 1-b
- The actual response is illustrated in Figure 1-a
- The gain of the low pass filter drops off slowly till the frequency reaches the critical frequency; after that the gain drops rapidly. .
- The critical frequency of the low-pass filter is :

$$F_c = 1 / 2\pi RC \quad (1)$$

- note; the output at the cut-off frequency equal to **70.7 %** of the input. This response equal to an attenuation of -3dB.
- The approximations illustrate a flat response to the critical Frequency.
- Actual low Pass Filter does not have a perfect flat response up to the critical frequency but drop to -3dB.
- to produce the filter that has a steeper transition region, it is necessary to add additional circuitry to the basic filter.
- The Filters include one or two or op-amps in the design are called active filters.

B. The Response of High-Pass Filter

- The high-pass filter attenuates or rejects all frequencies below f_c and passes all frequencies above it [2].
- The critical frequency at which the output is 70.7% of the input (-3dB), as illustrated in Figure 2.
- An RC circuit consists of one resistor and a single capacitor can be act as a high-pass filter but the output across the resistor [3].
- The cut-off frequency of the high-pass filter: $f_c = 1 / 2\pi RC$

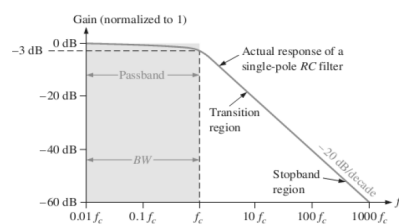

(a) Comparison of an ideal low-pass filter response (blue area) with actual response. Although not shown on log scale, response extends down to $f_c = 0$.

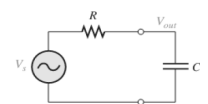

(b) Basic low-pass circuit

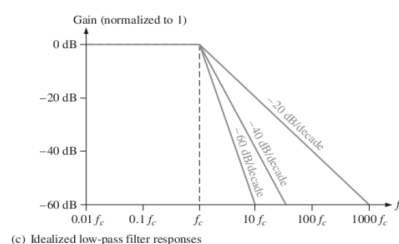

(c) Idealized low-pass filter responses

Figure 1. Low pass filter response

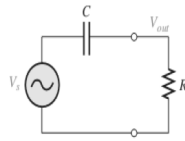
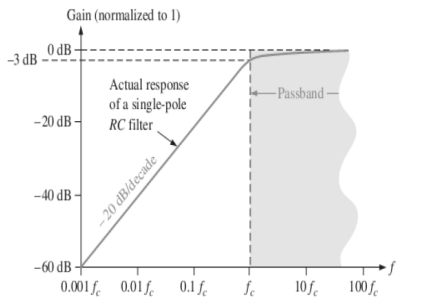

(a) Comparison of an ideal high-pass filter response (blue area) with actual response

(b) Basic high-pass circuit

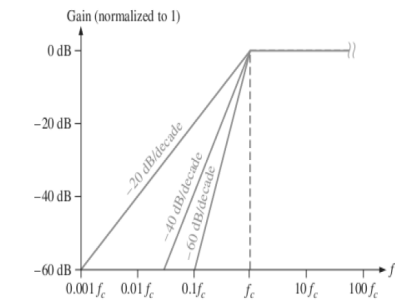

(c) Idealized high-pass filter responses

Figure 2 high pass filter response

C. The Response of Band-Pass Filter

- The band-pass filters pass all signals through lower-frequency limit and an upper-frequency limit and rejects all the others that are outside this specified band.
- The response of band-pass is illustrated in Figure 3.
- The bandwidth is the difference between the upper and lower critical frequency:

$$B.W. = F_{c2} - F_{c1} \quad (2)$$

- The points at which the response curve is 70.7% of its maximum are called The cut-off frequencies
- The **center frequency** is the frequency above which the pass-band is centered [4].

$$F_0 = \sqrt{F_{c1} * F_{c2}} \quad (3)$$

The Quality Factor: The quality factor of the band-pass filter is the ratio of center frequency to bandwidth.

$$Q = F_0 / B.W.$$

- The Q Value is an indication of the selectivity of the band-pass filter [5].
- If $Q > 10$ the band pass filter is called narrow band.
- If $Q < 10$ the band pass filter is called wide band.

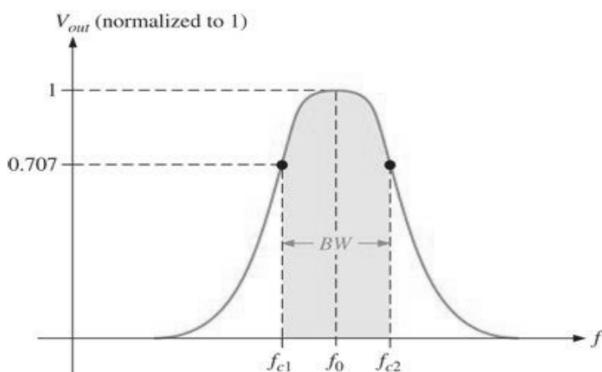

Figure 3 Band-pass filter response

D. The Response of Band-Stop Filter

- In the band pass filter the frequencies inside a certain bandwidth are rejected and frequencies outside the bandwidth are passed [6].
- The response curve for the band-stop filter is illustrated in Figure 4.

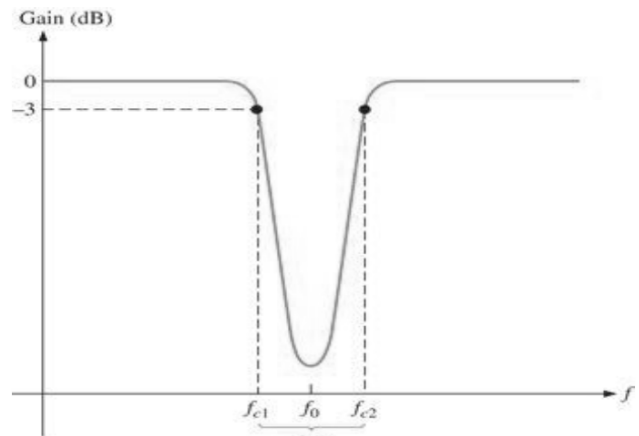

Figure 4 Band-stop filter response

III. THE CHARACTERISTICS OF FILTER RESPONSE

- We can have a Chebyshev, Bessel or Butterworth characteristics from the previous filters.
- Each of these characteristic has advantages in a some applications.
- The characteristics of Chebyshev, Butterworth, or Bessel response can be made with most active filter circuit by choosing of component values.
- The comparison among these response characteristics for a low-pass filter response curve is illustrated in Figure 5.
- Band-pass and high-pass filters can be designed to have these characteristics.

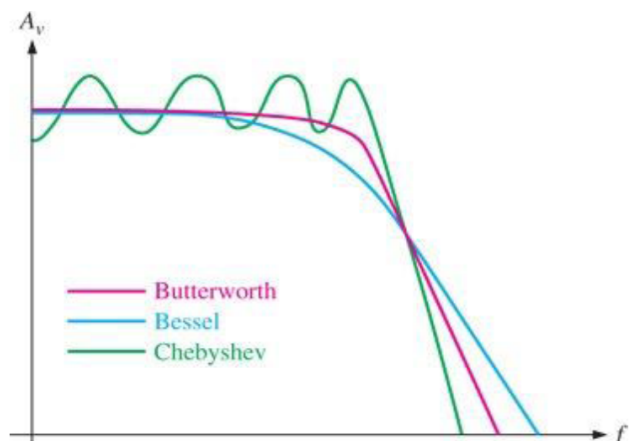

Figure 5 Comparative plots of three types of filters

A. The Characteristic OF Butterworth

- The characteristic of Butterworth gives a flat amplitude response in the pass-band.
- The phase response is not linear and the phase shift of signals passing through the filter varies nonlinearly with frequency.
- When all frequencies in the pass-band have the same gain we can use filters with the Butterworth response.

B. The Characteristic Of Chebyshev

- Filters with the characteristic of Chebyshev response are used when a rapid roll-off is required.
- Filters can be designed by the Chebyshev response with less poles and less complex circuit for a required roll-off rate.

C. The Characteristic Of Bessel

- In The Characteristic of Bessel the phase shift increases linearly with frequency.
- Hence, no overshoot on the output by a pulse input. Hence, filters with the response of Bessel are used to filter the pulse waveforms without waveform Distortion.

The Damping Factor

- The active filter can be Implemented to have Chebyshev Butterworth, or Bessel response characteristic.
- Figure 6 includes a negative feedback circuit, an amplifier, and a filter. The amplifier and feedback are connected in a non-inverting way [7].
- The negative feedback circuit determines the damping factor by the following Equation:

$$D.F.=2-R_1/R_2 \quad (4)$$

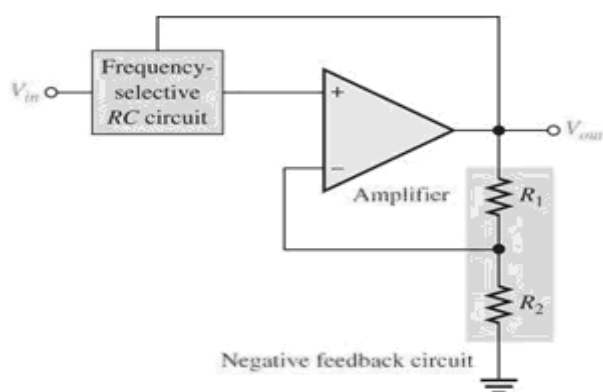

Figure 6 Negative feedback circuit

IV. CRITICAL FREQUENCY

- The capacitors and resistors values can determine the Cut-off frequency in the RC circuit as in Figure 7.
- The cut-off frequency of a single pole (i.e. 1st order) filter is:

$$F_c = 1/2\pi RC \quad (5)$$

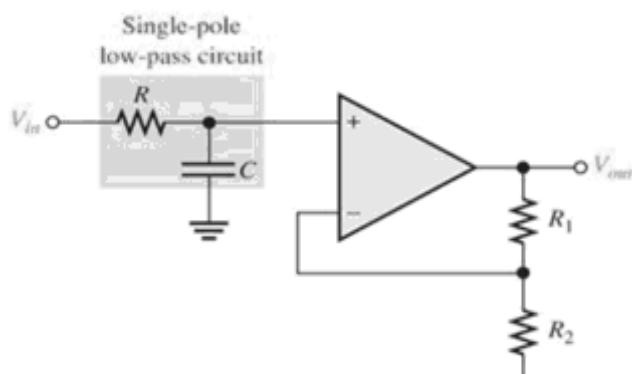

Figure 7 Single-pole low-pass circuit

-In order to get a filter with three poles or more [9], we have to implement a cascades filters with single pole or two poles as shown in Figure 8.

- In order to get a third-order filter, we have to cascade a second-order and a first-order filter.
- In order to get fourth-order filter, we have to cascade two second-order filters and so on.
- Butterworth characteristic is the most widely used Because of its flat response.

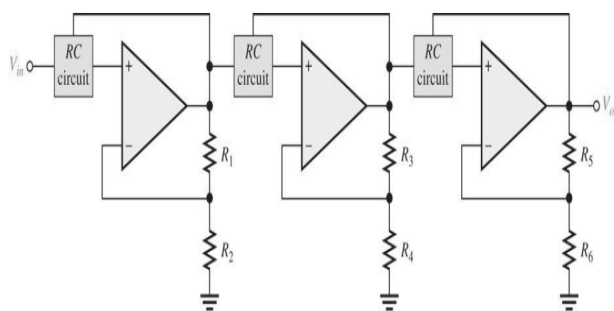

Figure 8 The number of filter poles can be increased by cascading

A. Active Low Pass Filters

- Advantages of filters that use op-amps as the active element over passive filters (RLC) are [8]:

- low output impedance
- high input impedance
- The op-amp provides gain

Single Pole Filter

-In Figure 9, the op-amp is connected as a non-inverting amplifier with a closed-loop voltage gain in the pass-band and determined by the R1 and R2 values [10].

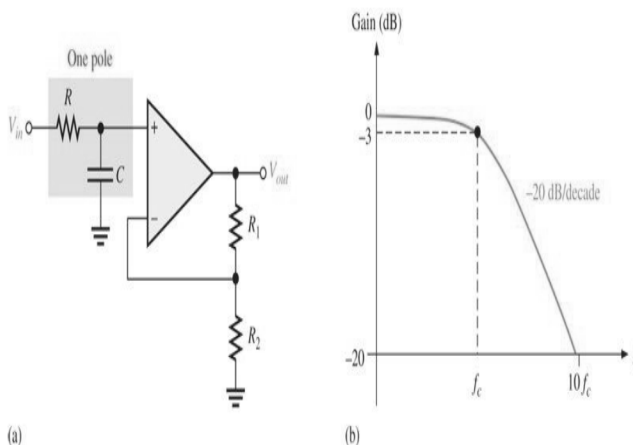

Figure 9 Single-pole active low-pass filter and response curve.

B. The Sallen-Key Low-Pass Filter

- One of the most common Circuits is The Sallen-Key as a second-order filter.
- The Sallen-Key circuit is shown in Figure 10.
- The circuit contains two low-pass RC (in case of a Butterworth characteristic).

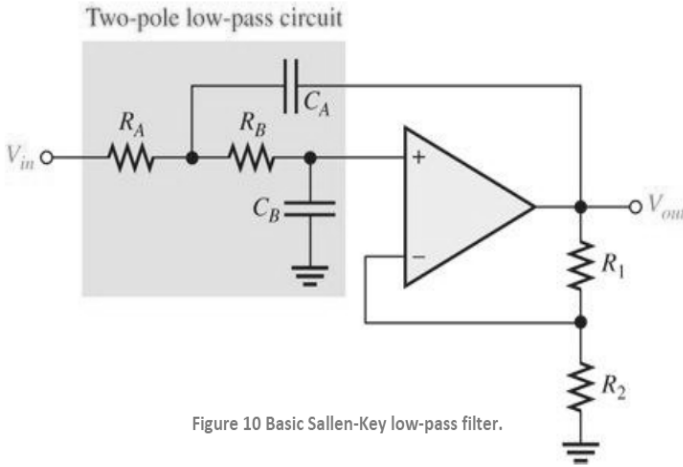
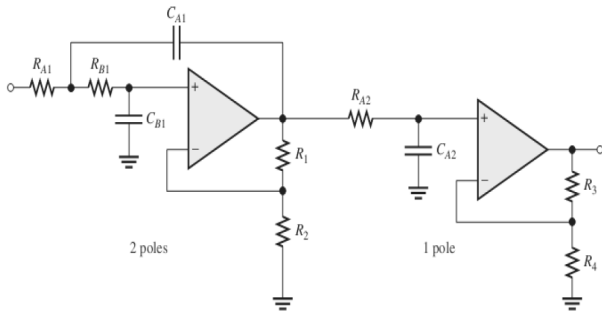

Figure 10 Basic Sallen-Key low-pass filter.

C. Cascaded Low-Pass Filters

-In order to get a third order low pass response, a three-pole filter is required
 - in order to get this, we have to cascade two-pole Sallen-Key with a single-pole low pass filter as in Figure 11.



(a) Third-order configuration

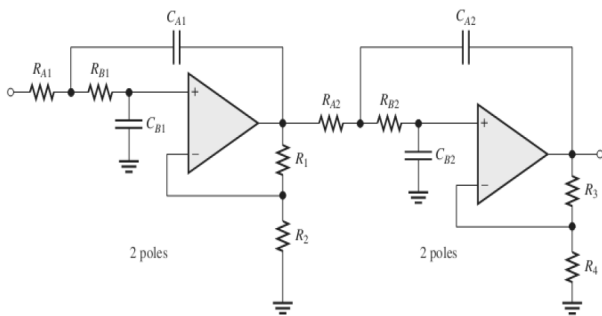

(b) Fourth-order configuration

Figure 11 Cascaded low-pass filters.

D. Active High Pass Filters

- In high-pass filters, the roles of the capacitor and resistor are reversed in the RC circuits [11].
 - Otherwise, the basic parameters are the same as for the low-pass filters.

Single Pole Filter

- A high-pass active filter with a -20dB/decade roll-off is shown in Figure 12(a).
 - Notice that the input circuit is a single high-pass RC circuit.
 - The negative feedback circuit is the same as for the low-pass filters previously discussed. The high-pass response curve is shown in Figure 12(b).

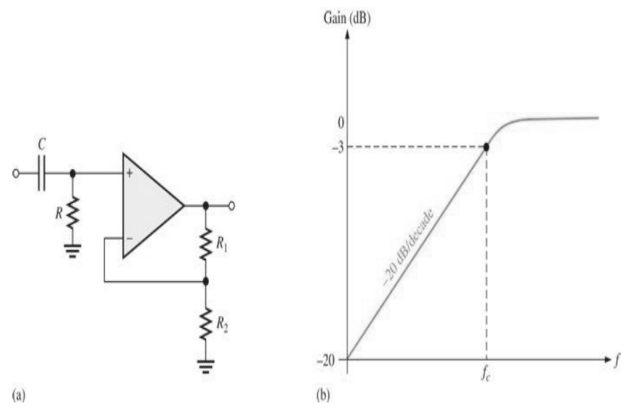

Figure 12 Single-pole active high-pass filter and response curve.

E. Example for The Sallen Key High Pass Filter

We can implement the Sallen Key Filters as Figure 13.

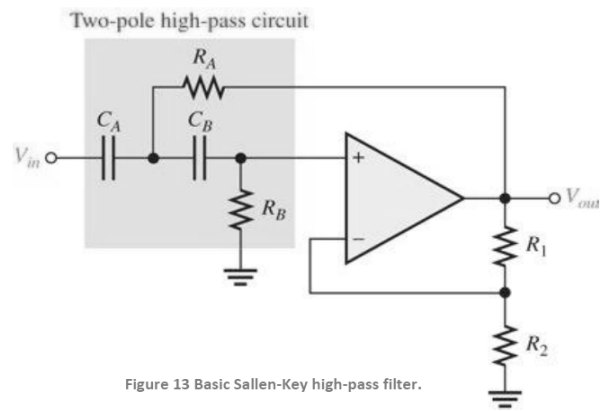

Figure 13 Basic Sallen-Key high-pass filter.

F. Example for Cascading High-Pass Filters

Cascading High-Pass Filters can be implemented as in Figure 14.

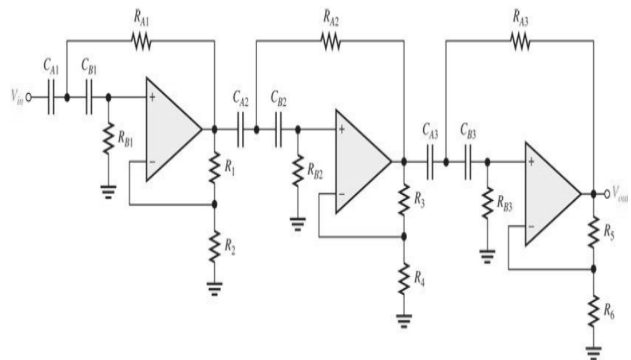

Figure 14 Sixth-order high-pass filter.

G. Example for Multiple-Feedback Band-Pass Filter

Multiple-Feedback Band-Pass filters can be implemented as in Figure 15.

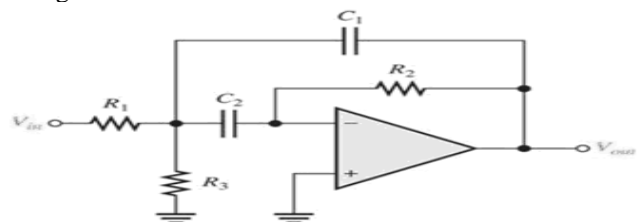

Figure 15 Multiple-feedback band-pass filter

V. CONCLUSION

The paper has presented the response of the low pass, high pass filter, band pass filter and band stop filters. Additionally, we can have a Chebyshev, Bessel or Butterworth characteristics from the previous filters. Each of these characteristics has advantages in a some applications. By choosing of component values, the characteristics of Chebyshev, Butterworth, or Bessel response can be made with most active filter circuit.

REFERENCES

- [1] L. P. Huelsman and P. E. Allen, *Introduction to the Theory and Design of Active Filters*, McGraw Hill, 1980, ISBN: 0-07-030854-3.
- [2] H. Zumbahlen, *Passive and Active Filtering*, Analog Devices AN281.
- [3] A. I. Zverev, *Handbook of Filter Synthesis*, John Wiley, 1967.
- [4] A. B. Williams, *Electronic Filter Design Handbook*, McGraw-Hill, 1981, ISBN: 0-07-070430-9.
- [5] M. E. Van Valkenburg, *Analog Filter Design*, Holt, Rinehart & Winston, 1982.
- [6] A. I. Zverev and H. J. Blinichkoff, *Filtering in the Time and Frequency Domain*, John Wiley and Sons, 1976.
- [7] S. Franco, *Design with Operational Amplifiers and Analog Integrated Circuits*, McGraw-Hill 1988, ISBN: 0-07-021799-8.
- [8] Aram Budak, *Passive and Active Network Analysis and Synthesis*, Houghton Mifflin Company, Boston, 1974.
- [9] R. W. Daniels, *Approximation Methods for Electronic Filter Design*, McGraw-Hill, New York.
- [10] E. H. Watanabe, H. Akagi, M. Aredes, "The p-q Theory for Active Filter Control: Some Problems and Solutions", *Trans. on Revista Control and Automation*, Vol. 15 no. 1/Jan., Fev. e Maro 2004
- [11] J. R. Bainter, *Active Filter Has Stable Notch and Response Can be Regulated*, Electronics, Oct. 2 1975, pp.115-11