

# Design & Implementation of Smart House Control Using LabVIEW

Basil Hamed

**Abstract**— Smart home is a house that uses information technology to monitor the environment, control the electric appliance and communicates with the outer world. Smart home is a complex technology, at the same time it is developing. A smart home automation system has been developed to automatically achieve some activities performed frequently in daily life to obtain more comfortable and easier life environment. A sample house environment monitor and control system that is one branch of the Smart home is addressed in this paper. The system is based on the LabVIEW software and can act as a security guard of the home. The system can monitor the temperature, humidity, lighting, fire & burglar alarm, gas density of the house and have infrared sensor to guarantees the family security. The system also has internet connection to monitor and control the house equipment's from anywhere in the world. This paper presents the hardware implementation of a multiplatform control system for house automation using LabVIEW. Such a system belongs to a domain usually named smart house systems. The approach combines hardware and software technologies. Test results of the system have shown that it can be easily used for the smart home automation applications.

**Index Terms**— Smart House, LabVIEW, PIC16F877A, Data Acquisition Card, Remote Control.

## I. INTRODUCTION

With the development of new electronic technologies and their integration with older, traditional building technologies, smart house is at last becoming a real possibility. Possibly the first "home computer" was an experimental system in 1966. The Smart House Project was initiated in the early 1980's as a project of the National Research Center of the National Association of Home Builders (NAHB) with the cooperation of a collection of major industrial partners [1]. Smart House is not a new term for science society but is still far more away from people's vision and audition. This is because although recent various works has been done in designing the general overview of the possible remote access approaches for controlling devices [2], or in cases simulating the Smart House itself [3], and designing the main server [4], the design and implementation of an off-the-shelf Smart House remote control application has been limited to simply the computer

applications and just in cases mobile [5] and web applications development [6]. The "smart house" technology is one realization of home automation ideals using a specific set of technologies. It's a house that has highly advanced automatic systems for lighting, temperature control, security, appliances, and many other functions. Coded signals are sent through the home's wiring to switches and outlets that are programmed to operate appliances and electronic devices in every part of the house. A smart home appears "intelligent" because its computer systems can monitor many aspects of daily living. As the number of controllable appliances in the home rises, the ability of these devices to interconnect and communicate with each other digitally becomes a useful and desirable feature. The consolidation of control or monitoring signals from appliances, fittings or basic services is an aim of home automation. Smart house technology can interface basically using computer interface. Smart house can also provide a remote interface to home appliances or the automation system itself, via telephone line, wireless transmission or the internet, to provide control and monitoring via a smart phone or web browser [7].

This paper presents smart house controlled by LabVIEW that controls main system. The main system consists of five parts; these five parts are connected to LabVIEW software as the main controller for these systems. The first subsystem in smart house project is security systems that include fire alarm system used in announcing the outbreak of a fire and work to extinguish the fire, and burglar alarm system that signals the occurrence of a burglary. The second subsystem is lighting system that include the internal lighting of the house, and the ceil lighting outside the house. The third subsystem is remote control system for house controlling. The fourth subsystem is temperature system for air conditioner controlling. The fifth subsystem is Main house power switching system to switch the power supply for all rooms in the house.

The smart house has two interfaces, computer interfacing, and remote control unit interfacing. Computer device that provided with LabVIEW software is the main controller unit for all systems in the house. It receives data from house sensors, process information and updates data for the difference systems, and transmit controlling signal to house systems and switching output devices. In addition, LabVIEW make the ability to monitor the important operations in the system to the users in order to be informed of the changes in the system. Users can also control the difference systems abilities, and chose the best system that required. In addition to LabVIEW interface for the smart house, remote control interfacing is available to control some applications in the house, and it is connected to LabVIEW software for other

**Manuscript received November 09, 2011.**

**Basil Hamed**, Electrical Engineering Department, Islamic University of Gaza, Gaza. Palestine, Phone/ Mobile No0+970 (59)9346997 (e-mail: bhamed@iugaza.edu).

applications. Figure 1 shows the block diagram of the smart house designed in this paper.

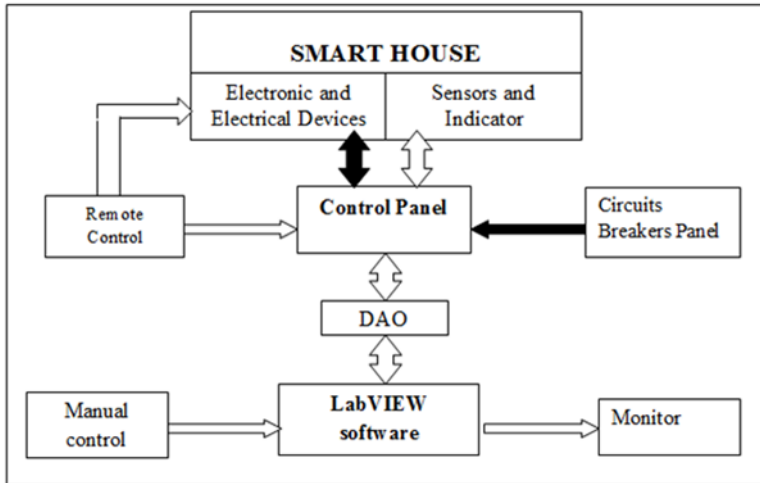

Figure 1 Smart House Block Diagram

## II. LABVIEW

NI LabVIEW software is used for a wide variety of applications and industries. LabVIEW is a highly productive development environment for creating custom applications that interact with real-world data or signals in fields such as science and engineering. The net result of using a tool such as LabVIEW is that higher quality projects can be completed in less time with fewer people involved. So productivity is the key benefit, but that is a broad and general statement. LabVIEW is unique because it makes this wide variety of tools available in a single environment, ensuring that compatibility is as simple as drawing wires between functions. LabVIEW itself is a software development environment that contains numerous components, as shown in Figure 2 [8].

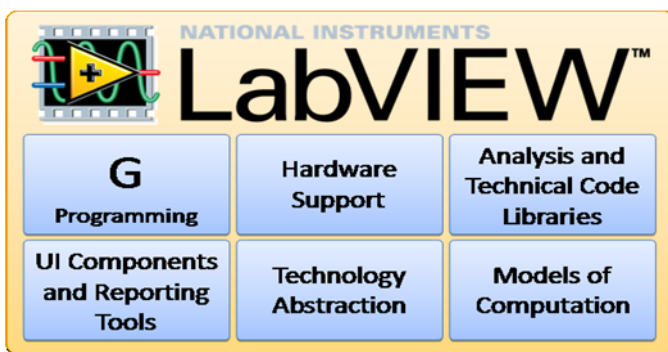

Figure 2 LabVIEW Valuable Components

### A. G Programming Language

The G programming language is central to LabVIEW; so much so that it is often called “LabVIEW programming.” Using it, you can quickly tie together data acquisition, analysis, and logical operations and understand how data is being modified. From a technical standpoint, G is a graphical dataflow language in which nodes (operations or functions) operates on data as soon as it becomes available, rather than in the sequential line-by-line manner that most programming languages employ [9]. You lay out the “flow” of data through

the application graphically with wires connecting the output of one node to the input of another. LabVIEW contains a powerful optimizing compiler that examines your block diagram and directly generates efficient machine code, avoiding the performance penalty associated with interpreted or cross-compiled languages. The compiler can also identify segments of code with no data dependencies (that is, no wires connecting them) and automatically split your application into multiple threads that can run in parallel on multicore processors, yielding significantly faster analysis and more responsive control compared to a single-threaded, sequential application. [10]

### B. Hardware Support

LabVIEW Support for thousands of hardware devices, including:

Scientific instruments, Data acquisition devices, Sensors, Cameras, Motors and actuators, Familiar programming model for all hardware devices, Portable code that supports several deployment targets

LabVIEW makes the process of integrating hardware much easier by using a consistent programming approach no matter what hardware you are using. The same initialize-configure-read/write-close pattern is repeated for a wide variety of hardware devices, data is always returned in a format compatible with the analysis and reporting functions, and you are not forced to dig into instrument programming manuals to find low-level message and register-based communication protocols unless you specifically need to. LabVIEW has freely available drivers for thousands of NI and third-party hardware [11]. In the rare case that a LabVIEW driver does not already exist, you have tools to create your own, reuse a DLL or other driver not related to LabVIEW, or use low-level communication mechanisms to operate hardware without a driver.

### C. UI Components and Reporting Tools

Interactive controls such as graphs, gauges, and tables to view your acquired data. Tools to save data to file or databases, or automatically generate reports. Every LabVIEW block diagram also has an associated front panel, which is the user interface of your application. On the front panel you can place generic controls and indicators such as strings, numbers, and buttons or technical controls and indicators such as graphs, charts, tables, thermometers, dials, and scales. All LabVIEW controls and indicators are designed for engineering use, meaning you can enter SI units such as 4M instead of 4,000,000, change the scale of a graph by clicking on it and typing a new end point, export data to tools such as NI DIAdem and Microsoft Excel by right-clicking on it, and so on [12]. Controls and indicators are customizable. You can add them either from a palette of controls on the front panel or by right-clicking on a data wire on the block diagram and selecting “Create Control” or “Create Indicator.”

### D. Models of Computation

Simulation syntax, textual math, state charts, component-level IP (CLIP) nodes, DLL calls, and other models are available for whenever G is not the most natural representation of the solution. Incorporate and reuse existing code and IP to minimize development effort [12]. When LabVIEW was first released, G was the only way to define the functionality

needed. Much has changed since then. With LabVIEW, you can now pick the most efficient approach to solve the problem at hand.

**E. Technology Abstraction**

- Harness emerging technologies such as FPGAs, multicore CPUs, and virtualization without painful relearning and additional development effort.
- Use common protocols and platforms without getting bogged down by details [12].

Technology advances at a rapid pace and the pressure to keep current and take advantage of state-of-the-art performance is rarely matched with enough time and training to learn and implement emerging technologies. LabVIEW addresses this problem by quickly adopting advances in personal and embedded computing in such a way; that you get the new capabilities without having to learn significant new paradigms. Examples of this approach include how LabVIEW is able to automatically generate multithreaded code for execution on multicore processors or program FPGAs to gain the speed and reliability of custom hardware chips without the LabVIEW user needing to learn the underlying details of multithreading or the hardware description languages typically required to use FPGAs. The same applies to new OSs, networking protocols, and more.

**F. Models of Computation**

- Simulation syntax, textual math, state charts, component-level IP (CLIP) nodes, DLL calls, and other models are available for whenever G is not the most natural representation of the solution.
- Incorporate and reuse existing code and IP to minimize development effort.

When LabVIEW was first released, G was the only way to define the functionality you needed. Much has changed since then. With LabVIEW, you can now pick the most efficient approach to solve the problem at hand. Examine the following considerations [12]:

- Graphical data flow is the default model of computation for LabVIEW.
- State charts provide a higher level of abstraction for state-based
- Simulation diagrams are a familiar way of modeling and analyzing dynamic systems.
- Formula Node puts simple mathematical formulas in line with your G code.
- LabVIEW MathScript is math-oriented, textual programming for LabVIEW that you can use to call .m files without the need for extra software.
- CLIP and IP integration nodes import FPGA intellectual property so you can use VHDL.

These flexible models of computation allow picking the right tool for the particular problem you are trying to solve. In any given application you will likely want to use more than one approach, and LabVIEW is the perfect tool to quickly tie everything together.

**III. DESIGN**

With technological advances, the control in smart house systems evolve and include new and sophisticated methods based on different control programs and systems. In this paper we use LabVIEW program, and remote control to control the

different systems in the smart house model. The control of the smart house is divided into two different types of control as shown in Figure 3.

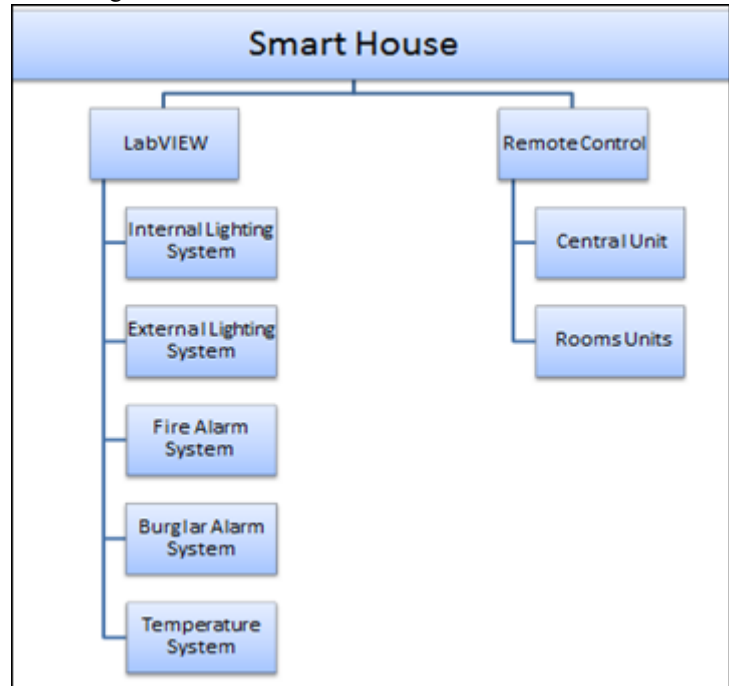

Figure 3 Smart House Control

**A. LabVIEW Control**

The LabVIEW software will control the internal lighting, external lighting, fire alarm, burglar alarm, and temperature Systems in the house.

**1. Internal lighting System:** The internal lighting system consists of a PIR motion sensor, dimmer and lamps which there are in contact with LabVIEW software program. This system will make an automatically lighting in the house when there is any movement inside it. Dimmer can use to make a small lamp lighting percentage, and LabVIEW will make 100% lighting for the lamp when it receives a movement signal from PIR motion sensor and the user can scheduler the time of running the system. When the PIR motion sensor detects a moving object, it will send a signal but it will be for a specific little time. For this reason, 555 timer circuit is used to generate accurate time delays that will be more suitable for lamp lighting inside the house. The LabVIEW software program user can monitor the system by the LabVIEW front panel monitor screen as shown in Figure 4. The LabVIEW block diagram of internal lighting system is shown in Figure 5.



Figure 4 Internal Lighting System LabVIEW Front Panels, Monitor Screen

**2. External lighting System:** External lighting system depends on the reading of sun cell. The DAQ will transform the analog signal got from the sun cell to digital

signal and send it to LabVIEW to analysts it. The LabVIEW software program can select the time of morning and night time to control the status of external light lamps. The LabVIEW software program will read and process the sun cell value and indicate to status of day \_ morning or night \_ in LabVIEW front panel monitor screen , and block diagram as shown in Figure 6

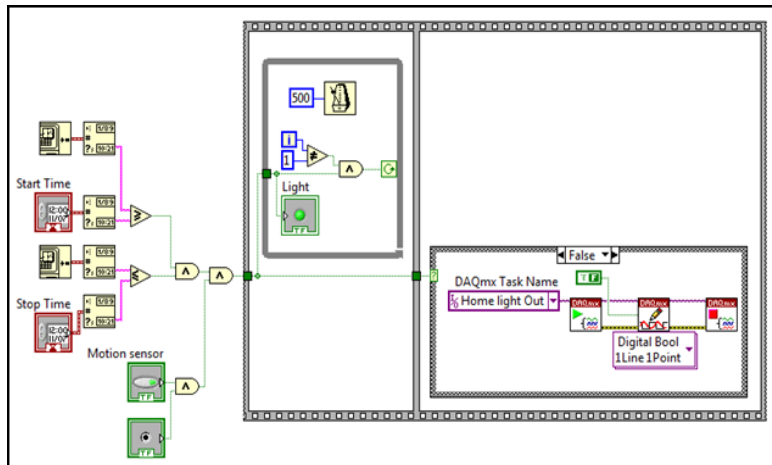
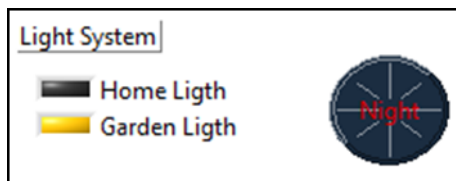
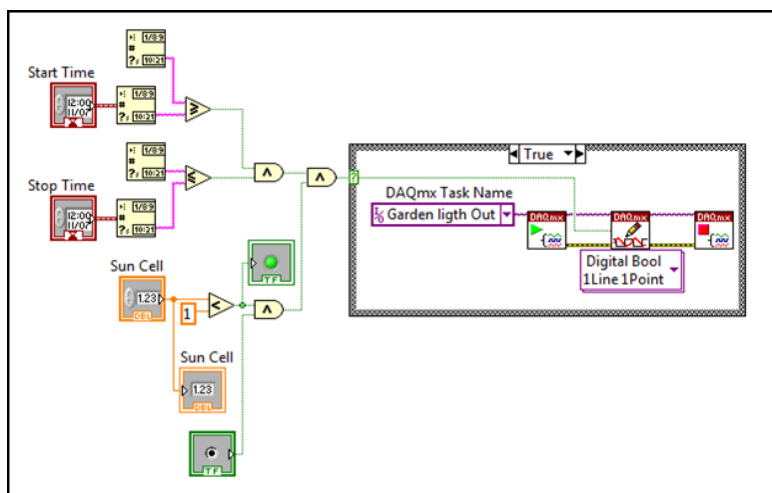

Figure 5 Internal Lighting System LabVIEW Block Diagram



(a)



(b)

Figure 6 LabVIEW External lighting Systems (a) Front Panels, Monitor Screen (b) LabVIEW Block Diagram

**3. Fire Alarm System:** is divided into three parts, the first part is the signal that reach from fire alarm system sensors as an indicator for announcing the outbreak of a fire in the house, the second part is the output signal that send after the processing of input signal, and finally the controlling system and data processing by LabVIEW. There are many types of sensors which used in fire alarm system. Smoke detector and heat detector are used in the smart house. For fire alarm warning and for control the spread of fire and

smoke, three applications are used to achieve the goal. We started with using alarm siren to generate a load wailing sound to express the presence of risk; moreover, we use gas solenoid valve to cut off the flow of gas to the house. In addition, the system will send a short message service (SMS) to house owner and to the firefighter's office to inform them of the existence of fire. LabVIEW will receive the signal from fire alarm sensor. After processing the input data, LabVIEW will send a set signal to alarm siren to make a load sound; also, this signal will set the gas solenoid valve to cut off the flow of gas to the house. Next to the implementation of those orders, LabVIEW will send a mobile message to inform the owner of the house about the risk of fire. After a specific time which can be adjusted as required, LabVIEW will send another SMS to the firefighting office to inform them for the need of help to fire suppression.

To control the alarm siren set and gas solenoid valve reset by LabVIEW software program we ought to use driver between the DAQ and alarm siren and gas solenoid. So, two 5v relay are used to run the two devices (Figure 7). The first relay is N.O. relay and their contacts connect to 24 DC voltages to run the alarm siren. The second relay is N.C. relay and its contacts connected to 220 AC voltages to run the gas solenoid valve

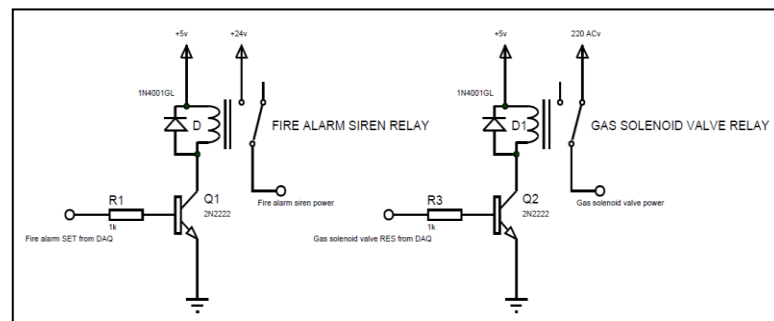

Figure 7 Fire Alarm Siren and Gas Solenoid Relay Implementation

The LabVIEW software program gives a flexibility to select the steps that the program should do. When a fire or Burglar exist, select if the system should run the alarm siren or not, and if it should send SMS or not. LabVIEW front panel monitor screen shown in Figure 8 and LabVIEW block diagram is shown in Figure 9.

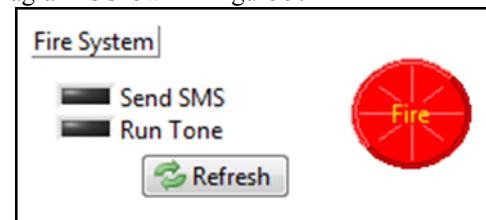

Figure 8 Fire Alarm System LabVIEW Front Panel Monitor Screen

**4. Burglar Alarm System:** The design of Burglar alarm system used in smart house system is similar to the design used for fire alarm system. It is divided into three parts; the first part is the signal that reaches from burglar alarm sensors when its trigger threshold has been reached after any a specific danger in the house. The second part is the output signal that send after the processing of input signal,

and final part is the controlling system and data processing by LabVIEW

the time of running the system , as shown in Figure 12.

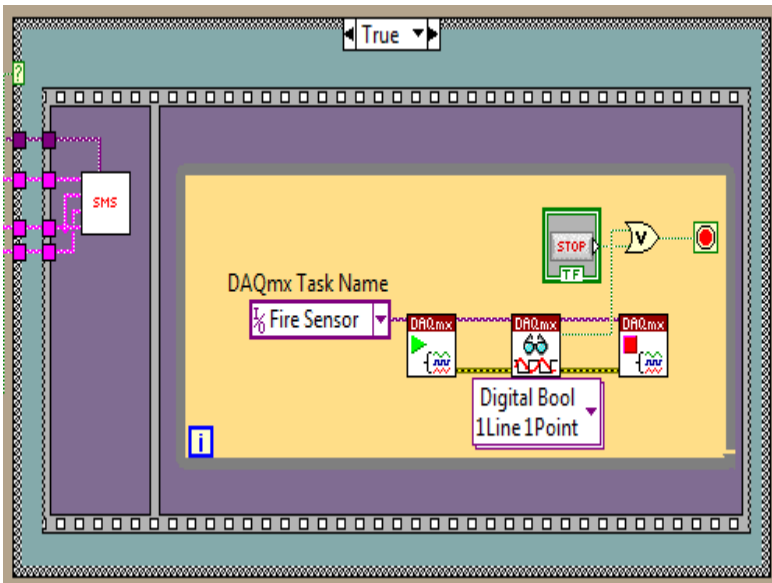

Figure 9 LabVIEW Fire Alarm System Block Diagram

**5. Temperature System:** The basic element in temperature system is the reading of temperature value from temperature sensor. For that, LM35 temperature sensor is used. This sensor is connected directly with DAQ. LabVIEW reads the signal from LM35 sensor as variable analog value. After processing the structure in the program, LabVIEW will send a cooling or heating signal to the system, depending on the value of the sensor and the critical value of temperature that required. In the mechanism of temperature system programming, PWM system is used to control the heating and cooling devices. 5V DC power supply is used to operate LM35 sensor. We used TIP41 transistor because it has the ability to switch on/off for several pulse in its base in a little period of time as shown in Figure 10.

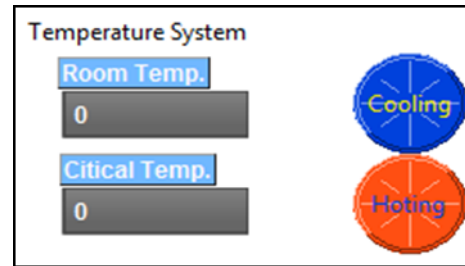

Figure 11 Temperature System LabVIEW Front Panel Monitor

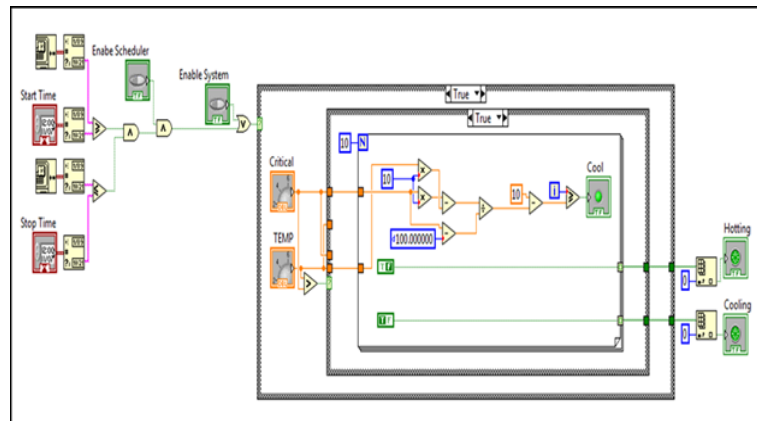

Figure 12, Temperature System LabVIEW Front Panel, Setting Screen

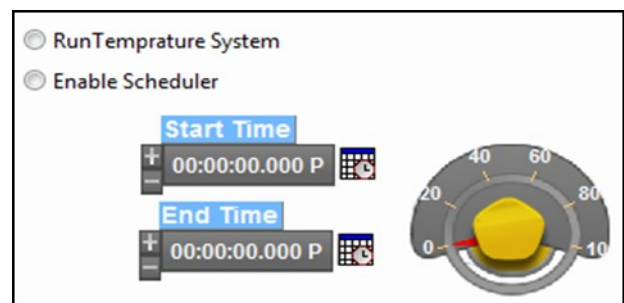

Figure 13 Temperature System Programming Circuit

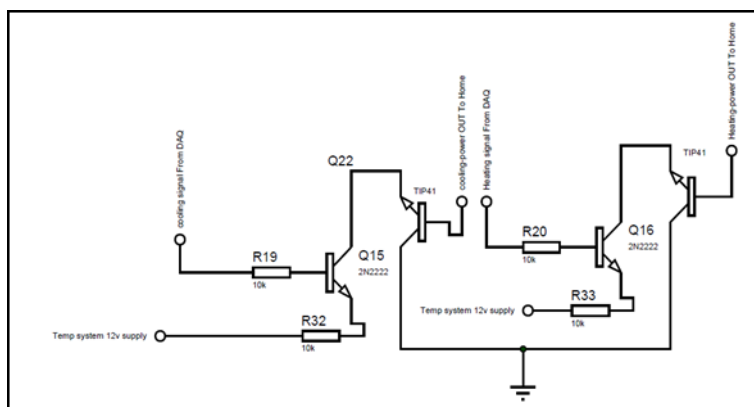

Figure 10, Cooling and Heating Signal in Temperature System

By the LabVIEW software program user can be monitor the system by the LabVIEW front panel monitor screen (Figure 11) , as well as can be set the configuration of the Temperature system as Run or Stop the system and scheduler

**B. Central Unit and Rooms Units Remote Control**  
 Remote control is one of two interfacing device used in smart house application. It's a device used to remote operation of a specific system. In many smart house applications, remote control used to send control signal to the central control unit in the system to make some operation. The remote control is used to make some operation in the system by connection with LabVIEW software. In addition, it is used to control and to switches the load in every room in the house using the room unit receiver in every room.

Interfacing smart house with remote control is an important application in this system. The remote control system is divided into three part, transmitter unit, central receiver unit, and rooms' receiver units. Transmitter unit is the remote control unit that enables the user to control the two difference receiver units. Central receiver unit is the receiver from the remote control which connected with LabVIEW to make some central operation in the house. Room receiver unit is to

control a room load via remote control. In smart house system both RF module and IR systems are used to make connection between remote control unit and receiver unit. RF module can transmit to about 200 ft. in building and 700 ft. in open ground. IR system needs line of side directing between transmitter and receiver, so it can be used inside the house rooms not in the entire house. Remote control unit has 11 control switches divided into two parts. The first part is related to central receiver unit which connected to LabVIEW. The second part of remote switches is related to room receiver unit that enable the user to switch on/off for four loads in every room in the house.

**1. Transmitter remote control implementation**

Both RF Module and IR systems are used to implement the remote control system. PIC16F877A is used as a controller and a processing unit in remote control unit as shown in Figure 14.

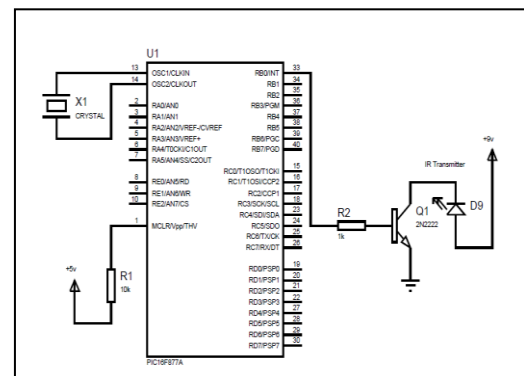

Figure 14 Remote Control Unit

PIC16F877A is programmed to have eleven input port and six output port to implement the remote control. All of the inputs are connected with button switch to send a signal to PIC16F877A for the difference operation in the system. For output port, four are used to send a parallel code to the RF Module encoder. Then transfer it to serial code and send it to RF module transmitter unit. Also one port is used to send data to IR transmitter, and finally another port is used to connect it with led to make indicator for sending data from PIC16F877A.

Mechanism for using input and output ports in the remote control (Figure 15), every port is related to a specific operation in the system. For the button switch and input port, the eleven button switch divided into two parts in programming system, four of these switches are related to room's receiver units, and the other seven switches related to central receiver unit. In four output port that used to send parallel data to RF Module, we send a difference code for every operation in the remote via four ports. This means that when any of the button switch is SET, PIC16F877A will send a code to RF Module encoder. In IR output port, PIC16F877A (Figure 16) will send a data to IR transmitter related to switch the four button switch that made for rooms receiver units. Finally, the port that connected to led is made to make an indicator for user that the output signal is send from remote control unit or not . Toggle system used in all four switch to enable the user to switch on/off the different loads using the same switch. When one of the four switches that related to room receiver unit is switch, PIC16F877A will send three outputs in the same time. The first output is send to IR transmitter as a pulse which has 38 KHz frequency. We make these pulses by making 1 logic level and another 0 logic, and both of them is divided into sub pulses to make the wanted frequency. PIC16F877A is used to generate this frequency. IR output signal enter a base of transistor that enable us to reduce the applied voltage in the IR transmitter.

The second output is send to RF module encoder it's consist of four bits that send parallel to the encoder. For every switch of the four buttons, have a special code that differs from the other codes, by this; we can control four loads in the room. The third output is send to a led output device to make an indicator for sending the data from remote control. For any



switching, PIC16F877A will send a pulse to the led.

Figure 16, IR transmitter connection with PIC16F877A

Connection between remote control unit and central receiver unit in the house is made using only RF Module to enable the user to control the system in any place inside the house.

**2. Central receiver unit implementation:** This unit of remote control is central installed unit in the house because of its connection with LabVIEW via DAQ. These units enable the user to make two different models in the house using three switches in the remote control unit. Besides that, there is also two output signal to central house's control panel, the first one is to make RES for fire alarm system in

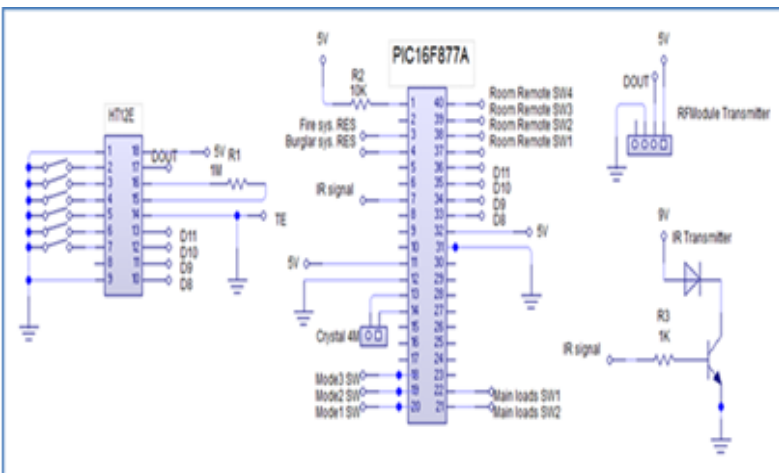
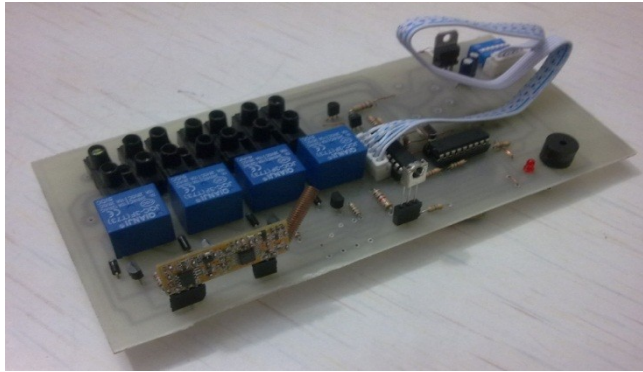

Figure 15 Circuit Diagram For Remote Control Unit

the house, and the second one is to make RES for burglar



alarm system (Figures 17, 18).  
Figure 17 Central Receiver Unit

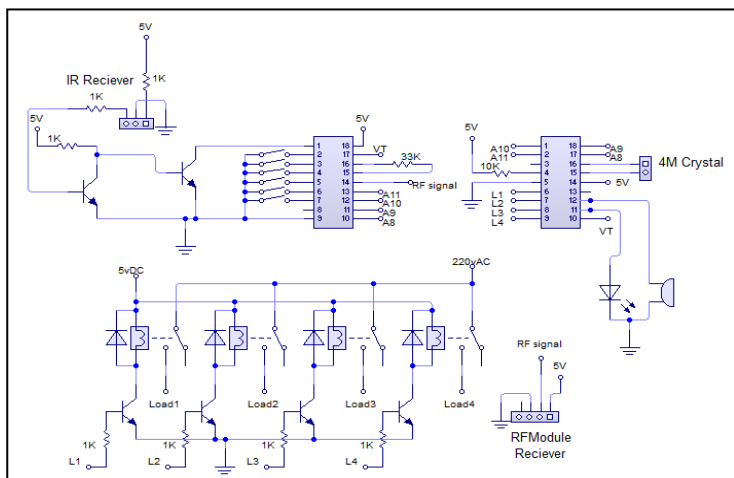

Figure 18 Circuit Diagram for Central Receiver Unit

**3. Room receiver unit implementation:** The central idea of room's loads control is to install a room receiver unit in every room that wants to control its load. Every unit can control four loads in the room installed in it. Using both IR system and RF Module make the control of the room load confined within the room only because of using IR system that need line of site transmission inside the room. In the rooms receiver units we used PIC16F84A to receive four parallel bits from RF module decoder after transfer the serial data from RF module receiver. The different codes that received from RF module change inside PIC16F84A to four output line with connected to transistor and 5v relay for every load where the contact of the relay can connect with the load lines to switch the power that entered to it (Figures 19, 20).



Figure 19, Room Receiver Unit

In the same time of switching the different load, PIC16F84A will send output signal to buzzer to make a sound as indicator about the change in the loads condition; that means that every buzzer sound give us a sense that the load is on or off. IR receiver output signal is connected with one pin of coding pins of RF module decoder. This pin will be activated when the IR signal reach the room receiver unit, and in the same time the same pin in RF module encoder in remote control unit is originally connected as same way in the decoder IC. Using this way enables us to connect the two side of RF module only when the remote control unit is guided to room receiver unit, and this system give us the ability to install room receiver unit in any room inside the house.

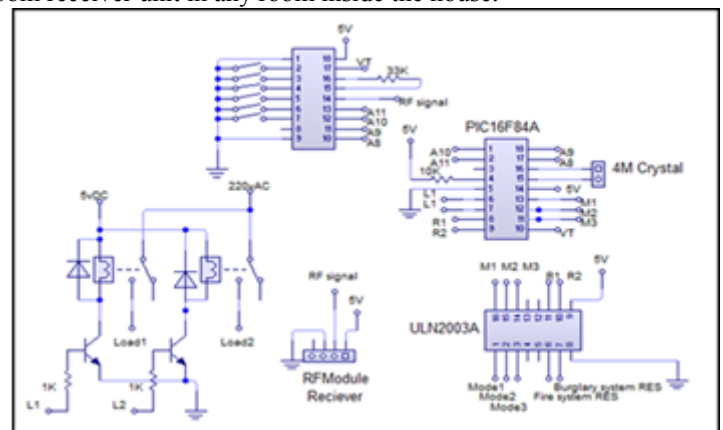

Figure 20, Circuit diagram for Room Receiver Unit

#### IV. LABVIEW SOFTWARE INTERFACE

The main controller of smart house is the LabVIEW as shown in Figure 21.

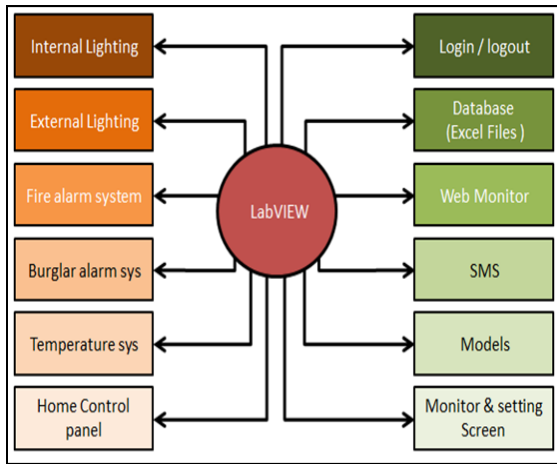

Figure 21 LabVIEW Control of Smart House

The LabVIEW interfacing with smart house system consists of two main parts:

**A. Monitor Screen**

Monitor screen is designed using LabVIEW allows monitoring to all parts of smart house system that connected with LabVIEW via Data Acquisition Card is shown in Figure 22.



Figure 24 LabVIEW Program, Login Monitor Screen

**1. Data storage**

In this software system all process will be stored in Excel file as shown in Figure 25

H	G	F	E	D	C	B	A	
Garden Ligh	Cell value	Home Ligh	Motion sensor	Module	Time	Data	Index	1
TRUE	0.716699	FALSE	FALSE	Module No. 1	1:30:45 AM	4/28/2011	1	2
TRUE	0.67596	FALSE	FALSE	Module No. 1	1:30:45 AM	4/28/2011	2	3
TRUE	0.739614	FALSE	FALSE	Module No. 1	1:30:46 AM	4/28/2011	3	4
TRUE	0.752345	FALSE	FALSE	Module No. 1	1:30:46 AM	4/28/2011	4	5
TRUE	0.739614	FALSE	FALSE	Module No. 1	1:30:47 AM	4/28/2011	5	6
TRUE	0.74216	FALSE	FALSE	Module No. 1	1:30:47 AM	4/28/2011	6	7
TRUE	0.737068	FALSE	FALSE	Module No. 1	1:30:48 AM	4/28/2011	7	8
TRUE	0.749799	FALSE	FALSE	Module No. 1	1:30:48 AM	4/28/2011	8	9
TRUE	0.747253	FALSE	FALSE	Module No. 1	1:30:49 AM	4/28/2011	9	10
TRUE	0.747253	FALSE	FALSE	Module No. 1	1:30:49 AM	4/28/2011	10	11

Figure 25 LabVIEW Software Program Excel File

**2. Web connection**

It allows monitoring and controlling the LabVIEW software Program via internet from anywhere in the world, as shown in Figure 26.

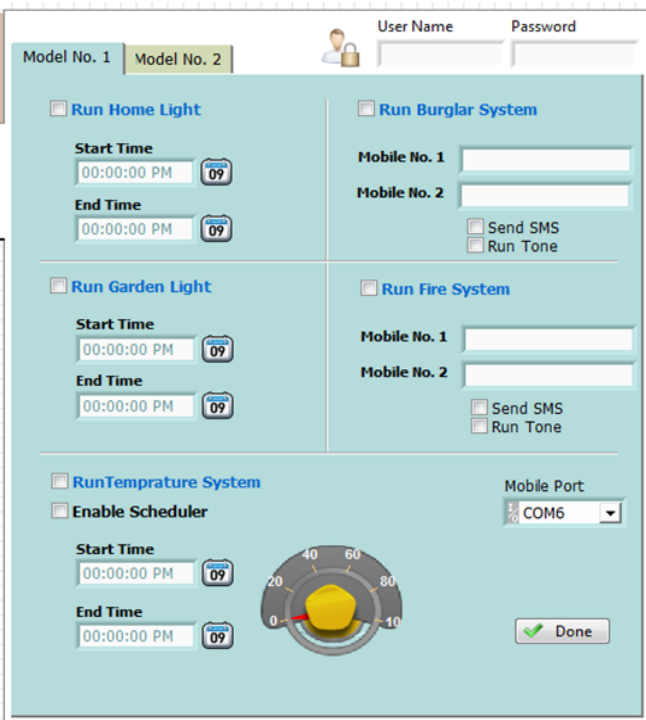

Figure 23 LabVIEW Software Program Setting Screen

**1. Login (Username and Password)**

It has two login; one for monitor access and the other for setting access as shown in Figure 24.

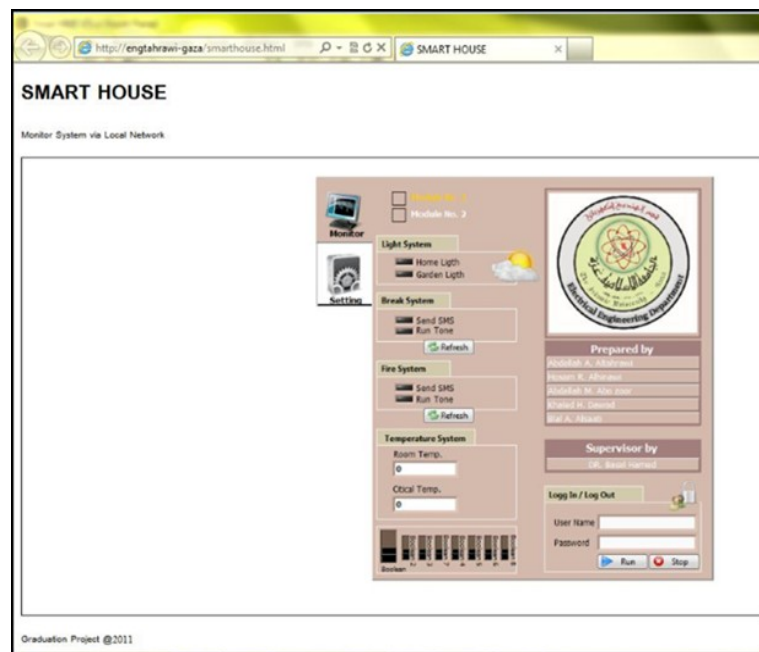

Figure 26 LabVIEW Software Program Web Connections



## V. CONCLUSION

The main objective of this Paper is to design and implement a control and monitor system for smart house. Smart house system consists of many systems that controlled by LabVIEW software as the main controlling system in this paper. Also, the smart house system was supported by remote control system as a sub controlling system. The system also is connected to the internet to monitor and control the house equipment's from anywhere in the world using LabVIEW.

## REFERENCES

- [1] <http://depts.washington.edu/dmgftp/publications/html/smarthouse98-mdg.html>
- [2] Sleman, A.; Alafandi, M.; Moeller, "Integration of Wireless Fieldbus and Wired Fieldbus for Health Monitoring"; R.; Consumer Electronics, 2009. ICCE '09. Digest of Technical Papers International Conference on 10-14 Jan. 2009 Page(s):1 - 2
- [3] Van Nguyen, T.; Jin Gook Kim; Deokjai Choi, "ISS: The Interactive Smart home Simulator," Advanced Communication Technology, 2009. ICACT 2009. 11th International Conference on , vol.03, no., pp.1828- 1833, 15-18 Feb. 2009
- [4] Escoffier, C.; Bourcier, J.; Lalanda, P.; Jianqi Yu, "Towards a Home Application Server," Consumer Communications and Networking Conference, 2008. CCNC 2008. 5th IEEE, vol., no., pp.321-325, 10-12 Jan. 2008.
- [5] Salvador, Z.; Jimeno, R.; Lafuente, A.; Larrea, M.; Abascal, J.; "Architecture for ubiquitous enviroments" Wireless And Mobile Computing, Networking And Communications, 2005. (WiMob'2005), IEEE International Conference on, Volume 4, 22-24 Aug. 2005 Page(s):90 - 97 Vol. 4.
- [6] Patricio, G.; Gomes, L., "Smart house monitoring and actuating system development using automatic code generation," Industrial Informatics, 2009. INDIN2009. 7th IEEE International Conference on, vol., no., pp.256-261, 23-26 June 2009
- [7] LabVIEW for Everyone: Graphical Programming Made Easy and Fun, Jeffrey Travis, Jim Kring, Third Edition. Prentice Hall Professional, 2007 ISBN-10: 0131856723.
- [8] <http://zone.ni.com/devzone/cda/pub/p/id/1141>
- [9] Chance Elliott, Vipin Vijayakumar, Wesley Zink, and Richard Hansen: National Instrument LabVIEW: A programming environment for laboratory automation and measurement, the association for Laboratory Automation, 2007.
- [10] Bitter, Rick, Taqi Mohiuddin, and Matt Nawrocki "LabVIEW Advanced Programming Techniques "Boca Raton: CRC Press LLC, 2001
- [11] LabVIEW User Manual, April 2003 Edition, National Instruments
- [12] [<http://www.ni.com/labview/>]

Dr. Basil Hamed is Associate Professor of Electrical Engineering Department, Islamic University of Gaza, Palestine, since 1999. He has Bachelor Degree in Electrical Engineering from New Mexico State University, NM. USA in the year of 1989, he received Master degree from University of New Orleans, La. USA in the year of 1992, and earned his PhD (Fuzzy Control System) from New Mexico State University, NM USA in the year 1999. He has 15 years of teaching experience and has published many papers in national and international journals. His fields of interest include Control Systems, Fuzzy Control, Simulation & Modeling, FPGA, Genetic Algorithm, SCADA System, Signal and Image Processing.