

# **SharpEye™**

## **Model 40/40M**

### **Multi IR Hydrocarbon and Hydrogen Flame Detector**

## **User Guide**



8200 Market Blvd, Chanhassen, MN 55317, USA

Phone: +1 (973) 239 8398

Website: [www.spectrex.net](http://www.spectrex.net) Email: [spectrex.csc.rmtna@emerson.com](mailto:spectrex.csc.rmtna@emerson.com)



## **Legal Notice**

The SPECTREX SharpEye Optical Flame Detector described in this document is the property of Rosemount.

No part of the hardware, software or documentation may be reproduced, transmitted, transcribed, stored in a retrieval system or translated into any language or computer language, in any form or by any means, without prior written permission of Rosemount.

While great efforts have been made to assure the accuracy and clarity of this document, Rosemount assumes no liability resulting from any omissions in this document, or from misuse of the information obtained herein. The information in this document has been carefully checked and is believed to be entirely reliable with all of the necessary information included. Rosemount reserves the right to make changes to any products described herein to improve reliability, function, or design, and reserves the right to revise this document and make changes from time to time in content hereof with no obligation to notify any persons of revisions or changes. Rosemount does not assume any liability arising out of the application or any use of any product or circuit described herein; neither does it convey license under its patent rights or the rights of others.

## **Warranty**

SPECTREX agrees to extend to Purchaser/Distributor a warranty on the SPECTREX supplied components of the SharpEye products. SPECTREX warrants to Purchaser/Distributor that the products are free from defects in materials and workmanship for a period of five (5) years, commencing with the date of delivery to Purchaser/Distributor. SPECTREX expressly excludes damage incurred in transit from the factory or other damage due to abuse, misuse, improper installation, or lack of maintenance or "Act of God" which are above and beyond its control. SPECTREX will, upon receipt of any defective product, transportation prepaid, repair or replace it at its sole discretion if found to have been defective when shipped. Said repair or replacement is SPECTREX'S sole liability under this warranty and SPECTREX'S liability shall be limited to repair or replacement of the component found defective and shall not include any liability for consequential or other damages. The customer is responsible for all freight charges and taxes due on shipments both ways. This warranty is exclusive of all other warranties express or implied.

TM40/40M Rev. (Af), February 2019



# Table of Contents

<b>Table of Contents .....</b>	<b>v</b>
<b>List of Figures .....</b>	<b>ix</b>
<b>List of Tables.....</b>	<b>x</b>
<b>1 About this Guide .....</b>	<b>11</b>
1.1 Release History.....	12
1.2 Glossary and Abbreviations .....	13
1.3 Notifications .....	14
<b>2 Product Overview .....</b>	<b>15</b>
2.1 Model and Types.....	16
2.2 Features and Benefits .....	17
2.3 Principles of Operation.....	18
2.3.1 Fire Detection Principle .....	18
2.3.2 Heated Optics.....	19
2.3.3 HART Protocol .....	19
2.3.4 RS-485 Modbus .....	19
2.3.5 Product Certification.....	20
2.3.6 ATEX, IECEx.....	20
2.4 Performance Considerations .....	22
2.4.1 Detection Sensitivity .....	22
2.4.2 Cone of Vision .....	23
2.4.3 False Alarm Prevention .....	26
2.4.4 Visual Indicators .....	27
2.4.5 Output Signals.....	27
2.4.6 Detector Status .....	28
2.4.7 Auxiliary Relay as End-of-Line .....	30
2.5 Internal Detector Tests .....	30
2.5.1 Continuous Feature Test .....	30
2.5.2 Built-In-Test (BIT) .....	31
<b>3 Installing the Detector .....</b>	<b>35</b>
3.1 General Guidelines .....	35
3.1.1 Sensitivity.....	35
3.1.2 Wiring .....	35
3.1.3 Spacing and Location .....	35

3.1.4	Environment .....	35
3.1.5	Aiming the Detector .....	35
3.2	Unpacking the Product.....	36
3.2.1	Checking the Product Type.....	36
3.3	Required Tools.....	37
3.4	Certification Instructions .....	37
3.4.1	Special Instructions for Safe Use.....	37
3.4.2	General Instructions.....	38
3.5	Installation Cables .....	39
3.5.1	Conduit Installation .....	39
3.6	Installing the Tilt Mount .....	40
3.6.1	Tilt Mount Assembly .....	41
3.7	Connecting the Detector .....	42
3.7.1	Verifying the Detector Wiring .....	44
3.8	Configuring Your Detector .....	45
3.8.1	Sensitivity.....	45
3.8.2	Alarm Delay .....	46
3.8.3	Address Setup .....	46
3.8.4	Function Setup .....	46
3.8.5	Heated Optics.....	47
<b>4</b>	<b>Operating the Detector .....</b>	<b>49</b>
4.1	Powering Up.....	49
4.2	Safety Precautions .....	49
4.2.1	Default Functions Settings .....	50
4.3	Testing Procedures.....	51
4.3.1	Automatic BIT Test .....	51
4.3.2	Manual BIT Test.....	51
4.3.3	Testing with Flame Simulator Model FS-1400 .....	51
<b>5</b>	<b>Maintenance and Troubleshooting .....</b>	<b>53</b>
5.1	Maintenance.....	53
5.1.1	General Procedures .....	53
5.1.2	Periodic Procedures .....	53
5.1.3	Keeping Maintenance Records .....	54
5.2	Troubleshooting.....	54
<b>Appendix A: Specifications .....</b>		<b>55</b>
A.1	Technical Specifications .....	55

A.2	Electrical Specifications.....	56
A.2.1	Electrical Input Protection .....	56
A.3	Outputs .....	56
A.3.1	Electrical Interface .....	56
A.3.2	Electrical Outputs.....	57
A.3.3	Heated Optics.....	58
A.4	Approvals.....	59
A.4.1	Hazardous Area Approvals .....	59
A.4.2	Functional Approvals .....	59
A.5	Mechanical Specifications .....	59
A.5.1	Enclosure.....	60
A.5.2	Water and Dust Tight .....	60
A.5.3	Electronic Modules .....	60
A.5.4	Electrical Connection (2 entries) .....	60
A.5.5	Dimensions .....	60
A.5.6	Weight .....	60
A.6	Environmental Specifications .....	60
A.6.1	High Temperature.....	60
A.6.2	Low Temperature.....	60
A.6.3	Humidity.....	60
A.6.4	Salt Fog.....	61
A.6.5	Dust.....	61
A.6.6	Vibration.....	61
A.6.7	Mechanical Shock.....	61
A.6.8	Electromagnetic Compatibility (EMC) .....	61
<b>Appendix B:</b>	<b>Wiring Instructions.....</b>	<b>63</b>
B.1	General Instructions for Electrical Wiring.....	63
B.2	Calculation Formula.....	63
B.3	Typical Wiring Configurations .....	64
<b>Appendix C:</b>	<b>RS-485 Communication Network .....</b>	<b>69</b>
C.1	RS-485 Overview .....	69
<b>Appendix D:</b>	<b>Accessories .....</b>	<b>71</b>
D.1	Flame Simulator FS-1400.....	71
D.1.1	Ordering Information.....	71
D.1.2	Unpacking.....	72
D.1.3	Operating Instructions.....	72

D.1.4	Range .....	73
D.1.5	Charging the Battery .....	73
D.1.6	Battery Replacement .....	74
D.2	Technical Specifications .....	75
D.2.1	General .....	75
D.2.2	Electrical.....	75
D.2.3	Physical .....	75
D.2.4	EMI Compatibility.....	76
D.3	Tilt Mount .....	77
D.4	Duct Mount .....	78
D.5	Weather Cover .....	79
D.6	Air Shield.....	80
<b>Appendix E:</b>	<b>SIL-2 Features .....</b>	<b>81</b>
E.1	40/40M Flame Detector .....	81
E.1.1	Safety Relevant Parameters .....	81
E.1.2	Guidelines for Configuring, Installing, Operating, and Service.....	81
<b>Appendix F:</b>	<b>End of Line Resistor .....</b>	<b>84</b>
<b>Technical Support</b>	<b>.....</b>	<b>88</b>



# List of Figures

Figure 1: Vertical and Horizontal Field of View for Gasoline.....	24
Figure 2: Horizontal Fields of View for Hydrogen .....	24
Figure 3: Vertical Field of View for Hydrogen .....	25
Figure 4: Indicator LED .....	27
Figure 5: Detector with Tilt Mount .....	40
Figure 6: Tilt Mount Assembly.....	41
Figure 7: Tilt Mount Assembly (dimensions in millimeters and inches) .....	41
Figure 8: Detector with Cover Removed .....	43
Figure 9: Wiring Terminals .....	65
Figure 10: Typical Wiring for 4 Wire Controllers (Using Option 1 or 2 Wiring).....	66
Figure 11: 0–20mA Wiring Option 1 (Sink 4-Wire) - Default .....	66
Figure 12: 0–20mA Wiring Option 1 (Converted to Source 3-Wire) .....	67
Figure 13: 0–20mA Wiring Option 1 (Non-isolated Sink 3-Wire) .....	67
Figure 14: 0–20mA Wiring Option 2 and 3 (Source 3-Wire available with the HART Protocol) .....	68
Figure 15: RS-485 Networking .....	69
Figure 16: Flame Simulator FS-1400 .....	71
Figure 17: Flame Simulator Battery Replacement .....	73
Figure 18: Tilt Mount .....	77
Figure 19: Duct Mount .....	78
Figure 20: Weather Cover .....	79
Figure 21: Air Shield.....	80
Figure 22: End of Line Resistor Assembly .....	84

# List of Tables

Table 1: Wiring Options .....	17
Table 2: Sensitivity Range Levels .....	22
Table 3: Fuel Sensitivity Ranges.....	23
Table 4: Immunity to False Alarm Sources .....	26
Table 5: Welding Immunity Distance .....	26
Table 6: LED Indications .....	27
Table 7: Available Output Types.....	28
Table 8: Detector Status .....	28
Table 9: Output Signals Versus Detector State.....	29
Table 10: Results of a Successful BIT.....	31
Table 11: Results of an Unsuccessful BIT .....	32
Table 12: Results of a Successful Manual BIT.....	32
Table 13: Results of an Unsuccessful Manual BIT .....	32
Table 14: Tools .....	37
Table 15: Model 40/40M Wiring Options.....	44
Table 16: Sensitivity Settings .....	45
Table 17: Functions .....	46
Table 18: Default Function Values .....	50
Table 19: Results of Successful Flame Simulator Test .....	52
Table 20: Troubleshooting Table .....	54
Table 21: Electrical Specifications.....	56
Table 22: Contact Ratings .....	57
Table 23: 20mA Current Output.....	57
Table 24: Electromagnetic Compatibility (EMC) .....	61
Table 25: Maximum DC Resistance at 68°F/20°C for Copper Wire .....	63
Table 26: Wiring Length (ft/m) .....	63
Table 27: Wiring Connections .....	65
Table 28: Sensitivity Ranges.....	73
Table 29: Immunity Tests .....	76
Table 30: Emission Tests.....	76

# 1 About this Guide

This guide describes the SharpEye Model 40/40M Multi IR Flame Detector and its features and provides instructions on how to install, operate, and maintain the detector.

**Note:**

This user guide should be read carefully by all individuals who have or will have responsibility for using, maintaining, or servicing the product.

---

This guide includes the following chapters and appendices:

- **Chapter 1, About this Guide**, details the layout of the guide, includes the release history, a glossary and abbreviations, and explains how notifications are used in the guide.
- **Chapter 2, Product Overview**, provides a general overview of the product, principles of operation, and performance considerations.
- **Chapter 3, Installing the Detector**, describes how to install the detector including preparations before installation, wiring, and mode settings.
- **Chapter 4, Operating the Detector**, describes how to power-up and test the detector. The chapter also lists safety precautions you should take when operating the detector.
- **Chapter 5, Maintenance and Troubleshooting**, describes basic maintenance, troubleshooting, and support procedures.
- **Appendix A, Specifications**, lists the detectors' technical and other specifications.
- **Appendix B, Wiring Instructions**, lists the wiring instructions for connecting the detector and also provides examples of typical wiring configurations.
- **Appendix C, RS-485 Communication Network**, provides an overview of the RS-485 communications network.
- **Appendix D, Accessories**, describes the accessories available for the detector.
- **Appendix E, SIL-2 Features**, describes the special conditions for compliance with EN 61508 for SIL-2 requirements according to TÜV.
- **Appendix F, End of Line Resistor**, describes the option of adding an end of line resistor.

## 1.1 Release History

Rev	Date	Revision History	Prepared by	Approved by
0	July 2008	First Release	Ian Buchanan	Eric Zinn
1	September 2008	Second Release	Ian Buchanan	Eric Zinn
2	July 2010	Third Release	Ian Buchanan	Eric Zinn
3	August 2010	Fourth Release	Ian Buchanan	Eric Zinn
4	November 2010	Fifth Release	Ian Buchanan	Eric Zinn
5	February 2013	Sixth Release	Ian Buchanan	Eric Zinn
6	July 2013	Seventh Release	Ian Buchanan	Eric Zinn
7	February 2015	Eighth Release	Ian Buchanan	Eric Zinn
8	June 2015	Ninth Release	Ian Buchanan	Eric Zinn
9	August 2015	Tenth Release	Ian Buchanan	Eric Zinn
10	January 2016	Eleventh Release	Ian Buchanan	Eric Zinn
11	July 2016	Twelfth Release	Ian Buchanan	Eric Zinn
12	October 2016	Thirteenth Release	Jay Cooley	Ian Buchanan
13	January 2017	Fourteenth Release	Jay Cooley	Ian Buchanan
14	February 2017	Fifteenth Release	Jay Cooley	Ian Buchanan
Ae	March 2018	Sixteenth Release	Michal Heller	Udi Tzuri
Af	February 2019	Seventeenth Release	Michal Heller	Udi Tzuri

## 1.2 Glossary and Abbreviations

<b>Abbreviation/Term</b>	<b>Meaning</b>
Analog Video	Video values are represented by a scaled signal
ATEX	Atmosphere Explosives
AWG	American Wire Gauge
BIT	Built-In-Test
CMOS	Complementary Metal-Oxide Semiconductor image sensor
Digital Video	Each component is represented by a number representing a discrete quantization
DSP	Digital Signal Processing
EMC	Electromagnetic Compatibility
EMI	Electromagnetic Interference
EOL	End of Line
FOV	Field of View
HART	Highway Addressable Remote Transducer – communications protocol
IAD	Immune at Any Distance
IECEX	International Electro-Technical Commission Explosion
IP	Internet Protocol
IPA	Isopropyl Alcohol
IR	Infrared
IR3	Refers to the 3 IR sensors in the VID
JP5	Jet Fuel
LED	Light Emitting Diode
MODBUS	Serial communications protocol using Master-Slave messaging
N/A	Not Applicable
N.C.	Normally Closed
NFPA	National Fire Protection Association
N.O.	Normally Open
NPT	National Pipe Thread
NTSC	National Television System Committee (a color encoding system)
PAL	Phase Alternation by Line (a color encoding system)

Abbreviation/Term	Meaning
P/N	Part Number
RFI	Radio Frequency Interference
RTSP	Real Time Streaming Protocol
SIL	Safety Integrity Level
UNC	Unified Coarse Thread
VAC	Volts Alternating Current

## 1.3 Notifications

This section explains and exemplifies the usage of warnings, cautions, and notes throughout this guide:



**Warning:**

This indicates a potentially hazardous situation that could result in serious injury and/or major damage to the equipment.

---



**Caution:**

This indicates a situation that could result in minor injury and/or damage to the equipment.

---



**Note:**

This provides supplementary information, emphasizes a point or procedure, or gives a tip to facilitate operation.

---

## 2 Product Overview

The 40/40M Multi IR Flame Detector is specifically designed for detection of hydrocarbon and hydrogen flames. It detects hydrocarbon-based fuel and gas fires at long distances with the highest immunity to false alarms. The 40/40M can detect a gasoline pan fire at 215 ft/65m or a hydrogen flame at 100 ft/30m in less than 5 seconds.

All 40/40 series detectors include a heated optical window for improved performance in ice, snow, and condensation conditions.

Detection performance can be easily adapted to all environments, applications, and requirements, by changing the detector's configuration parameters. Adjusting these parameters, as well as performing other maintenance and monitoring tasks, is possible by means of RS-485-based Modbus communication or HART communication (in models with 0–20mA output).

The detector enclosure is ATEX certified Exd flameproof with an integral, segregated, rear, Exe terminal compartment (avoiding exposure of the sensors and electronics to the surrounding environment). Hence the combined approval:

Ex II 2G D

Ex db eb op is IIC T4 Gb

Ex tb op is IIIC T96°C Db

( $-55^{\circ}\text{C} \leq T_a \leq +75^{\circ}\text{C}$ )

or

Ex II 2G D

Ex db eb op is IIC T4 Gb

Ex tb op is IIIC T106°C Db

( $-55^{\circ}\text{C} \leq T_a \leq +85^{\circ}\text{C}$ )

The SharpEye 40/40 detector is designed to operate as a stand-alone unit directly connected to an alarm system or an automatic fire extinguishing system. The detector can also be a part of a more complex system, where many detectors and other devices are integrated through a common control unit.



**Warning:**

The detector is not field-repairable due to the meticulous alignment and calibration of the sensors and the respective circuits. Do not attempt to modify or repair the internal circuits or change their settings, as this will impair the system's performance and void the SPECTREX product warranty.

---

## 2.1 Model and Types

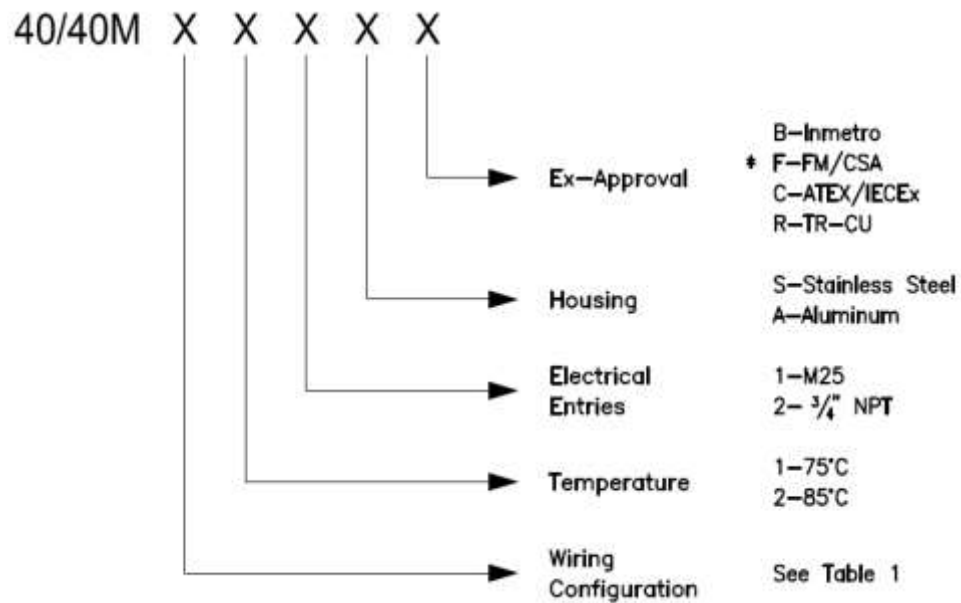
The 40/40M Flame Detector is provided in various configurations depending on:

- Wiring options
- Temperature ranges
- Type of cable entries
- Housing material type
- Required approval

The configuration detail is included in the product part number on the product label and takes the form: 40/40M-XXXXX, where XXXXX defines the model according to the above requirements.

To modify the default or pre-ordered configuration and perform maintenance tasks, please refer to the *HART Protocol TM777030*, the *RS-485 Manual TM777050* or *TM777070*.

The P/Ns are defined as:



\* Aluminum housing is not available in the FM version.



Table 1 describes the wiring options in detail.

**Table 1: Wiring Options**

Wiring Option				Connections Provided			
1	Power	Manual BIT	Fault Relay N.C.	Alarm Relay N.O.	0–20mA Sink	RS-485	HART
2	Power	Manual BIT	Fault Relay N.C.	Alarm Relay N.O., N.C.	0–20mA Source	RS-485	HART
3	Power	Manual BIT	Fault Relay N.O.	Alarm Relay N.O., N.C.	0–20mA Source	RS-485	HART
4	Power	Manual BIT	Fault Relay N.C.	Alarm Relay N.O.	Auxiliary N.O.	RS-485	-
5	Power	Manual BIT	Fault Relay N.O.	Alarm Relay N.O.	Auxiliary N.O.	RS-485	-

Wiring option 1 is the default. The mA “Sink” output can be altered to “Source” type, with a link between terminals 1 and 8. No other wiring options can be changed onsite.

For example, product number 40/40M-321SC has the following options:

- **Wiring Option:** 3 (Power, Manual BIT, RS-485, 0–20mA [Source] with the HART protocol, fault relay [N.O.], alarm relay [N.O., N.C.] )
- **Temperature Range:** 2 (85°C)
- **Cable Entry:** 1 (M25)
- **Housing:** S (Stainless steel)
- **Approval:** C (ATEX, IECEx)



**Note:**

Check your specific part numbers against the information in *Checking the Product Type* on page 36.

## 2.2 Features and Benefits

- Detects Hydrocarbons and Hydrogen Flames.
- Detection Range: Up to 215ft/65m for a 1ft<sup>2</sup>/0.1m<sup>2</sup> n-heptane fire.
- Ultra-High Immunity to False Alarms: See Table 4 on page 26.

- Advanced Digital Processing of the Dynamic Characteristics of Fire: Flickering, threshold correlation and ratio.
- Multi IR Channels: Between 2–5 microns.
- Field Programmable Sensitivity: 4 ranges to avoid zone crossover.
- Built-In-Test (BIT): Manual and Automatic (see *Built-In-Test (BIT)* on page 31).
- Heated Window: Prevents effects of ice, snow, and condensation.
- Electrical Interface:
- Dry contact relays
- Communication network RS-485
- 0–20mA output
- HART Protocol: Communication protocol (see *HART Protocol* on page 19).
- Exde: Integral junction box for easy wiring.
- SIL-2: TÜV approved.
- Hazardous Area Certification: ATEX, IECEx, FM, CSA.
- Functionality Approval:
- EN54-10 approved by VdS
- FM approved per FM3260
- Accessories are approved as part of ATEX and IECEx approval.

## 2.3 Principles of Operation

This section describes the 40/40M principles of operation and includes:

### 2.3.1 Fire Detection Principle

The SharpEye 40/40M Detector is designed to detect hydrocarbon flames that produce CO<sub>2</sub> in their combustion process and non-hydrocarbon flames that produce mainly water vapor (H<sub>2</sub>O) from inorganic fuels, for example, hydrogen, ammonia, hydrofluoric acid, hydrochloric acid and so on.

The detector's principle of operation is based on the patented spectral analysis technology that identifies the IR spectral signature of fire products, i.e. the hot CO<sub>2</sub> spectral emission band at wavelengths of 4.2–4.7µm and the hot water (H<sub>2</sub>O) spectral emission band at wavelengths of 2.7–3.0µm. Additional spectral bands (above and below these bands) are analyzed for background interferences.

The spectral analysis incorporates several detection algorithms, according to several types of fire events, taking into account simultaneous detection of both CO<sub>2</sub> and H<sub>2</sub>O peaks, or only one of them, as well as flickering analysis at frequencies typical to these flames. Only when all the parameters of the spectral analysis and the flickering analysis meet the predetermined values, is a fire condition identified and the fire alarm is issued.

When exposed to non-fire radiation sources, these parameters do not identify a fire condition and the detector does not react.

### 2.3.2 Heated Optics

The SharpEye 40/40 Flame Detector uses heated optics. The heater increases the temperature of the optical surface by 5–8°F / ~3–5°C above the ambient temperature to improve performance in ice, condensation, and snow conditions.

The heated optics can be set to one of the following:

- Not operated.
- On continuously.
- Automatic, per temperature change (default): you can define the start temperature below which the window is heated. (The default is 41°F/5°C.) This temperature can be defined from 32°F/0°C to 86°F/30°C. The heating stops when the temperature is 27°F/15°C above the start temperature.

For more information, see *Configuring Your Detector* on page 45.

### 2.3.3 HART Protocol

The SharpEye 40/40 Flame Detectors use the HART protocol.

HART Communication is a bi-directional industrial field communication protocol used to communicate between intelligent field instruments and host systems. HART is the global standard for smart process instrumentation and the majority of smart field devices installed in plants worldwide are HART-enabled. HART is available in wiring options 1, 2, and 3 (see Table 1, page 17).

HART technology is easy to use and very reliable.

Through the HART connection, you are able to perform:

- Detector setup
- Detector troubleshooting
- Detector health and status

For more details, refer to the *HART Manual TM777030*.

### 2.3.4 RS-485 Modbus

For more advanced communications, the 40/40M detector has an RS 485 Modbus-compatible output that provides data communication from a network (up to 247 detectors) to a host computer or universal controller for central monitoring. This feature allows for reduced installation costs, easy maintenance, and local or remote diagnostic tools.

## 2.3.5 Product Certification

The 40/40M Flame Detectors have the following certifications:

- ATEX, IECEx, page 20
- FM, CSA, page 20
- SIL-2 (TÜV), page 21
- EN54-10, page 21
- Inmetro (UL), page 21
- TR CU/EAC, page 21

## 2.3.6 ATEX, IECEx

The 40/40M Flame Detector is certified to:

- ATEX per SIRA 07ATEX1250X and IECEx per IECEx SIR 07.0085X

Ex II 2G D

Ex db eb op is IIC T4 Gb

Ex tb op is IIIC T96°C Db

(-55°C ≤ Ta ≤ +75°C)

Or

Ex II 2G D

Ex db eb op is IIC T4 Gb

Ex tb op is IIIC T106°C Db

(-55°C ≤ Ta ≤ +85°C)

The accessories, Tilt Mount P/N 40/40-001, Weather Cover P/N 777163 and P/N 777268, Duct Mount P/N 777670 and Air Shield P/N 777650 are included in the approval.

This product is suitable for use in hazardous zones 1 and 2 with IIC gas group vapors present, and zones 21 and 22 with IIIC dust type present.

### 2.3.6.1 FM, CSA

The 40/40M Flame Detector is certified for FM and CSA Explosion Proof and Functionality per FM3260:

- Class I, Division 1, Groups B, C, and D.
- Dust Ignition Proof – Class II/III Division 1, Groups E, F, and G.
- Ingress Protection – IP67, IP66, NEMA 250 Type 6P.
- For more details see FM Report Project ID3029553 and CSA Report No. 2451134.

### 2.3.6.2 SIL-2 (TÜV)

The 40/40M Flame Detector is certified for the SIL-2 requirement per IEC 61508.4, Chapter 3.5.12.

The alert condition according to SIL-2 can be implemented by:

- Alert signal via 0–20mA current loop.
- Or
- Alert signal via alarm relay and fault relay.
  - For more details and guidelines for configuring, installing, operating, and service, see *SIL-2 Features* on page 81 and TÜV Report No. 968/EZ 348.

### 2.3.6.3 EN54-10

The 40/40M Flame Detector is certified to EN54-10 and CPD.

- The detector is listed as Class 1 for sensitivity settings 15, 30, 45 and 60 and Class 2 for sensitivity settings 15, 30, 45 and 60.
- The detector has been tested and approved per EN54-10 by VdS.
- This test includes a functional test, environmental test, EMI/EMC test, and software check.
- For more details see VdS Reports Numbers BMA 12117 and BMA 12118.

### 2.3.6.4 Inmetro (UL)

The 40/40M Flame Detector is in compliance with the standards ABNT NBR IEC 60079-0, ABNT NBR IEC 60079-1, ABNT NBR IEC 60079-7, ABNT NBR IEC 60079-18, ABNT NBR IEC 60079-31, and INMETRO decree No. 179 as of May 18th, 2010. Further details may be found on Certificate of Compliance No. UL-BR 16.065XX.

### 2.3.6.5 TR CU/EAC

The 40/40M Flame Detector is in compliance with the standard TR CU 012/2011 per:

1 Ex db eb op is IIC T4 Gb X

Ex tb op is IIIC T96°C Db X

(-55°C ≤ Ta ≤ +75°C)

Or

1 Ex db eb op is IIC T4 Gb X

Ex tb op is IIIC T106°C Db X

(-55°C ≤ Ta ≤ +85°C)

Or

1 Ex db eb mb op is IIC T4 Gb X

Ex tb op is IIIC T98°C Db X

(-55°C ≤ Ta ≤ +75°C)

For more details, see TR CU certificate No. TC RU C- US.MIO62.B.05536.

## 2.4 Performance Considerations

This section describes performance aspects of the 40/40M.

### 2.4.1 Detection Sensitivity

Detection sensitivity is the maximum distance at which the detector reliably detects a specific size of fire and typical type of fuel (standard fire).

#### 2.4.1.1 Standard Fire

Defined as a 1ft<sup>2</sup>/0.1m<sup>2</sup> n-heptane pan fire, with maximum wind speed of 6.5ft/sec / 2m/sec.

#### 2.4.1.2 Sensitivity Ranges

The detector has 4 user-selectable sensitivity ranges. For each range there are 2 response levels.

- Warning (Pre-alarm)
- Alarm

The detection distance for the Warning level, is approximately 10% higher than for the Alarm distance.

Alarm response times for a standard fire at a specified range are shown in Table 2.

**Table 2: Sensitivity Range Levels**

Level	Response Time (sec)	Sensitivity Range ft/m (for 1ft <sup>2</sup> /0.1m <sup>2</sup> n-heptane pan fire)
1	3	50/15
2 (default)	5	100/30
3	8	150/45
4	10	215/65

For some typical ambient conditions the Zeta parameter as defined in NFPA 72 for the detector is 0.005 (1/meter).



**Note:**

Zeta parameters may vary significantly with changes in temperature, air pressure, humidity, visibility conditions, etc.

#### 2.4.1.3 Other Fuels

The detector reacts to other types of fire as follows:

- The baseline fire refers to n-heptane 1ft<sup>2</sup>/0.1m<sup>2</sup> and is defined as 100% sensitivity.

- For fuel fire – standard pan fire size: 1ft<sup>2</sup>/0.1m<sup>2</sup>.
- For gas flame – 30"/0.75m high, 10"/0.25m width plume fire.
- Maximum Response Time: 10 sec.

**Table 3: Fuel Sensitivity Ranges**

Type of Fuel	Percent of Max. Distance at Each Sensitivity Range	Max. Distance (ft/m)
Gasoline	100%	215/65
N-Heptane	100%	215/65
JP5	70%	150/45
Kerosene	70%	150/45
Diesel Fuel	70%	150/45
Ethanol 95%	60%	135/40
IPA	60%	135/40
Methanol	55%	115/35
Methane <sup>1</sup>	70%	150/45
LPG <sup>1</sup>	70%	150/45
Paper	38%	82/25
Polypropylene	55%	115/35
Hydrogen <sup>1</sup>	50%	125/38
Silane <sup>2</sup>	3%	7/2
Ammonia <sup>2</sup>	27%	60/18

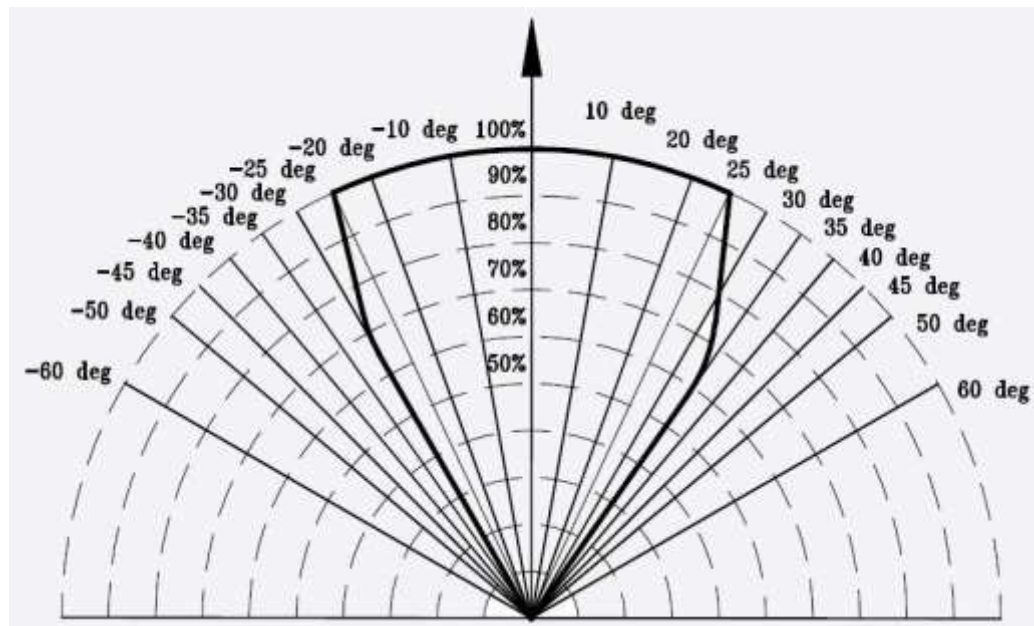
<sup>1</sup> 30"/0.75m high, 10"/0.25m width plume fire

<sup>2</sup> 20"/0.5m high, 8"/0.2m width plume fire

## 2.4.2 Cone of Vision

### 2.4.2.1 Gasoline

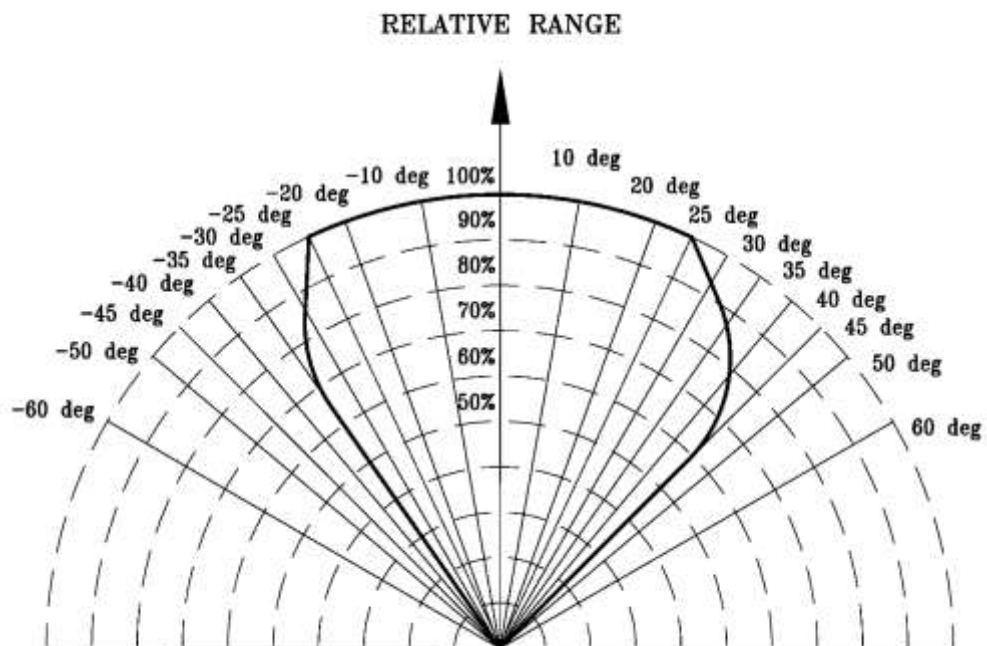
- Horizontal: 80°
- Vertical: 80°



**Figure 1: Vertical and Horizontal Field of View for Gasoline**

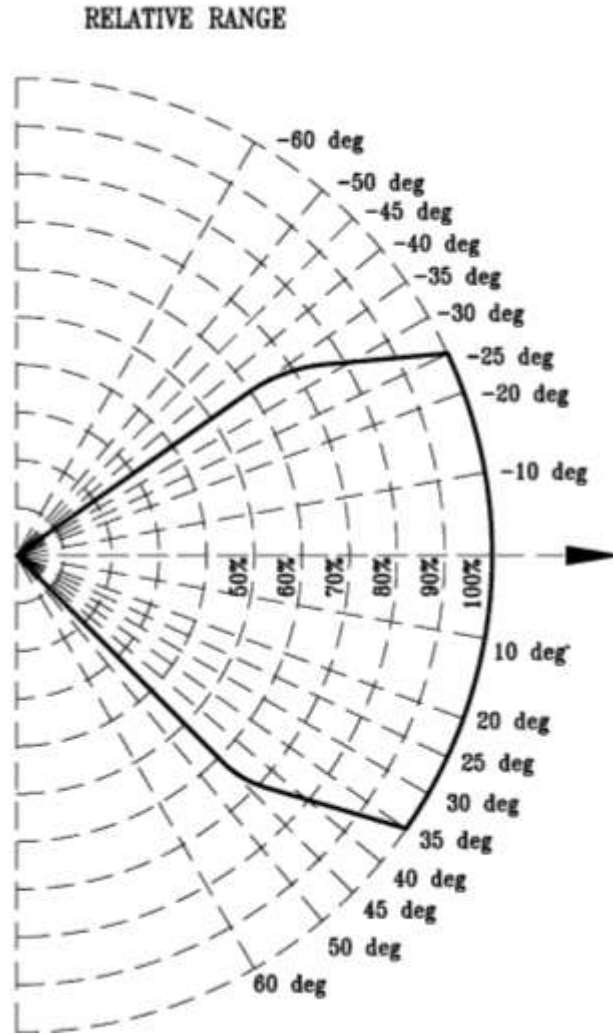
### 2.4.2.2 Hydrogen

- Horizontal: 70°
- Vertical: 80°



**Figure 2: Horizontal Fields of View for Hydrogen**





**Figure 3: Vertical Field of View for Hydrogen**

### 2.4.3 False Alarm Prevention

To prevent false alarms, the detector will not alarm or react to the radiation sources specified in Table 4.

**Table 4: Immunity to False Alarm Sources**

Radiation Source <sup>1</sup>	Immunity Distance ft/ m
Indirect or reflected sunlight	IAD <sup>2</sup>
Vehicle headlights (low beam) conforming to MS53023-1	IAD
Incandescent frosted glass light, 300W	IAD
Fluorescent light with white enamel reflector, standard office or shop, 70W (or 2 35W)	IAD
Electric arc [12mm / <sup>15</sup> / <sub>32</sub> " gap at 4000V alternating current, 60Hz]	IAD
Arc welding [6mm / <sup>5</sup> / <sub>16</sub> " rod; 210A]	See Table 5
Ambient light extremes (darkness to bright light with snow, water, rain, desert glare, and fog)	IAD
Bright colored clothing, including red and safety orange	IAD
Electronic flash (180 watt-seconds minimum output)	IAD
Movie light, 625W quartz DWY lamp (Sylvania S.G.-55 or equivalent)	>6.5/2
Blue-green dome light conforming to M251073-1	IAD
Flashlight (MX 991/U)	IAD
Radiation heater, 3000W	>3/1
Radiation heater, 1000W with fan	IAD
Quartz lamp (1000W)	>3/1
Mercury vapor lamp	IAD
Grinding metal	IAD
Lit cigar	>1/0.3
Lit cigarette	>1/0.3
Match, wood, stick including flare up	>13/4

<sup>1</sup> All sources are chopped from 0–20Hz.

<sup>2</sup> IAD = Immune at Any Distance.

**Table 5: Welding Immunity Distance**

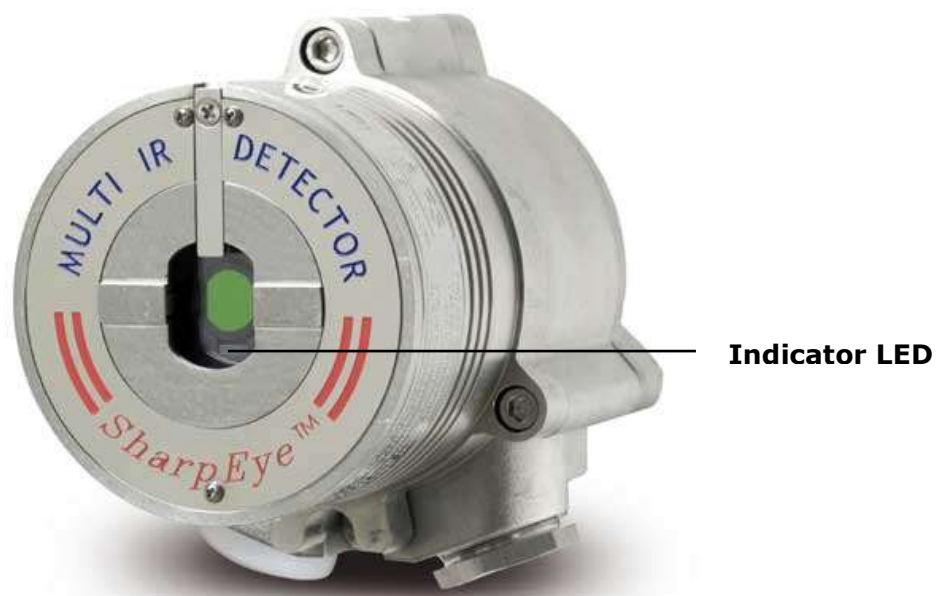
Sensitivity Setting	Detection Range (ft/m)	Immunity Distance (ft/m)
1	50/15	>6/2
2	100/30	>12/4
3	150/45	>17/6
4	215/65	>25/7.5

## 2.4.4 Visual Indicators

One 3-color LED indicator is located inside the detector window, as shown in Figure 4. The detector statuses are listed in Table 6.

**Table 6: LED Indications**

Detector Status	LED color	LED mode
Fault, BIT Fault	Yellow	4Hz - flashing
Normal	Green	1Hz - flashing
Warning	Red	2Hz - flashing
Alarm	Red	Steady



**Figure 4: Indicator LED**

## 2.4.5 Output Signals

Outputs are available according to the default configuration or the wiring options selected for the 40/40M detector. Determine the outputs for your model according to Table 7.

The detector incorporates several types of output suitable to different control systems:

- 0–20mA (stepped) with HART
- Relays (alarm, fault, auxiliary)
- RS-485 Modbus

**Table 7: Available Output Types**

Output Type	Version	Detector Status
Alarm Relay	40/40M – Options 1XXXX, 4XXXX, and 5XXXX	The relay is N.O.
	40/40M – Options 2XXXX and 3XXXX	The relay is N.O. and N.C.
Auxiliary Relay	40/40M – Options 4XXXX and 5XXXX	The relay is N.O.
Fault Relay	40/40M – Options 1XXXX, 2XXXX, and 4XXXX	The relay is N.C. energized
	40/40M – Options 3XXXX and 5XXXX	The relay is N.O. energized
0–20mA Current Output	40/40M – Option 1XXXX	Sink with the HART protocol, (can be changed to Source – see Figure 11, Figure 12, and Figure 13)
	40/40M – Options 2XXXX and 3XXXX	Source with the HART protocol
RS-485	All versions	Modbus protocol

## 2.4.6 Detector Status

The possible detector function statuses are listed in Table 8. A more detailed fault analysis can be seen via HART or RS-485.

**Table 8: Detector Status**

Status	Description
Normal	Normal operation.
BIT	Built-In-Test being performed.
Warning	Fire detected – changed to Warning (pre-alarm state).
Alarm	Fire detected – changed to Fire Alarm state.
Latched Alarm (Optional)	The alarm outputs remain latched on following detection of a fire that has already been extinguished.
BIT Fault	A fault is detected during BIT sequence or other electric failure. The detector will continue to detect for fire.
Fault	A fault is detected when the power supply is too low, due to a software fault, or due to an electrical failure. The detector will NOT detect fire in this condition.

In each state, the detector activates different outputs, as specified in Table 9.

**Table 9: Output Signals Versus Detector State**

Detector State	LED Indicator	LED Mode	Alarm Relay	Auxiliary Relay	Fault Relay	mA output
Normal	Green	1Hz	Off	Off	On	4mA
Warning	Red	2Hz	Off	On <sup>4</sup>	On	16mA
Alarm <sup>1</sup>	Red	Constant	On	On	On	20mA
Latched <sup>2</sup>	Red	Constant	On	Off	On	20mA
				On <sup>4</sup>	On	20mA
BIT Fault <sup>3</sup>	Yellow	4Hz	Off	Off	Off	2mA
Warning at BIT Fault	Red	2Hz	Off	On <sup>4</sup>	Off	16mA
Alarm at BIT Fault	Red	Constant	On	On	Off	20mA
Fault	Yellow	4Hz	Off	Off	Off	0mA

<sup>1</sup> The alarm outputs are activated while alarm conditions exist and will stop approximately 5 seconds after the fire is no longer detected.

<sup>2</sup> The alarm state can be optionally latched via programmed function (default is non-latched).

<sup>3</sup> The detector will remain in BIT Fault state until it has passed a successful BIT.

<sup>4</sup> The auxiliary relay can be activated at the warning level or alarm level, depending on programmed function.



**Note:**

The outputs depend on the wiring options.

### 2.4.6.1 Optional Latching

Alarms are set as non-latching by default. However, the detector includes a latched alarm output capability, which operates according to the programmed function.

If selected, upon detection of a fire, the detection signal is latched until a manual reset is performed (disconnecting the power supply or performing a manual BIT (see *Manual BIT* on page 32)).

Latching affects the alarm relay, 0–20mA output, the alarm LED (the auxiliary relay will be latched only when the programmable function **auxiliary relay** is set to **YES**).

**Notes:**

- The auxiliary relay is available only in Models with suffix – 4XXXX and 5XXXX
- The 0–20mA is available only in Models with suffix – 1XXXX, 2XXXX, and 3XXXX

## 2.4.7 Auxiliary Relay as End-of-Line

The auxiliary relay can be used as End-of-Line in models with suffix–4XXXX and 5XXXX only. In this case, the auxiliary relay is active as long as the detector is powered.

## 2.5 Internal Detector Tests

The detector performs 2 types of self-tests:

- Continuous Feature Test, page 30
- Built-In-Test (BIT), page 31

### 2.5.1 Continuous Feature Test

During normal operation, the detector tests itself continuously and indicates a fault if a failure is found. This type of test complies with SIL-2 requirements.

The detector continuously tests:

- Input voltage level
- All internal regulator voltage levels
- Voltage level status of sensor and sensor circuitry for noise or disconnection in the electronic circuitry
- 0–20mA level output
- Relays and heater operation
- Processor watchdog
- Software
- Memory
- Oscillator frequency

#### **Response to Fault Indication**

If a failure is found, the detector indicates by:

- Fault relay:
  - Opens in wiring options 1, 2, and 4
  - Closes in wiring options 3 and 5
- 0–20mA: indicates fault (0mA or 2mA) in wiring options 1, 2, and 3
- LED – Yellow flashes (4Hz)
- Correcting the fault

The fault indications remain until the detector's power is removed. The fault indications return if the fault is still found when power is restored.

## 2.5.2 Built-In-Test (BIT)

The detector's Built-In-Test (BIT) also checks the following:

- Electronic circuitry
- Sensors
- Window cleanliness

The detector can be set to perform the BIT in the following modes:

- Automatically and manually
- Manually only



**Note:**

In Manual BIT, the outputs may also be tested and Control System "inhibit" should be applied if this could initiate other systems.

### 2.5.2.1 How the BIT Operates

- The detector's status remains unchanged if the result of a BIT is the same as the current status (Normal or BIT Fault).
- The detector's status changes (from Normal to BIT Fault or vice versa) if the BIT differs from the current status.



**Note:**

In "BIT Fault" status the detector can continue to detect a fire.

### 2.5.2.2 Automatic BIT

The detector automatically performs a BIT every 15 minutes. A successful BIT sequence does not activate any indicator.

All outputs of BIT results function as described in Table 10 and Table 11, and the BIT is automatically executed every 1 minute.

This sequence continues until a successful BIT occurs, when the detector resumes normal operation.

**Table 10: Results of a Successful BIT**

Output	Result
Fault Relay	<ul style="list-style-type: none"> <li>• Wiring options 1, 2, and 4: remains Closed</li> <li>• Wiring options 3 and 5: remains Open</li> </ul>
0–20mA Output	Wiring options 1, 2, and 3: Normal (4mA)
Power LED	Green, Flashing, 1Hz On (Normal)

**Table 11: Results of an Unsuccessful BIT**

Output	Result
Fault Relay	<ul style="list-style-type: none"> <li>Wiring options 1, 2, and 4: changes to Open</li> <li>Wiring options 3 and 5: changes to Closed</li> </ul>
0–20mA Output	Wiring options 1, 2, and 3: BIT Fault (2mA)
Power LED	Yellow, Flashing, 4Hz
BIT Procedure	Performed every 1 minute

### 2.5.2.3 Manual BIT

The BIT is manually initiated by momentarily connecting Terminal 3 with Terminal 2 (or a switch across these terminals in the safe area).

The results of a successful and unsuccessful Manual BIT are listed in Table 12 and Table 13.

**Table 12: Results of a Successful Manual BIT**

Output	Result
Fault Relay	<ul style="list-style-type: none"> <li>Wiring options 1, 2, and 4: remains Closed (Normal)</li> <li>Wiring options 3 and 5: remains Open (Normal)</li> </ul>
Alarm Relay	Activated for 3 sec (only when the function <b>alarm BIT</b> is set to YES)
Auxiliary Relay	For wiring options 4 and 5: is activated for 3 sec (only when the function <b>auxiliary BIT</b> is set to <b>Yes</b> )
0–20mA Output	Wiring options 1, 2, and 3: <ul style="list-style-type: none"> <li>Initiates 20mA only when the function alarm BIT is set to Yes</li> <li>Initiates 16mA when the function auxiliary BIT is set to Yes and the function alarm <b>BIT</b> is set to <b>No</b></li> </ul>
Power LED	Green, Flashing, 1Hz

**Table 13: Results of an Unsuccessful Manual BIT**

Output	Result
Fault Relay	<ul style="list-style-type: none"> <li>Wiring options 1, 2, and 4: changes to Open</li> <li>Wiring options 3 and 5: changes to Closed</li> </ul>
0–20mA Output	Wiring options 1, 2, and 3: Indicates BIT Fault (2mA)
Power LED	Yellow, Flashing, 4Hz



#### **2.5.2.4 Manual BIT Only**

The BIT is initiated manually by momentarily connecting Terminal Number 3 with Terminal Number 2 (or a switch across these terminals in the safe area).



## 3 Installing the Detector

This chapter provides basic guidelines for installing the detector. It does not attempt to cover all of the standard practices and codes of installation. Rather, it emphasizes specific points of consideration and provides some general rules for qualified personnel. Wherever applicable, special safety precautions are stressed.

### 3.1 General Guidelines

To ensure optimal performance and an efficient installation, consider the following guidelines:

#### 3.1.1 Sensitivity

To determine the level of sensitivity, consider the following:

- Size of fire at the required distance to be detected
- Type of flammable materials

#### 3.1.2 Wiring

- The wire gauge must be designed according to the distance from the detector to the controller and the number of detectors on the same power line. See *Wiring Instructions* on page 63.
- To fully comply with EMC directive and protect against interference caused by RFI and EMI, the cable to the detector must be shielded and the detector must be grounded. The shield should be grounded at the detector end.

#### 3.1.3 Spacing and Location

The number of detectors and their locations in the protected area are determined by:

- Size of the protected area
- Sensitivity of the detectors
- Obstructed lines of sight
- Cone of view of the detectors

#### 3.1.4 Environment

- Dust, snow, or rain can reduce the detector's sensitivity and require more maintenance activities.
- The presence of high intensity flickering IR sources may affect sensitivity.

#### 3.1.5 Aiming the Detector

- The detector should be aimed toward the center of the detection zone and have a completely unobstructed view of the protected area.

- Whenever possible, the detector face should be tilted down at a 45° angle to maximize coverage and prevent accumulation of dust and dirt.
- Do not start an installation unless all conceivable considerations regarding detection location have been taken into account.

Installation should comply with **NFPA 72E or any other local and international regulations and standards**, as applicable to flame detectors and installation of Ex approved products.

## 3.2 Unpacking the Product

Upon receipt of your detector, verify that you have received the following contents:

- Delivery form
- Flame detector
- Plastic weather cover
- User manual
- Quality document
- Tool keys (per shipment)

Check and record the following:

- Verify the appropriate Purchase Order.
- Record the Part Number (P/N) and Serial Number of the detectors and the installation date in an appropriate logbook.
- Verify that all components required for the detector installation are readily available before beginning the installation. If the installation is not completed in a single session, secure and seal the detectors and conduits/cable entries.

### 3.2.1 Checking the Product Type

Check that your product has the configuration/options that you ordered. Check the detailed part number on the label and compare this information with the descriptions contained in *Model and Types* on page 16.

### 3.3 Required Tools

The detector can be installed using general-purpose common tools and equipment. Table 14 lists the specific tools required to install the detector.

**Table 14: Tools**

Tool	Function	Comments
Hex key $\frac{3}{16}$ "	Open and close detector cover (for wiring)	Part of the kit
Hex key $\frac{1}{4}$ "	Mount the detector on the tilt mount	Part of the kit
Flat screwdriver 6mm	Connect ground terminal	Standard tool
Flat screwdriver 2.5mm	Connect wires to the terminal blocks	Standard tool

For wiring, use color-coded conductors or suitable wire markings or labels. 12–20AWG / 0.5–3.5mm<sup>2</sup> wires may be used for site wiring. The selection of wire gauge should be based on the number of detectors used on the same line and the distance from the control unit, in compliance with specifications (see *General Instructions for Electrical Wiring* on page 63).

### 3.4 Certification Instructions



**Warning:**

Do not open the detector, even when isolated, in the presence of any open flame.

#### 3.4.1 Special Instructions for Safe Use

The dimensions of the flamepaths are other than the relevant minimum or maximum, as required by Table 2 of EN 60079-1:2014, as detailed below:

Flamepath Location	Type of Joint	Maximum Gap, $i_c$	Minimum Length, L
Sapphire Window	Flanged	0.04mm	10.5mm
Main Spigot	Cylindrical	0.15mm	15.5mm

Gaps,  $i_c$ , should not be modified to be any larger, and lengths, L, should not be modified to be any shorter than the values shown in the table above.

- Units may be painted or fitted with optional accessories, some of which are made of a non-metallic material or have a non-metallic coating which could potentially generate an ignition-capable level of electrostatic charge under certain extreme conditions. Therefore, these units should not be installed in a location where they may be subjected to external conditions (such as high-pressure steam) which might cause a build-up of electrostatic charges on the non-conducting surfaces. Cleaning of the equipment (except window) should be done only with a damp cloth.
- The 3 fastening screws used to screw on the cover of the flameproof compartment have a yield stress of 344N/mm<sup>2</sup>. Any replacement fasteners must have a yield stress of at least this value.
- When the duct mount is fitted and the equipment is intended to be mounted to a heated/cooled air duct/process vessel, it should be verified that the temperature of the air duct/process vessel should not be capable of heating or cooling any part of the equipment enclosure to a temperature outside the marked maximum ambient temperature range prior to switching the equipment on, when taking into account surrounding ambient temperature.

### 3.4.2 General Instructions

- The cable entry point may exceed 167°F/75°C. Suitable precautions should be taken when selecting the cable.
- The equipment may be used with flammable gases and vapors with apparatus groups IIA, IIB and IIC:
  - T4 in the ambient temperature range: -67°F/-55°C to +167°F/+75°C.
  - T4 in the ambient temperature range: -67°F/-55°C to +185°F/+85°C.
- Installation should be carried out by suitably trained personnel in accordance with the applicable code of practice such as EN 60079-14:1997.
- Inspection and maintenance of this equipment should be carried out by suitably trained personnel in accordance with the applicable code of practice such as EN 60079-17.
- Repair of this equipment should be carried out by suitably trained personnel in accordance with the applicable code of practice such as EN 60079-19.
- The certification of this equipment relies upon the following materials used in its construction:
  - **Enclosure:** 316L Stainless steel or aluminum
  - **Window:** Sapphire glass
- If the equipment is likely to come into contact with aggressive substances, then it is the responsibility of the user to take suitable precautions that prevent it from being adversely affected, thus ensuring that the type of protection provided by the equipment is not compromised:
  - Aggressive substances: acidic liquids or gases that may attack metals, or solvents that may affect polymeric materials.
  - Suitable precautions: regular checks as part of routine inspections or establishing from the material's data sheets that it is resistant to specific chemicals.

## 3.5 Installation Cables

Follow this guideline for the cable installation:

- All cables to the detector must be well shielded in order to comply with EMC requirements (see *Electromagnetic Compatibility (EMC)* on page 61).
- Ground the detector to the nearest ground point (not more than 3m from the detector location).
- Install the detector with the cable entries placed downwards.

### 3.5.1 Conduit Installation

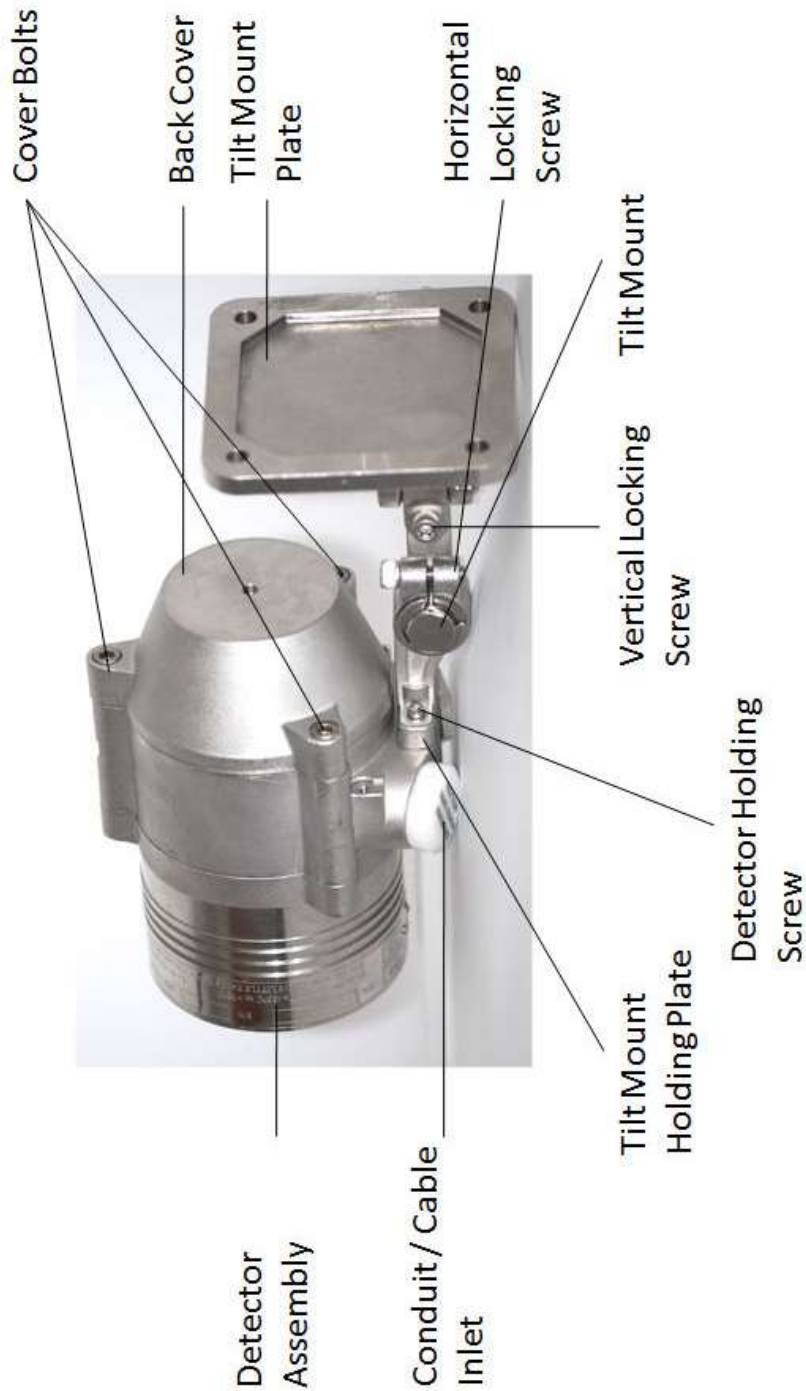
The conduit used for the cabling must comply with the following:

- To avoid water condensation or water in the detector, install the detector with the conduits placed downward to include drain holes.
- When using the optional tilt mount, use flexible conduits for the last portion connecting to the detector.
- For installations in atmospheres as defined in group B of the NFPA 72E, seal the conduits' inlets.
- When pulling the cables through the conduits, ensure that they are not tangled or stressed. Extend the cables about 30cm/12" beyond the detector location to accommodate wiring after installation.
- After the conductor cables have been pulled through the conduits, perform a continuity test.

### 3.6 Installing the Tilt Mount

The tilt mount (P/N 40/40-001) enables the detector to be rotated up to 60° in all directions.

Figure 5 shows the detector mounted on the tilt mount.

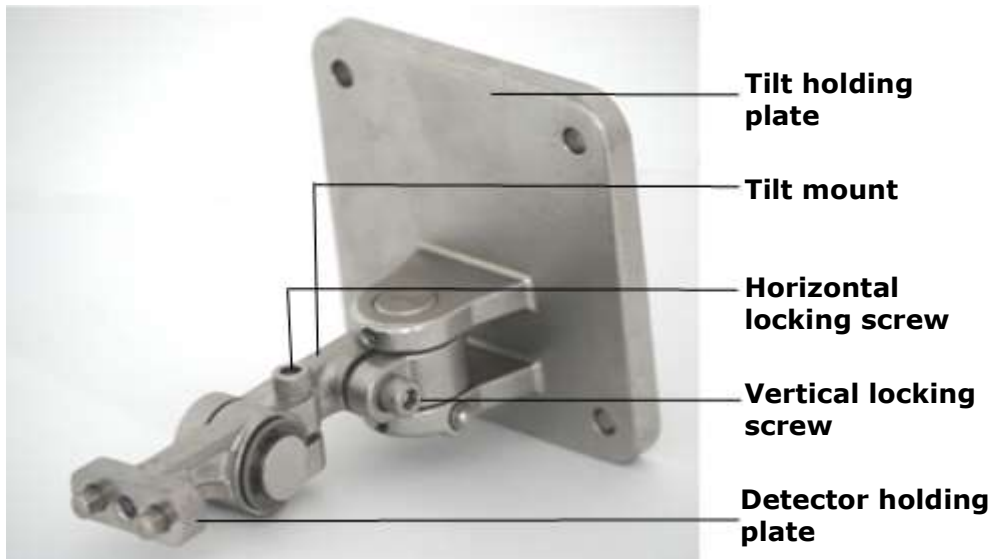


**Figure 5: Detector with Tilt Mount**



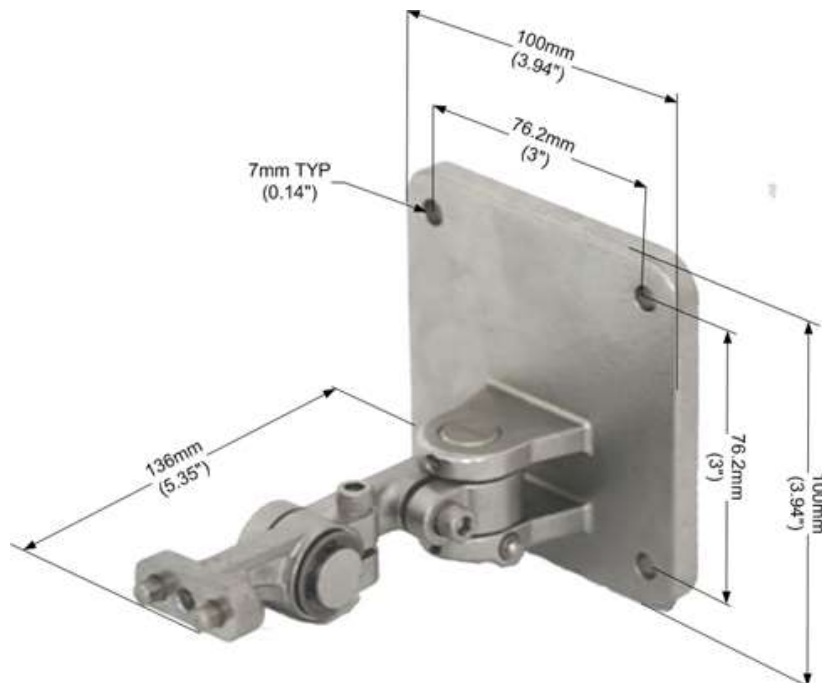
### 3.6.1 Tilt Mount Assembly

Figure 6 shows the tilt mount assembly with dimensions in both millimeters and inches.



**Figure 6: Tilt Mount Assembly**

Figure 7 shows the tilt mount assembly with dimension in both millimeters and inches.



**Figure 7: Tilt Mount Assembly (dimensions in millimeters and inches)**

- **To install the tilt mount and detector:**

- 1 Place the tilt mount in its designated location and secure it with 4 fasteners through 4 holes 7mm in diameter. Use the 4 screws and spring washers according to the kit.

**Note:**

Removing the detector for maintenance purpose does not require the tilt mount to be removed.

---

- 2 Unpack the detector.
- 3 Place the detector with its conduit/cable entries pointing downwards on the holding plate of the tilt mount. Secure the detector with  $\frac{5}{16}$ " 18 UNC x 1" screw to the tilt mount.
- 4 Release the horizontal and vertical locking screws using  $\frac{3}{16}$ " Hex Key so that the detector can be rotated. Point the detector towards the protected area and make certain that the view of the area is unobstructed. Secure the detector in that position by tightening the locking screws on the tilt mount, making sure the detector is in the correct position.

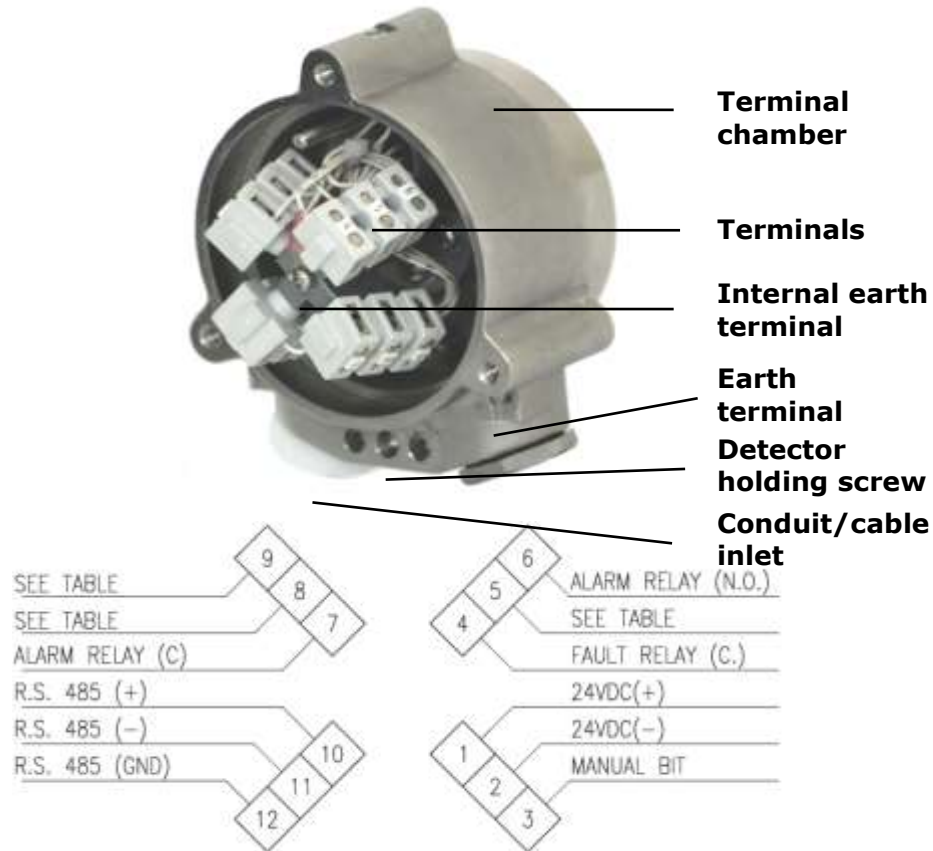
The detector is now correctly located, aligned, and ready to be connected to the system.

## 3.7 Connecting the Detector

This section describes how to connect the electric cabling to the detector (Figure 8).

- **To connect the detector to the electrical cables**

- 1 Disconnect the power.
- 2 Remove the back cover of the detector by removing 3 socket head-screws in the cover bolts. The terminal chamber is now revealed.
- 3 Remove the protective plug mounted on the detector conduit/cable entry; pull the wires through the detector inlet.
- 4 Use a  $\frac{3}{4}$ " – 14 NPT explosion-proof conduit connection or M25x1.5 flameproof gland to assemble the cable/conduit to the detector.



**Figure 8: Detector with Cover Removed**

- 5** Connect the wires to the required terminals on the Terminal Board according to the wiring diagram (Figure 8) and Table 15.
- 6** Connect the grounding (earth) wire to the ground (earth) screw outside the detector (earth terminal). The detector must be well grounded to earth ground.
- 7** Verify the wiring.



**Warning:**

Improper wiring may damage the detector.

- 8** Check the wires for secure mechanical connection and press them neatly against the terminal to prevent them from interfering while closing the back cover (Figure 8).
- 9** Place and secure the detector's back cover by screwing the 3 socket-head-screws in the cover bolts (Figure 5).

### 3.7.1 Verifying the Detector Wiring

The detector has 5 output wiring options within the Exde integral terminal section of the enclosure. There are 12 terminals labeled 1–12.

Table 15 describes the function of each terminal for all the wiring options.

**Table 15: Model 40/40M Wiring Options**

Wire Terminal No.	Option 1 Default	Option 2	Option 3	Option 4
1	+24VDC	+24VDC	+24VDC	+24VDC
2	0VDC	0VDC	0VDC	0VDC
3	Manual BIT	Manual BIT	Manual BIT	Manual BIT
4	Fault Relay N.C.	Fault Relay N.C.	Fault Relay N.O.	Fault Relay N.C.
5				
6	Alarm Relay N.O.	Alarm Relay N.O.	Alarm Relay N.O.	Alarm Relay N.O.
7	Alarm Relay C	Alarm Relay C	Alarm Relay C	Alarm Relay C
8	0–20mA In	Alarm Relay N.C.	Alarm Relay N.C.	Auxiliary N.O.
9	0–20mA Out*	0–20mA Out*	0–20mA Out*	Auxiliary C
10	RS-485+(1)	RS-485+(1)	RS-485+(1)	RS-485+(1)
11	RS-485-(1)	RS-485-(1)	RS-485-(1)	RS-485-(1)
12	RS-485 GND	RS-485 GND	RS-485 GND	RS-485 GND

\* Available with the HART protocol.

- RS-485 is used for the communication network as specified in *RS-485 Communication Network* on page 69 (Terminals 10, 11, and 12) and to connect (in a safe area) to a PC or laptop for configuration and diagnostics.
- Alarm relay:
  - N.O. contact in wiring options 1, 4, and 5.
  - N.O. and N.C. in wiring options 2 and 3.
- 0–20mA is “Sink” in option 1 and “Source” in options 2 and 3.
- 0–20mA options 1, 2, and 3 are available with the HART protocol.
- In wiring option 1, link Terminals 1 and 8 to change the mA output to “Source.”
- The fault output is N.C. energized SPST relay. The contacts are closed when the detector is in its normal operational condition in options 1, 2, and 4, and available as N.O. energized in options 3 and 5.
- The auxiliary output is N.O. (SPST) relay. Depending on the function configuration, the auxiliary relay may act in parallel with the alarm relay to activate another external device, or it may provide a warning signal.

## 3.8 Configuring Your Detector

You can reprogram the function setup using the RS-485 connection or the HART protocol as follows:

- **USB RS-485 Harness Kit** (P/N 794079): The USB RS-485 Harness Kit with RS-485/USB converter, used with the SPECTREX host software, enables you to connect to any available PC or laptop to re-configure settings or perform diagnostics on all 40/40 series flame detectors.

Refer to *Manual TM777050* for programming instructions when using the USB RS-485 Harness Kit.

- **HART Protocol:** Refer to *Manual TM777030* for programming instructions.

These functions enable you to set:

- Sensitivity
- Alarm Delay
- Address Setup
- Mode of Operation
- Heated Optics Operation

The factory default settings listed for each function are:

- Sensitivity – 30
- Alarm Delay – A
- Alarm Latch – No
- Auxiliary Relay – No
- Automatic BIT – Yes
- Alarm BIT – No
- Auxiliary BIT – No
- EOL – No
- Heated Optics – Auto
- Temperature – 41°F/5°C

### 3.8.1 Sensitivity

The detector offers 4 sensitivity settings. The settings refer to an n-heptane or gasoline fire of 1ft<sup>2</sup>/0.1m<sup>2</sup>, from low sensitivity of 50ft/15m to 215ft/65m. For other types of fuel sensitivity, refer to Table 3.

**Table 16: Sensitivity Settings**

Sensitivity Setting	Detector Distance (ft)	Detector Distance (m)
15	50	15
30 (default)	100	30
45	150	45

Sensitivity Setting	Detector Distance (ft)	Detector Distance (m)
60	215	65

### 3.8.2 Alarm Delay

The detector is equipped with an alarm delay option, which provides programmable time delays with settings at:

- Antiflare (default)



**Note:**

The Antiflare mode is selected to prevent false alarms in locations where fast flares may be present. The time delay for fire alarms in this mode ranges from 2.5 to 15 seconds, and is usually less than 10 seconds.

Other delay settings are available:

- 0, 3, 5, 10, 15, 20, or 30 seconds

When an alarm (detection) level condition occurs, the detector delays the execution of the alarm outputs by the specified period of time. The detector then evaluates the condition for 3 seconds. If the alarm level is still present, the alarm outputs are activated. If this condition no longer exists, the detector returns to its standby state.

The alarm delay option affects the output relays and the 0–20mA. The LEDs and outputs indicate warning levels during the delay time only if the fire condition exists.

### 3.8.3 Address Setup

The detector provides up to 247 addresses that can be changed with the RS-485 communication link or the HART protocol.

### 3.8.4 Function Setup

You can select the desired functions as detailed in Table 17.

**Table 17: Functions**

Function	Setting
Alarm Latch	<ul style="list-style-type: none"> <li>• Yes: Enable alarm latching.</li> <li>• No: Disable alarm latching (default).</li> </ul>
Auxiliary Relay*	<ul style="list-style-type: none"> <li>• Yes: Activate auxiliary relay at warning level.</li> <li>• No: Activate auxiliary relay at alarm level (default).</li> </ul>
Automatic BIT	<ul style="list-style-type: none"> <li>• Yes: Perform automatic and manual BIT (default).</li> <li>• No: Perform manual BIT only.</li> </ul>

Function	Setting
Alarm BIT	<ul style="list-style-type: none"> <li>• Yes: Successful manual BIT activates the alarm relay for approximately 3 seconds (default).</li> <li>• No: Successful manual BIT does not activate the alarm relay.</li> </ul>
Auxiliary BIT*	<ul style="list-style-type: none"> <li>• Yes: Successful manual BIT activates the auxiliary relay for approximately 3 seconds (default).</li> <li>• No: Successful manual BIT does not activate the auxiliary relay.</li> </ul>
EOL*	<ul style="list-style-type: none"> <li>• Yes: Auxiliary relay is used as End of Line.</li> <li>• No: Auxiliary relay operates in accordance with Functions 2 and 5 (default).</li> </ul>

\* Only available in Models 40/40M-4XXXX and 5XXXX

### 3.8.5 Heated Optics

The heated optics can be defined as one of the following modes:

- Heated Mode
  - Off: Not operated
  - On: Continuously
  - Auto: Per temperature change

In Auto mode, the default Heat On setting is 41°F/5°C. Heating stops when the temperature is 27°F/15°C above the start temperature.

You can define the start temperature below which the window will be heated. The temperature can be defined between 32–86°F / 0–30°C.





## 4 Operating the Detector

This chapter describes how to power up and test the detector. It also includes some very important safety checks that you should complete before operating the detector.

### 4.1 Powering Up

This section describes how to power up the detector. Follow these instructions carefully to obtain optimal performance from the detector over its life cycle:

- **To power up the detector:**

- 1 Turn on the power.
- 2 Wait up to 60 seconds for the detector to finish the start-up procedure.

Applying power initiates the following sequence of events:

- The yellow LED flashes at 4Hz.
- BIT is executed.

If successful, the green LED flashes at 1Hz, the fault relay contacts close, and mA output is 4mA.

- 3 Enter Normal mode.



**Note:**

The majority of detectors are used in the default non-latched alarm mode. Only perform a Reset when the latched alarm option has been programmed.

---

- **To reset the detector when it is in a Latched Alarm state:**

- Disconnect power (Terminal 1 or Terminal 2)  
Or
- Initiate a Manual BIT

### 4.2 Safety Precautions

After powering up, the detector requires almost no attention in order to function properly, but the following should be noted:

- Follow the instructions in this guide and refer to the drawings and specifications.
- Do not expose the detector to radiation of any kind unless required for testing purposes.
- Do not open the detector housing while power is connected.

- Do not open the electronic compartment. This part should be kept closed at all times and only opened in the factory. Opening the electronic component side invalidates the warranty.
- You should only access the wiring compartment to wire or remove the detector, or to access RS-485 terminals for maintenance.
- External devices such as automatic extinguishing systems must be disconnected or disabled before carrying out any maintenance.

## 4.2.1 Default Functions Settings

Table 18 lists the default function configuration supplied with the detector.

**Table 18: Default Function Values**

Function	Value	Notes
Sensitivity	30	
Alarm Delay	A	
Alarm Latch	No	
Auxiliary Relay	No	In wiring options 1, 2, and 3 the auxiliary relay is not available. This function is not used.
Automatic BIT	Yes	
Alarm BIT	No	
Auxiliary BIT	No	In wiring options 1, 2, and 3 the auxiliary relay is not available. This function is not used.
EOL	No	In wiring options 1, 2, and 3 the auxiliary relay is not available. This function is not used.
Heat Mode	Auto	
Heat On	41°F/5°C	The detector starts heating the window for any temperature below this value (in degrees Celsius).

- **To change the default function, use:**
  - USB RS-485 Harness Kit P/N 794079. Refer to *Manual TM777050* for programming instructions when using the USB RS-485 Harness Kit.
  - HART protocol, refer to *Manual TM777030* for instructions.

## 4.3 Testing Procedures

This section describes the proof testing procedure for proper operation of the detector. The detector can be tested using the Manual BIT or the SPECTREX Flame Simulator FS-1400.

The detector performs internal tests continuously and automatic BIT tests every 15 minutes. For more details refer to *Built-In-Test (BIT)* on page 31.

### 4.3.1 Automatic BIT Test

Check that the indicators show normal conditions. See *Powering Up* on page 49.

### 4.3.2 Manual BIT Test



**Caution:**

If the function setup **Alarm BIT** and/or **Auxiliary BIT** are set to **Yes** (default is **No**), the alarm, auxiliary relay, and 0–20mA outputs are activated during a Manual BIT. Therefore, automatic extinguishing systems or any external devices that may be activated during BIT **must** be disconnected.

---

■ **To perform a Manual BIT:**

- 1 Verify that the detector is in Normal Mode.
- 2 Initiate Manual BIT.

The results of successful and unsuccessful manual BITs are detailed in Table 12 and Table 13.

### 4.3.3 Testing with Flame Simulator Model FS-1400

The Flame Simulator Model FS-1400 can be used to simulate exposure of the detector to a real fire condition. The detector is exposed to radiation at the required detection level. As a result, the detector will generate a Fire Alarm signal. See *Flame Simulator FS-1400* on page 71 for more information.



**Caution:**

If the detector is exposed to a flame simulator, the alarm and accessory relays and 0–20mA are activated during the simulation. Therefore, automatic extinguishing systems and any external devices which may be activated during this process must be disconnected.

---

■ **To perform a flame simulator test:**

- 1** Power up the system and wait up to 60 seconds for the detector to turn to a normal state. The Power LED turns on.
- 2** Aim the SPECTREX Flame Simulator Model FS-1400 at the target point of the detector such that the radiation emitted by it is facing directly towards the detector. (See *Flame Simulator FS-1400* on page 71.
- 3** Press the operation button once. After few seconds, a successful test shows the results listed in Table 19.

The detector is now ready for operation.

**Table 19: Results of Successful Flame Simulator Test**

Component	Action	Notes
0-20mA	Turn to 20mA	For a few seconds and then returns to 4mA
Alarm Relay	Activated	For a few seconds and then returns to Normal
Auxiliary Relay	Activated	For a few seconds and then returns to Normal
Fault Relay	Remains active during the test	
LED	Red, steady	

## 5 Maintenance and Troubleshooting

This chapter deals with preventive maintenance, describes possible faults in detector operation and indicates corrective measures. Ignoring these instructions may cause problems with the detector and may invalidate the warranty. Whenever a unit requires service, please contact SPECTREX or its authorized distributor for assistance.

### 5.1 Maintenance

This section describes the basic maintenance steps that should be taken to keep the detector in good working condition.

#### 5.1.1 General Procedures

Maintenance should be performed by suitably qualified personnel who are familiar with local codes and practice. Maintenance requires ordinary tools.

##### 5.1.1.1 Cleaning

The detector must be kept as clean as possible. Clean the viewing window and the reflector of the flame detector periodically.

The frequency of cleaning operations depends upon the local environmental conditions and specific applications. The fire detection system designer will give his recommendations.

- **To clean the detector viewing window and reflector:**
  - 1 Disconnect power to the detector before proceeding with any maintenance including window/lens cleaning.
  - 2 Use water and detergent, and then rinse the viewing window with clean water.
  - 3 Where dust, dirt, or moisture accumulates on the window, first clean with a soft optical cloth and detergent only, and then rinse with clean water.

#### 5.1.2 Periodic Procedures

In addition to preventive cleaning and maintenance, the detector should be functionally tested every 6 months or as dictated by local codes and regulations. These tests should also be conducted if the detector has been opened for any reason.

##### 5.1.2.1 Power-Up Procedure

Perform the power-up procedure every time power is restored to the system. Follow the instructions described in *Powering Up* on page 49.

### 5.1.2.2 Functional Test Procedure

Perform a functional test of the detector as described in *Internal Detector Tests* on page 30.

### 5.1.3 Keeping Maintenance Records

Maintenance operations performed on a detector should be recorded in a logbook. The record should include the following:

- Installation date
- Contractor
- Serial and tag number
- Entries for every maintenance operation performed, including a description of the operation, date, and personnel ID

If a unit is sent to SPECTREX or a distributor for service, a copy of the maintenance records should accompany it.

## 5.2 Troubleshooting

This section is a guide to correct problems which may happen during normal operation.

**Table 20: Troubleshooting Table**

Problem	Cause	Corrective Action
LEDs Off Fault Relay at N.O. 0–20mA at 0mA	No power to the unit	<ul style="list-style-type: none"> <li>• Check that the correct power is sent to the detector.</li> <li>• Check power polarity.</li> <li>• Check wiring in the detector.</li> <li>• Send the detector back for repairs.</li> </ul>
Yellow/amber LED flashes at 4Hz Fault Relay at N.O. 0–20mA at 0mA	Fault Detector <ul style="list-style-type: none"> <li>• Low Voltage</li> <li>• Faulty Detector</li> </ul>	<ul style="list-style-type: none"> <li>• Check the voltage at the detector; verify at least 24V at the detector terminal.</li> <li>• Send the detector back for repairs.</li> </ul>
Yellow/amber LED flashes at 4Hz Fault Relay at N.O. 0–20mA at 2mA	BIT Fault <ul style="list-style-type: none"> <li>• Faulty Detector</li> </ul>	<ul style="list-style-type: none"> <li>• Clean detector window.</li> <li>• Re-power the detector.</li> <li>• Replace the detector.</li> </ul>
Red LED constantly on	If no fire exists, then, detector alarm latched	<ul style="list-style-type: none"> <li>• Perform a <b>Reset</b>.</li> </ul>
Alarm Relay at On 0–20mA at 20mA	Alarm condition	<ul style="list-style-type: none"> <li>• Check cause of alarm.</li> <li>• If no alarm, re-power the detector.</li> <li>• Send the detector back for repairs.</li> </ul>

## Appendix A: Specifications

### A.1 Technical Specifications

<b>Spectral Response</b>	<b>Multi IR Bands</b>			
<b>Detection Range (at highest sensitivity setting for 1ft<sup>2</sup>/0.1m<sup>2</sup> pan fire)</b>	<b>Fuel</b>	<b>ft/m</b>	<b>Fuel</b>	<b>ft/m</b>
	n-Heptane	215/65	Kerosene	150/45
	Gasoline	215/65	Ethanol 95%	135/40
	Diesel Fuel	150/45	Methanol	115/35
	JP5	150/45	IPA (Isopropyl Alcohol)	135/40
	Methane <sup>1</sup>	150/45	Polypropylene Pellets	115/35
	LPG <sup>1</sup>	150/45	Ammonia <sup>2</sup>	60/18
	Hydrogen <sup>1</sup>	125/38	Silane <sup>2</sup>	7/2
	Office Paper	82/25		
			<sup>1</sup> 30"/0.75m high, 10"/0.25m width plume fire	
			<sup>2</sup> 20"/0.5m high, 8"/0.2m width plume fire	
<b>Response Time</b>	Typically 5 seconds			
<b>Adjustable Time Delay</b>	Up to 30 seconds			
<b>Sensitivity Ranges</b>	2 ranges for 1ft <sup>2</sup> /0.1m <sup>2</sup> n-heptane pan fire from 50ft/15m to 215ft/65m			
<b>Fields of View</b>	Gasoline: Horizontal 80°, Vertical 80° Hydrogen: Horizontal 70°, Vertical 80°			
<b>Built-In-Test (BIT)</b>	Automatic (and Manual)			

## A.2 Electrical Specifications

**Operating Voltage:** 18–32VDC

**Power Consumption:** Table 21

**Table 21: Electrical Specifications**

Operating Voltage	Status	All Outputs	Without 0–20mA
Power Consumption (Max. 24VDC)	Normal	1.61W	1.56W
	Normal when Heater On	2.28W	2.16W
	Alarm	2.64W	2.28W
	Alarm when Heater On	3.24W	2.88W
Maximum Current (Max. 24VDC)	Normal	70mA	65mA
	Normal when Heater On	95mA	90mA
	Alarm	110mA	95mA
	Alarm when Heater On	135mA	120mA
Power Consumption (Max. 18–32VDC)	Normal	1.95W	1.85W
	Normal when Heater On	2.56W	2.45W
	Alarm	3.04W	2.56W
	Alarm when Heater On	3.68W	3.2W
Maximum Current (Max. 18–32VDC)	Normal	90mA	85mA
	Normal when Heater On	105mA	100mA
	Alarm	130mA	115mA
	Alarm when Heater On	160mA	145mA

### A.2.1 Electrical Input Protection

The input circuit is protected against voltage-reversed polarity, voltage transients, surges, and spikes according to MIL-STD-1275B

## A.3 Outputs

### A.3.1 Electrical Interface

There are 5 output wiring options. These options are defined at the factory per the customer order and cannot be changed at the customer facility.

See *General Instructions for Electrical Wiring* on page 63 for the wiring/terminal diagram for each option.



Unless otherwise specified, the default is option 1. The wiring arrangement is identified on the detector by the part number (see *Model and Types* on page 16).

- **Option 1:** Power, RS-485, 0–20mA (Sink), fault I relay (N.C.), alarm relay, (N.O.) (see Figure 8).
- **Option 2:** Power, RS-485, 0–20mA (Source) and HART protocol, fault relay (N.O.), alarm relay, (N.O.), and (N.C.).
- **Option 3:** Power, RS-485, 0–20mA (Source) and HART protocol, fault relay (N.O.), alarm relay (N.O., N.C.).
- **Option 4:** Power, RS-485, fault relay (N.C.), auxiliary relay (N.O.), alarm relay, (N.O.).
- **Option 5:** Power, RS-485, fault relay (N.O.), auxiliary relay (N.O.), alarm relay, (N.O.).

## A.3.2 Electrical Outputs

### A.3.2.1 Dry Contact Relays

**Table 22: Contact Ratings**

Relay Name	Type	Normal Position	Maximum Rating
Alarm	SPDT	N.O., N.C.	2A at 30DVC
Auxiliary	SPST	N.O.	2A at 30VDC
Fault <sup>1,2</sup>	SPST	N.C. or N.O.	2A at 30VDC

<sup>1</sup> The fault relay (in wiring options 1, 2, and 4) is normally energized closed during normal operation of the detector. The relay is de-energized open in a fault condition or low voltage situation.

<sup>2</sup> In wiring options 3 and 5 the relay is normally energized open during normal operation of the detector. The relay is de-energized close contact in a fault condition or low voltage situation.

### A.3.2.2 0–20mA Current Output

The 0–20mA can be Sink or Source according to the wiring option source (see *General Instructions for Electrical Wiring* on page 63). The maximum permitted load resistance is 600Ω.

**Table 23: 20mA Current Output**

State	Output
Fault	0 +1mA
BIT fault	2mA±10%
Normal	4mA±10%
Warning	16mA±5%
Alarm	20mA±5%

### A.3.2.3 HART Protocol

The HART protocol is a digital communication signal at a low level on top of the 0–20mA. This bi-directional field communication protocol is used to communicate between intelligent field instruments and the host system. HART is available in wiring options 2 and 3.

Through the HART protocol the detector can:

- Display setup
- Reconfigure setup
- Display detector status and definition
- Perform detector diagnostics
- Troubleshoot

For more details refer to *HART Manual TM777030*.

### A.3.2.4 Communication Network:

The detector is equipped with an RS-485 communication link that can be used in installations with computerized controllers.

The communications protocol is Modbus compatible.

- This protocol is a standard and widely used.
- It enables continuous communication between a standard Modbus controller (Master device) and a serial Network of up to 247 detectors.

### A.3.3 Heated Optics

The front window can be heated to improve performance in ice, condensation, and snow conditions. The heater increases the temperature of the optical surface by 5–8°F / 3–5°C above the ambient temperature. The heated optics can be configured in 3 ways:

- **Off:** The optics are not heated
- **On:** The optics are heated continuously
- **Auto:** Operated only when the change of temperature requires the heating (default)

In Auto mode the start heating temperature can be defined between 32–86°F / 0–30°C. The detector stops heating the window when the temperature is 27°F/15°C above the start temperature.

## A.4 Approvals

### A.4.1 Hazardous Area Approvals

- FM, CSA  
Class I Div. 1 Groups B, C, and D;  
Class II/III Div. 1 Groups E, F, and G
- ATEX, IECEx  
Ex II 2G D  
Ex db eb op is IIC T4 Gb  
Ex tb op is IIIC T96°C Db  
(-55°C ≤ Ta ≤ +75°C)  
Or  
Ex II 2G D  
Ex db eb op is IIC T4 Gb  
Ex tb op is IIIC T106°C Db  
(-55°C ≤ Ta ≤ +85°C)
- TR CU / EAC  
1 Ex db eb op is IIC T4 Gb X  
Ex tb op is IIIC T96°C Db X  
(-55°C ≤ Ta ≤ +75°C)  
Or  
1 Ex db eb op is IIC T4 Gb X  
Ex tb op is IIIC T106°C Db X  
(-55°C ≤ Ta ≤ +85°C)  
Or  
1 Ex db eb mb op is II T4 Gb X  
Ex tb op is IIIC T98°C Db X  
(-55°C ≤ Ta ≤ +75°C)

### A.4.2 Functional Approvals

- EN54-10 approved per VdS
- FM approved per FM3260

## A.5 Mechanical Specifications

### **A.5.1 Enclosure**

- Stainless Steel 316  
Or
- Aluminum, heavy duty copper free (less than 1%), red epoxy enamel finish

### **A.5.2 Water and Dust Tight**

- NEMA 250 type 6p.
- IP 66 and IP 67 per EN 60529

### **A.5.3 Electronic Modules**

- Conformal coated

### **A.5.4 Electrical Connection (2 entries)**

- ¾" - 14NPT conduit  
Or
- M25 x 1.5

### **A.5.5 Dimensions**

4" x 4.6" x 6.18" / 101.6 x 117 x 157 mm

### **A.5.6 Weight**

- Stainless Steel: 6.1lb/2.8kg
- Aluminum: 2.8lb/1.3kg

## **A.6 Environmental Specifications**

The SharpEye 40/40M is designed to withstand harsh environmental conditions.

### **A.6.1 High Temperature**

- Designed to meet MIL-STD-810C, Method 501.1 Procedure II
- Operating temperature: +167°F/+75 °C
- Storage temperature: +185 °F/+85 °C

### **A.6.2 Low Temperature**

- Designed to meet MIL-STD-810C, Method 502.1, Procedure I
- Operating temperature: -57°F/-50°C
- Storage temperature: -65°F/-55°C

### **A.6.3 Humidity**

- Designed to meet MIL-STD-810C, Method 507.1, Procedure IV

- Relative humidity of up to 95% for the operational temperature range

#### A.6.4 Salt Fog

- Designed to meet MIL-STD-810C, Method 509.1, Procedure I
- Exposure to a 5% salt solution fog for 48 hours

#### A.6.5 Dust

- Designed to meet MIL-STD-810C, Method 510.1, Procedure I
- Exposure to a dust concentration of 0.3g/ft<sup>2</sup> at a velocity of 1750fpm, for 12 hours

#### A.6.6 Vibration

- Designed to meet MIL-STD-810C, Method 514.2, Procedure VIII
- Vibration at an acceleration of 1.1g within the frequency range of 5–30Hz, and an acceleration of 3g within the frequency range of 30–500Hz

#### A.6.7 Mechanical Shock

- Designed to meet MIL-STD-810C, Method 516.2, Procedure I
- Mechanical Shock of 30g half-sine wave, for 11 msec

#### A.6.8 Electromagnetic Compatibility (EMC)

**Table 24: Electromagnetic Compatibility (EMC)**

	Test Standard	Level Per
Electrostatic Discharge ESD	IEC 61000-4-2	EN 50130-4
Radiated EM Field	IEC 61000-4-3	EN 50130-4
Electrical Fast Transients	IEC 61000-4-4	EN 50130-4
Surge	IEC 61000-4-5	EN 50130-4
Conducted Disturbances	IEC 61000-4-6	EN 50130-4
Power Frequency Magnetic Field	IEC 61000-4-8	EN 50130-4
Radiated Emission	IEC 61000-6-3	EN 55022
Conducted Emission	IEC 61000-6-3	EN 55022
Immunity to Main Supply Voltage Variations	IEC 61000-4-29	EN 50130-4



**Caution:**

To fully comply with EMC directive 2014/30/EU and protect against interference caused by RFI and EMI, the cable to the detector must be

---

shielded and the detector must be grounded. The shield should be grounded at the detector end.

---

## Appendix B: Wiring Instructions

### B.1 General Instructions for Electrical Wiring

Follow the instructions detailed in this section for determining the correct wire gauge to be used for the installation.

- 1 Use Table 25 to determine the required wire gauge/size for general wiring, such as relay wiring. Calculate the permitted voltage drop with respect to load current, wire gauge, and length of wires.

**Table 25: Maximum DC Resistance at 68°F/20°C for Copper Wire**

AWG No.	mm <sup>2</sup>	Ohm per 100ft	Ohm per 100m
20	0.51-0.61	1.07	3.50
18	0.81-0.96	0.67	2.20
16	1.22-1.43	0.43	1.40
14	1.94-2.28	0.27	0.88

- 2 Use Table 26 to select wire gauge for power supply wires. DO NOT connect any circuit or load to detectors' supply inputs.
  - Select **number of detectors** connected in 1 circuit.
  - Select wiring **length** per your installation requirements.
  - Refer to **power supply** range for voltage extreme applied.

**Table 26: Wiring Length (ft/m)**

Number of Detectors	Recommended Wire Diameter (AWG)					Power Supply Range (VDC)
	18	16	14	-	-	
24	18	16	14	-	-	22-32
20	18	16	14	-	-	22-32
16	20	18	16	14	-	22-32
12	20	18	16	14	-	20-32
8	20	18	16	14	-	20-32
4 and less	20	18	16	16	14	20-32
ft/m	164/50	328/100	492/150	656/200	820/240	
	Max. Length from Power Supply to Last Detector					

### B.2 Calculation Formula

Use the following formula to calculate minimum wire gauge per wire length between the power supply (controller) and the detector, considering the number of detectors on the same power line, where:

- L = Actual wire length between the detector and the power supply
- N = Number of detectors per loop
- R = Resistance of wire per 100m (see Table 26)
- V = Voltage drop on the wire

■ **Calculate the voltage drop on the wire as follows:**

$$V = \frac{2L \times R \times N \times 0.2A}{100}$$

100

- 20+V = Minimum required voltage of the power supply
- 0.2A is the maximum power consumption of the detector

For example, if N=1 (1 detector in loop)

- L = 1000m
- Wire size = 1.5mm<sup>2</sup> (see Table 26, the resistance per 100m for 1.5mm<sup>2</sup> is 1.4Ω)

■ **Calculate the voltage drop in the wire as follows:**

$$\frac{2 \times 1000 \times 1.4\Omega \times 1 \times 0.2A}{100} = 5.6V$$

100

The minimum voltage of the power supply should be 20V + 5.6V = 25.6V

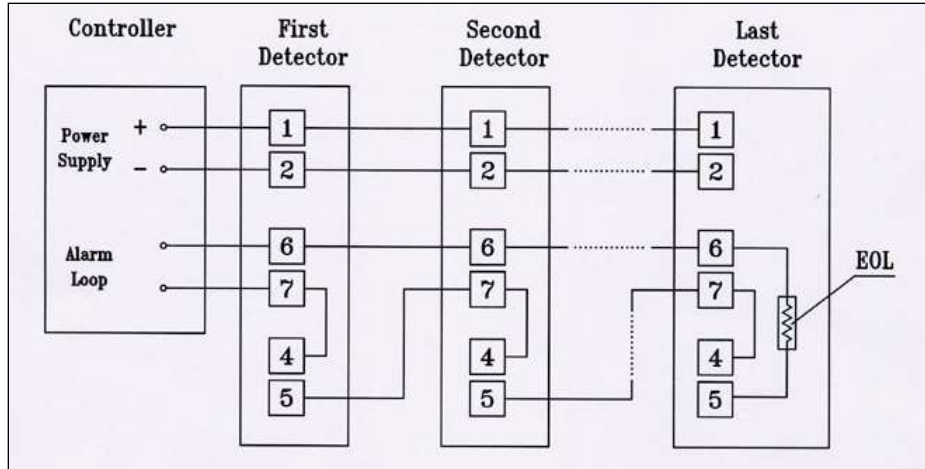
## B.3 Typical Wiring Configurations

This section describes examples of typical wiring configurations.

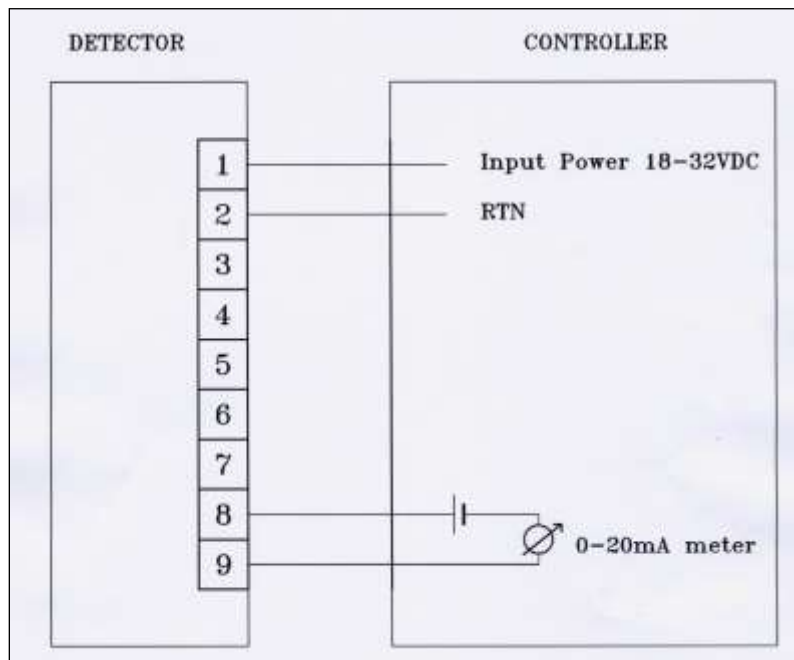



**Figure 9: Wiring Terminals**
**Table 27: Wiring Connections**

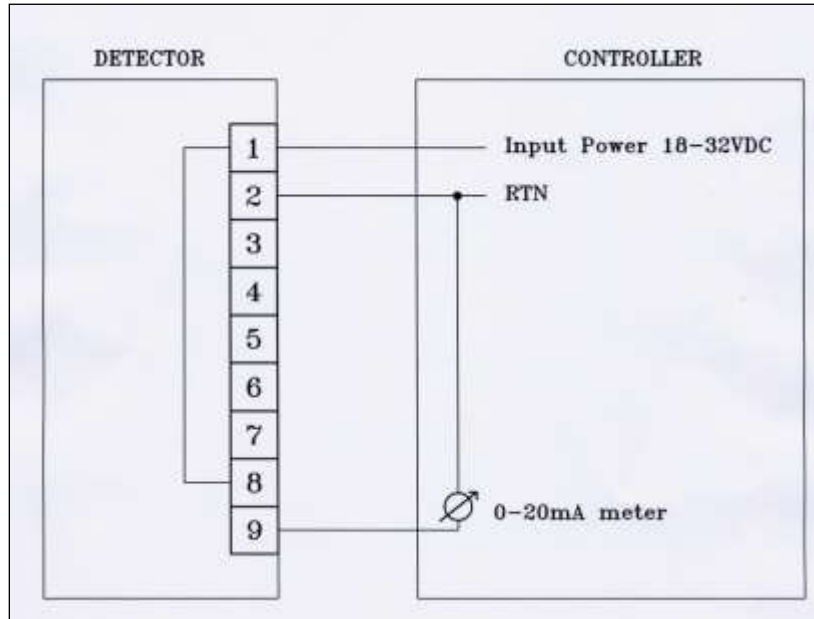
Wiring Option	Detector Model	Terminals		
		5	8	9
1	40/40M-1XXXX	Fault Relay (N.C.)	0–20mA (Sink)	0–20mA (Sink)
2	40/40M-2XXXX	Fault Relay (N.C.)	Alarm Relay (N.C.)	0–20mA (Source)
3	40/40M-3XXXX	Fault Relay (N.O.)	Alarm Relay (N.C.)	0–20mA (Source)
4	40/40M-4XXXX	Fault Relay (N.C.)	Auxiliary Relay (N.O.)	Auxiliary Relay N.O.
5	40/40M-5XXXX	Fault Relay (N.O.)	Auxiliary Relay (N.O.)	Auxiliary Relay N.O.



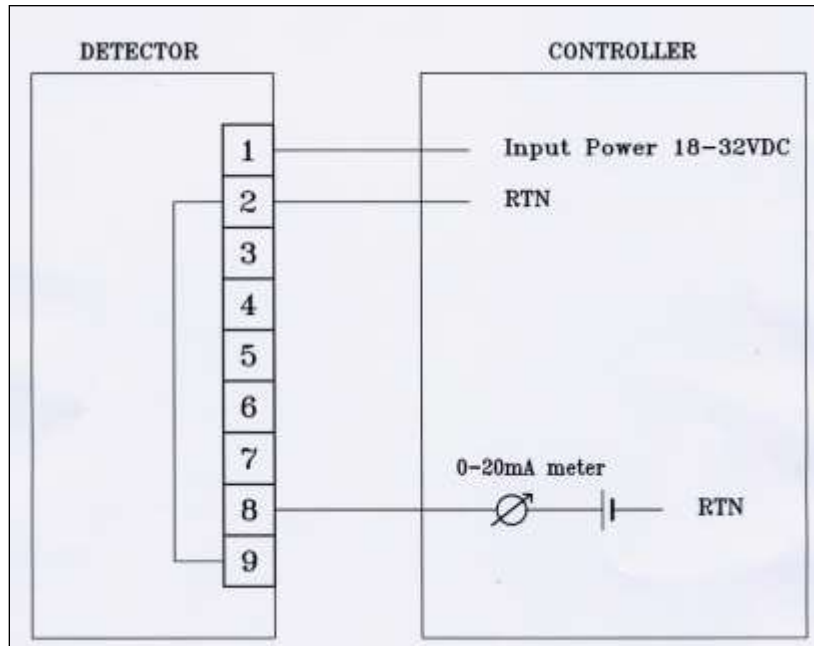
**Figure 10: Typical Wiring for 4 Wire Controllers (Using Option 1 or 2 Wiring)**



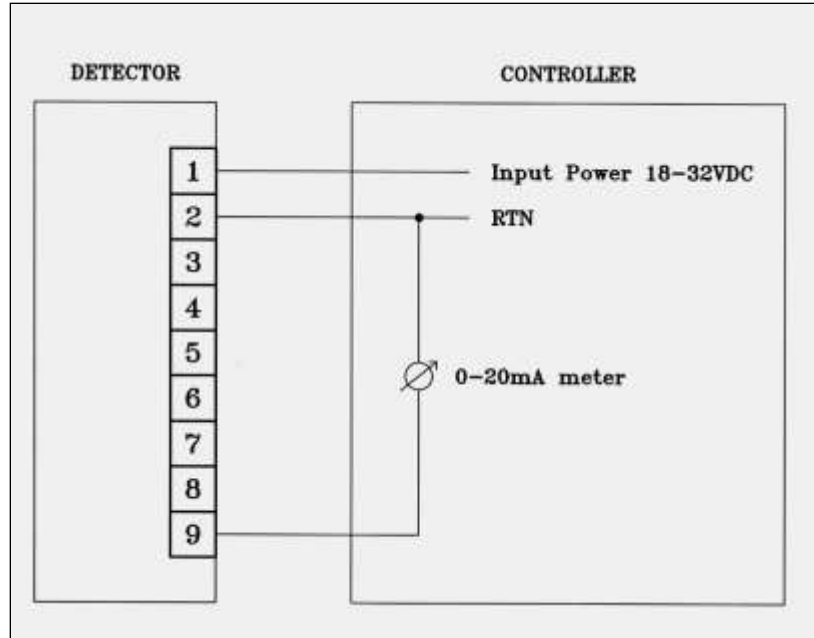
**Figure 11: 0-20mA Wiring Option 1 (Sink 4-Wire) - Default**



**Figure 12: 0-20mA Wiring Option 1 (Converted to Source 3-Wire)**



**Figure 13: 0-20mA Wiring Option 1 (Non-isolated Sink 3-Wire)**



**Figure 14: 0-20mA Wiring Option 2 and 3 (Source 3-Wire available with the HART Protocol)**



**Note:**

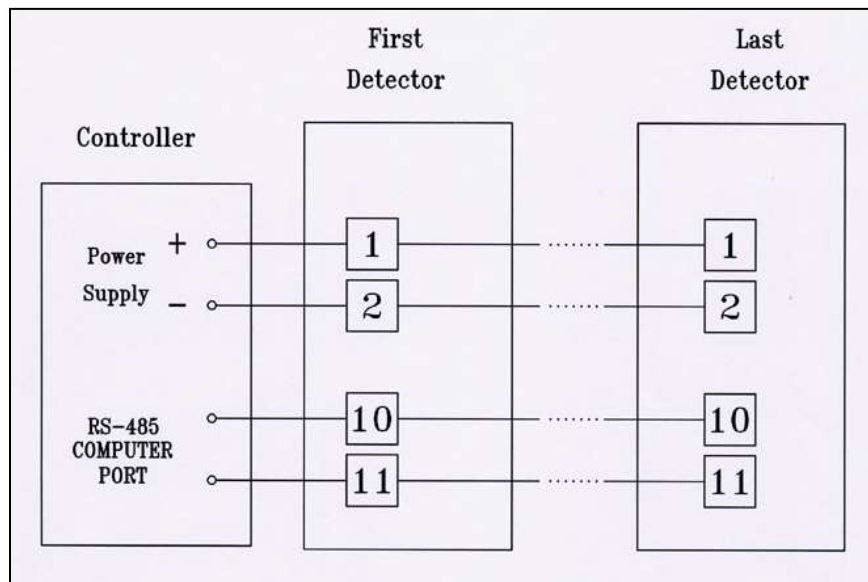
There are no 0-20mA outputs in wiring options 4 and 5.

## Appendix C: RS-485 Communication Network

### C.1 RS-485 Overview

By using the RS-485 network capability of the Multi IR detector and additional software, it is possible to connect up to 32 detectors in an addressable system with 4 wires only (2 for power and 2 for communication). Using repeaters, the number of detectors can be much larger (32 detectors for each repeater) up to 247 on the same 4 wires. When using the RS-485 network, it is possible to read each detector status (FAULT, WARNING, and ALARM) and to initiate a BIT for each detector individually.

For more details, contact SPECTREX.



**Figure 15: RS-485 Networking**



## Appendix D: Accessories

This appendix describes the accessories that can help you maximize fire detection with the SharpEye Multi IR Flame Detector:

### D.1 Flame Simulator FS-1400

The Flame Simulator FS-1400 is designed specifically for use with SharpEye Flame Detectors. The Flame Simulator emits IR radiation in a unique sequential pattern corresponding to and recognizable by the detector as fire, which allows the detectors to be tested under simulated fire conditions without the associated risks of an open flame.



**Figure 16: Flame Simulator FS-1400**

#### D.1.1 Ordering Information

The P/N of the Flame Simulator Kit is 380114-4.

The kit is supplied in a carry case that includes:

- Flame Simulator FS-1400
- Charger
- Tool Kit
- Technical *Manual TM380302*

## D.1.2 Unpacking

Verify that you have received the following contents:

- Delivery form
- Flame simulator with integral battery
- Tool keys
- User manual
- FAT forms
- EU declaration
- Storage case

## D.1.3 Operating Instructions

---

**Warning:**

Do not open the flame simulator to charge the batteries or for any other reason in a hazardous area.

---

**Caution:**

The following test simulates a real fire condition and may activate the extinguishing system or other alarms. If activation is not desired, disconnect/inhibit them before the test and reconnect after the simulation.

---

**■ To simulate a fire:**

- 1** Verify you are at the correct distance from the detector according to the type of detector and the detector sensitivity.
- 2** Using the mechanical sight, aim the flame simulator toward the center of the detector.
- 3** Push the activate button, and then use the laser spot for fine adjustment toward the center of the detector.
- 4** Keep the simulator aimed at the detector for up to 50 seconds, until you trigger an alarm.
- 5** Wait 20 seconds before repeating the test.



## D.1.4 Range

**Table 28: Sensitivity Ranges**

Sensitivity	Detection Range (ft/m)	Standard Test Range (ft/m)
1 (Low)	50/15	6.6/2
2	100/30	19.6/6
3	150/45	29.5/9
4 (High)	215/65	39.3/12


**Notes:**

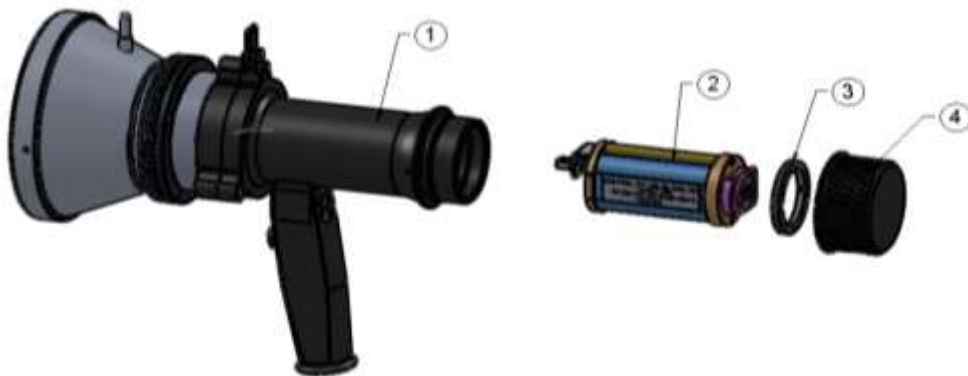
- The minimum distance from the detector is 30"/75cm.
- At extreme temperatures, there is a 15% maximum reduction in the range.


**Warning:**

Keep the flame simulator in a safe place when not in use.

## D.1.5 Charging the Battery

The flame simulator uses lithium-ion batteries as a rechargeable power source. When the batteries are fully charged, the simulator operates at least 1,000 times without having to be recharged. The simulator will not operate when the voltage from the batteries is lower than the required operational level.



<b>1</b>	Simulator	<b>3</b>	Locking Disc
<b>2</b>	Battery Pack	<b>4</b>	Back Cover

**Figure 17: Flame Simulator Battery Replacement**

- **To charge the battery:**

**Caution:**

Place the flame simulator on a table in a safe area, not exceeding 104°F/40°C.

---

- 1 Release the locking screw.
- 2 Unscrew the battery back cover (Item 4) counterclockwise.
- 3 Unscrew the locking disc (Item 3) clockwise.
- 4 Pull out the battery from the flame simulator.
- 5 Connect the battery to the charger.
- 6 Charge for a maximum of 2–3 hours.
- 7 Disconnect the charger.
- 8 Insert the battery into the Flame Simulator.
- 9 Screw on the locking disc (Item 3).
- 10 Screw on the back cover (Item 4).
- 11 Lock the back cover with the locking screw.

## D.1.6 Battery Replacement

- **To replace the battery:**

**Note:**

The item numbers shown in this procedure can all be found in Figure 17.

---

- 1 Place the flame simulator on a table in a safe area, not exceeding 104°F/40°C.
- 2 Release the locking screw.
- 3 Unscrew the battery back cover (Item 4) counterclockwise.
- 4 Unscrew the locking disc (Item 3) clockwise.
- 5 Pull out the battery from the flame simulator.
- 6 Insert the new battery pack in the simulator housing. Use only SPECTREX battery pack, P/N 380004.
- 7 Screw on the locking disc (Item 3).
- 8 Screw on the back cover (Item 4).
- 9 Lock the back cover with the locking screw.

**Note:**

For more information refer to *TM380302*.

## D.2 Technical Specifications

### D.2.1 General

- **Temperature Range:** -4°F to +122°F / -20°C to +50°C
- **Vibration Protection:** 1g (10-50Hz)

### D.2.2 Electrical

- **Power:** 14.8V (4 X 3.7V rechargeable lithium-ion battery)
- **Max. Current:** 4A
- **Battery Capacity:** 2.2AH
- **Charging Time:** 2A at 2hr

### D.2.3 Physical

- **Dimensions:** 230 x 185 x 136 mm
- **Weight:** 5.5lb/2.5kg
- **Enclosure:** aluminum, heavy duty copper free, black zinc coating
- **Explosion proof enclosure:**
  - ATEX & IECEX
  - Ex II 2 G D
  - Ex d ib op is IIB +H2 T5 Gb
  - Ex ib op is tb IIIC T135°C Db
  - 20°C to +50°C / -4°F to +122°F

## D.2.4 EMI Compatibility

**Table 29: Immunity Tests**

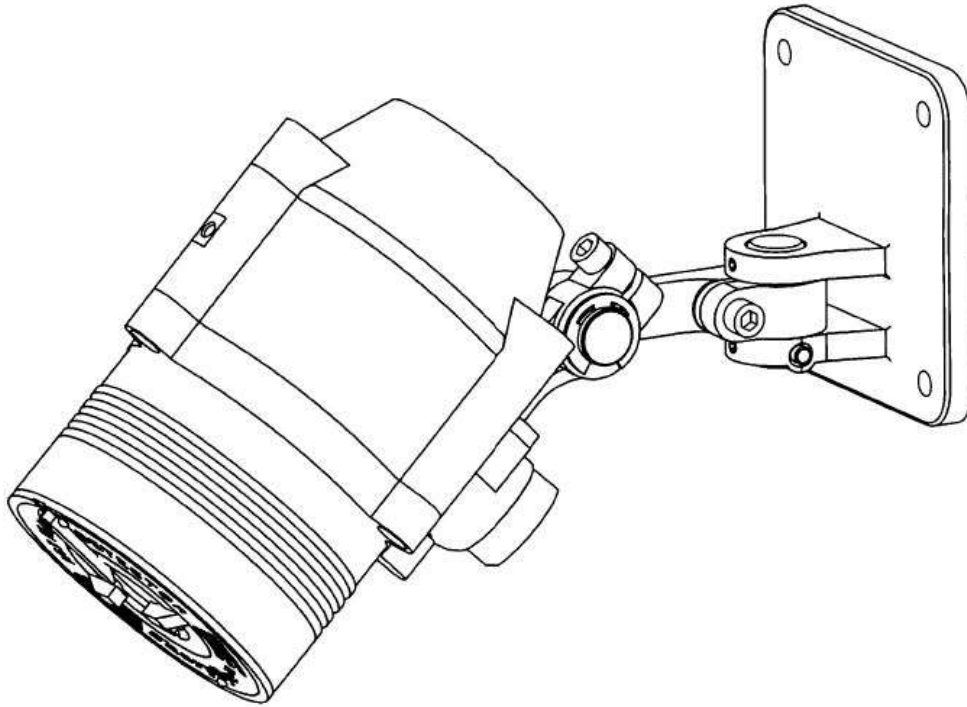
Immunity Tests		
Title	Basic Standard	Level to be tested
Electrostatic Discharge (ESD)	IEC 61000-4-2	6kV/8kV contact/air
Radiated Electromagnetic Field	IEC 61000-4-3	20V/m (80MHz-1GHz) 10V/m (1.4-2GHz) 3V/m (2.0-2.7GHz)
Conducted Disturbances	IEC 61000-4-6	10Vrms (150kHz-80MHz)
Immunity to Main Supply Voltage Variations	MIL-STD-1275B	

**Table 30: Emission Tests**

Emission Tests			
Title	Basic Standard	Level to be Tested	Class
Radiated Emission	IEC 61000-6-3,	40dbuv/m (30-230MHz), 47dbuv/m (230MHz-1GHz)	Like Class B of EN 55022

### D.3 Tilt Mount

The tilt mount (P/N 40/40-001) provides accurate directional selection for optimum area coverage.



**Figure 18: Tilt Mount**

## D.4 Duct Mount

The duct mount (P/N 777670) is suitable for use with the SharpEye 40/40 Series Optical Flame Detector 40/40M, for both the aluminum and st.st. enclosure.

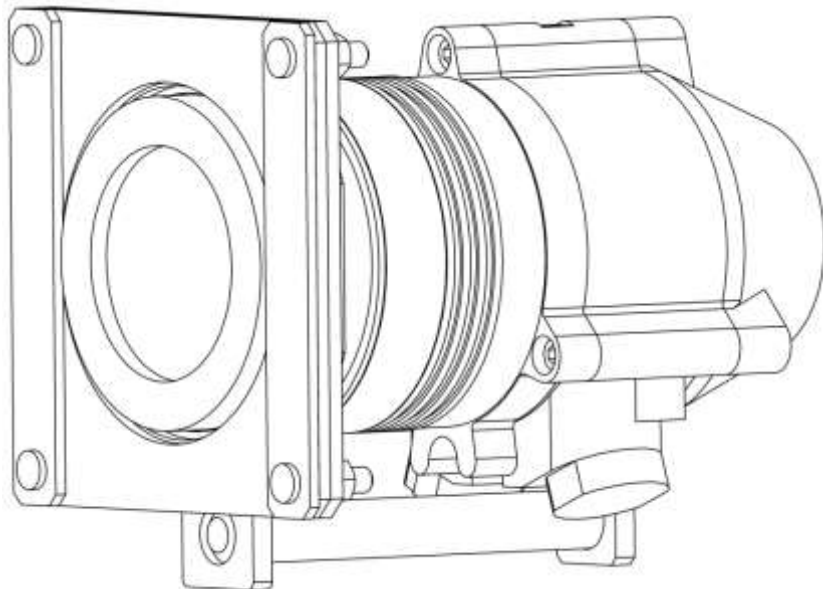
The duct mount allows flame detection in areas where high temperatures exist or where the detector cannot be installed inside the area. It comprises a special duct mount arrangement with a specific optical window to allow installation in high-temperature duct applications.

The duct mount limits the cone of vision of the installed detector to 65° horizontal and 65° vertical.

The temperature allowed for the duct mount to be installed is:

-55°C to +200°C / -67°F to +392°F.

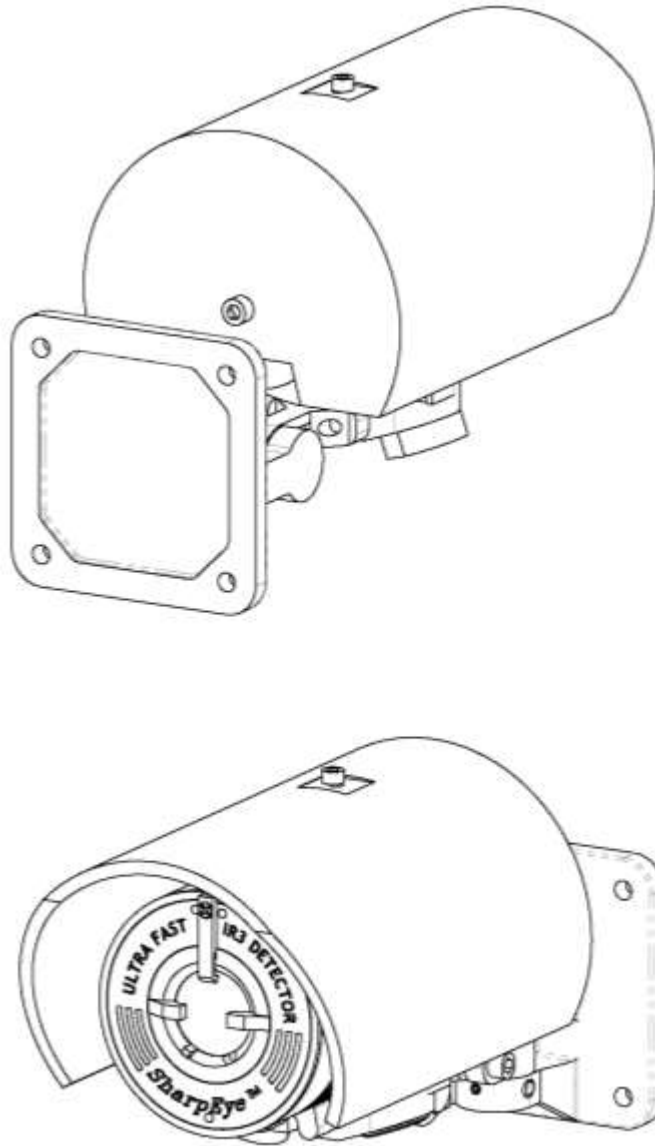
For more instructions refer to TM777670.



**Figure 19: Duct Mount**

## D.5 Weather Cover

The weather cover (P/N 777163) protects the detector from different weather conditions, such as snow and rain.



**Figure 20: Weather Cover**

## D.6 Air Shield

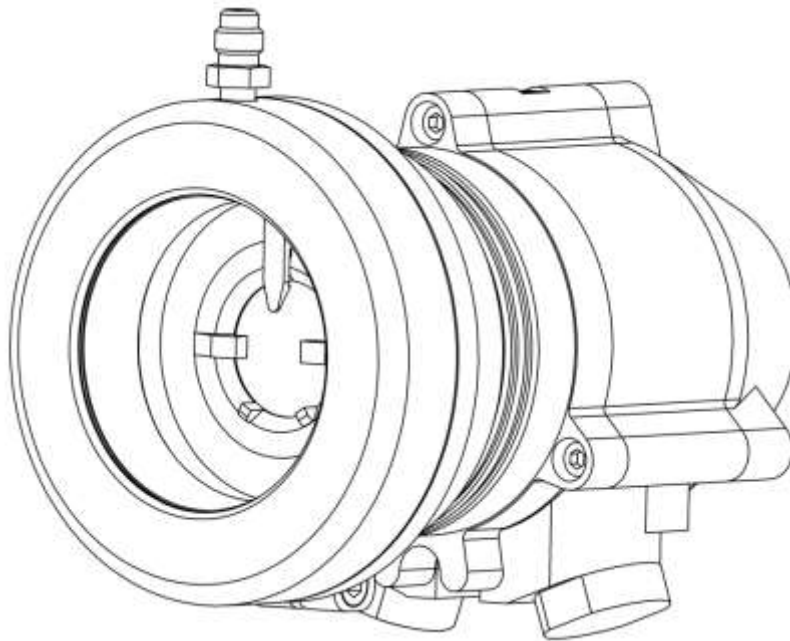
The air shield (P/N 777650) is suitable for use with the SharpEye 40/40 Series Optical Flame Detector 40/40M, for both the aluminum and St.St. enclosures.

Optical flame detectors are often used in highly polluted or dirty areas that force maintenance personnel to access the detector frequently in order to clean its optical window. The special air shield, developed for SharpEye 40/40 series optical flame detectors, allows their installation under environmental conditions where they may be exposed to oil vapors, sand, dust, and other particulate matter.

The temperature of the air supply to the air shield should not exceed 60°C/140°F at any time.

- **Air pressure source:** Clean, dry, and oil-free air
- **Pressure:** 2–3 bar / 30–45 psi
- **Fitting:** 7/16" – 20UNF-2A
- **Operation Temperature:** -55°C to +85°C / -67°F to +185°F

For more instructions, refer to *TM777650*.



**Figure 21: Air Shield**



## Appendix E: SIL-2 Features

### E.1 40/40M Flame Detector

This appendix details the special conditions for compliance with the requirements of EN 61508 for SIL 2.

The 40/40M Flame Detector can be used in low or high demand mode applications. See IEC 61508.4, Chapter 3.5.12.

#### E.1.1 Safety Relevant Parameters

Perform the following functional checks of the detector:

##### E.1.1.1 Alternative 1: Functional check of the detector every 180 days

- **HFT:** 0
- **PFD:**  $3.4 \times 10^{-4}$  ( $\approx 3.3\%$  of SIL-2) if only alarm relay is used for alerting
- **PFD:**  $3.6 \times 10^{-4}$  ( $\approx 3.6\%$  of SIL-2) if 0–20mA interface is used as alarm.
- **PFH:**  $1.6 \times 10^{-7}$  1/h ( $\approx 16.4\%$  of SIL-2) for 0–20mA application.
- **SFF:** 95% fulfills the conditions of EN 61508 for SIL2

##### E.1.1.2 Alternative 2: Functional check of the detector every 365 days

- **HFT:** 0
- **PFD:**  $5.2 \times 10^{-4}$  ( $\approx 5.1\%$  of SIL-2) if only alarm relay is used for alerting
- **PFD:**  $5.6 \times 10^{-4}$  ( $\approx 5.6\%$  of SIL-2) if 0–20mA interface is used
- **PFH:**  $1.6 \times 10^{-7}$  1/h ( $\approx 16.4\%$  of SIL-2) for 0–20mA application
- **SFF:** 95% fulfills the conditions of EN 61508 for SIL2.

#### E.1.2 Guidelines for Configuring, Installing, Operating, and Service

The alert conditions according to SIL 2 can be implemented by an:

- Alert signal via 20mA current loop  
Or
- Alert signal via alarm relay and the fault relay  
Or
- Alert signal via analog output interface.

##### E.1.2.1 Conditions for Safe Operating

- The flame detector must consist only of the approved hardware and software modules.

- The 24V power supply must fulfill the requirements for PELV/SELV of EN 60950.
- The automatic BIT (Built-In-Test) must be activated.
- The setup parameters must be verified (as described in *Using the 0–20mA Interface for Alerting* on page 81 and *Using the Alarm Relay Contact for Alerting* on page 82. The function of the 40/40 Flame Detector (flame detection, function of the 0–20mA interface, and relay functions) must be checked completely.

#### **E.1.2.2 Using the 0–20mA Interface for Alerting**

- The following parameters should be set:
  - Automatic BIT test = on
  - Connected to 0–20mA Terminals
- The following allowed output current must be supervised with an accuracy of  $\pm 5\%$ :
  - Normal State = 4mA
  - Warning State = 16mA
  - Alarm State = 20mA
- The receiving device must be programmed to indicate a fault condition when current levels reach overcurrent or undercurrent.
- The 0–20mA can be used as low and high demand mode.

#### **E.1.2.3 Using the Alarm Relay Contact for Alerting**

- The following parameters should be set:
  - Automatic BIT Test = on
  - Connected to N.C. contact of alarm relay terminals
  - Connected to fault relay terminals
- The relay contacts ("alarm" and "faulty relay") must be protected with a fuse rated at 0.6 of the nominal specified relay contact current.
- The maximum contact rating that is allowed per SIL-2 is 30VDC.
- The contact of the alarm relay opens if there is a fire alarm.
- During the forwarding and evaluation of the alarm, the relay contact opens.
- The alarm relay can be used as low demand only.

#### **E.1.2.4 Other**

- The complete function of the flame detector (flame detection, function of the 0–20mA interface, the relays, and the analog output interface) must be examined at least every 6 or 12 months (see *Safety Relevant Parameters* on page 81), or whenever the flame detector must be switched off and on.
- The window of the sensor must be examined at appropriate time intervals for partial contamination.

**Caution:**

The HART and the RS-485 interfaces must not be used for the transmission of safety-related data.

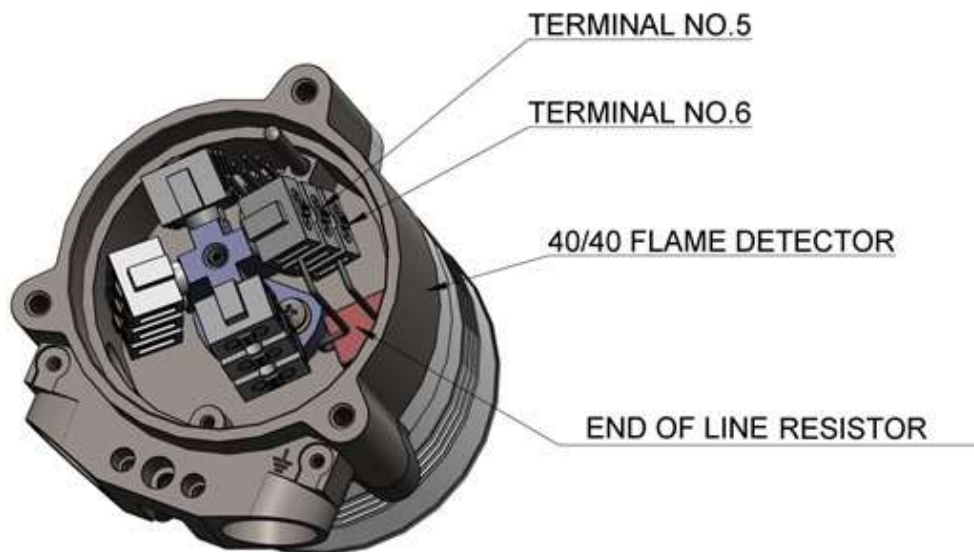
---

## Appendix F: End of Line Resistor

The 40/40 series can be equipped with an EOL resistor inside the flameproof 'd' terminal compartment.

The EOL resistor can be situated in the rear part which is Ex e or Ex d , depending on the application. When the resistor is assembled, the rear part can be used as Ex d only.

To meet the allowed power consumption, the total resistance should be higher than 1.5K $\Omega$ .



**Figure 22: End of Line Resistor Assembly**







# Technical Support

For technical assistance or support, contact:



8200 Market Blvd  
Chanhassen, MN 55317  
USA

Phone: +1 (973) 239 8398

Email: [spectrex@spectrex.net](mailto:spectrex@spectrex.net)

Website: [spectrex.csc.rmtna@emerson.com](http://spectrex.csc.rmtna.emerson.com)