

# **A Guide to Ergonomics**

Sydney Cheryl Sutton  
Editor



N.C. Department of Labor  
Division of Occupational Safety and Health  
4 W. Edenton St.  
Raleigh, NC 27601-1092

Cherie K. Berry  
Commissioner of Labor

**N.C. Department of Labor  
Occupational Safety and Health Program**

Cherie K. Berry  
Commissioner of Labor  
*OSHA State Plan Designee*

**Acknowledgments**

This edition of *A Guide to Ergonomics* is largely based on a earlier edition written by the L. A. Weaver Company of Raleigh, North Carolina. The L. A. Weaver Company specializes in occupational and environmental safety and health and ergonomics.

The editor gratefully acknowledges the review and suggestions provided by G. Robert Smith, Occupational Health Consultant–Ergonomist, and Danny W. Sullivan, Industrial Hygiene Consultant, with the North Carolina Division of Occupational Safety and Health.

**To obtain additional copies of this book, or if you have questions about N.C. occupational safety and health standards or rules, please contact:**

**N.C. Department of Labor  
Bureau of Education, Training and Technical Assistance  
4 W. Edenton St.  
Raleigh, NC 27601-1092**

**Phone: (919) 807-2875 or 1-800-NC-LABOR**

---

Additional sources of information are listed on the inside back cover of this book.

---

The projected cost of the OSHNC program for federal fiscal year 2002–2003 is \$13,130,589. Federal funding provides approximately 37 percent (\$4,920,000) of this total.

Printed 2/98, 4M



# Contents

<b>Part</b>		<b>Page</b>
	Foreword .....	v
	Introduction.....	vi
1	Applied Anthropometry.....	1
	Introduction .....	1
	Application of Anthropometric Data ....	1
	Example Applications of Anthropometric Data .....	2
2	Biomechanics .....	4
	Introduction.....	4
	Equipment.....	4
	Types of Movements of Body Members.....	5
	Muscles .....	6
	Levers.....	6
3	Illumination.....	10
	Introduction .....	10
	The Nature of Light .....	10
	Kinds of Light Sources Used in the Industrial Environment .....	14
4	Cumulative Trauma Disorders .....	15
	Introduction.....	15
	Carpal Tunnel Syndrome .....	16
	Other Cumulative Trauma Disorders... ..	18
	Corrective Actions .....	19
	Medical Treatment of Cumulative Trauma Disorders.....	20
	Hand Tools .....	20

5	Seating.....	24
	Introduction.....	24
	Proper Sitting Positions .....	24
	General Principles.....	24
	Guidelines to Chair Adjustment.....	25
	Sit-Stand Chair .....	27
	Balens Chair .....	27
6	Physical Space Arrangements .....	29
	Introduction.....	29
	Visual Considerations.....	31
	Work Area Design .....	32
7	Minimization of Manual Materials	
	Handling .....	34
	Introduction.....	34
	Mechanical Aids .....	35
	Determining Lifting Limits .....	36
	The Effect of an Abdominal Belt.....	40
	Personal Lifting Monitors .....	41
8	Workers with Disabilities—Ergonomic	
	Considerations .....	42
	Introduction.....	42
	Americans with Disabilities Act	
	of 1990.....	42
9	Visual Display Terminals.....	45
	Introduction.....	45
	Workstation Design .....	46
	Summary .....	52
	Endnotes .....	53

# Foreword

One North Carolina worker may spend the day sitting at a desk in an office. Another may walk the factory floor, moving heavy boxes. Ergonomics plays a major role in every worker's day, no matter how or where work is done.

To stay safe and healthy on the job, everyone must move, lift, sit, and perform various tasks in ways that do not strain muscles, damage the spinal column, or cause carpal tunnel syndrome.

This detailed guide can help working people avoid ergonomic distress. It can assist employers in making their workplaces more comfortable to employees and more productive. The information in this guide ranges from basic advice to detailed formulas that will help safety and health professionals design better work stations.

The North Carolina Department of Labor has administered the Occupational Safety and Health Act of North Carolina for more than 20 years. This act and its resulting standards are commonly called OSHA. The act mirrors federal OSHA law and provides North Carolina workers with protections equal to or greater than those provided under the federal act. As the agency charged with administering this act, the department enforces state laws relating to occupational safety and health.

However, OSHA's mission is greater than just to enforce regulations. A second, but equally important, goal is to help the public find ways to create safe workplaces. Everyone profits when managers and employees work together for safety. This guide, like the many other educational materials produced by this department, can help.

Reading and using *A Guide To Ergonomics* will help you find and correct ergonomic problems where you work.

Cherie K. Berry  
Commissioner of Labor

# Introduction

Ergonomics is the study of people while they use equipment in specific environments to perform certain tasks. Ergonomics seeks to minimize adverse effects of the environment upon people and, thus, enable each person to maximize his or her contribution to a given job.

This industry guide:

- Explains, generally, how measurements of human traits can be used to further workplace safety, health, comfort, and productivity.
- Discusses how to enhance worker safety by combining principles that govern the action of forces with knowledge of the human body.
- Analyzes properties of illumination and explains how proper illumination makes for a safer workplace by reducing worker fatigue.
- Shows how hand tools can be designed to reduce injuries to employees and to lessen trauma to their body members.
- Illustrates ways to recognize proper sitting positions and to construct seating arrangements to minimize stress to the lumbar region.
- Demonstrates how workspaces can be designed to decrease psychological stress and to increase employee motivation.
- Directs attention to the benefits of proper selection and strategic arrangement of controls and displays for the machinery operation.
- Offers general information about ways to reduce back injuries which result from manual lifting and offers more specialized guidelines for evaluating physical stresses imposed by lifting.

- Refines the concept of the worker with a disability and suggests ways of meeting the special needs of persons with disabilities.
- Stimulates new thinking about problems (such as those from the sustained operation of computers) brought about by technological advancements.

This industry guide demonstrates how benefits are derived from applying the principles of ergonomics to workplace safety and health. It gives the reader a solid starting point from which to seek new solutions to occupational safety and health problems.

Endnotes which are referenced in the guide's text appear in the back of the book.

**This guide is intended to be consistent with standards adopted or promulgated under the Occupational Safety and Health Act of North Carolina. If information is considered by the reader to be inconsistent with any standard, then the standard should be followed.**

# 1

## **Applied Anthropometry**

### ***Introduction***

The workplace should be designed to accommodate the body size of the user. Anthropometry is the measure of physical human traits that is applied to determine allowable space and equipment size and shape used for the work environment. Factors which are considered include agility and mobility, age, sex, body size, strength, and disabilities. Engineering anthropometry applies these data to tools, equipment, workplaces, chairs, and other consumer products, including clothing design. The goal is to provide a workplace that is efficient, safe, and comfortable for the worker.

### ***Application of Anthropometric Data***

Because one can seldom accommodate the entire range of body sizes in the worker population, it is necessary to apply anthropometric data to accommodate the majority. It is common to design for 90 to 95 percent of anthropometric dimensions. Accommodating 95 percent of body sizes eliminates the smallest 2.5 percent and the largest 2.5 percent from consideration.

Designing for the “average person” is a serious error and should be avoided whenever possible. It may be necessary to design for the tallest individuals (95th percentile) to determine leg room under a table, or for the shortest individuals (5th percentile) for reach capability. Although the “average person” is a myth, certain equipment and facilities are designed using average values. Supermarket counters and shopping carts are illustrations.



# ***Example Applications of Anthropometric Data***

## **Controls**

In the design of controls, the size of the operator's hand must be considered. Important hand dimensions include the circumference of the hand, breadth of the hand, circumference of the wrist, and the maximum grip (See figure 1). Knobs, for example, must consider these dimensions so they fit the hand comfortably and turn easily.

**Figure 1**

### ***Important Hand Dimensions***

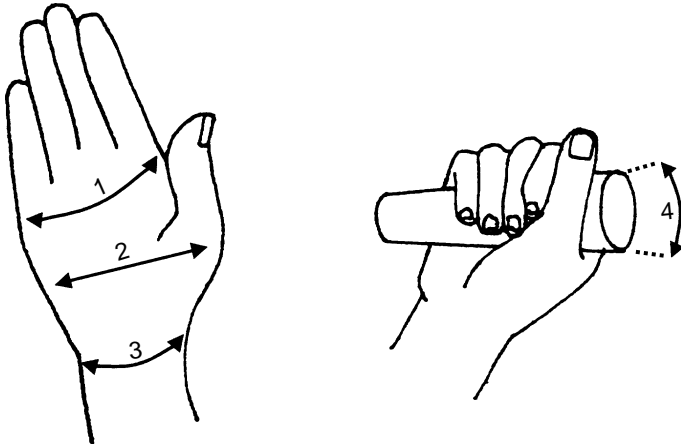

- 1—Circumference of hand
- 2—Breadth of hand
- 3—Circumference of wrist
- 4—Maximum grip (circumference of thumb and forefinger)

## **Workstation Designs**

The design of workstations should be based upon anthropometric data, behavioral patterns of employees, and specific requirements of the work being done. For example, the height at which work takes place is important in designing workstations. Work should be located

to suit the height of the operator, whether sitting or standing. If the work is located too high, the neck and shoulders may suffer due to the shoulders frequently being raised to compensate for the incorrect height. If the work is located too low, a backache can result from required leaning and bowing the back. Adjustable work tables allow operators to determine a comfortable working height. Anthropometric dimensions can also be used in workplace layout to optimize vertical and horizontal reaches and grasps.

### **Machine Guarding**

If barriers are used to protect workers from hazardous machines, reach is limited by the length of the arm and, in the case of openings, by the size of the hands and fingers. The distance that a worker can reach may determine the minimum height of certain kinds of guards or the minimum distance of barriers from the machine which they guard.

The average limit of reach when on tiptoe is considered to be 7'11" (1). The International Labour Office has established 8'6" as the dividing line beyond which safety is assumed when standing and reaching upwards. When one reaches over a barrier, one is limited by the body at the point of contact with the barrier.

In general, an opening smaller than  $\frac{3}{8}$ "  $\times$   $\frac{3}{8}$ " cannot be reached through by a finger. If the opening will admit one to three fingers, reach will be restricted by the bases of the fingers. Therefore, the distance between a guard with such openings and the dangerous equipment does not need to be greater than the maximum length of the longest finger plus a clearance allowance.

The various distances involved in reaching around, above, and through barriers are important in determining what type of guards should be employed in protecting workers from hazardous equipment.

# 2

## **Biomechanics**

### ***Introduction***

Biomechanics is the study of the structural elements of the human body in relation to how the body functions and how much stress, acceleration, and impact it can stand. Simply defined, it is the application of the principles of mechanics to living biological material. Today, the total energy demanded from a person in the performance of an industrial task has often been drastically reduced through better engineering and technology. However, stress may be created in small components of the worker's anatomy. Ergonomists use information about the functional anatomy of the living body to eliminate, reduce, or manage such stresses. Ergonomists apply the principles of biomechanics to problems of occupational health, occupational safety, and industrial productivity.

### ***Equipment***

Improperly designed chairs or other poorly designed equipment may obstruct the blood flow to body tissues. It is essential that designers as well as the evaluators of tools and equipment be familiar with the location of blood vessels vulnerable to compression. Of special importance is a knowledge of the location of blood vessels and other pressure-sensitive anatomical structures in the hand. For example, poorly designed or improperly held hand tools may squeeze the hand's ulnar nerve, which can lead to numbness and tingling of the fingers. The simplest of hand tools, if designed without due consideration to biomechanical principles, can adversely affect the health of workers as well as their performance and productivity.

Even slight changes in the posture of a limb may affect the mechanical advantage at which muscles operate and hence their efficiency, to a considerable degree. Outward rotation of the forearm is a very important movement in industrial operation.

Outward rotation is employed, for example, when the right forearm and hand are used to close valves, tighten screws, and operate lathes. The effectiveness of the muscle is impaired when the angle between the forearm and upper arm is larger or smaller than the optimum of approximately 90 degrees.

### ***Types of Movements of Body Members***

Movements by the body during its performance of particular activities in industry can be described in operational terms:

- *Positioning* movements are those in which the hand or foot moves from one specific position to another, such as when reaching for a control knob.
- *Continuous* movements are those that require muscular control adjustments of some type during the movement, such as when operating the steering wheel of a car or guiding a piece of wood through a band saw.
- *Manipulative* movements involve the handling of parts, tools, and control mechanisms, typically with the fingers or hands.
- *Repetitive* movements are those in which the same movement is repeated. Hammering, using a screwdriver, and turning a handwheel are examples of repetitive movements.
- *Sequential* movements are relatively separate, independent movements in a sequence.
- A *static posture* involves maintaining a body segment in a specific position for a period of time.

The ability to describe movements of the body in such operational terms permits ergonomists to apply the principles of biomechanics to problems associated with workplace health, safety, and productivity.

## ***Muscles***

When any form of bodily activity calls for a considerable expenditure of effort, the necessary movements must be organized such that muscle power is used most effectively and skillfully. Since a muscle is most powerful at the beginning of its contraction, it is a good idea, in principle, to start from a posture in which the muscle is fully extended. There are so many exceptions to this general rule, however, that it has more theoretical than practical value. One must also take into account the leverage effect of the bones.

If several muscles join forces, exertion is usually at its greatest when as many muscles as possible contract simultaneously. The maximum force of which a muscle, or group of muscles, is capable depends upon: (a) age, (b) sex, (c) constitution, (d) state of training, and (e) momentary motivation.

Muscle power peaks, for both men and women, at between 25 and 35 years of age. Older workers, between 50 and 60 years of age, can produce only about 75 to 85 percent as much muscular power as during those peak years.

## ***Levers***

A lever is a simple machine used to perform work. It consists of a long object, such as a rod or plank, and a braced object on which the rod rests. The braced, or fixed part, is called the fulcrum. The distance from the load to the fulcrum is known as the load arm. The distance between the fulcrum and the applied effort is the effort arm. A lever can be used to lift or move objects, faster or with less effort than would be possible without

the lever. Prying something loose with a crowbar is an example of using a lever. Levers are governed by a law of equilibrium, such that:

$$\text{Load} \times \text{Load Arm} = \text{Effort} \times \text{Effort Arm}$$

### **First-Class Levers**

First-class levers have the fulcrum placed between the load and the effort. Examples include the seesaw, crowbar, and the balance scale. If the two arms of the lever are of equal length, the effort must be equal to the load. In the instance of the crowbar, the effort travels farther than the load and is less than the load. A pair of scissors is a double lever of the first class. The first-class lever is illustrated in figure 2.

**Figure 2**

#### ***Examples of a First-Class Lever***

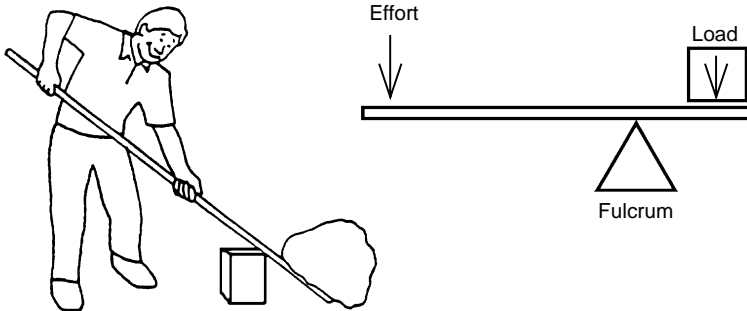

### **Second-Class Levers**

Second-class levers have the load between the effort and the fulcrum. A wheelbarrow is a second class lever. The wheel is the fulcrum, the handles take the effort, and the load is placed between the wheel and the effort (person doing the lifting). The effort always travels a greater distance and is less than the load. A nutcracker is a double lever of this class. The second-class lever is illustrated by figure 3.

**Figure 3**

***Examples of a Second-Class Lever***

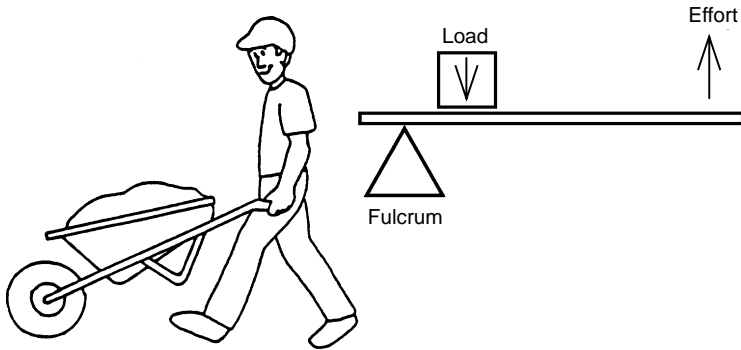

**Third-Class Levers**

Third-class levers have the effort placed between the load and the fulcrum. The effort always travels a shorter distance and must be greater than the load. The forearm is a third-class lever. When the hand is holding a weight, the weight is lifted by the biceps muscle of the upper arm, which is attached to the forearm near the elbow. The elbow joint is the fulcrum. The third-class lever is illustrated in figure 4.

**Figure 4**

***Examples of a Third-Class Lever***

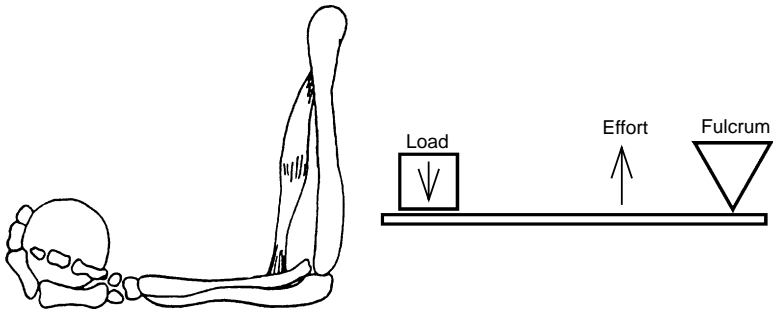

## **Relationship Between Speed and Power—Levers**

Power is lost in the same proportion that speed is gained. In a lever system, this relationship cannot be avoided. Some animals are thus more suited for speed, some for power. Horses, for example, with long legs and muscles acting close to the joints between legs and girdles, are well-suited for speed. Animals with short links and muscles that act farther away from the fulcrum, such as a bulldog, can better exhibit power.

This same relationship between speed and power presents itself as differences among people. Some workers are simply better equipped for lifting and carrying than are others. However, many of the lever systems within the human body are third-class levers and thus not especially suited for developing power. Therefore, lifting and carrying should be recognized as activities for which the human body is not particularly suited, and, wherever possible, these activities should be performed with the assistance of mechanical aids.



# 3

## **Illumination**

### ***Introduction***

Lighting of a sufficient intensity is essential to adequately perform visual tasks and to reduce worker fatigue. How a space is used and what it is used for influences how lighting should be applied. Other factors that influence lighting design for a task include appearance, economics, building costs, energy consumption, and the quality of lighting desired. Factors affecting the visual environment include lighting fixtures, visual tasks, lighting maintenance, lighting system design, and the individuals' eyesight.

### ***The Nature of Light***

The nature of light is determined by its quantity and quality. Light quantity is the amount of illumination cast upon the task and surrounding area. Light quality includes the color of the light, the direction and diffusion of the light, and the amount and type of glare from the light.

### **Quantity of Illumination**

The quantity of illumination relates to the amount of light that exists or is required at a workplace. The amount of light necessary for effective work depends on the nature of the work, the sharpness of a worker's vision, and the environment in which the work is done. The absolute minimum amount of light required for reading, writing, and many manual tasks is approximately one footcandle (2). As a reference point, a light in an indoor exit sign has at least five footcandles.

In the design of good lighting, safety and welfare should be taken into account as well as visual efficiency. In some jobs where visual demands are not great, it is normal for recommended levels of illumination to be based on safety, welfare, and amenity (creation of a pleasant environment). The minimal amenity level is 20 footcandles. When light levels fall below 20 footcandles, workers usually have a negative reaction to the lighting.

Too much light can be as damaging as too little. There is great variation between the amounts of illumination required by a younger worker and an older worker. The quantity of illumination needed depends upon the age of a person who must see to do the task, the reflecting characteristics present, the amount of light needed to do a task, and the speed and accuracy required of the person performing the task. As the illumination upon a task increases, so does the luminance (light reflected upward) and, as a result, the accuracy and speed of vision improves. The best ergonomic solution for these varying needs is to provide general workplace lighting and supplement it with specific task lighting.

Lighting systems should be designed to provide a uniform distribution of light over the entire work area. To ensure that a given illumination level will be maintained, give more light initially than is minimally required. The reason for this is that such factors as dirt, use, and time deteriorate lighting.

At any given time, most people have lights that appear dull and which no amount of cleaning will improve. Generally, this happens when 80 percent of the stated life of the bulb or light has been used. The best ergonomic solution is to replace it at this point.

Tables exist to provide the recommended levels of illumination for visual performance of young adults with normal vision. The IES Lighting Handbook provides such data for various industries. Illumination

recommendations are intended as guides for lighting levels from an overall operational standpoint. The lighting levels are not recommended in order to ensure safety and are not, therefore, a basis for regulatory minimum illumination.

### **Quality of Illumination**

The quality of illumination pertains to the distribution of brightness in a visual environment. A good quality of illumination means that all brightness contributes favorably to visual performance, visual comfort, ease of seeing, safety, and aesthetics for the specific visual task involved.

A worker can normally see the task itself, the immediate background to the task, and the general surroundings. The eyes tend to be attracted to the brighter and more colorful parts of the field of vision. Therefore, light and color can be used to direct the focus of attention to the task. Lighting should be directed to the work, or special local lighting should be provided to match the needs of the work and the general lighting levels.

The level of brightness required for any task is determined by the degree of detail the operator has to meet, the time allowed for seeing, and the reflection characteristics of the task. The general level of brightness in the room also contributes to the level of brightness required for a task. In practice, it is advisable to plan the illumination first in relation to what the operator requires to accomplish the task and then to plan the brightness of the other parts of the room to provide proper emphasis, visual comfort, and interest (3).

Poor quality industrial illumination is easy to recognize. It presents uncomfortable and hazardous situations. Certain tasks, such as distinguishing fine details, require higher quality illumination than do others. Also, work areas in which visual tasks are severely demanding and which are performed over a prolonged period of time require higher quality illumination.

Slight glare conditions may result in a loss of seeing efficiency and undue fatigue. Some factors that affect the quality of light include glare, shadows, colors, veiling reflections, and luminance distribution.

### **The Effect of Glare on the Quality of Light**

Glare is a disturbance of the retina's ability to adapt to amounts of light. It may cause discomfort or reduce the ability to see, or both. It occurs when some parts of the field of view are excessively bright in relation to the general level of brightness. A common example is presented by a person who is trying to watch a television set in a bright room. The ergonomic solution is to lower the lighting in the room.

The degree of glare resulting directly from light sources depends on such factors as the brightness and sizes of the sources, their position in the operator's field of view, and the average brightness of the surroundings against which they are seen. Glare can cause discomfort without affecting the operator's ability to see the work, especially in very bright surroundings. Ensuring that lights are placed above the line of sight will help eliminate glare.

There are three major types of glare. They are absolute, adaptive, and relative glare. Absolute glare exists when luminosity is so high that adaptation is impossible. Adaptive glare exists when adaptation to a certain amount of light has not yet been reached. Relative glare is present when there is too much of a contrast in the visual field.

In addition, glare can be classified as direct or specular. Direct glare results from a light source, whereas specular glare is created by reflection from a bright surface.

Direct glare can be reduced by:

- Avoiding bright light sources within 60 degrees of the center of the visual field.

- Using shields, hoods, and visors to keep the direct light source out of the viewers' eyes.
- Using indirect lighting.
- Using several low intensity sources of light rather than one high intensity source.

Specular glare can be reduced by:

- Using diffuse light.
- Using a dull matte surface (flat paints, desk blot-  
ters) rather than polished surfaces.
- Arranging direct light sources so that the viewing  
angle to the work is not equal to the angle of inci-  
dence from the source.

## ***Kinds of Light Sources Used in the Industrial Environment***

Daylight and electrical light are the two major sources of light used in industrial sites. Artificial light is commonly used in industrial buildings during day-  
time to provide additional local lighting on the work to provide special effects, such as modeling, silhouettes, and specular reflections, or to illuminate surfaces inac-  
cessible to the daylight. There are many instances where the amount of daylight in a building is inade-  
quate or obstructed, and artificial lighting may be required as permanent supplement to daylight. Daylight, however, is by far the best light source if it is available.

There are many different types of electrical light sources, and the choice for any particular situation depends upon the level of illumination required and the standard of color judgment involved in the visual task. Economic factors also influence the selection of electri-  
cal light sources.

# 4

## **Cumulative Trauma Disorders**

### ***Introduction***

Musculoskeletal injuries caused by working are common. The majority of these injuries are not accident-related broken bones or strained ligaments. They usually develop over a period of time as a result of repeated stress on a particular body part. The condition is often ignored until the symptoms become chronic and permanent injury occurs. Cumulative trauma disorders (CTDs) and repetitive motion injuries are terms used to refer to certain musculoskeletal injuries.

A key reason for the increase in CTDs is the increase in production due to automation. The assembly line, computerized office machines, and electronic checkout stations in grocery stores are examples of workstations that require a high volume of output. One simple, strain-producing task may be repeated several thousand times a day. High production demands do not allow much time for rest and recovery.

The aging work force relates to the incidence of CTDs because the ability to withstand shock, chronic strain, and stress decreases as an individual ages. Also, awareness of the causes and nature of CTDs has increased. Employers and employees can recognize tasks that cause or contribute to these disorders.

Recent studies have shown that a great deal of workers' compensation costs are due to CTDS. CTDs are responsible for many cases of lost work time. Early detection of CTDs can be difficult because the disorders often develop slowly over months or years. Therefore, preventing CTDs is important. Prevention can, in part, be accomplished by tool and workstation redesign and better work methods.

## ***Carpal Tunnel Syndrome***

Carpal Tunnel Syndrome (CTS) is a common nerve CTD. Workers, from aircraft assemblers to office assistants, are at risk for CTS. It is a progressively disabling and painful condition of the hand. CTS results from injury to the median nerve, which is located in the wrist. It is a nerve entrapment that develops from the buildup of pressure on the median nerve as it passes through the carpal tunnel. This is a dime size passage between the carpal (wrist) bones and the anterior transverse carpal ligament. Since musculoskeletal strain from repeatedly flexing the wrist or applying arm-wrist-finger force does not cause observable injuries, it often takes months or years for workers to detect damage.

Symptoms of CTS include weakness, clumsiness, numbness, pain, tingling, and a lack of sweating in parts of the hand innervated by the median nerve. CTS has been reported to occur from two to ten times as frequently in women as in men. The condition is progressive and can lead to compensable hand disabilities.

In the early stages, the signs and symptoms of CTS may be fleeting, intermittent, and vague. One of the first symptoms is awakening at night because the hand is aching, tingling, and numb. The term “nocturnal numbness” is often applied to CTS because symptoms are often severe during sleep. CTS usually affects the dominant hand. These symptoms may continue for months or even years. The patient may attribute the strange feelings to poor circulation from having slept on his or her hand during the night. At first, rubbing or shaking the hand can make the feelings go away. Gradually though, the feelings begin to persist. As pressure on the median nerve mounts, the thumb and the first three ringers increase in numbness. The pain becomes more intense, sometimes spreading to the forearm and even up into the shoulder. Eventually as the

disease progresses, the person begins to lose control of the hand, and may drop things or be unable to turn a key in a lock.

CTS is considered an occupational disease, as it is often associated with the performance of particular repetitive tasks. The reason that some people develop this condition while others do not is not known. A higher incidence of CTS among the female population is difficult to explain. Smaller hands and wrists may be at more risk.

One study (4) found that the use of vibrating tools is strongly associated with CTS. Repetitive motion tasks which involve the wrists were also found to be associated with CTS. The use of vibrating tools may involve repetitive wrist movements. This association may partially relate to the link between vibration and CTS.

Tests used to determine the presence of CTS include:

*Phalen's wrist-flexion test.* The patient props his or her elbows on a table and allows the wrists to drop into complete flexion for 30 to 60 seconds. If paresthesia and numbness occur almost immediately, the test is considered positive.

*Forced wrist-flexion test.* The patient props his or her elbows on the table, one wrist is held and the other is in complete flexion for 20 to 30 seconds. If the patient has CTS, symptoms should occur immediately.

*Tinel's sign test.* A percussion hammer is used to tap the patient at the wrist crease. If the patient feels a tingling in the hand along the median nerve distribution, the test is positive.

*Electroneuromyography.* A physician performs this test, which requires an electromyograph and related equipment. Its purpose is to measure the median nerve's conduction velocity, the speed at which nerve impulses translate into muscle responses. If the velocity measures



5 milliseconds or more below normal, chances are the median nerve is compressed in the carpal tunnel. A negative result, however, does not rule out CTS since a median nerve may be compressed yet its conduction velocity may remain normal. Electroneuromyography is the most reliable of these tests used to determine the presence of CTS.

## ***Other Cumulative Trauma Disorders***

Although CTS is the best known of repetitive motion disorders, other disorders can also be disabling. Other CTDs include:

*Tenosynovitis.* Tenosynovitis is the inflammation of the tendons and sheaths. It is often associated with tasks demanding extreme wrist deviation. For example, wrist deviation is required to hold an in-line nut-runner in a horizontal position.

*Trigger finger.* Trigger finger is a form of tenosynovitis which results when any finger must be frequently flexed against resistance. It may be avoided by designing tool handles for operation by the thumb, by more than one finger, with lower force requirements, or by not requiring constant pressure.

*De Quervain's Disease.* In De Quervain's disease, the tendon sheath of both the long and the short abductor muscles of the thumb narrows. The disease is common among women workers, particularly those who perform repetitive manual tasks involving radial or inward hand motion and firm grips.

*Tennis Elbow.* Also called epicondylitis, this form of tendinitis is an inflammatory reaction of tissues in the elbow region. In an industrial environment, tennis elbow may follow effort requiring palm-upward hand motion against resistance, such as using a screwdriver, or the violent upward extension of the wrist with the palm down. The condition may be avoided by ensuring

that the rotation axis of the tool or machine coincides with the rotation axis of the forearm.

*Raynaud's Syndrome.* Raynaud's Syndrome occurs when blood vessels and nerves in the hands constrict from conditions such as cold temperature, vibration, or emotion. The hands, fingers, or finger tips may become cold, blue, numb, and lose fine manipulative ability. Upon recovery, the hands become red, accompanied by a burning sensation. It can be confused with the one-sided numbness of carpal tunnel syndrome.

## ***Corrective Actions***

Corrective actions to prevent CTDs include: adjusting the height of work tables, conveyors, and seats; automating tasks to eliminate manual handling; reducing the frequency of tasks or increasing the frequency to a point where automation is necessary; reducing the size or weight of loads; providing arm rests; redesigning hand tools so that the axis of rotation or application of force coincides with the axis of rotation of the arm; providing operator training; using careful preplacement screening to identify high risk employees; changing load positions in relation to the body or hands; minimizing the time that a load is held in the hands; eliminating gloves if they cause a problem or trying different gloves.

Among recommendations to help prevent the development of CTS (5) are these:

- Low frequency vibration in hand tools should be eliminated or reduced.
- Wrist deviation from the straight position should be minimized especially where a great deal of force must be exerted.
- Where possible, a closed fist (rather than a pinch) should be used to reduce tendon tension.

## ***Medical Treatment of Cumulative Trauma Disorders***

Correct diagnosis of a musculoskeletal injury is important to avoid the stressful activity that caused the injury, and to lead to effective treatment. Diagnosis includes identifying the affected part of the body, determining the extent of injury, and determining what caused the disorder. The patient's description will aid in determining what area is painful, how and when the pain started, and what tasks are difficult.

The physical examination consists of initial inspection for asymmetry or irregularities such as swelling cysts. Limitations in the patient's range of motion may indicate a joint, muscle, or tendon problem.

Once the disorder is located and the degree of damage is determined, proper treatment must be developed. Successful therapy may require weeks or months. During this time the patient's work activities may be restricted. An additional strategy could involve limiting movement of the injured area and possible splinting, the application of heat or cold, medication to reduce inflammation and swelling, and special exercise.

If conservative approaches fail, special drugs or surgery may be required. It is important that the worker not continue performing the same job or task that caused the injury. The worker could be reassigned, or the task should be redesigned.

## ***Hand Tools***

Each year, hand tools are the source of 7 to 8 percent of all compensable injuries (6). Improper use of hand tools and defective tools can cause biomechanical stress and injuries. Types of injuries frequently reported include broken bones, contusions, loss of eyes and eyesight, and puncture wounds. Additionally, fingers, tendons, and arteries are severed from the use of cutting tools.

Basic safety precautions mandate that tools always be kept in good condition and be used properly. Workers should be careful to use the proper tool for the job performed. Figure 5 illustrates particular hand tools with ergonomically designed features.

**Figure 5**

***Hand Tools with Ergonomic Features***

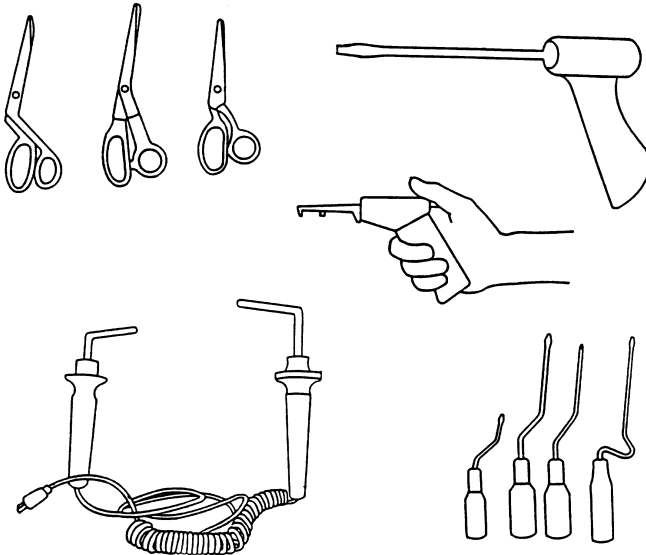

**Hand and Wrist Postures**

Some hand tools may force the wrist to assume awkward postures. The wrist position affects the effective strength of the contracting muscles. Therefore, as the angle of the joint increases or decreases from the neutral position, there is more stress on the tendons. Particularly stressful hand and arm positions are illustrated in figure 6. Ulnar deviation is the bending of the wrist toward the little finger, and radial deviation is the bending of the wrist toward the thumb. Extension is bending the wrist up and back, and flexion is bending of the wrist down towards the palm.

**Figure 6**

***Positions of the Hand and Arm***

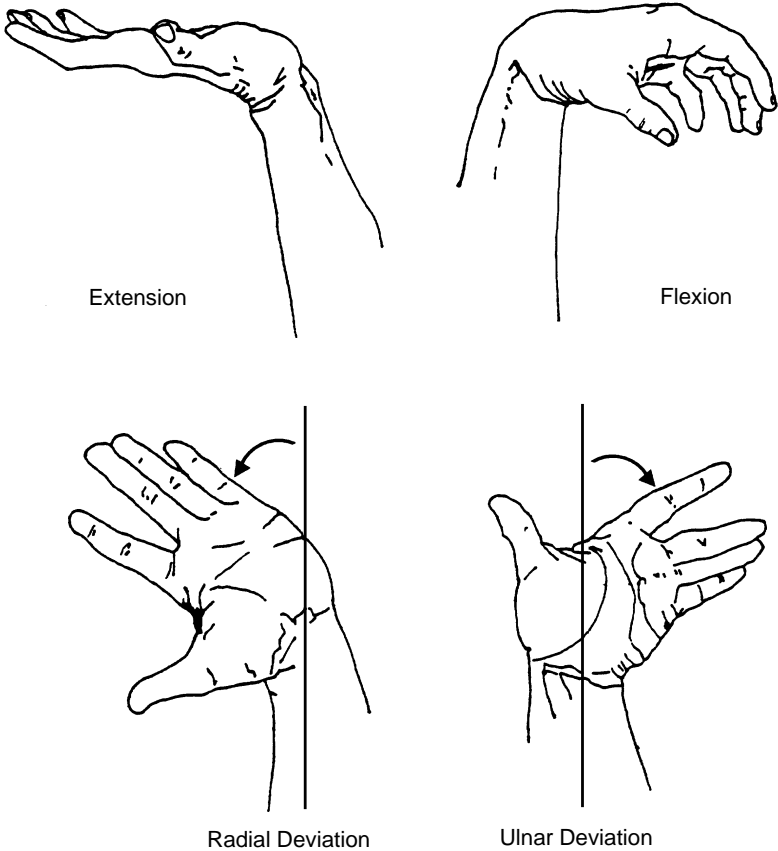

A job requiring repeated ulnar deviation, extension, or flexion can lead to tenosynovitis of the tendons on the back of the hand. Similarly, severe radial deviation can cause elbow soreness.

**Finger and Hand Grips**

The grips used most frequently to hold objects are shown in figure 7. The tip grip (pinching) is a position grasp used for precise manipulations. The side grip is

also classified as a precision grip. Repeated use of these grips creates stress on the two tendons controlling the thumbs and fingers. The power grip requires the thumb to align with the long axis of the forearm and the wrist assumes a slight ulnar deviation. The posture may be stressful when combined with high repetition and extreme force.

**Figure 7**

***Classifications of Grips***

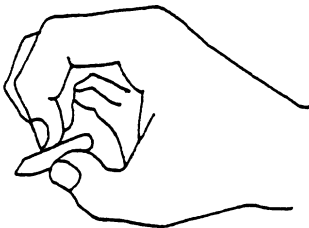

Tip

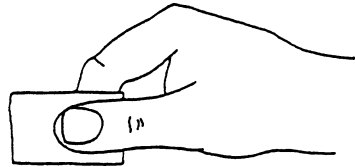

Side

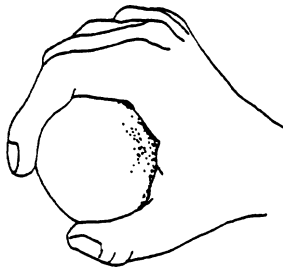

Power

# 5

## Seating

### ***Introduction***

Almost 50 percent of workers in the industrial world are thought to suffer from back problems. Many back problems originate from improper sitting positions. Complications that may arise from poor seating conditions include:

- Lumbar damage from lack of support in the lumbar region.
- Damage to the erector spinae muscles due to sitting without back support.
- Damage to the knees, legs, and lumbar region, from sitting without footrests of the proper height.
- Damage to various muscle groups (7).

### ***Proper Sitting Positions***

Proper sitting contributes to the physical well-being of a worker. It may also add as much as 40 minutes of production to each worker's day if the chair is properly selected and customized to support the lower back (8).

The ideal position for sitting at work exists when there is a slight curve in the lumbar region of the back, as is found in the standing position. The worker's shoulders should be relaxed, with the upper arms hanging down loosely. During work, the neck should not be bent too much.

### ***General Principles***

Rounding off the front of a chair avoids restriction of blood flow through the legs. The seat itself should be

reasonably flat in order to allow freedom of movement and to prevent hip-joint pressure. Padding on the seat minimizes pressure on the bones of the pelvis. Proper seat padding is an extremely important aspect of chair design, yet it is often ignored. A worker who often squirms in his or her seat may be sitting in a chair with improper seat padding. Padding that is too thick and soft can cause discomfort by immobilizing the legs. Chairs should be adjustable to five positions, have an arm rest adjustment, and have stability.

It is most important that the chair support the lumbar region of the back. Backrests should be used to maintain the normal back curvature. Backrests should be high enough to support the back but should not extend above the head and thereby restrict head, neck, and arm movement. Chair design should allow freedom of movement. Such freedom reduces fatigue, allows for a longer period of mental alertness, and allows an easier flow of body fluids.

### ***Guidelines to Chair Adjustment***

Workers should have adjustable chairs. The human body dimension that provides a starting point for determining correct chair height is the “popliteal” height. Figure 8 illustrates the popliteal height. This is the height from the floor to the point at the crease behind the knee. The chair height is correct when the entire sole of the foot can rest on the floor or footrest and the back of the knee is slightly higher than the seat of the chair. This allows the blood to circulate freely in the legs and feet. The back of the chair should be adjusted so that it catches the concave portion of the back’s lumbar region.



**Figure 8**  
***Popliteal Height***

Sagittal anthropometric measurements:  
1—internal sitting depth (buttock-popliteal)  
2—external sitting depth (buttock-patella)  
3—abdominal depth (buttock-abdomen)  
4—popliteal height

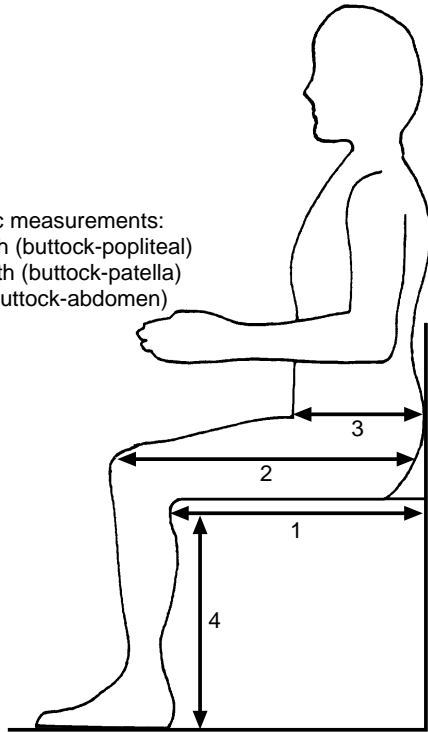

Simply because the seat has been adjusted does not mean a person has a proper arrangement for working. Kaplan (9) notes that the actual work surface should be adjusted. Work surfaces should be located so that the arms and shoulders do not have to be lifted to perform work. Additionally, the lower arm should form a slight upward angle or position.

Kaplan (10) also observes that once the seat and work surface are adjusted, the seat can be angled to tilt back, up to six degrees, depending on whether a person performs work forward, or at zero degrees, or between a back and forward position, alternatively. The purpose of

tilting the back angle is that leaning against the seat back relieves the force caused by the weight of the torso.

There must be a clearance between the back of the knees and the front of the seat. The clearance should exist for approximately four to five inches, measured from the leading edge of the chair. This clearance, combined with proper placement of the feet on the floor, support for the lumbar region without restricting movement unduly, and adjustment of the working height for the arms will eliminate most complaints and problems associated with seating.

### ***Sit-Stand Chair***

There is an alternative to standing or sitting for an entire work shift. The sit-stand chair allows the operator to alternate standing and sitting. Standing and sitting stress different muscles, so changing positions relaxes some muscles and stresses others. Operators may be able to stand or lean comfortably for long periods of time, while protecting the lower limbs and back from excessive strain. Sit-stands also allow a greater range of motion for workers who handle large objects.

### ***Balens Chair***

The Balens chair is an alternative to the traditional office chair. The Balens chair slopes forward so the operator can maintain a natural “S” curve in the back. As illustrated in figure 9, an operator sits on the upper cushion and kneels by placing his or her knees on the lower cushion. This position raises the pelvis and alleviates back discomfort. Weight is shifted from the lower back to an even distribution over the back and thighs. Sitting in a Balens chair for an extended period of time may cause knee or leg discomfort due to immobilization of the legs.

**Figure 9**  
***Balens Chair***

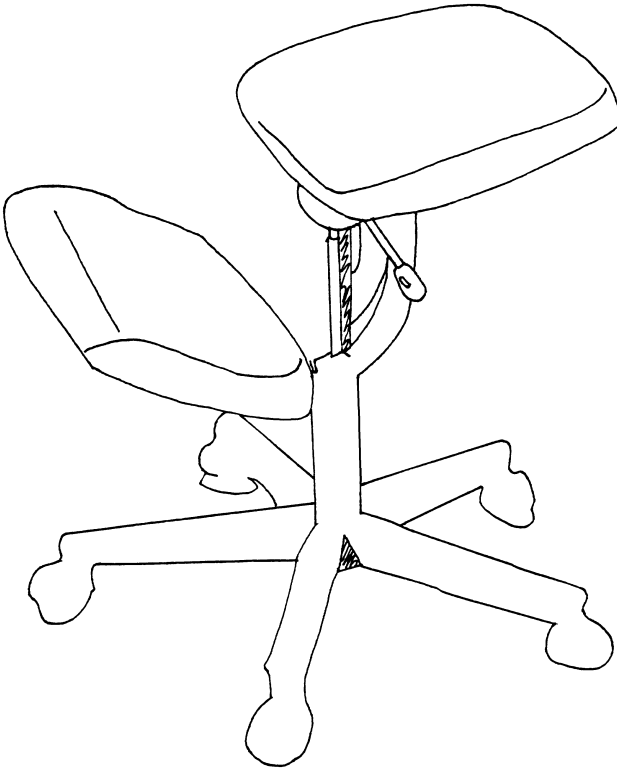

# 6

## Physical Space Arrangements

### *Introduction*

For workspace to be functional, both the user of the space and the work to be performed must be considered. Workspace arrangements should consider worker comfort, physical constraints, and performance requirements.

Four basic considerations regarding the worker which must be taken into account are:

- What the worker needs to see.
- The amount of communication needed with co-workers and supervisors.
- Equipment and material which the worker must be able to work with and reach.
- Body clearances which are needed by the worker.

Workstations should be set up with sound ergonomic principles in mind. For example, controls should be placed in a similar manner for similar types of equipment. Work loads should be distributed as evenly as possible between the feet and hands. To accommodate a broad variability in human beings, anthropometric data from the 5th to 95th percentile range should be used. An attempt should be made to anticipate all possible safety hazards, and emergency measures should be established prior to the occupancy of the workspace.

Visibility factors must be considered when workspace is designed. Clearance for a worker's body must also be considered. Additionally, the design of workspace is dependent upon the arrangement of task elements. Workspace can be designed to maximize worker performance and to minimize error. Equipment should be grouped and controls should be organized in such a way that a natural sequence of action can be followed.

It is important to consider both physiological and psychological elements in the design of a workspace. Space should be designed so that proper posture can be maintained, body weight can be properly distributed, cardiovascular action is properly maintained, and the possibility of fatigue is minimized.

A worker should receive psychological motivation from the workplace. To facilitate this, the workspace needs to be attractive, convenient, organized, safe, and simple.

Arm reach and hand motion are important considerations in workplace design. There are two types of arm reach: normal work area and maximum reach area. Normal work area is the portion of a workplace that can be reached by the hand without moving the arm from the side of the body. Maximum reach area is the portion of a workplace that can be reached by stretching the arms to full length without disturbing the position of the body. Ideally, a worker should be able to perform work at a station without moving beyond the normal work area or, occasionally, the maximum reach area.

Hand motions should be confined to the lowest of the following classification of movement: 1-fingers; 2-fingers and wrist; 3-fingers, wrist, and forearm; 4-fingers, wrist, forearm, and upper arm; 5-fingers, wrist, forearm, upper arm, and shoulder. To illustrate, motion in classification 1 is usually more desirable than that in classification 4, because there is less movement involved (11). Considerations regarding CTDs may require modification of these principles.

Environmental factors must be considered for workspace design. Lighting, noise, pressure, temperature, and vibration are some of the main considerations. For example, an arm support may reduce vibration effects, thereby improving the precision of manual control. Workspaces should be designed to eliminate or at least minimize negative effects of the environment upon work performance.

Workplace units are the parts which make up a particular workplace. These units include control/display panels, desks, seats, and other items. A control/display panel is made up of controls and displays defined by worker input and output requirements. It is important that these panels be properly positioned to guarantee that they can be properly used.

Considerations for establishing workplace units include visibility, the grouping of controls and displays in a functional manner, easy identification of displays/controls, clearances, and arranging panels in a logical sequence.

The priorities for determining workplace layout are:

- *First.* Primary visual tasks: position in relation to task sets the basic reference point for layout.
- *Second.* Ensure placement of primary controls which interact with the primary visual tasks.
- *Third.* Control/display relationships: displays should be in close proximity to the controls involved. For example, normally one would want to be able to perceive sound (the display) when an alarm (control) is activated. The control and display are in “close proximity.”
- *Fourth.* Workplace units should be arranged in the expected sequence of operation.
- *Fifth.* Workplace units should be placed according to the amount of use.
- *Sixth.* Layout within the same system should be consistent.

## ***Visual Considerations***

Control/display panels should be positioned around the worker’s natural line of vision. Visual displays should include warning lights, primary and secondary

displays, and auxiliary displays. Primary displays and emergency lights should be positioned so that excessive movement is not needed to view the panels. In general, displays should be located in the center, upper portion of the panel, and controls should be located in the lower area requiring limited arm extension.

### ***Work Area Design***

A workstation should be designed to accommodate the person who actually works on a given job. For example, workstations should not force workers into awkward body positions (see figure 10). Workstations should be easily adjustable and selected to fit specific tasks, so that they are comfortable for the workers using them. The workspace should be large enough to allow for the full range of required movements, especially where knives, saws, hooks, and similar tools are used.

**Figure 10**

#### ***Avoid Awkward Twisting***

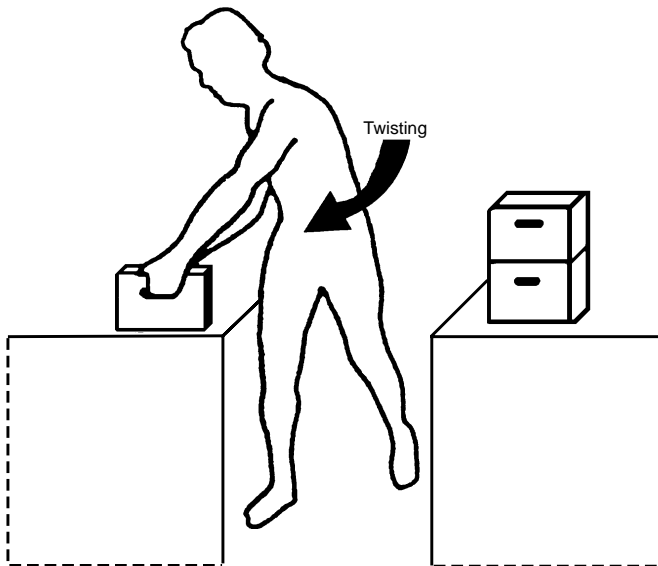

Methods for reducing extreme and awkward postures include:

- Adjustable fixtures and rotating tables so that the position of the work can be easily manipulated.
- Workstations and bins that can accommodate the heights and reach limitations of a wide range of workers.
- Work platforms that move up and down for certain operations.

Examples of methods to reduce the need to use excessive force include:

- Adjustable fixtures that allow operations and movements to be easily made.
- Properly located bins so that workers do not have to toss products and by-products.
- Mechanical or powered devices that eliminate the need for extreme manual force.
- The suspension of heavy tools.



# Minimization of Manual Materials Handling

## *Introduction*

Manual materials handling is another area in which injuries to employees can occur. This type of work entails lifting, bending, and twisting, which can cause great damage to the human body if done improperly. Figure 11 points out the region most frequently injured from manual lifting activities.

**Figure 11**

### *Area of Back Frequently Injured by Lifting Activities*

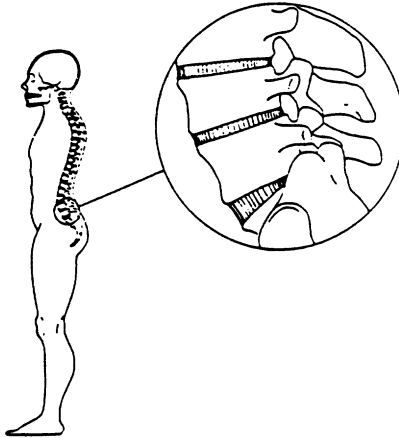

Lifting puts stress on two main body systems. One is the musculoskeletal system and the other is the cardiovascular system. Since the problem associated with the cardiovascular system deals with oxygen consumption or increased heart rate, the focus of most information regarding lifting has been the musculoskeletal system.

Most studies use criteria such as “stress in relation to capability over a given amount of time” as an index of the associated strain.

## ***Mechanical Aids***

One way to reduce manual materials handling problems is by using self-leveling dispensers, such as the spring-loaded tray dispensers used in many cafeterias. The way these mechanisms work is that when a load is removed, the platform rises in order to maintain the top layer at a constant level. A worker does not have to bend over or stretch upward to receive work. Instead, work can be reached at a constant height. These dispensers can eliminate unnecessary motion and thereby reduce worker fatigue.

Many other types of mechanical aids are available to assist employees during manual materials handling. Hooks, bars, rollers, jacks, platforms, and trestles (or A-frames) are examples of simple job aids. Drum handling units are in common use and exist as either a trestle or lever. In most cases, the engineer or ergonomist can find off-the-shelf aids readily available to fit the lifting task and to minimize the amount of manual lifting.

Other available equipment which will minimize, if not eliminate, manual materials handling includes the standard industrial equipment classes of conveyors, hoists and cranes, industrial vehicles (such as towmotor or forklift trucks), and positioners. Positioners are defined by the International Material Management Society as equipment used to transfer material from workplace to materials handling equipment, or vice versa. Positioners include manipulators, dumpers, up-enders, positioning tables, lifts, jacks, and transfer machines.

Today, with so much equipment available to the plant engineer or ergonomist, manual materials handling can be reduced, if not eliminated, for most tasks.

## ***Determining Lifting Limits***

This section outlines load limit recommendations in accordance with National Institute for Occupational Safety and Health criteria for manual lifting. It is intended to provide the industrial or safety engineer with an easy means to apply the data to appropriate lifting situations.

### **Definition of a Lifting Task**

For the purposes of this section, a lifting task is considered to be the act of manually grasping and raising an object of definable size without mechanical aids (such as hoists, conveyors, and block and tackle). The time duration of such an act is normally less than two seconds, thus, little sustained exertion is required (as contrasted with holding or carrying activities).

The lifting limits presented in this section do not apply to all kinds of lifts. They are intended to apply only for:

- Smooth lifting.
- Two-handed, symmetric lifting in the sagittal plane (directly in front of the body; no twisting during lift).
- Moderate width, for example, 30 inches (75 cm) or less.
- Unrestricted lifting posture.
- Good couplings (handles, shoes, floor surface).
- Favorable ambient environments.

It is assumed that other manual handling activities, such as holding, carrying, and pushing are minimal. When not engaged in lifting activities, the individual is assumed to be at rest. The worker is assumed to be fit and accustomed to physical labor.

The section does not include “safety factors” commonly used by engineers to assure that unpredicted conditions are accommodated.

## Lifting Task Variables

Primary lifting task variables, derived from epidemiology, biomechanics, physiology, and the psychophysics of lifting, include:

*Object weight (L)*—measured in pounds (or kilograms).

*Horizontal location (H)*—of the hands at origin of lift measured forward of the body centerline or midpoint between ankles in inches (or centimeters).

*Vertical location (V)*—of the hands at origin of lift measured from floor level in inches (or centimeters).

*Vertical travel distance (D)*—measured from origin to destination of lift in inches (or centimeters).

*Frequency of lifting (F)*—average number of lifts per minute.

*Duration or period*—assumed to be occasional (less than one hour) or continuous (eight hours).

Figure 12 illustrates some of these parameters.

Additional factors to be considered when evaluating lifting task variables are whether twisting is involved with the lifting, the type and quality of handtools used, and environmental factors (such as the weather and temperature). For a more detailed discussion of this topic, refer to *A Guide to Materials Handling and Back Safety* (IG #26).

Lifting may be classified into three general categories:

1. Infrequent—either occasional or continuous lifting of less than once per three minutes.
2. Occasional high frequency—lifting one or more times per three minutes for a period of up to one hour.
3. Continuous high frequency—lifting one or more times per three minutes continuously for eight hours.

**Figure 12**  
***Lifting Variables***

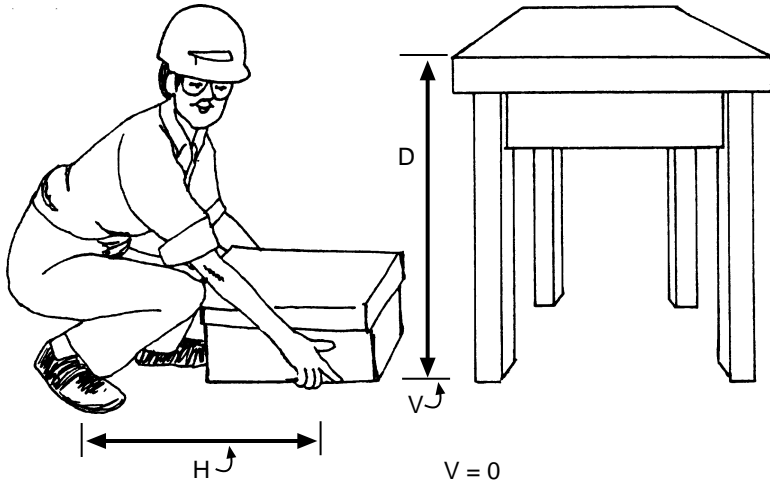

Scientific data show that for infrequent lifting, a person's musculoskeletal strength and potential high stress to the back are primary limitations to ability. As such, biomechanical variables are predominant in hazard determination. Occasional high frequency lifting results in psychophysical stress and possible muscle fatigue as the primary limitations. For continuous high frequency lifting, the primary limitations are based on cardiovascular capacity and metabolic endurance.

When the preceding lifting task variables are considered in relation to the approaches to classifying risks associated with lifting (epidemiological, biomechanical, physiological, and psychophysical), certain conclusions emerge. First, all of the task variables are highly interactive. For example, the importance of object weight is highly dependent on where the weight is located (horizontally and vertically) and on how far and how frequently the weight must be moved. Thus, none of these

variables should be evaluated independently. Second, the four approaches, taken separately, may lead to different conclusions. For example, metabolic criteria can lead one to believe that lifting heavy loads infrequently is preferred to the frequent lifting of lesser loads (due to the cost of moving the body). From a biomechanical or strength point of view, object weight should be minimized regardless of frequency.

Another example has to do with object location. A person generally produces the greatest lifting strength by use of the legs and back. Were strength the only criterion, one would favor leaving objects on the floor rather than on shelves. However, biomechanical low back compression, and cardiovascular criteria would deem that approach least desirable.

### **Criteria for a Guideline**

Regardless of the approach taken to evaluate lifting stress, keep in mind that there is a great risk variability when looking at any group of individuals. This requires that the resulting controls be both engineering and administrative in nature. In other words, there are some lifting situations which are so hazardous that only a few people could be expected to be capable of safely performing them. To reduce stresses, these situations need to be modified through job redesign.

Certain lifting conditions may be safely tolerated by some people whereas others, particularly weaker individuals, must be protected by an aggressive personnel selection and training program.

### ***The Effect of an Abdominal Belt***

Weightlifters and manual material handlers have perceived some benefit from wearing an abdominal belt. Most individuals state the purpose for wearing an abdominal (lifting) belt is that it may assist in generating intra-abdominal pressure without increasing

abdominal muscle activity. McGill, Norman, and Sharratt (12) conducted a study to determine whether abdominal belts, such as those recommended to workers involved in lifting tasks, reduced trunk muscle activity and/or increased intra-abdominal pressure. This study monitored six subjects lifting loads both with and without wearing a lifting belt, and lifting both with the breath held or continuously exhaling upon lifting. The results showed that with the breath held, erector spinae activity tended to be lower, suggesting a reduced load on the lumbar spine. However, wearing the belt did not facilitate this reduction. The authors concluded that “the muscle activity and intra-abdominal pressure results of this study make it difficult to justify the prescription of abdominal belts to workers.”

NIOSH and OSHA do not consider abdominal belts PPE and do not recommend them to prevent injury. Abdominal belts may provide the user with a false sense of protection to the back if improperly used or worn.

### ***Personal Lifting Monitors***

Another device used in industry to aid manual material handling is a personal lifting monitor. Unlike the abdominal belt, this device encourages safe lifting techniques by sounding an audible alarm when the wearer lifts incorrectly. When the wearer lifts properly by using correct body mechanics, the alarm stays silent. The device clips onto the wearer’s shirt pocket or the back of the employee’s shirt, depending on the manufacturer, and when the worker bends over at a specified angle, the alarm will sound. Another manufacturer of the monitors also incorporates a counter onto the device. This device counts automatically each time the alarm sounds. At the end of the day, the operator has a numerical count of incorrect lifts. Such a device can be effective because it reminds the wearer how important it is to lift properly.

Frequent “incorrect” lifting by employees may indicate a problem with workplace or job design. After identifying where back injuries are occurring (by the use of personal lifting monitors, through review of OSHA 200 logs, etc.), steps should be taken to identify ergonomic risk factors and deficiencies in the workplace that may lead or contribute to the problem. This can often be accomplished through the use of questionnaires, surveys, and audits, which are standard analytical tools of the occupational ergonomist.



# 8

## **Workers with Disabilities— Ergonomic Considerations**

### ***Introduction***

Approximately 43 million people in the United States are considered to have disabilities. Special design considerations are required to help them negotiate their daily activities.

The government and the business community have realized that, in the long run, it is cost effective to accommodate the special needs of these men and women. When the recipients of special design considerations are able to live useful and productive lives, everyone benefits.

### ***Americans with Disabilities Act of 1990***

The Americans with Disabilities Act of 1990 is a national mandate to eliminate discrimination against individuals with disabilities. Two key provisions of the act affect employers.

One section of the act prohibits discrimination regarding employment rights against qualified individuals with disabilities. For employers of 25 or more employees, that section became effective on July 26, 1992. Employers with 15 to 24 employees have been covered since July 26, 1994.

Generally, the act prohibits employment discrimination against persons with disabilities with regard to:

- *Pre-application.* For example, job descriptions may not limit jobs to individuals without disabilities.
- *Application.* To illustrate, the application form must be free of questions regarding medical history; and the location for completing the job application must be accessible to all.

- *Pre-employment.* As an example, if a medical examination is required after a job offer is made, it must be required of all, and there must be a mechanism to link the results of the examination to essential job functions.
- *Employment.* For instance, training and training facilities must accommodate individuals with disabilities.

Another section of the act requires that public accommodations, including commercial entities, be accessible to and usable by individuals with disabilities. Existing structures must (after January 26, 1992) either remove barriers to persons with disabilities or provide alternative services. Alterations to existing structures undertaken after January 26, 1992, must comply with accessibility guidelines issued by the U.S. Architectural and Transportation Barriers Compliance Board. Finally, new construction must now comply with the accessibility guidelines.

The list below includes some examples of facilities which would be accessible to and usable by individuals with disabilities. The list is provided to stimulate thinking about the needs of persons with disabilities.

- *Building Sites.* Accessible parking spaces should be reserved for those with disabilities. Curbs should not prohibit entry into buildings.
- *Walkways.* Walkways should be at least 48 inches wide and should have nonslip surfaces.
- *Entrances.* At least one entrance should be accessible to persons in wheelchairs. If elevators exist, at least one entrance should have a level that would allow wheelchairs to access an elevator.
- *Doors.* Doors should have a clear opening at least 32 inches wide. Doors should open by a single effort.

- *Stairs and Steps.* Stairs should have handrails at least 32 inches above step level. Steps should have risers of seven inches or less.
- *Floors.* Floors on each story should be at a common level or connected by a ramp.
- *Public Telephones.* Telephones should be equipped for persons with hearing disabilities (and so identified). The dial and coin slot should be 48 inches or less from the floor.
- *Elevators.* Elevators should be touch sensitive and floors should be announced by some kind of automated voice system. A person in a wheelchair facing the rear should be able to see the front of the elevator by a mirror (or floor identification should be at the rear).
- *Controls.* Light switches, temperature controls, fire alarms, and similar controls should be not more than 48 inches above the floor.
- *Restrooms.* There should be at least one toilet for each sex on each floor with facilities for the physically handicapped. Towel dispensers, disposal units, shelves, and mirrors no higher than 40 inches from the floor should be available.
- *Water Fountains.* Persons in wheelchairs should be able to use the water fountain. Fountains should be hand operated.
- *Hazards.* Lighting on ramps should be adequate. Exit signs should be easily identifiable to all persons with disabilities.

# 9

## Visual Display Terminals

### *Introduction*

Computers, word processors, and visual display terminals (VDTs) have revolutionized the office environment by reducing the tedium involved in retrieving documents and information. Such information is now available at the touch of the fingertip. Likewise, conventional typing and paper-stuffed filing cabinets may soon become obsolete.

A hidden toll is taken, however, on the employees who daily sit in front of their flickering display screens. They pay this price with sore necks and shoulders, cramped fingers, tired eyes, strained backs, numb buttocks, and aching legs and feet. Tension headaches are common. It may be possible to trace these ailments directly to improper workspace layout.

A standard visual display terminal is an electronic device that displays information on a screen and works on a principle similar to that of a television set. The picture tube is called a cathode ray tube (CRT). It contains a source of electrons which, when beamed across the phosphor-coated screen, produces a visible image. The operator manipulates the image through specific commands entered through a keyboard or a pointing device such as a mouse.

Because work involving sustained use of VDTs can be repetitious and confining, special attention must be paid to the user's comfort. Traditional ergonomic considerations include chair and table selection, rest breaks, office noise, light, and temperature. However, VDT use poses unique questions, such as:

- What type of screen image—character size, screen brightness—is optimal for the task?
- How can screen glare and reflections be eliminated?
- What type of keyboard is best for the user and the task?
- Where should the screen, document holder, and accessories be placed?

## ***Workstation Design***

Information in this section applies to visual workstations and is primarily based on American National Standards Institute (ANSI) guidelines. The purpose of ANSI guidelines is to set standards for the viewer, keyboard, work stand, footrests and other items, so that the physical environment suits the capabilities of the operator.

The equipment should be suited to the job. It should be set and spatially organized such that:

- Forced air exhausts are not directed toward the user.
- Workstation adjustment controls are convenient and easy to use.
- Equipment with the longest and/or most frequent eye contact lies in the center of the work field.
- Equipment handled the most lies within the optimal range of reach.
- Glare is avoided.
- Pronounced visual contrast differences between important subjects is avoided.

### **Visual Display Screens**

The primary viewing area should be between 0 and 60 degrees below the horizontal line of sight. The screen

should be tilted so that the middle of the screen is perpendicular to the viewing angle. The top row of data should not lie above eye level, and observation angles greater than 40 degrees should be avoided. To avoid distracting reflections, it may be necessary to tilt the screen or to use screen filters.

European standards recommend that the observation distance between the eye and cursor be between 17 and 24 inches, or 450 and 600 mm in an upright sitting position. ANSI recommends that the minimum viewing distance be 12 inches or 305 mm.

ANSI specifies several optical quality requirements. The contrast ratio between the characters and the background should be at least 3:1. Small characters must have a higher minimum contrast. "Jittering" displays should be eliminated. The discrete dots that make up the characters should not be perceptible. The characters must appear solid to the viewer.

Saturated blue on a dark background, thin lines, or high resolution information for text should be avoided. Pure red in displays should also be avoided to help colorblind people read displays.

### **Keyboards**

ANSI recommends that the keyboard permit the user to keep an angle between the upper arm and forearm at 70 to 90 degrees. The angle may increase if the operator is leaning back, but the maximum angle should not exceed 135 degrees. The keyboard should consist of the QWERTY layout, with "ASDFJKL;" as the home keys.

The keyboard should be stable for normal keying functions. A number keypad should be provided if the main task involves numerical data input from the keyboard. To reduce user discomfort, alternative keyboards may be needed, such as split-fixed or split and vertical inclined styles.

## **Document Holders; Footrests**

Document holders and footrests should be provided, if needed by individual operators. The document holder should be adjustable and extensible.

## **Work Surfaces**

The work surface should provide adequate leg room so that the legs are not cramped. The height of the leg clearance should be at least equivalent to the highest point on the thigh or knee. ANSI recommends that when the leg is perpendicular to the floor, minimum leg clearance depth under the work surface is 60 percent of the buttocks-to-knee length. The size of the work surface should also accommodate the task.

## **Work Chairs**

The height of a chair should allow the user to place the feet firmly on a support surface. The maximum seat depth should allow contact with the seat back at the lumbar region while allowing clearance behind the knees. Minimum seat width should be 18 inches or the thigh breadth of the seated user, whichever is greater.

If the chair design requires the user's feet to be flat on the floor, the seat pan angle should keep the angle between the upper and lower leg between 60 and 100 degrees. In addition, the angle between the seat pan and back should allow the user to maintain a working posture in which the torso-thigh angle is not less than 90 degrees (100 degrees is preferred).

Chairs should have back rests with lumbar support. If the chairs have arms, the distance between the armrests should be a minimum of 18.2 inches. Appropriate chair castors should be provided.

## **Noise and Temperature**

Noise should be reduced to a maximum of 55 decibels and sporadic noises above normal ambient sound levels

should be prevented. ANSI recommends that surface temperatures of equipment intended to be touched not exceed 95°F. Air drafts should not be allowed to flow under desks. Care should be taken to see that heat does not build up under desks as well.

### **Lighting**

ANSI recommends eliminating intense sources of light from the VDT user's peripheral field of vision. A nominal lighting strength of 300 to 500 lux is recommended whereby the intensity of lighting upon the work table at the display should never reach 300 lux. (Lux is the metric expression for illumination. One footcandle equals approximately ten lux.)

Work areas with nominal lighting intensity at 750 lux must be individually tested to determine whether the area is suited for display workstations. In rooms with nominal lighting intensity of 1000 lux or higher, there should not be any display workstations, unless special precautions are taken, such as using micro-mesh or glare filters (polarized and/or nonreflective coating should also be considered).

The American Telephone and Telegraph Company has proposed ways to reduce screen reflections. See table 1.

**Table 1**  
***Screen Reflection Reduction***

<b>Location</b>	<b>Measure</b>
At source	Cover windows. Place light fixtures properly. Use directional lighting.
At workstation	Move station. Tilt screen. Use screen filters or hoods. Use reverse video.
Between source and workstation	Hang or erect partitions.



## **VDT Workstation Accessories**

VDT workstation accessories are available to help provide a comfortable workstation and reduce fatigue. One accessory illustrated in figure 13 is a keyboard arm rest. Because typists frequently rest their wrists on the keyboard or tabletop while typing, excessive strain is placed on tendons controlling the fingers and hands. The wrist rest elevates and rests the wrists and reduces tendon stress. (The usual recommendation is to use the wrist rest during pauses in typing.)

The keyboard drawer illustrated in figure 13 slides under a desk when not in use, allowing efficient use of desk space. When the drawer is extended, the keyboard can be raised or lowered.

The extension arm illustrated in figure 13 allows the operator to place the monitor in a comfortable location for maximum efficiency. The extension arm rotates, extends, and retracts a swiveling monitor platform for viewer comfort and glare reduction.

**Figure 13**  
***VDT Workstation Accessories***



Arm Rest

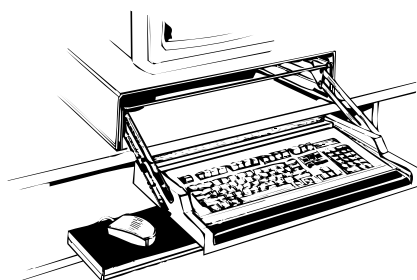

Keyboard Drawer

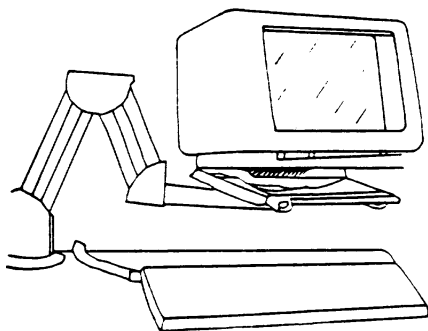

Extension Arm

## ***Summary***

The worker should plan to alternate VDT work with other tasks that do not require similar, close-work skills. Managers should be conscious of this work routine when planning a day's work schedule. Frequent breaks should be provided to allow the operator to stretch, move, and other non-hand intensive tasks. Recommended work/break intervals are: one break (5–10 minutes) for every hour of keying moderate work loads, with more frequent, short mini breaks or pauses (30–60 seconds) for more intense VDT use.

The key to a comfortable and productive office environment is recognition of each worker as an important individual with individual needs. Such recognition will increase morale and heighten productivity.

# Endnotes

1. International Occupational Safety and Health Information Centre. Ergonomics of machine guarding. December 1964. *CIS Information Sheet 10*. Geneva, Switzerland: International Labour Office. Page 2.
2. Shackel, B., ed. 1974. *Applied ergonomics handbook*. Surrey, England: IPC Business Press.
3. Ibid.
4. Cannon, L. J., E. J. Bernacki, and S. D. Walter. April 1981. Personal and occupational factors associated with carpal tunnel syndrome. *Journal of Occupational Medicine*. Vol. 23, No. 4:255–258.
5. Ibid.
6. National Safety Council. 1974. *Accident prevention manual for industrial operations*. 7th ed. Chicago: National Safety Council. Page 977.
7. Corlett, E. N., and I. Manencia. March 1980. The effects and measurement of working postures. *Applied Ergonomics*. Vol. 11, No. 1. Surrey, England: IPC Business Press.
8. Buell, N., et al. 1979. *Safety and health reference handbook*. Indianapolis: The Bosley Studios. Page 77.
9. Kaplan, A. June 1980. Sitting ergonomically. *Modern Office Procedures*. 140, 142, 144.
10. Kaplan, A. September 1981. Selecting a chair for the office. *Modern Office Procedures*. 130-131.
11. University of Texas at Austin. 1962. *Elements of work simplification*. Austin, Texas: The University of Texas at Austin, Continuing Education. Pages 101–102.
12. McGill, S. M., R. W. Norman, and M. T. Sharratt. 1990. The effect of an abdominal belt on trunk muscle activity and IAP during squat lifts. *Ergonomics*. Vol. 33, No. 2. London.

**The following industry guides are available from the N.C. Department of Labor's Division of Occupational Safety and Health:**

- #1. A Guide to Safety in Confined Spaces*
- #2. A Guide to Procedures of the Safety and Health Review Board of North Carolina*
- #3. A Guide to Machine Safeguarding*
- #4. A Guide to OSHA in North Carolina*
- #5. A Guide for Persons Employed in Cotton Dust Environments*
- #6. A Guide to Lead Exposure in the Construction Industry*
- #7. A Guide to Bloodborne Pathogens in the Workplace*
- #8. A Guide to Voluntary Training and Training Requirements in OSHA Standards*
- #9. A Guide to Ergonomics*
- #10. A Guide to Farm Safety and Health*
- #11. A Guide to Radio Frequency Hazards With Electric Detonators*
- #12. A Guide to Forklift Operator Training*
- #13. A Guide to the Safe Storage of Explosive Materials*
- #14. A Guide to the OSHA Excavations Standard*
- #15. A Guide to Developing and Maintaining an Effective Hearing Conservation Program*
- #17. A Guide to Asbestos for Industry*
- #18. A Guide to Electrical Safety*
- #19. A Guide to Occupational Exposure to Wood and Wood Dust*
- #20. A Guide to Crane Safety*
- #21. A Guide to School Safety and Health*
- #23. A Guide to Working With Electricity*
- #25. A Guide to Personal Protective Equipment*
- #26. A Guide to Manual Materials Handling and Back Safety*
- #27. A Guide to the Control of Hazardous Energy (Lockout/Tagout)*
- #28. A Guide to Eye Wash and Safety Shower Facilities*
- #29. A Guide to Safety and Health in Feed and Grain Mills*
- #30. A Guide to Working With Corrosive Substances*
- #31. A Guide to Formaldehyde*
- #32. A Guide to Fall Prevention in Industry*
- #33. A Guide to Office Safety and Health*
- #34. A Guide to Safety and Health in the Poultry Industry*
- #35. A Guide to Preventing Heat Stress*
- #36. A Guide to the Safe Use of Escalators and Elevators*
- #37. A Guide to Boilers and Pressure Vessels*
- #38. A Guide to Safe Scaffolding*
- #39. A Guide to Safety in the Textile Industry*
- #40. A Guide to Emergency Action Planning*
- #41. A Guide to OSHA for Small Businesses in North Carolina*

## Occupational Safety and Health (OSH) Sources of Information

**You may call 1-800-NC-LABOR to reach any division of the N.C. Department of Labor; or visit the NCDOL home page on the World Wide Web, Internet Web site address: <http://www.nclabor.com>.**

### **N.C. Division of Occupational Safety and Health**

Mailing Address:	Physical Location:
4 W. Edenton St.	111 Hillsborough St.
Raleigh, NC 27601-1092	(Old Revenue Building, 3rd Floor)
Local Telephone: (919) 807-2900	Fax: (919) 807-2856

*For information concerning education, training and interpretations of occupational safety and health standards contact:*

### **Bureau of Education, Training and Technical Assistance**

Mailing Address:	Physical Location:
4 W. Edenton St.	111 Hillsborough St.
Raleigh, NC 27601-1092	(Old Revenue Building, 4th Floor)
Telephone: (919) 807-2875	Fax: (919) 807-2876

*For information concerning occupational safety and health consultative services and safety awards programs contact:*

### **Bureau of Consultative Services**

Mailing Address:	Physical Location:
4 W. Edenton St.	111 Hillsborough St.
Raleigh, NC 27601-1092	(Old Revenue Building, 3rd Floor)
Telephone: (919) 807-2899	Fax: (919) 807-2902

*For information concerning migrant housing inspections and other related activities contact:*

### **Agricultural Safety and Health Bureau**

Mailing Address:	Physical Location:
4 W. Edenton St.	111 Hillsborough St.
Raleigh, NC 27601-1092	(Old Revenue Building, 2nd Floor)
Telephone: (919) 807-2923	Fax: (919) 807-2924

*For information concerning occupational safety and health compliance contact:*

### **Safety and Health Compliance District Offices**

#### **Raleigh District Office**

Telephone: Safety (919) 662-4597	Fax: (919) 662-4709
Health (919) 662-4711	

#### **Charlotte District Office**

(901 Blairhill Road, Suite 200, Charlotte, NC 28217-1578)  
Telephone: Safety (704) 342-6163 Fax: (704) 342-5919

#### **Winston-Salem District Office**

(901 Peters Creek Parkway, Winston-Salem, NC 27103-4551)  
Telephone: Safety (336) 761-2700 Fax: (336) 761-2326  
Health (336) 761-2700 Fax: (336) 761-2130

#### **Wilmington District Office**

(1200 N. 23rd St., Suite 205, Wilmington, NC 28405-1824)  
Telephone: (910) 251-2678 Fax: (910) 251-2654

#### **Asheville District Office**

(204 Charlotte Highway, Suite B, Asheville, NC 28803-8681)  
Telephone: (828) 299-8232 Fax: (828) 299-8266

**\*\*\*To make an OSHA Complaint, OSH Complaint Desk: (919) 807-2796\*\*\***

*For statistical information concerning program activities contact:*

### **Planning, Statistics and Information Management**

Mailing Address:	Physical Location:
4 W. Edenton St.	111 Hillsborough St.
Raleigh, NC 27601-1092	(Old Revenue Building, 2nd Floor)
Telephone: (919) 807-2950	Fax: (919) 807-2951

*For information about books, periodicals, vertical files, videos, films, audio/slide sets and computer databases contact:*

### **N.C. Department of Labor Library**

Mailing Address:	Physical Location:
4 W. Edenton St.	111 Hillsborough St.
Raleigh, NC 27601-1092	(Old Revenue Building, 5th Floor)
Telephone: (919) 807-2848	Fax: (919) 807-2849

### **N.C. Department of Labor (Other than OSH)**

4 W. Edenton St.  
Raleigh, NC 27601-1092  
Telephone: (919) 733-7166 Fax: (919) 733-6197