

# Selecting and Sizing an Industrial Control Transformer

## The importance of using an industrial control transformer

The use of an industrial control transformer is absolutely essential for the safe and reliable operation of control devices. Electromagnetic control components such as solenoids, contactors and timers place heavy demands on transformers powering them. These increased demands take place during start-up and the energizing of control sequences due to the inductive nature of most control devices. This results in very high inrush currents flowing through the transformer during start-up phases of control operation.

Dongan® industrial control transformers are specifically designed for use in control circuits characterized by high inrush VA loads. When properly selected and sized, these transformers can accommodate the severe demands placed on them while maintaining adequate voltage for control component operation.

Electromagnetic control component loads are

characterized by high amperage inrush currents when they are energized. This results in **inrush volt-ampere (inrush VA)** loads many times larger than nameplate VA being demanded of the transformer during start-up. Inrush VA loads can be 3 to 10 times ( in some case 20 times) higher than **sealed (steady state) VA** loads.

A general purpose transformer should not be used for control applications. They are not designed for high inrush loads. Their use could result in a serious lowering of secondary output voltage during the inrush period of 30 to 50 milliseconds. Reduced output voltage can prevent safe and normal component operation and may lead to premature failure of the transformer and connected control devices.

## Determining Selection Inrush VA

Transformer Selection Inrush VA refers to the effective load placed upon the industrial control transformer. Selection Inrush VA is calculated using both the sealed VA and the inrush VA. When Selection Inrush VA is calculated and known, the proper transformer VA can be obtained from the regulation and selection tables.

Selection Inrush VA is calculated by using total sealed VA and the total inrush VA. The total sealed VA is the VA the transformer must supply to the load for an extended length of time. It can be computed by adding up all the individual sealed VA of all devices in the control circuit. The inrush VA is usually available from the component manufacturer. In cases when it is not available, assume a 40% power factor to calculate from sealed VA. Total inrush VA is determined by adding up all the individual inrush VA loads of all components.

### Calculating selection inrush VA

**Method 1:** The most accurate formula for determining Selection Inrush VA is to calculate the total inrush VA vectorially:

**Selection Inrush VA =**

$$\sqrt{(VA \text{ sealed})^2 + (VA \text{ inrush})^2}$$

**Method 2:** While usually resulting in a slightly oversized transformer, a simpler method to determine Selection Inrush VA is to calculate it arithmetically:

**Selection Inrush VA =**

$$VA \text{ sealed} + VA \text{ inrush}$$



**Series 50**

Suffix Codes-052, -053, -054, -056, -058, -059, -134  
Pages 70 - 75



**Series HC**

Suffix Codes-41, -44, -46, -47  
Pages 76 - 79



**Series HC**

Suffix Codes-4100, -4400  
Page 77

# Selecting and Sizing an Industrial Control Transformer

## Selecting the correct VA capacity

Once Selection Inrush VA is calculated by one of the above methods, the selection charts below can be used. Calculated Selection Inrush VA from the chart. To assure adequate capacity, a power factor of 40% has been employed in the selection chart. To assure adequate capacity, power factors of both 40% and 20% have been employed.

### Selection Inrush VA Chart - Series 50

Series 50 Inrush VA		Selection Inrush Volt - Amperes at 85%, 90%, and 95% Of Rated Secondary Voltage					
		20% Power Factor			40% Power Factor		
kVA Cap.	Catalog Number	85% Sec Voltage	90% Sec Voltage	95% Sec Voltage	85% Sec Voltage	90% Sec Voltage	95% Sec Voltage
.050	50-0050-xxx	270	230	190	250	185	140
.075	50-0075-xxx	580	480	350	460	340	250
.100	50-0100-xxx	820	660	490	520	410	305
.150	50-0150-xxx	1350	1000	820	1250	900	640
.200	50-0200-xxx	1920	1380	840	1320	960	690
.250	50-0250-xxx	2780	1990	1190	1840	1290	790
.300	50-0300-xxx	3600	2680	1630	2470	1800	1070
.375	50-0375-xxx	4580	3300	2050	3100	2250	1300
.500	50-0500-xxx	6150	4450	2750	4350	3100	1900
.750	50-0750-xxx	10200	7300	4300	8450	5500	3700
1.0	50-1000-xxx	11800	8400	4600	8900	5900	3950
1.5	50-1500-xxx	22400	16300	9200	16500	12900	6900
2.0	50-2000-xxx	24600	16800	9800	19600	13300	7200
3.0	50-3000-xxx	32500	23600	13900	26500	19600	11700
5.0	50-5000-xxx	62000	46000	26800	49800	37200	29500

### Selection Inrush VA Chart - Series HC

Series HC Inrush VA		Selection Inrush Volt - Ampere at 85%, 90%, and 95% Of Rated Secondary Voltage					
		20% Power Factor			40% Power Factor		
kVA Cap.	Catalog Number	85% Sec Voltage	90% Sec Voltage	95% Sec Voltage	85% Sec Voltage	90% Sec Voltage	95% Sec Voltage
.050	HC-0050-xx	270	230	190	250	185	140
.075	HC-0075-xx	580	480	350	460	340	250
.100	HC-0100-xx	810	630	440	620	530	350
.150	HC-0150-xx	1350	1050	820	1250	900	640
.250	HC-0250-xx	2040	1610	1170	1940	1420	980
.375	HC-0375-xx	3240	2450	2030	2900	2050	1650
.500	HC-0500-xx	5600	4050	2900	4500	3500	2350
.750	HC-0750-xx	9300	6650	4800	7100	5650	3850
1.0	HC-1000-xx	14500	11000	7900	12600	9700	5800
1.5	HC-1500-xx	24200	18700	13500	19500	14100	9800
2.0	HC-2000-xx	37500	27500	19800	27500	20500	14000

The use of the 90% or 95% of rated secondary voltage column is recommended for transformer selection. The use of the 85% rated secondary voltage column does not provide adequate voltage output to accommodate existing below normal distribution voltages and voltage dips and during equipment and motor start-ups.

#### Example:

Sizing Data:

Sealed VA = 270 VA

Inrush VA = 1,728 VA

Using the formula in [Method 1](#):

**Selection Inrush VA**

$$= \sqrt{(VA \text{ sealed})^2 + (VA \text{ inrush})^2}$$

$$= \sqrt{(270)^2 + (1,728)^2}$$

**1749 VA**

In above example at 95% of rated secondary voltage and 40% (.4) P.F., the correct size is 500 VA.

Using the formula in [Method 2](#):

**Selection Inrush VA**

$$= VA \text{ sealed} + VA \text{ inrush}$$

$$= 270 + 1728$$

$$= 1998 VA$$

In above example at 95% of rated secondary voltage and 40% (.4) P.F., the correct size is 750 VA.

#### Conversion to kVA

The formula used to convert VA to kVA is listed below

$$kVA = \frac{VA \text{ (Volt amperes)}}{(1000)}$$

Typical VA requirements for 3 Pole, 60 Hz, 120 volt contactors are listed below

Manufacturer	Series	VA	NEMA Contactor Size							
			00	0	1	2	3	4	5	
Allen Bradley	500 Series	Inrush	—	192	192	240	660	1225	2040	1490
		Sealed	—	29	29	29	45	69	110	96
	K Series	Inrush	53	110	175	240	580	1000	1950	
		Sealed	15	20	22	31	43	65	98	
ABB	Heavy Duty Series	Inrush	85	85	100	150	490	900	1200	
	Sealed	9	9	12	15	35	55	65		
Cutler Hammer	A1 Series	Inrush	87	103	103	—	—	—	1158	
		Sealed	15	20	20	—	—	—	100	
	B1 Series	Inrush	102	103	103	140	390	1158	1158	
		Sealed	13	20	20	24	50	100	100	
Furnas (Siemens)	Inrush	218	218	218	218	310	957	1518		
	Sealed	25	25	25	25	26	75	116		
General Electric	Inrush	151	151	151	528	1152	1248	2580		
	Sealed	24	24	24	60	83	86	191		
Joslyn Clark	Inrush	210	210	210	210	724	880	1790		
	Sealed	18	18	18	18	30	39	295		
Siemens (Gould)	Inrush	76	76	76	194	365	530	1630		
	Sealed	12	12	12	21	35	40	110		
Square D	Inrush	165	245	245	311	700	1185	2970		
	Sealed	33	27	27	37	46	85	212		
Westinghouse	Inrush	160	160	160	160	625	625	1700		
	Sealed	25	25	25	25	50	50	180		

# IC - Century Series Industrial Control Transformers

## Features

- ◆ UL Listed, File E3210
- ◆ CUL Listed, File E3210
- ◆ CE to EN 61558 (with finger safe options installed)
- ◆ Voltage and fuse combinations suitable for global applications
- Epoxy encapsulated copper windings
- UL Class 105°C insulation system
- Cool operation with 55°C temperature rise
- All designs rated 50 / 60 Hertz
- DIN Rail mounting options 50 - 100 VA
- Combination screw heads for ease of installation
- IP 20 when finger safe terminal and/or fuse cover options are installed
- Meets or exceeds UL 5085, NEMA ST-1 and ANSI standards
- Jumper links provided

IC Series Voltage Combinations		
Suffix	Primary	Secondary
-102	120 x 240	24
-103	240 x 480	120, Triple Rated
-107	240 x 480	120/240, Triple Rated
-109	380/400/415	110/220
-122	120 x 240	24, w/Dual Primary Fuse Holders
-123	240 x 480	120 Triple Rated, w/Dual Primary Fuse Holders
-127	240 x 480	120/240, Triple Rated, w/Dual Primary Fuse Holders
-129	380/400/415	110/220, w/Dual Primary Fuse Holders
-132	120 x 240	24, w/Three Primary Fuse Holders
-133	240 x 480	120, Triple Rated, w/Three Primary Fuse Holders
-137	240 x 480	120/240, Triple Rated, w/Three Primary Fuse Holder
-139	380/400/415	110/220, w/Three Primary Fuse Holders

Consult the factory or your Dongan® Sales Representative for desired voltage combinations other than shown.



## Suffix -102

Primary 120 x 240 - Secondary 24									Primary Max Amps	Secondary Max Amps
VA Rating	Catalog Number	Weight lbs	Dimensions (Inches/mm)			Mounting Dimensions (Inches/mm)				
			Height A	Width B	Depth C	W1	W2	D	120/240 V	24 V
50	IC-0050-102	2.7	2.63/67	3.00/76	3.94/100	2.10/53.3	2.50/63.5	2.00/51	.42/.21	2.08
75	IC-0075-102	3.7	2.63/67	3.00/76	4.44/113	2.10/53.3	2.50/63.5	2.50/64	.63/.31	3.13
100	IC-0100-102	4.2	2.94/75	3.38/86	4.19/106	2.44/62	2.813/71.5	2.38/60	.83/.42	4.17
150	IC-0150-102	6.8	3.25/83	3.75/95	4.63/117	2.75/70	3.13/79	2.75/70	1.25/.63	6.25
250	IC-0250-102	9.2	3.88/98	4.50/114	4.44/113	3.56/90	3.94/100	2.75/70	2.08/1.04	10.42
350	IC-0350-102	12.5	3.88/98	4.50/114	5.44/138	3.56/90	3.94/100	3.75/95	2.92/1.46	14.58
500	IC-0500-102	18.2	4.50/114	5.25/133	5.44/138	4.00/101	4.38/111	3.63/92	4.17/2.08	20.83
750	IC-0750-102	22.2	5.00/127	5.25/133	6.94/176	4.00/101	4.38/111	5.25/133	6.25/3.13	31.25
1000	IC-1000-102	28.4	5.00/127	5.25/133	6.94/176	4.00/101	4.38/111	5.25/133	8.33/4.17	41.67

## Suffix -103

Primary 240 x 480, 230 x 460, 220 x 440 - Secondary 120, 115, 110, Triple Rated									Primary Max Amps	Secondary Max Amps
VA Rating	Catalog Number	Weight lbs	Dimensions (Inches/mm)			Mounting Dimensions (Inches/mm)				
			Height A	Width B	Depth C	W1	W2	D	240/480 V	120 V
50	IC-0050-103	2.7	2.63/67	3.00/76	3.94/100	2.10/53.3	2.50/63.5	2.00/51	.21/.10	.41
75	IC-0075-103	3.7	2.63/67	3.00/76	4.44/113	2.10/53.3	2.50/63.5	2.50/64	.31/.16	.62
100	IC-0100-103	4.2	2.94/75	3.38/86	4.19/106	2.44/62	2.813/71.5	2.38/60	.42/.21	.83
150	IC-0150-103	6.8	3.25/83	3.75/95	4.63/117	2.75/70	3.13/79	2.75/70	.63/.31	1.25
250	IC-0250-103	9.2	3.88/98	4.50/114	4.44/113	3.56/90	3.94/100	2.75/70	1.04/.52	2.08
350	IC-0350-103	12.5	3.88/98	4.50/114	5.44/138	3.56/90	3.94/100	3.75/95	1.46/.73	2.91
500	IC-0500-103	18.2	4.50/114	5.25/133	5.44/138	4.00/101	4.38/111	3.63/92	2.08/1.04	4.16
750	IC-0750-103	22.2	5.00/127	5.25/133	6.94/176	4.00/101	4.38/111	5.25/133	3.13/1.56	6.25
1000	IC-1000-103	28.4	5.00/127	5.25/133	6.94/176	4.00/101	4.38/111	5.25/133	4.17/2.08	8.33
1500	IC-1500-103	32	6.75/171	7.50/190	6.25/159	4.25/108	5.31/135	4.50/114	6.25/3.125	12.5
2000	IC-2000-103	38	6.75/172	7.50/191	7.25/184	4.25/109	5.31/135	5.50/140	8.3/4.16	16.7
3000	IC-3000-103	50	6.75/173	7.50/192	8.25/210	4.25/110	5.31/135	6.50/165	12.5/6.25	25



## Suffix -107

Primary 240 x 480, 230 x 460, 220 x 440 - Secondary 120/240, 115/230, 110/220 Triple Rated									Primary Max Amps	Secondary Max Amps
VA Rating	Catalog Number	Weight lbs	Dimensions (Inches/mm)			Mounting Dimensions (Inches/mm)				
			Height A	Width B	Depth C	W1	W2	D	240/480 V	120/240 V
50	IC-0050-107	2.7	2.63/67	3.00/76	3.94/100	2.10/53.3	2.50/63.5	2.00/51	.21/.10	.41/.21
75	IC-0075-107	3.7	2.63/67	3.00/76	4.44/113	2.10/53.3	2.50/63.5	2.50/64	.31/.16	.63/.31
100	IC-0100-107	4.2	2.94/75	3.38/86	4.19/106	2.44/62	2.813/71.5	2.38/60	.42/.21	.83/.42
150	IC-0150-107	6.8	3.25/83	3.75/95	4.63/117	2.75/70	3.13/79	2.75/70	.63/.31	1.25/.63
250	IC-0250-107	9.2	3.88/98	4.50/114	4.44/113	3.56/90	3.94/100	2.75/70	1.04/.52	2.08/1.04
350	IC-0350-107	12.5	3.88/98	4.50/114	5.44/138	3.56/90	3.94/100	3.75/95	1.46/.73	2.92/1.46
500	IC-0500-107	18.2	4.50/114	5.25/133	5.44/138	4.00/101	4.38/111	3.63/92	2.08/1.04	4.17/2.08
750	IC-0750-107	22.2	5.00/127	5.25/133	6.94/176	4.00/101	4.38/111	5.25/133	3.13/1.56	6.25/3.13
1000	IC-1000-107	28.4	5.00/127	5.25/133	6.94/176	4.00/101	4.38/111	5.25/133	4.17/2.08	8.33/4.17
1500	IC-1500-107	32	6.75/171	7.50/190	6.25/159	4.25/108	5.31/135	4.50/114	6.25/3.125	12.5/6.25
2000	IC-2000-107	38	6.75/172	7.50/191	7.25/184	4.25/109	5.31/135	5.50/140	8.3/4.16	16.7/8.3
3000	IC-3000-107	50	6.75/173	7.50/192	8.25/210	4.25/110	5.31/135	6.50/165	12.5/6.25	25/12.5

Dimensions and weights may change. Consult factory for Certified Drawings.

## Suffix -109

Primary 380/400/415 - Secondary 110/220									Primary Max Amps	Secondary Max Amps
VA Rating	Catalog Number	Weight lbs	Dimensions (Inches/mm)			Mounting Dimensions (Inches/mm)				
			Height A	Width B	Depth C	W1	W2	D	380/400/415 V	110/220 V
50	IC-0050-109	2.7	2.63/67	3.00/76	3.94/100	2.10/53.3	2.50/63.5	2.00/51	.13/.13/.12	.45/.23
75	IC-0075-109	3.7	2.63/67	3.00/76	4.44/113	2.10/53.3	2.50/63.5	2.50/64	.20/.19/.18	.68/.34
100	IC-0100-109	4.2	2.94/75	3.38/86	4.19/106	2.44/62	2.813/71.5	2.38/60	.26/.25/.24	.91/.45
150	IC-0150-109	6.8	3.25/83	3.75/95	4.63/117	2.75/70	3.13/79	2.75/70	.39/.38/.36	1.36/.68
250	IC-0250-109	9.2	3.88/98	4.50/114	4.44/113	3.56/90	3.94/100	2.75/70	.66/.63/.60	2.27/1.14
350	IC-0350-109	12.5	3.88/98	4.50/114	5.44/138	3.56/90	3.94/100	3.75/95	.92/.88/.84	3.18/1.59
500	IC-0500-109	18.2	4.50/114	5.25/133	5.44/138	4.00/101	4.38/111	3.63/92	1.32/1.25/1.20	4.55/2.27
750	IC-0750-109	22.2	5.00/127	5.25/133	6.94/176	4.00/101	4.38/111	5.25/133	1.97/1.88/1.81	6.82/3.41
1000	IC-1000-109	28.4	5.00/127	5.25/133	6.94/176	4.00/101	4.38/111	5.25/133	2.63/2.50/2.41	9.09/4.55
1500	IC-3000-109	32	6.75/171	7.50/190	6.25/159	4.25/108	5.31/135	4.50/114	3.95/3.75/3.61	13.6/6.81
2000	IC-3000-109	38	6.75/172	7.50/191	7.25/184	4.25/109	5.31/135	5.50/140	5.26/5/4.81	18.1/9.09
3000	IC-3000-109	50	6.75/173	7.50/192	8.25/210	4.25/110	5.31/135	6.50/165	7.89/7.50/7.22	27.3/13.6

## Suffix -122

Primary 120 x 240 - Secondary 24 Featuring Factory Installed Dual Primary Fuse Holders									Primary Max Amps	Secondary Max Amps
VA Rating	Catalog Number	Weight lbs	Dimensions (Inches/mm)			Mounting Dimensions (Inches/mm)				
			Height A	Width B	Depth C	W1	W2	D	120/240 V	24 V
50	IC-0050-122	2.7	4.88/124	3.00/76	3.94/100	2.10/53.3	2.50/63.5	2.00/51	.42/.21	2.08
75	IC-0075-122	3.7	4.88/124	3.00/76	4.44/113	2.10/53.3	2.50/63.5	2.50/64	.63/.31	3.13
100	IC-0100-122	4.2	5.19/132	3.38/86	4.19/106	2.44/62	2.813/71.5	2.38/60	.83/.42	4.17
150	IC-0150-122	6.8	5.50/140	3.75/95	4.63/117	2.75/70	3.13/79	2.75/70	1.25/.63	6.25
250	IC-0250-122	9.2	6.13/156	4.50/114	4.44/113	3.56/90	3.94/100	2.75/70	2.08/1.04	10.42
350	IC-0350-122	12.5	6.13/156	4.50/114	5.44/138	3.56/90	3.94/100	3.75/95	2.92/1.46	14.58
500	IC-0500-122	18.2	6.75/171	5.25/133	5.44/138	4.00/101	4.38/111	3.63/92	4.17/2.08	20.83
750	IC-0750-122	22.2	6.75/171	5.25/133	6.94/176	4.00/101	4.38/111	5.25/133	6.25/3.13	31.25
1000	IC-1000-122	28.4	6.75/171	5.25/133	6.94/176	4.00/101	4.38/111	5.25/133	8.33/4.17	41.67

\*Factory installed three pole fuse holders are available by ordering suffix -132. Note: The two primary fuse positions are rejection style (Class CC). Fuses are sold separately.

## Suffix -123

Primary 240 x 480, 230 x 460, 220 x 440 - Secondary 120, 115, 110, Triple Rated Featuring Factory Installed Dual Primary Fuse Holders									Primary Max Amps	Secondary Max Amps
VA Rating	Catalog Number	Weight lbs	Dimensions (Inches/mm)			Mounting Dimensions (Inches/mm)				
			Height A	Width B	Depth C	W1	W2	D	240/480 V	120 V
50	IC-0050-123	2.7	4.88/124	3.00/76	3.94/100	2.10/53.3	2.50/63.5	2.00/51	.21/.10	.41
75	IC-0075-123	3.7	4.88/124	3.00/76	4.44/113	2.10/53.3	2.50/63.5	2.50/64	.31/.16	.62
100	IC-0100-123	4.2	5.19/132	3.38/86	4.19/106	2.44/62	2.813/71.5	2.38/60	.42/.21	.83
150	IC-0150-123	6.8	5.50/140	3.75/95	4.63/117	2.75/70	3.13/79	2.75/70	.63/.31	1.25
250	IC-0250-123	9.2	6.13/156	4.50/114	4.44/113	3.56/90	3.94/100	2.75/70	1.04/.52	2.08
350	IC-0350-123	12.5	6.13/156	4.50/114	5.44/138	3.56/90	3.94/100	3.75/95	1.46/.73	2.91
500	IC-0500-123	18.2	6.75/171	5.25/133	5.44/138	4.00/101	4.38/111	3.63/92	2.08/1.04	4.16
750	IC-0750-123	22.2	6.75/171	5.25/133	6.94/176	4.00/101	4.38/111	5.25/133	3.13/1.56	6.25
1000	IC-1000-123	28.4	6.75/171	5.25/133	6.94/176	4.00/101	4.38/111	5.25/133	4.17/2.08	8.33
1500	IC-1500-123	32	8.25/209.6	7.50/190	6.25/159	4.25/108	5.31/135	4.50/114	6.25/3.12	12.5
2000	IC-2000-123	38	8.25/209.6	7.50/191	7.25/184	4.25/109	5.31/136	5.50/140	8.33/4.16	16.66
3000	IC-3000-123	50	8.25/209.6	7.50/192	8.25/210	4.25/110	5.31/137	6.50/165	12.5/6.25	25

\*Factory installed three pole fuse holders are available by ordering suffix -132. Note: The two primary fuse positions are rejection style (Class CC). Fuses are sold separately.

Dimensions and weights may change. Consult factory for Certified Drawings.

## Suffix -127

Primary 240 x 480, 230 x 460, 220 x 440 - Secondary 120/240, 115/230, 110/220 Triple Rated Featuring Factory Installed Dual Primary Fuse Holders									Primary Max Amps	Secondary Max Amps
VA Rating	Catalog Number	Weight lbs	Dimensions (Inches/mm)			Mounting Dimensions (Inches/mm)			240/480 V	120/240 V
			Height A	Width B	Depth C	W1	W2	D		
50	IC-0050-127	2.7	4.88/124	3.00/76	3.94/100	2.10/53.3	2.50/63.5	2.00/51	.21/.10	.41/.21
75	IC-0075-127	3.7	4.88/124	3.00/76	4.44/113	2.10/53.3	2.50/63.5	2.50/64	.31/.16	.63/.31
100	IC-0100-127	4.2	5.19/132	3.38/86	4.19/106	2.44/62	2.813/71.5	2.38/60	.42/.21	.83/.42
150	IC-0150-127	6.8	5.50/140	3.75/95	4.63/117	2.75/70	3.13/79	2.75/70	.63/.31	1.25/.63
250	IC-0250-127	9.2	6.13/156	4.50/114	4.44/113	3.56/90	3.94/100	2.75/70	1.04/.52	2.08/1.04
350	IC-0350-127	12.5	6.13/156	4.50/114	5.44/138	3.56/90	3.94/100	3.75/95	1.46/.73	2.92/1.46
500	IC-0500-127	18.2	6.75/171	5.25/133	5.44/138	4.00/101	4.38/111	3.63/92	2.08/1.04	4.17/2.08
750	IC-0750-127	22.2	6.75/171	5.25/133	6.94/176	4.00/101	4.38/111	5.25/133	3.13/1.56	6.25/3.13
1000	IC-1000-127	28.4	6.75/171	5.25/133	6.94/176	4.00/101	4.38/111	5.25/133	4.17/2.08	8.33/4.17
1500	IC-1500-123	32	8.25/209.6	7.50/190	6.25/159	4.25/108	5.31/135	4.50/114	6.25/3.12	12.5/6.25
2000	IC-2000-123	38	8.25/209.7	7.50/191	7.25/184	4.25/109	5.31/136	5.50/140	8.33/4.16	16.66/8.33
3000	IC-3000-123	50	8.25/209.8	7.50/192	8.25/210	4.25/110	5.31/137	6.50/165	12.5/6.25	25/12.5

\*Factory installed three pole fuse holders are available by ordering suffix -132. Note: The two primary fuse positions are rejection style (Class CC). Fuses are sold separately.

## Suffix -129

Primary 380/400/415 - Secondary 110/220 Featuring Factory Installed Dual Primary Fuse Holders									Primary Max Amps	Secondary Max Amps
VA Rating	Catalog Number	Weight lbs	Dimensions (Inches/mm)			Mounting Dimensions (Inches/mm)			380/400/415 V	110/220 V
			Height A	Width B	Depth C	W1	W2	D		
50	IC-0050-129	2.7	4.88/124	3.00/76	3.94/100	2.10/53.3	2.50/63.5	2.00/51	.13/.13/.12	.45/.23
75	IC-0075-129	3.7	4.88/124	3.00/76	4.44/113	2.10/53.3	2.50/63.5	2.50/64	.20/.19/.18	.68/.34
100	IC-0100-129	4.2	5.19/132	3.38/86	4.19/106	2.44/62	2.813/71.5	2.38/60	.26/.25/.24	.91/.45
150	IC-0150-129	6.8	5.50/140	3.75/95	4.63/117	2.75/70	3.13/79	2.75/70	.39/.38/.36	1.36/.68
250	IC-0250-129	9.2	6.13/156	4.50/114	4.44/113	3.56/90	3.94/100	2.75/70	.66/.63/.60	2.27/1.14
350	IC-0350-129	12.5	6.13/156	4.50/114	5.44/138	3.56/90	3.94/100	3.75/95	.92/.88/.84	3.18/1.59
500	IC-0500-129	18.2	6.75/171	5.25/133	5.44/138	4.00/101	4.38/111	3.63/92	1.32/1.25/1.20	4.55/2.27
750	IC-0750-129	22.2	6.75/171	5.25/133	6.94/176	4.00/101	4.38/111	5.25/133	1.97/1.88/1.81	6.82/3.41
1000	IC-1000-129	28.4	6.75/171	5.25/133	6.94/176	4.00/101	4.38/111	5.25/133	2.63/2.50/2.41	9.09/4.55

\*Factory installed three pole fuse holders are available by ordering suffix -132. Note: The two primary fuse positions are rejection style (Class CC). Fuses are sold separately.

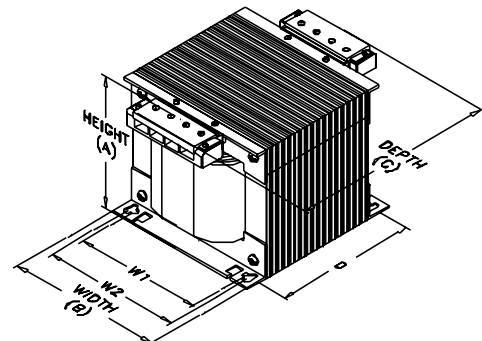

Dimensions and weights may change. Consult factory for Certified Drawings.

# IC Century Series

## Suffix -102 & -122

Primary			Secondary	
Voltage	Jumper	Connect Incoming Lines To	Voltage	Connect Load To
120	H1 to H3 & H2 to H4	H1 & H4	24	X1 & X2
240	H2 to H3	H1 & H4		

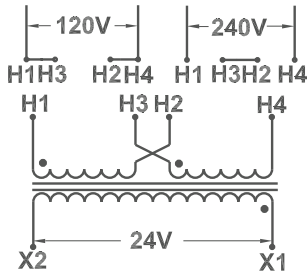

## Suffix -103 & -123

Primary			Secondary	
Voltage	Jumper	Connect Incoming Lines To	Voltage	Connect Load To
240 230 220	H1 to H3 & H2 to H4	H1 & H4	120 115 110	X1 & X2
480 460 440	H2 to H3	H1 & H4		

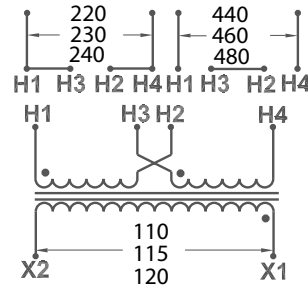

## Suffix -109 & -129

Primary			Secondary		
Voltage	Jumper	Connect Incoming Lines To	Voltage	Jumper	Connect Load To
380	-	H1 & H2		X1 to X3 & X2 to X4	X1 & X4
400	-	H1 & H3	110 220	X2 to X3	X1 & X4
415	-	H1 & H4			

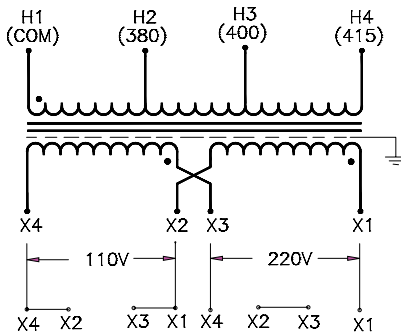

## Suffix -107 & -127

Primary			Secondary		
Voltage	Jumper	Connect Incoming Lines To	Voltage	Jumper	Connect Load To
240 230 220	H1 to H3 & H2 to H4	H1 & H4	120 115 110	X1 to X3 & X2 to X4	X1 & X4
480 460 440	H2 to H3	H1 & H4	120 115 110	X1 to X3 & X2 to X4	X1 & X4
240 230 220	H1 to H3 & H2 to H4	H1 & H4	240 230 220	X2 to X3	X1 & X4
480 460 440	H2 to H3	H1 & H4	240 230 220	X2 to X3	X1 & X4

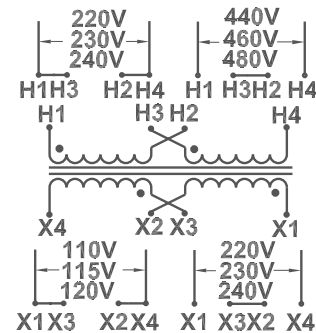



# Series IC - Accessory Installation Instructions

## Series IC Secondary Fuse Kit FCSEC 13/32" x 1 1/4" Fuses

	Max. Torque In-Lbs.	Wire Size Rating	Max. Fuse Rating
Terminal Screw	18	10 - 22 AWG	30 Amps @ 250 Volts

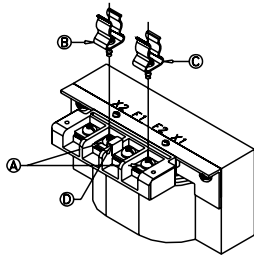

### Fusing X1 Side of Secondary

- Remove the screws from F1 & X1
- Install Jumper Link (D) along with the 2 Fuse Clips (B & C) using a 10-32 Screw provided.
- Connect one side of Jumper Link to F1 and the other to F2. Insure the fuse clip end stops are facing away from each other.
- Tighten screws to rated torque from chart above. Do not over-tighten.
- Connect the secondary load wires to F2 and X2.

### Fusing X2 Side of Secondary

- Remove the screws from F2 & X2
- Install Jumper Link (D) along with the 2 Fuse Clips (B & C) using a 10-32 Screw provided.
- Connect one side of Jumper Link to F2 and the other to F1. Insure the fuse clip end stops are facing away from each other.
- Tighten screws to rated torque from chart above. Do not over-tighten.
- Connect the secondary load wires to F1 and X1.

### FCSEC Fuse Kit Contents

- 2 Fuse Clips
- 2 #10-32 Screws
- 1 Jumper Link
- 1 Instruction Sheet

## Series IC Primary Fuse Kit FP2 Type CC Fuses

	Max. Torque In-Lbs.	Wire Size Rating	Max. Fuse Rating
Terminal Block	18	10 - 22 AWG	30 Amps @ 600 Volts
Fuse Block	20	10 - 22 AWG	

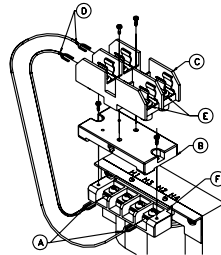

- Verify the primary jumpers are in the correct location for the desired input voltage.
- Connect one end of one of the Jumpers (A) to H1 and the other side to H4. (If using only fuse, connect one primary source wire to H4)
- Mount the Fuse Adapter Plate (B) to the Terminal Block using the 2 thread forming screws. The ridge on the bottom of the Fuse Adapter Plate must fit into the slot (F) of the Terminal Block.
- Mount the enclosed Fuse Block (C) to the Fuse Adapter Plate (B) using the 2 included machine screws.
- Connect the other side of the Jumpers (D) to the two Screw Terminals on the Fuse Block.
- Connect the primary source leads to the two Screw Terminals (E) on the Fuse Block.

### FP2 Fuse Kit Contents

- 1 Fuse Adapter Plate
- 1 Two pole 13/32 x 1 1/2 Class CC, Rejection type Fuse Block
- 2 Machine Screws
- 2 Thread Forming Screws
- 2 Jumper w/Ring Terminals
- 1 Instruction Sheet

## Series IC Primary Fuse Kit FP3 Type CC Fuses

	Max. Torque In-Lbs.	Wire Size Rating	Max. Fuse Rating
Terminal Block	18	10 - 22 AWG	30 Amps @ 600 Volts
Fuse Block	20	10 - 22 AWG	

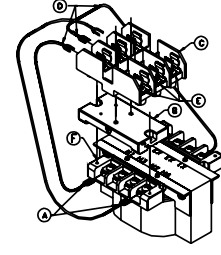

- Verify the primary jumpers are in the correct location for the desired input voltage.
- Connect one end of one of the Jumpers (A) to H1 and the other side to H4.
- Connect one side of the third lead wire to X1.
- Mount the Fuse Adapter Plate (B) to the Terminal Block using the 2 thread forming screws. The ridge on the bottom of the Fuse Adapter Plate must fit into the slot (F) of the Terminal Block.
- Mount the enclosed Fuse Block (C) to the Fuse Adapter Plate (B) using the 2 included machine screws.
- Connect the other side of the Jumpers (D) to the two Screw Terminals on the Fuse Block.
- Two will go to the primary fuse and one to the secondary fuse.
- Connect the primary source leads to the two Screw Terminals (E) on the Fuse Block.
- Connect one side of load to the secondary Fuse Block Terminal.

### FP3 Fuse Kit Contents

- 1 Fuse Adapter Plate
- 1 Three pole 13/32 x 1 1/2 Class CC, Rejection type Fuse Block
- 2 Machine Screws
- 2 Thread Forming Screws
- 3 Jumper w/Ring Terminals
- 1 Instruction Sheet

# Series IC - Accessory Installation Instructions

Series IC Secondary Fuse Kit FBSEC 1/4" x 1 1/4" Fuses			
	Max. Torque In-Lbs.	Wire Size Rating	Max. Fuse Rating
Terminal Block	18	10 - 22 AWG	30 Amps @ 300 Volts
Fuse Block	10	10 - 22 AWG	

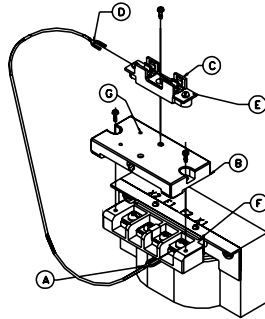

- Connect one side of the secondary load wire to X2
- Connect one secondary Jumper Wire (A) to X1
- Mount the Fuse Plate Adapter (B) to the terminal block using the 2 thread forming screws provided. The ridge on the bottom of the Fuse Plate Adapter Plate (B) must fit into the slot (F) of the Terminal Block.
- Mount the Fuse Block (C) to the Fuse Plate Adapter Plate (B) using one of the machine screws provided. Make sure the pin on the bottom of the Fuse Block is inserted into the hole (G) on the Fuse Plate Adapter (B).
- Connect the other side of the Jumper (D) to one side of the Fuse Block (C),
- Connect the other side of the secondary load wire to the open Fuse Block Terminal (E).

## FBSEC Fuse Kit Contents

- 1 Fuse Adapter Plate
- 1 1/4 x 1 1/4 Fuse Block
- 1 Machine Screw
- 2 Thread Forming Screws
- 1 Jumper w/Ring Terminal
- 1 Instruction Sheet

Series IC Primary Fuse Kit FPS3 2-Type CC Fuses & 1-FNM Fuse			
	Max. Torque In-Lbs.	Wire Size Rating	Max. Fuse Rating
Terminal Block	18	10 - 22 AWG	30 Amps @ 250 Volts
Fuse Block	20	10 - 22 AWG	

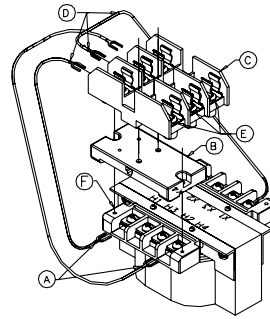

- Connect one side of the secondary load wire to X2
- Connect one secondary Jumper Wire (A) to X1
- Mount the Fuse Plate Adapter (B) to the terminal block using the 2 thread forming screws provided. The ridge on the bottom of the Fuse Plate Adapter Plate (B) must fit into the slot (F) of the Terminal Block.
- Mount the Fuse Block (C) to the Fuse Plate Adapter Plate (B) using one of the machine screws provided. Make sure the pin on the bottom of the Fuse Block is inserted into the hole (G) on the Fuse Plate Adapter (B).
- Connect the other side of the Jumper (D) to one side of the Fuse Block (C),
- Connect the other side of the secondary load wire to the open Fuse Block Terminal (E).

## FPS3 Fuse Kit Contents

- 1 Fuse Adapter Plate
- 1 Three Pole Fuse Block 13/32 x 1 1/2 Class CC, 2 Poles Rejection, 1 Pole Standard
- 1 Machine Screw
- 2 Thread Forming Screws
- 3 Jumpers w/Ring Terminals
- 1 Instruction Sheet

## Secondary Fuse Clips FCSEC

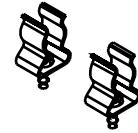

## Secondary Fuse Cover FSC

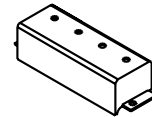

## Low Terminal Cover TC-1

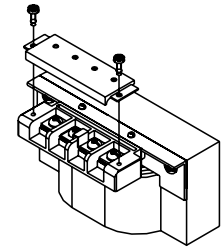

## PFC Primary Class CC Fuse Cover - PFC

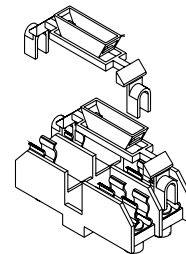

## Fuse Adapter Plate FA

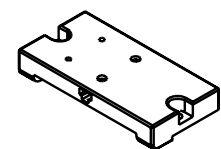

Features



- All Copper Windings
- IEC type finger safe terminals
- 200°C Insulation Systems
- 50/60 Hz
- Class 1, General Use, Isolating Transformer
- Electrostatic Shield, (earth metal screen)
- Regulation equals or exceeds industry standards
- Color coded protective earth (PE) terminal
- Nonstandard designs are available by consulting the factory or your Dongan® Representative

ES Series Voltage Combinations		
Suffix	Primary	Secondary
.326	380/400/416/440/460/480/575	110/115/120
.366	380/416/480	120/24 (24 Volt load is limited to 20% of rated kVA maximum)
.376	380/400/416	110/220 115/230 120/240
.386	220/380/400/416	95/115/120

VA	Catalog Number	Catalog Number	Catalog Number	Catalog Number	Dimensions (Inches/mm)			Mounting Dimensions (Inches/mm)			Weight
					Height A	Width B	Depth C	D	E	F	
150	ES-10100.326	ES-10100.366	ES-10100.376	ES-10100.386	5.31/135	4.50/114	4.00/102	2.75/70	3.75/95	.203x.375 (5.2 x 9.5)	8
250	ES-10130.326	ES-10130.366	ES-10130.376	ES-10130.386	6.31/160	4.50/114	5.25/133	3.25/83	3.75/95	.312 x .625(7.9 x 15.9)	10
375	ES-10150.326	ES-10150.366	ES-10150.376	ES-10150.386	6.31/160	4.50/114	6.00/152	4.50/114	3.75/95	.312 x .625(7.9 x 15.9)	13
500	ES-10170.326	ES-10170.366	ES-10170.376	ES-10170.386	6.88/175	5.25/133	5.25/133	3.25/83	4.38/111	.312 x .625(7.9 x 15.9)	15
750	ES-10190.326	ES-10190.366	ES-10190.376	ES-10190.386	7.81/198	6.38/162	6.00/152	4.00/102	5.31/135	.312 x .625(7.9 x 15.9)	26
1000	ES-10200.326	ES-10200.366	ES-10200.376	ES-10200.386	7.81/198	6.38/162	6.50/165	4.50/114	5.31/135	.312 x .625(7.9 x 15.9)	30
1500	ES-10210.326	ES-10210.366	ES-10210.376	ES-10210.386	8.81/224	7.50/191	6.00/152	4.00/102	6.00/152	.312 x .625(7.9 x 15.9)	36
2000	ES-10230.326	ES-10230.366	ES-10230.376	ES-10230.386	8.81/224	7.50/191	7.00/178	5.00/127	6.00/152	.312 x .625(7.9 x 15.9)	50
3000	ES-10250.326		ES-10250.376	ES-10250.386	8.88/226	7.50/191	8.00/203	6.00/152	6.00/152	.312 x .625(7.9 x 15.9)	60
5000	ES-10300.326		ES-10300.376	ES-10300.386	10.31/262	9.00/229	9.00/229	6.50/165	6.50/165	.312 x .625(7.9 x 15.9)	90

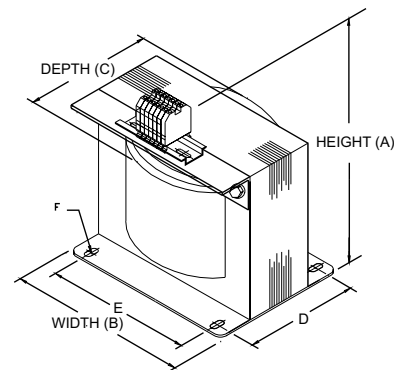

Series ES  
Style of terminals may vary depending on availability.

A Certificate of Compliance is available by contacting your Dongan® Representative or the factory Customer Service Department.

Dimensions and weights may change. Consult factory for Certified Drawings.

Suffix - .366			
Primary		Secondary	
Voltage	Connect Incoming Lines To	Secondary Voltage	Connect Load To
380	H1 & H3	24*	X1 & X3
416	H1 & H4	120	X1 & X4
480	H1 & H5		

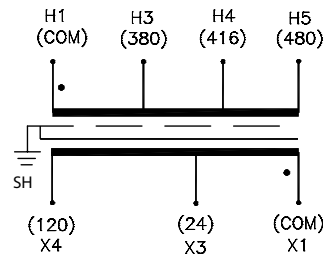

\*Maximum permissible load on the 24 volt secondary is limited to 20% of the transformer's kVA. When 24 and 120 volts are used simultaneously, the total of both loads must not exceed the total transformer kVA.

Suffix - .326			
Primary		Secondary	
Voltage	Connect Incoming Lines To	Secondary Voltage	Connect Load To
380	H1 & H3	110	X1 & X3
400	H1 & H3	115	X1 & X3
416	H1 & H4	115	X1 & X4
440	H1 & H4	120	X1 & X4
460	H1 & H4	115	X1 & X3
480	H1 & H4	120	X1 & X3
575	H1 & H5	120	X1 & X4

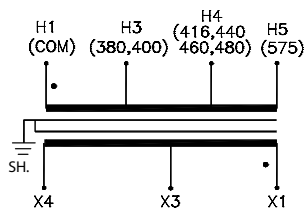

Suffix - .376				
Primary		Secondary		
Voltage	Connect Incoming Lines To	Secondary Voltage	Interconnect	Connect Load To
380	H1 & H2	110	X1 to X3 & X2 to X4	X1 & X4
400	H1 & H2	115		X1 & X4
416	H1 & H2	120		X1 & X4
380	H1 & H2	220		X1 & X4
400	H1 & H2	230	X2 to X3	X1 & X4
416	H1 & H2	240		X1 & X4
416	H1 & H2	120/240	X2 to X3	X1 & X2/X3 & X4

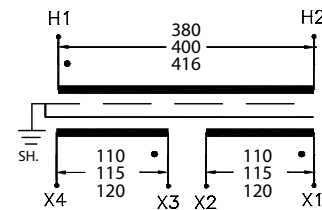

Suffix - .386			
Primary		Secondary	
Voltage	Connect Incoming Lines To	Secondary Voltage	Connect Load To
220	H1 & H3	95	X1 & X3
380	H1 & H4	115	X1 & X4
400	H1 & H5	120	X1 & X5
416	H1 & H6		

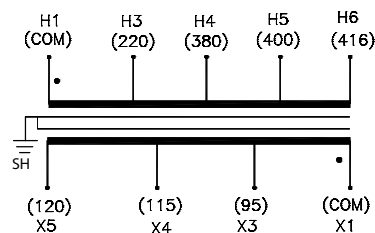



## Features



- All Copper Windings
- Core mounted, barrier type terminal panels
- Series/parallel jumper clips provided
- Secondary fuse kits (FKS) furnished
- Easy installation of available primary fuse kit (FK2P)
- Regulation equals or exceeds industry standards
- UL Class 180°C insulation system, 55°C temperature rise through 150 VA
- UL Class 180°C insulation system, 115°C temperature rise 250 VA and above
- All designs rated 50 / 60 Hertz up to 750 VA, 60 Hertz 1000 VA and above
- Primary fuse blocks and secondary fuse holders available
- Combination screw heads for ease of installation
- Meets or exceeds UL 506, NEMA ST-1 and ANSI standards
- Nonstandard designs are available by consulting the factory or your Dongan® Representative

### HC Series Voltage Combinations

Suffix	Primary	Secondary
-41	240 x 480	120 Triple Rated
-4100	240 x 480	120 Triple Rated w/ Fuse Blocks Installed
-44	208/240/480	120
-4400	208/240/480	120 w/ Fuse Blocks Installed
-46	600/575/550	120/115/110
-47	240/480/600	120/115/110

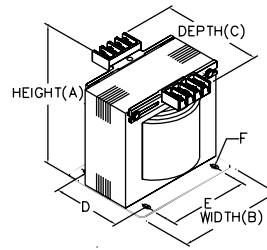

Outline Drawing  
HC Suffix -41, -44, -46, -47

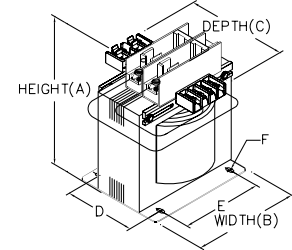

Outline Drawing  
HC Suffix -4100, -4400

## Suffix -41

Primary 240 x 480, 230 x 460, 220 x 440 - Secondary 120, 115, 110 - Triple Rated									Primary Max Amps	Secondary Max Amps
VA	Catalog Number	Weight	Dimensions (Inches/mm)			Mounting Dimensions (Inches/mm)			240/480 V	120 V
			Height A	Width B	Depth C	D	E	F		
50	HC-0050-41	3	3.25/83	3.00/76	4.75/121	2.00/51	2.50/64	.203x.375 (5.2 x 9.5)	.21/.10	.42
75	HC-0075-41	4	3.25/83	3.00/76	5.25/133	2.50/64	2.50/64	.203x.375 (5.2 x 9.5)	.31/.16	.63
100	HC-0100-41	5	3.25/83	3.00/76	5.62/143	2.87/73	2.50/64	.203x.375 (5.2 x 9.5)	.42/.21	.83
150	HC-0150-41	7	3.75/95	3.75/95	5.25/133	2.62/67	3.13/80	.203x.375 (5.2 x 9.5)	.63/.31	1.25
250	HC-0250-41	8.5	3.75/95	3.75/95	5.62/143	2.87/73	3.13/80	.203x.375 (5.2 x 9.5)	1.04/.52	2.08
300	HC-0300-41	9.5	3.75/95	3.75/95	6.00/152	3.25/83	3.13/80	.203x.375 (5.2 x 9.5)	1.25/.63	2.50
375	HC-0375-41	10	4.25/108	4.50/114	5.50/140	2.75/70	3.75/95	.203x.375 (5.2 x 9.5)	1.56/.78	3.13
500	HC-0500-41	11.5	4.25/108	4.50/114	6.00/142	3.25/83	3.75/95	.203x.375 (5.2 x 9.5)	2.08/1.04	4.17
750	HC-0750-41	15.5	4.25/108	4.50/114	6.87/175	4.12/105	3.75/95	.203x.375 (5.2 x 9.5)	3.12/1.56	6.25
1000	HC-1000-41	19	4.87/124	5.25/133	6.50/165	3.87/98	4.37/111	.281x562 (7.1 x 14.3)	4.16/2.08	8.33
1500	HC-1500-41	27	4.87/124	5.25/133	7.87/200	5.12/130	4.37/111	.281x562 (7.1 x 14.3)	6.25/3.12	12.50
2000	HC-2000-41	32	4.87/124	5.25/133	9.12/232	6.40/163	4.37/111	.281x562 (7.1 x 14.3)	8.33/4.16	16.67

## Suffix -44

Primary 208 / 240 / 480 - Secondary 120									Primary Max Amps	Secondary Max Amps
VA	Catalog Number	Weight	Dimensions (Inches/mm)			Mounting Dimensions (Inches/mm)			208/240/480 V	120 V
			Height A	Width B	Depth C	D	E	F		
50	HC-0050-44	3	3.25/83	3.00/76	5.00/127	2.25/57	2.50/64	.203x.375 (5.2 x 9.5)	.24/.21/.10	.42
75	HC-0075-44	4	3.25/83	3.00/76	5.62/143	2.87/73	2.50/64	.203x.375 (5.2 x 9.5)	.36/.31/.16	.63
100	HC-0100-44	5.5	3.75/95	3.75/95	5.25/133	2.50/64	3.13/80	.203x.375 (5.2 x 9.5)	.48/.42/.21	.83
150	HC-0150-44	7.5	3.75/95	3.75/95	6.12/155	3.31/84	3.13/80	.203x.375 (5.2 x 9.5)	.72/.63/.31	1.25
250	HC-0250-44	8.5	4.30/109	4.50/114	5.25/133	2.50/64	3.75/95	.203x.375 (5.2 x 9.5)	1.21/1.04/.52	2.08
300	HC-0300-44	10.5	4.30/109	4.50/114	6.00/152	3.25/83	3.75/95	.203x.375 (5.2 x 9.5)	1.4/1.25/.63	2.50
375	HC-0375-44	11.5	4.30/109	4.50/114	6.00/152	3.25/83	3.75/95	.203x.375 (5.2 x 9.5)	1.8/1.56/.78	3.13
500	HC-0500-44	13.5	4.30/109	4.50/114	6.50/165	3.75/95	3.75/95	.203x.375 (5.2 x 9.5)	2.4/2.08/1.04	4.17
750	HC-0750-44	18.5	4.87/124	5.25/133	6.50/165	3.75/95	4.37/111	.203x.375 (5.2 x 9.5)	3.6/3.12/1.56	6.25
1000	HC-1000-44	20	4.87/124	5.25/133	6.75/171	4.00/102	4.37/111	.281x562 (7.1 x 14.3)	4.8/4.16/2.08	8.33
1500	HC-1500-44	29.5	4.87/124	5.25/133	8.50/216	5.87/149	4.37/111	.281x562 (7.1 x 14.3)	7.2/6.25/3.12	12.50
2000	HC-2000-44	32	6.25/159	4.25/108	8.50/216	5.93/151	3.43/87	.281x562 (7.1 x 14.3)	9.6/8.33/4.16	16.67



## Suffix -46

Primary 600/575/550 - Secondary 120, 115, 110 - Triple Rated									Primary Max Amps	Secondary Max Amps
VA	Catalog Number	Weight lbs	Dimensions (Inches/mm)			Mounting Dimensions (Inches/mm)				
			Height A	Width B	Depth C	D	E	F	600 V	120 V
50	HC-0050-46	3	3.25/83	3.00/76	4.75/121	2.00/51	2.50/64	.203x.375 (5.2 x 9.5)	.08	.42
75	HC-0075-46	4	3.25/83	3.00/76	5.25/133	2.50/64	2.50/64	.203x.375 (5.2 x 9.5)	.13	.63
100	HC-0100-46	5	3.25/83	3.00/76	5.62/143	2.87/73	2.50/64	.203x.375 (5.2 x 9.5)	.17	.83
150	HC-0150-46	7	3.75/95	3.75/95	5.25/133	2.62/67	3.13/80	.203x.375 (5.2 x 9.5)	.25	1.25
250	HC-0250-46	8.5	3.75/95	3.75/95	5.62/143	2.87/73	3.13/80	.203x.375 (5.2 x 9.5)	.42	2.08
300	HC-0300-	9.5	3.75/95	3.75/95	6.00/142	3.25/83	3.13/80	.203x.375 (5.2 x 9.5)	.50	2.50
375	HC-0375-46	10	4.2/107	4.50/114	5.30/135	2.75/70	3.75/95	.203x.375 (5.2 x 9.5)	.63	3.13
500	HC-0500-46	11.5	4.25/108	4.50/114	6.00/142	3.25/83	3.75/95	.203x.375 (5.2 x 9.5)	.83	4.17
750	HC-0750-46	15.5	4.25/108	4.50/114	6.87/175	4.12/105	3.75/95	.203x.375 (5.2 x 9.5)	1.3	6.25
1000	HC-1000-46	19	4.87/124	5.25/133	6.50/165	3.87/98	4.37/111	.281x562 (7.1 x 14.3)	1.7	8.33
1500	HC-1500-46	27	4.87/124	5.25/133	7.87/200	5.12/130	4.37/111	.281x562 (7.1 x 14.3)	2.5	12.50
2000	HC-2000-46	32	4.87/124	5.25/133	9.12/232	6.40/163	4.37/111	.281x562 (7.1 x 14.3)	3.3	16.67

## Suffix -47

Primary 240/480/600, 230/460/575, 220/440/550 - Secondary 120/115/110 Triple Rated									Primary Max Amps	Secondary Max Amps
VA	Catalog Number	Weight lbs	Dimensions (Inches/mm)			Mounting Dimensions (Inches/mm)				
			Height A	Width B	Depth C	D	E	F	208/240/480 V	120 V
50	HC-0050-47	3	3.25/83	3.00/76	5.00/127	2.25/57	2.50/64	.203x.375 (5.2 x 9.5)	.21/.10/.08	.42
75	HC-0075-47	4	3.25/83	3.00/76	5.62/143	2.87/73	2.50/64	.203x.375 (5.2 x 9.5)	.31/.16/.13	.63
100	HC-0100-47	5.5	3.75/95	3.75/95	5.25/133	2.50/64	3.13/80	.203x.375 (5.2 x 9.5)	.42/.21/.17	.83
150	HC-0150-47	7.5	3.75/95	3.75/95	6.12/155	3.31/84	3.13/80	.203x.375 (5.2 x 9.5)	.63/.31/.25	1.25
250	HC-0250-47	8.5	4.30/1.09	4.50/114	5.25/133	2.50/64	3.75/95	.203x.375 (5.2 x 9.5)	1.04/.52/.42	2.08
300	HC-0300-47	10.5	4.30/1.09	4.50/114	6.00/152	3.25/83	3.75/95	.203x.375 (5.2 x 9.5)	1.25/.63/.50	2.50
375	HC-0375-47	11.5	4.30/1.09	4.50/114	6.00/152	3.25/83	3.75/95	.203x.375 (5.2 x 9.5)	1.56/.78/.63	3.13
500	HC-0500-47	13.5	4.30/1.09	4.50/114	6.50/165	3.75/95	3.75/95	.203x.375 (5.2 x 9.5)	2.08/1.04/.83	4.17
750	HC-0750-47	18.5	4.87/124	5.25/133	6.50/165	3.75/95	4.37/111	.203x.375 (5.2 x 9.5)	3.1/1.6/1.3	6.25
1000	HC-1000-47	20	4.87/124	5.25/133	6.75/171	4.00/102	4.37/111	.281x562 (7.1 x 14.3)	4.16/2.08/1.7	8.33
1500	HC-1500-47	29.5	4.87/124	5.25/133	8.50/216	5.87/149	4.37/111	.281x562 (7.1 x 14.3)	6.25/3.12/2.5	12.50
2000	HC-2000-47	32	6.25/159	4.25/108	8.50/216	5.93/151	3.43/87	.281x562 (7.1 x 14.3)	8.33/4.16/3.3	16.67

## Suffix -4100

### Features Pre-Connected Dual Primary Fuse Blocks

Primary 240 x 480, 230 x 460, 220 x 440 - Secondary 120, 115, 110 - Triple Rated									Primary Max Amps	Secondary Max Amps
VA	Catalog Number	Weight lbs	Dimensions (Inches/mm)			Mounting Dimensions (Inches/mm)				
			Height A	Width B	Depth C	D	E	F	240/480 V	120 V
50	HC-0050-4100	3	4.25/108	3.00/76	4.75/121	2.00/51	2.50/64	.203x.375 (5.2 x 9.5)	.21/.10	.42
75	HC-0075-4100	4	4.25/108	3.00/76	5.25/133	2.50/64	2.50/64	.203x.375 (5.2 x 9.5)	.31/.16	.63
100	HC-0100-4100	5	4.25/108	3.00/76	5.62/143	2.87/73	2.50/64	.203x.375 (5.2 x 9.5)	.42/.21	.83
150	HC-0150-4100	7	4.75/121	3.75/95	5.25/133	2.62/67	3.13/80	.203x.375 (5.2 x 9.5)	.63/.31	1.25
250	HC-0250-4100	8.5	4.75/121	3.75/95	5.62/143	2.87/73	3.13/80	.203x.375 (5.2 x 9.5)	1.04/.52	2.08
300	HC-0300-4100	9.5	4.75/121	3.75/95	6.00/152	2.87/73	3.13/80	.203x.375 (5.2 x 9.5)	1.25/.63	2.50
375	HC-0375-4100	10	5.30/135	4.50/114	5.50/140	2.75/70	3.75/95	.203x.375 (5.2 x 9.5)	1.56/.78	3.13
500	HC-0500-4100	11.5	5.25/133	4.50/114	6.00/142	3.25/83	3.75/95	.203x.375 (5.2 x 9.5)	2.08/1.04	4.17
750	HC-0750-4100	15.5	5.25/133	4.50/114	6.87/175	4.12/105	3.75/95	.203x.375 (5.2 x 9.5)	3.12/1.56	6.25
1000	HC-1000-4100	19	5.87/149	5.25/133	6.50/165	3.87/98	4.37/111	.281x562 (7.1 x 14.3)	4.16/2.08	8.33
1500	HC-1500-4100	27	5.87/149	5.25/133	7.87/200	5.12/130	4.37/111	.281x562 (7.1 x 14.3)	6.25/3.12	12.50
2000	HC-2000-4100	32	5.87/149	5.25/133	9.12/232	6.40/163	4.37/111	.281x562 (7.1 x 14.3)	8.33/4.16	16.67

Dimensions and weights may change. Consult factory for Certified Drawings.



## Suffix -4400

## Features Pre-Connected Dual Primary Fuse Blocks

Primary 208 / 240 / 480 - Secondary 120									Primary Max Amps	Secondary Max Amps
VA	Catalog Number	Weight lbs	Dimensions (Inches/mm)			Mounting Dimensions (Inches/mm)				
			Height A	Width B	Depth C	D	E	F	208/240/480 V	120 V
50	HC-0050-4400	3	4.25/108	3.00/76	5.00/127	2.25/57	2.50/64	.203x.375 (5.2 x 9.5)	.24/.21/.10	.42
75	HC-0075-4400	4	4.25/108	3.00/76	5.62/143	2.87/73	2.50/64	.203x.375 (5.2 x 9.5)	.36/.31/.16	.63
100	HC-0100-4400	5.5	4.75/121	3.75/95	5.25/133	2.50/64	3.13/80	.203x.375 (5.2 x 9.5)	.48/.42/.21	.83
150	HC-0150-4400	7.5	4.75/121	3.75/95	6.12/155	3.31/84	3.13/80	.203x.375 (5.2 x 9.5)	.72/.63/.31	1.25
250	HC-0250-4400	8.5	5.50/140	4.50/114	5.25/133	2.50/64	3.75/95	.203x.375 (5.2 x 9.5)	1.21/1.04/.52	2.08
300	HC-0300-4400	10.5	5.50/140	4.50/114	6.00/152	3.25/83	3.75/95	.203x.375 (5.2 x 9.5)	1.4/1.25/.63	2.50
375	HC-0375-4400	11.5	5.50/140	4.50/114	6.00/152	3.25/83	3.75/95	.203x.375 (5.2 x 9.5)	1.8/1.56/.78	3.13
500	HC-0500-4400	13.5	5.50/140	4.50/114	6.50/165	3.75/95	3.75/95	.203x.375 (5.2 x 9.5)	2.4/2.08/1.04	4.17
750	HC-0750-4400	18.5	6.25/159	5.25/133	6.50/165	3.75/95	4.37/111	.203x.375 (5.2 x 9.5)	3.6/3.12/1.56	6.25
1000	HC-1000-4400	20	6.25/159	5.25/133	6.75/171	4.00/102	4.37/111	.281x.562 (7.1 x 14.3)	4.8/4.16/2.08	8.33
1500	HC-1500-4400	29.5	6.25/159	5.25/133	8.50/216	5.87/149	4.37/111	.281x.562 (7.1 x 14.3)	7.2/6.25/3.12	12.50
2000	HC-2000-4400	32	5.25/133	4.25/108	8.50/216	5.93/151	3.43/87	.281x.562 (7.1 x 14.3)	9.6/8.33/4.16	16.67

### Series HC Primary Fuse Kit Installation

#### Fuse Kit FKP2

- Meets UL 508
- Meets NEC Article 450
- Uses Class CC Fuses

#### Installation Procedure

- Locate the mounting hole in the terminal block of primary side of transformer.
- Fasten FKP2 Fuse Holder to primary side of transformer terminal block with the screw provided.
- Connect the Fuse Holder leads to the transformer terminals with the jumper leads furnished.

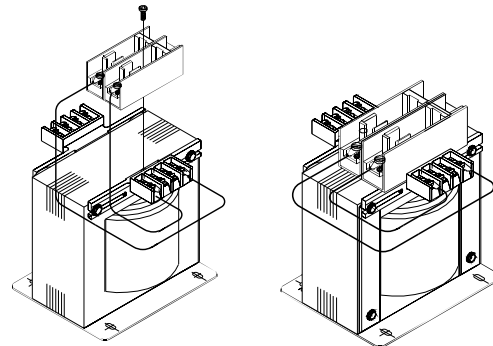

### Series HC Recommended Fuse Type by Manufacturer

Manufacturer	Bussman	Gould	Littlefuse
Primary Fuse Type	FNQ-R	ATQR / ATDR	KLDR / CCRM
Secondary Fuse Type	FNM / FNQ (250V) (500V)	TRM / ATQ (250V) (500V)	FLM / FLQ (250V) (500V)

Note: Fuses sold separately.

### Series HC Secondary Fuse Kit Installation

#### Fuse Kit FKS

- Meets UL 508
- Meets NEC Article 450
- Uses 13/32" x 1 1/2" Fuses

#### Installation Procedure

- To fuse Terminal X1, remove #10 screws in Terminals X1, XF, and unmarked terminal slot.
- Fasten Fuse Clip to transformer Terminal X1 using a #10 screw.
- Fasten a #10 screw through Fuse Clip and Jumper Terminal and into unmarked Terminal slot.
- Fasten #10 screw through Jumper Terminal and into Terminal XF.
- Connect load to terminals X2 and XF.

Dimensions and weights may change. Consult factory for Certified Drawings.

### Secondary Fuse Kit FKS Furnished with each Transformer

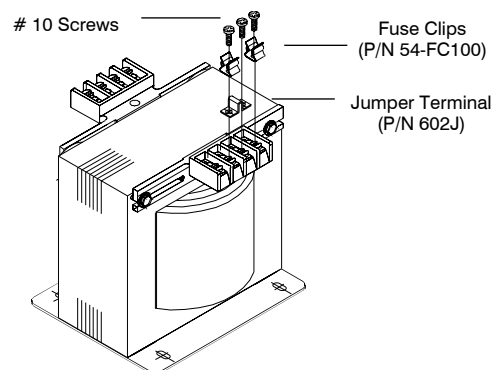

Note: Fuses sold separately.

## Series HC are shipped with Jumper Clips connected in Series

Jumpers shown stacked for Series Connections

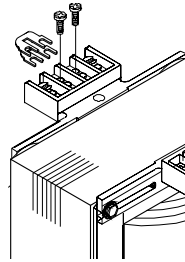

Jumpers shown spread for Parallel Connections

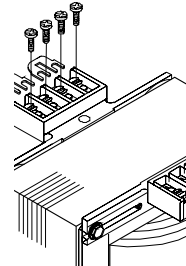

Suffix -41				
Primary		Connect Incoming Lines To	Secondary	
Voltage	Jumper		Voltage	Connect Load To
240	H1 to H3	H1 & H4	120	X1 & X2
230	&			
220	H2 to H4			
480	H2 to H3	H1 & H4	115	X1 & X2
460			110	
440				

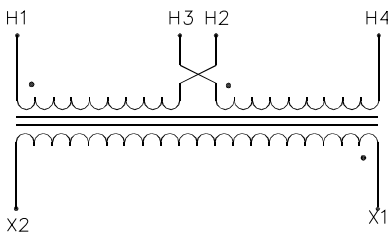

Suffix -44				
Primary		Connect Incoming Lines To	Secondary	
Voltage	Jumper		Voltage	Connect Load To
208	-	H1 & H2	120	X1 & X2
240	-	H1 & H3		
480	-	H1 & H4		

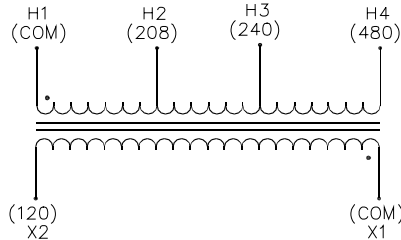

Suffix -46				
Primary		Connect Incoming Lines To	Secondary	
Voltage	Jumper		Voltage	Connect Load To
600	-	H1 & H2	120	X1 & X2

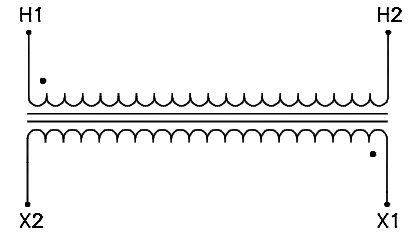

Suffix -47				
Primary		Connect Incoming Lines To	Secondary	
Voltage	Jumper		Voltage	Connect Load To
240	-	H1 & H2	120	X1 & X2
480	-	H1 & H3		
600	-	H1 & H4		

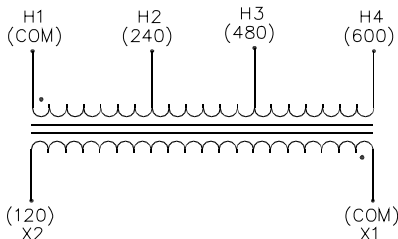

Suffix -4100				
Primary		Connect Incoming Lines To	Secondary	
Voltage	Jumper		Voltage	Connect Load To
240	H1 to H3	H1 & H4	120	XF & X2
230	&			
220	H2 to H4			
480	H2 to H3	H1 & H4	115	XF & X2
460			110	
440				

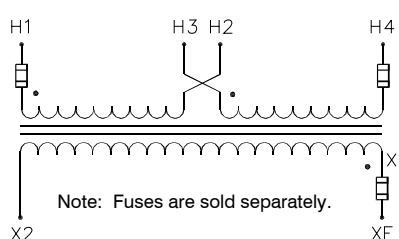

Suffix -4400				
Primary		Connect Incoming Lines To	Secondary	
Voltage	Jumper		Voltage	Connect Load To
208	-	H1 & H2	120	XF & X2
240	-	H1 & H3		
480	-	H1 & H4		

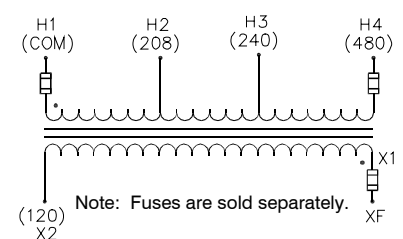



## Features



- All Copper Windings
- Rugged coil mounted screw terminals
- UL Class 105°C insulation system, 55°C temperature rise through 750 VA
- UL Class 180°C insulation system, 115°C temperature rise 1000 VA and above
- All designs rated 50 / 60 Hertz
- Primary fuse blocks and secondary fuse holders available
- Combination screw heads for ease of installation
- Meets or exceeds UL 506, NEMA ST-1 and ANSI standards
- Nonstandard designs are available by consulting the factory or your Dongan® Representative.

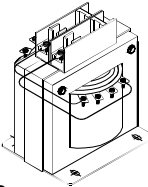
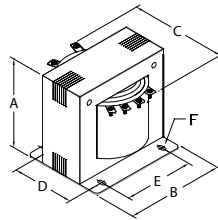

### 50 Series Voltage Combinations

Suffix	Primary	Secondary
-052	120 x 240	24
-053	240 x 480	120 Triple Rated
-054	208	120
-056	600	120
-058	220/380/415	95/115
-059	208 or 500	85/100/110
	220/380/440/550	91/110/120
	230/400/460/575	95/115/125
	240/416/480/600	99/120/130
-134	240 x 480	120 / 240 Triple Rated

## Suffix -052

Primary 120 x 240 - Secondary 24									Primary Max Amps	Secondary Max Amps
VA	Catalog Number	Weight lbs	Dimensions (Inches/mm)			Mounting Dimensions (Inches/mm)				
			Height A	Width B	Depth C	D	E	F	120/240 V	24 V
50	50-0050-052	3	2.50/64	3.00/76	3.00/76	2.00/51	2.50/64	.203x.375 (5.2 x 9.5)	.42/21	2.08
75	50-0075-052	3	2.50/64	3.00/76	3.38/86	2.50/64	2.50/64	.203x.375 (5.2 x 9.5)	.63/31	3.13
100	50-0100-052	4	2.81/71	3.38/86	3.38/86	2.38/60	2.81/71	.203x.375 (5.2 x 9.5)	.83/42	4.17
150	50-0150-052	6	3.13/80	3.75/95	3.90/99	2.63/67	3.13/80	.203x.375 (5.2 x 9.5)	1.25/63	6.25
200	50-0200-052	8	3.75/95	4.50/114	4.12/105	2.50/64	3.75/95	.203x.375 (5.2 x 9.5)	1.67/83	8.33
250	50-0250-052	9	3.75/95	4.50/114	4.25/108	2.75/70	3.75/95	.203x.375 (5.2 x 9.5)	2.08/1.04	10.42
300	50-0300-052	11	3.75/95	4.50/114	4.75/121	3.13/80	3.75/95	.203x.375 (5.2 x 9.5)	2.50/1.25	12.50
375	50-0375-052	12	3.75/95	4.50/114	5.25/133	3.63/92	3.75/95	.203x.375 (5.2 x 9.5)	3.13/1.56	15.63
500	50-0500-052	17	4.38/111	5.25/133	5.88/149	3.63/92	4.38/111	.281x562 (7.1 x 14.3)	4.17/2.08	20.83
750	50-0750-052	25	4.38/111	5.25/133	7.50/191	5.25/133	4.38/111	.281x562 (7.1 x 14.3)	6.25/3.13	31.25
1000	50-1000-052	26	4.38/111	5.25/133	7.50/191	5.25/133	4.38/111	.281x562 (7.1 x 14.3)	8.33/4.17	41.67

## Suffix -053

Primary 240 x 480, 230 x 460, 220 x 440 - Secondary 120, 115, 110 - Triple Rated									Primary Max Amps	Secondary Max Amps
VA	Catalog Number	Weight lbs	Dimensions (Inches/mm)			Mounting Dimensions (Inches/mm)				
			Height A	Width B	Depth C	D	E	F	240/480 V	120 V
50	50-0050-053	3	2.50/64	3.00/76	3.00/76	2.00/51	2.50/64	.203x.375 (5.2 x 9.5)	.21/10	.42
75	50-0075-053	3	2.50/64	3.00/76	3.38/86	2.50/64	2.50/64	.203x.375 (5.2 x 9.5)	.31/16	.63
100	50-0100-053	4	2.81/71	3.38/86	3.38/86	2.38/60	2.81/71	.203x.375 (5.2 x 9.5)	.42/21	.83
150	50-0150-053	6	3.13/80	3.75/95	3.90/99	2.63/67	3.13/80	.203x.375 (5.2 x 9.5)	.63/31	1.25
200	50-0200-053	8	3.75/95	4.50/114	4.12/105	2.50/64	3.75/95	.203x.375 (5.2 x 9.5)	.83/42	1.67
250	50-0250-053	9	3.75/95	4.50/114	4.25/108	2.75/70	3.75/95	.203x.375 (5.2 x 9.5)	1.04/52	2.08
300	50-0300-053	11	3.75/95	4.50/114	4.75/121	3.13/80	3.75/95	.203x.375 (5.2 x 9.5)	1.25/63	2.50
375	50-0375-053	12	3.75/95	4.50/114	5.25/133	3.63/92	3.75/95	.203x.375 (5.2 x 9.5)	1.56/78	3.13
500	50-0500-053	17	4.38/111	5.25/133	5.88/149	3.63/92	4.38/111	.281x562 (7.1 x 14.3)	2.08/1.04	4.17
750	50-0750-053	25	4.38/111	5.25/133	7.50/191	5.25/133	4.38/111	.281x562 (7.1 x 14.3)	3.13/1.56	6.25
1000	50-1000-053	26	4.38/111	5.25/133	7.50/191	5.25/133	4.38/111	.281x562 (7.1 x 14.3)	4.17/2.08	8.33
1500	50-1500-053	32	5.62/143	6.38/162	7.00/178	4.50/114	5.31/135	.312x.625 (7.9 x 15.9)	6.25/3.13	12.50
2000	50-2000-053	38	5.62/143	6.38/162	7.62/194	5.00/127	5.31/135	.312x.625 (7.9 x 15.9)	8.33/4.17	16.67
3000	50-3000-053	50	6.62/168	7.50/191	7.75/197	4.75/121	6.75/171	.312x.625 (7.9 x 15.9)	12.50/6.25	25.00
5000	50-5000-053	70	6.62/168	7.5/191	10.25/	6.88/	6.75/171	.312x.625 (7.9 x 15.9)	20.83/10.42	41.67

Dimensions and weights may change. Consult factory for Certified Drawings.

## Suffix -054

Primary 208 - Secondary 120									Primary Max Amps	Secondary Max Amps
VA	Catalog Number	Weight lbs	Dimensions (Inches/mm)			Mounting Dimensions (Inches/mm)				
			Height A	Width B	Depth C	D	E	F	208 V	120 V
50	50-0050-054	3	2.50/64	3.00/76	3.00/76	2.00/51	2.50/64	.203x.375 (5.2 x 9.5)	.24	.42
75	50-0075-054	3	2.50/64	3.00/76	3.38/86	2.50/64	2.50/64	.203x.375 (5.2 x 9.5)	.36	.63
100	50-0100-054	4	2.81/71	3.38/86	3.38/86	2.38/60	2.81/71	.203x.375 (5.2 x 9.5)	.48	.83
150	50-0150-054	6	3.13/80	3.75/95	3.90/99	2.63/67	3.13/80	.203x.375 (5.2 x 9.5)	.72	1.25
200	50-0200-054	8	3.75/95	4.50/114	4.12/105	2.50/64	3.75/95	.203x.375 (5.2 x 9.5)	.96	1.67
250	50-0250-054	9	3.75/95	4.50/114	4.25/108	2.75/70	3.75/95	.203x.375 (5.2 x 9.5)	1.20	2.08
300	50-0300-054	11	3.75/95	4.50/114	4.75/121	3.13/80	3.75/95	.203x.375 (5.2 x 9.5)	1.44	2.50
375	50-0375-054	12	3.75/95	4.50/114	5.25/133	3.63/92	3.75/95	.203x.375 (5.2 x 9.5)	1.80	3.13
500	50-0500-054	17	4.38/111	5.25/133	5.88/149	3.63/92	4.38/111	.281x562 (7.1 x 14.3)	2.40	4.17
750	50-0750-054	25	4.38/111	5.25/133	7.50/191	5.25/133	4.38/111	.281x562 (7.1 x 14.3)	3.61	6.25
1000	50-1000-054	26	4.38/111	5.25/133	7.50/191	5.25/133	4.38/111	.281x562 (7.1 x 14.3)	4.81	8.33
1500	50-1500-054	32	5.62/143	6.38/162	7.00/178	4.50/114	5.31/135	.312x.625 (7.9 x 15.9)	7.21	12.50
2000	50-2000-054	38	5.62/143	6.38/162	7.62/194	5.00/127	5.31/135	.312x.625 (7.9 x 15.9)	9.62	16.67
3000	50-3000-054	50	6.62/168	7.50/191	7.75/197	4.75/121	6.75/171	.312x.625 (7.9 x 15.9)	14.42	25.00

## Suffix -056

Primary 600/575/550 - Secondary 120/115/110 Triple Rated									Primary Max Amps	Secondary Max Amps
VA	Catalog Number	Weight lbs	Dimensions (Inches/mm)			Mounting Dimensions (Inches/mm)				
			Height A	Width B	Depth C	D	E	F	600 V	120 V
50	50-0050-056	3	2.50/64	3.00/76	3.00/76	2.00/51	2.50/64	.203x.375 (5.2 x 9.5)	.08	.42
75	50-0075-056	3	2.50/64	3.00/76	3.38/86	2.50/64	2.50/64	.203x.375 (5.2 x 9.5)	.13	.63
100	50-0100-056	4	2.81/71	3.38/86	3.38/86	2.38/60	2.81/71	.203x.375 (5.2 x 9.5)	.17	.83
150	50-0150-056	6	3.13/80	3.75/95	3.90/99	2.63/67	3.13/80	.203x.375 (5.2 x 9.5)	.25	1.25
200	50-0200-056	8	3.75/95	4.50/114	4.12/105	2.50/64	3.75/95	.203x.375 (5.2 x 9.5)	.33	1.67
250	50-0250-056	9	3.75/95	4.50/114	4.25/108	2.75/70	3.75/95	.203x.375 (5.2 x 9.5)	.42	2.08
300	50-0300-056	11	3.75/95	4.50/114	4.75/121	3.13/80	3.75/95	.203x.375 (5.2 x 9.5)	.50	2.50
375	50-0375-056	12	3.75/95	4.50/114	5.25/133	3.63/92	3.75/95	.203x.375 (5.2 x 9.5)	.63	3.13
500	50-0500-056	17	4.38/111	5.25/133	5.88/149	3.63/92	4.38/111	.281x562 (7.1 x 14.3)	.83	4.17
750	50-0750-056	25	4.38/111	5.25/133	7.50/191	5.25/133	4.38/111	.281x562 (7.1 x 14.3)	1.25	6.25
1000	50-1000-056	26	4.38/111	5.25/133	7.50/191	5.25/133	4.38/111	.281x562 (7.1 x 14.3)	1.67	8.33
1500	50-1500-056	32	5.62/143	6.38/162	7.00/178	4.50/114	5.31/135	.312x.625 (7.9 x 15.9)	2.50	12.50
2000	50-2000-056	38	5.62/143	6.38/162	7.62/194	5.00/127	5.31/135	.312x.625 (7.9 x 15.9)	3.33	16.67
3000	50-3000-056	50	6.62/168	7.50/191	7.75/197	4.75/121	6.75/171	.312x.625 (7.9 x 15.9)	5.00	25.00

## Suffix -058

Primary 220/380/415 - Secondary 95/115									Primary Max Amps	Secondary Max Amps
VA	Catalog Number	Weight lbs	Dimensions (Inches/mm)			Mounting Dimensions (Inches/mm)				
			Height A	Width B	Depth C	D	E	F	220/380/415 V	95/115 V
250	50-0250-058	11	3.75/95	4.50/114	4.81/122	3.38/86	3.75/95	.203x.375 (5.2 x 9.5)	1.14/66/60	2.63/2.17
500	50-0500-058	22	4.38/111	5.25/133	6.63/168	4.60/117	4.38/111	.281x562 (7.1 x 14.3)	2.27/1.32/1.20	5.26/4.35
750	50-0750-058	23	4.25/108	5.75/146	7.38/187	4.38/111	4.94/125	.281x562 (7.1 x 14.3)	3.41/1.97/1.81	7.89/6.52
1000	50-1000-058	32	5.31/135	6.38/162	6.75/171	4.50/114	5.31/135	.312x.625 (7.9 x 15.9)	4.5/2.6/2.4	10.5/8.7
1500	50-1500-058	41	6.25/159	7.50/191	6.25/159	4.00/102	6.75/171	.312x.625 (7.9 x 15.9)	6.8/3.9/3.6	15.7/13.0
2000	50-2000-058	49	6.25/159	7.50/191	7.80/198	4.75/121	6.75/171	.312x.625 (7.9 x 15.9)	9.0/5.2/4.8	21.0/17.3
3000	50-3000-058	75	6.25/159	7.50/191	9.88/251	6.88/175	6.75/171	.312x.625 (7.9 x 15.9)	13.6/7.8/7.2	31.5/26.0
5000	50-5000-058	113	7.50/191	9.00/229	9.12/232	6.93/176	7.50/191	.437x.750 (11.1 x 19.1)	22.7/13.1/12.0	52.6/43.4

Dimensions and weights may change. Consult factory for Certified Drawings.





Suffix -059

Primary - Secondary 208/500 - 85/100/110 220/380/440/550 - 91/110/120 230/400/460/575 - 95/115/125 240/416/480/600 - 99/120/130									Secondary Max Amps
VA	Catalog Number	Weight lbs	Dimensions (Inches/mm)			Mounting Dimensions (Inches/mm)			
			Height A	Width B	Depth C	D	E	F	
150	50-0250-059	11	4.38/111	5.25/133	4.57/116	2.63/	4.38/111	.281x.562 (7.1 x 14.3)	1.25
250	50-0250-059	15	4.38/111	5.25/133	5.25/133	3.38/86	4.38/111	.281x.562 (7.1 x 14.3)	2.25
375	50-0375-059	18	4.25/108	5.75/146	6.25/159	3.44/	4.94/	.281x.562 (7.1 x 14.3)	3.2
500	50-0500-059	22	4.25/108	5.75/146	6.68/	4.38/111	4.94/	.281x.562 (7.1 x 14.3)	4.5
750	50-0750-059	32	5.31/135	6.38/162	6.75/170	4.50/114	5.31/135	.312x.625 (7.9 x 15.9)	6.25
1000	50-1000-059	35	5.31/135	6.38/162	7.25/	5.00/	5.31/135	.312x.625 (7.9 x 15.9)	9
1500	50-1500-059	53	6.25/159	7.50/191	8.63/	5.25/	6.75/171	.312x.625 (7.9 x 15.9)	15
2000	50-2000-059	60	6.25/159	7.50/191	8.75/	5.80/	6.75/171	.312x.625 (7.9 x 15.9)	20
3000	50-3000-059	74	6.25/159	7.50/191	10.25/	6.88/	6.75/171	.312x.625 (7.9 x 15.9)	25

Suffix -134

Primary 240 x 480, 230 x 460, 220 x 440 - Secondary 120/240, 115/230, 110/220 - Triple Rated									Primary Max Amps	Secondary Max Amps
VA	Catalog Number	Weight lbs	Dimensions (Inches/mm)			Mounting Dimensions (Inches/mm)			240/480 V	120/240 V
			Height A	Width B	Depth C	D	E	F		
50	50-0050-134	3	2.50/64	3.00/76	3.00/76	2.00/51	2.50/64	.203x.375 (5.2 x 9.5)	.21/.10	.42/21
75	50-0075-134	3	2.50/64	3.00/76	3.38/86	2.50/64	2.50/64	.203x.375 (5.2 x 9.5)	.31/.16	.63/.31
100	50-0100-134	4	2.81/71	3.38/86	3.38/86	2.38/60	2.81/71	.203x.375 (5.2 x 9.5)	.42/.21	.83/.42
150	50-0150-134	6	3.13/80	3.75/95	3.90/99	2.63/67	3.13/80	.203x.375 (5.2 x 9.5)	.63/.31	1.25/.63
200	50-0200-134	8	3.75/95	4.50/114	4.12/105	2.50/64	3.75/95	.203x.375 (5.2 x 9.5)	.83/.42	1.67/.83
250	50-0250-134	9	3.75/95	4.50/114	4.25/108	2.75/70	3.75/95	.203x.375 (5.2 x 9.5)	1.04/.52	2.08/1.04
300	50-0300-134	11	3.75/95	4.50/114	4.75/121	3.13/80	3.75/95	.203x.375 (5.2 x 9.5)	1.25/.63	2.50/1.25
375	50-0375-134	12	3.75/95	4.50/114	5.25/133	3.63/92	3.75/95	.203x.375 (5.2 x 9.5)	1.56/.78	3.13/1.56
500	50-0500-134	17	4.38/111	5.25/133	5.88/149	3.63/92	4.38/111	.281x.562 (7.1 x 14.3)	2.08/1.04	4.17/2.08
750	50-0750-134	25	4.38/111	5.25/133	7.50/191	5.25/133	4.38/111	.281x.562 (7.1 x 14.3)	3.13/1.56	6.25/3.13
1000	50-1000-134	26	4.38/111	5.25/133	7.50/191	5.25/133	4.38/111	.281x.562 (7.1 x 14.3)	4.17/2.08	8.33/4.17
1500	50-1500-134	32	5.62/143	6.38/162	7.00/178	4.50/114	5.31/135	.312x.625 (7.9 x 15.9)	6.25/3.13	12.50/6.25
2000	50-2000-134	38	5.62/143	6.38/162	7.62/194	5.00/127	5.31/135	.312x.625 (7.9 x 15.9)	8.33/4.17	16.67/8.33
3000	50-3000-134	50	6.62/168	7.50/191	7.75/197	4.75/121	6.75/171	.312x.625 (7.9 x 15.9)	12.50/6.25	25.00/12.50

Dimensions and weights may change. Consult factory for Certified Drawings.

# 50 Series

Suffix -052				
Primary			Secondary	
Voltage	Jumper	Connect Incoming Lines To	Voltage	Connect Load To
120	H1 to H3 & H2 to H4	H1 & H4	24	X1 & X2
240	H2 to H3	H1 & H4		

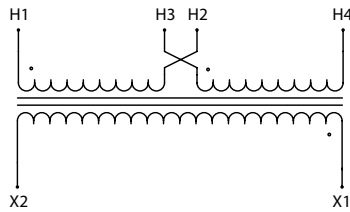

Suffix -053				
Primary			Secondary	
Voltage	Jumper	Connect Incoming Lines To	Voltage	Connect Load To
240	H1 to H3 & H2 to H4	H1 & H4	120	X1 & X2
230			115	X1 & X2
220			110	
480	H2 to H3	H1 & H4		
460				
440				

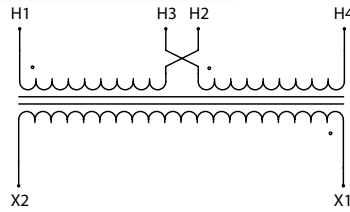

Suffix -054				
Primary			Secondary	
Voltage	Jumper	Connect Incoming Lines To	Voltage	Connect Load To
208	-	H1 & H2	120	X1 & X2

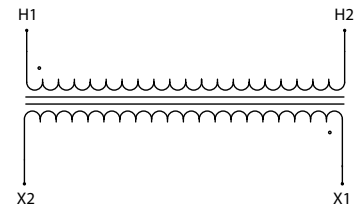

Suffix -056				
Primary			Secondary	
Voltage	Jumper	Connect Incoming Lines To	Voltage	Connect Load To
600	-	H1 & H2	120	X1 & X2
575			115	X1 & X2
550			110	X1 & X2

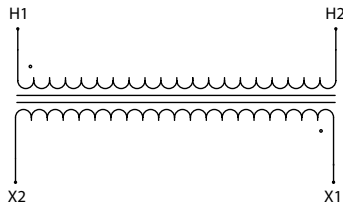

Suffix -058				
Primary			Secondary	
Voltage	Jumper	Connect Incoming Lines To	Voltage	Connect Load To
220	-	H1 & H2	95	X1 & X2
380	-	H1 & H3		
415	-	H1 & H4	115	X1 & X3

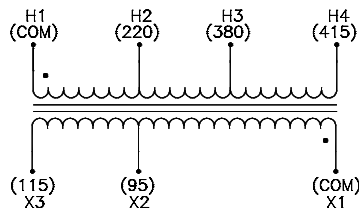

Suffix -134					
0.45			Secondary		
Voltage	Jumper	Connect Incoming Lines To	Voltage	Jumper	Connect Load To
240	H1 to H3 & H2 to H4	H1 & H4	120	X1 to X3 & X2 to X4	X1 & X4
230			115		
220			110		
480	H2 to H3	H1 & H4	120	X1 to X3 & X2 to X4	X1 & X4
460			115		
440			110		
240	H1 to H3 & H2 to H4	H1 & H4	240	X2 to X3	X1 & X4
230			230		
220			220		
480	H2 to H3	H1 & H4	240	X2 to X3	X1 & X4
460			230		
440			220		

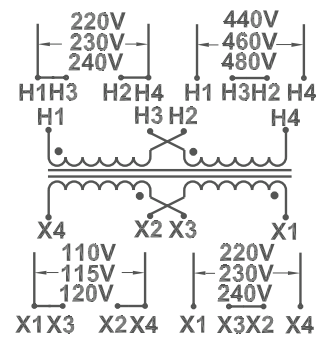

Suffix -059						
Primary				Secondary		
Connect Incoming Lines To H1 & H2	Connect Incoming Lines To H1 & H3	Connect Incoming Lines To H1 & H4	Connect Incoming Lines To H1 & H5	Connect Load To X1 & X2	Connect Load To X1 & X3	Connect Load To X1 & X4
208	-	-	500	85	100	110
220	380	440	550	91	110	120
230	400	460	575	95	115	125
240	416	480	600	99	120	130

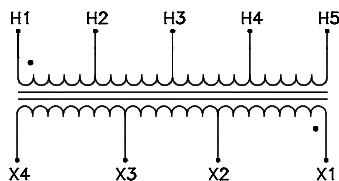

## Series 50 Primary Fuse Kit BR-734

### I Fuse Kit BR-734

- Meets UL 508
- Meets NEC Article 450
- Uses Class CC Fuses

### Installation Procedure

- Loosen bolts holding transformer to the panel backplate.
- Slide the BR-734 bracket over the transformer.
- Connect the Fuse Holder leads to the transformer terminals with the Jumper Leads furnished.

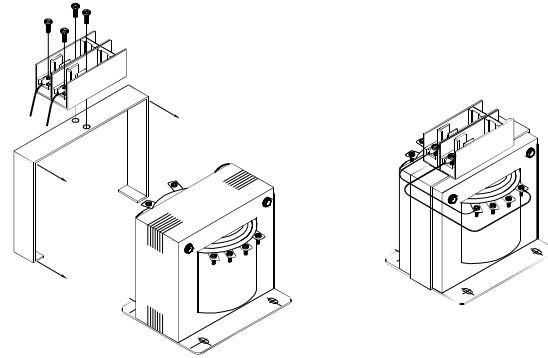

### Series 50 Recommended Fuse Type by Manufacturer

Manufacturer	Bussman	Gould	Littlefuse
Primary Fuse Type	FNQ-R	ATQR / ATDR	KLDR / CCRM
Secondary Fuse Type Fuse Holder 265-B	FNM / FNQ (250V) (500V)	TRM / ATQ (250V) (500V)	FLM / FLQ (250V) (500V)
Secondary Fuse Type Fuse Holder GLF 1 1/4	MDQ (250V)	GDL (250V)	3AB (250V)

Note: Fuses sold separately.

### Primary Fuse Holder Brackets for 50 Series

Series VA	052	053	054	056	058	059	134
50	BR-734-1	BR-734-1	BR-734-1	BR-734-1			BR-734-1
75	BR-734-1	BR-734-1	BR-734-1	BR-734-1			BR-734-1
100	BR-734-2	BR-734-2	BR-734-2	BR-734-2			BR-734-2
150	BR-734-3	BR-734-3	BR-734-3	BR-734-3		BR-734-6	BR-734-3
200	BR-734-4	BR-734-4	BR-734-4	BR-734-4			BR-734-4
250	BR-734-4	BR-734-4	BR-734-4	BR-734-4	BR-734-4	BR-734-6	BR-734-4
300	BR-734-4	BR-734-4	BR-734-4	BR-734-4			BR-734-4
375	BR-734-4	BR-734-4	BR-734-4	BR-734-4		BR-734-5	BR-734-4
500	BR-734-6	BR-734-6	BR-734-6	BR-734-6	BR-734-6	BR-734-5	BR-734-6
750	BR-734-6	BR-734-6	BR-734-6	BR-734-6	BR-734-5	BR-734-7	BR-734-6
1000	BR-734-6	BR-734-6	BR-734-6	BR-734-6	BR-734-7	BR-734-7	BR-734-6
1500		BR-734-7	BR-734-7	BR-734-7	BR-734-8	BR-734-8	BR-734-7
2000		BR-734-7	BR-734-7	BR-734-7	BR-734-8	BR-734-8	BR-734-7
3000		BR-734-8	BR-734-8	BR-734-8	BR-734-8	BR-734-8	BR-734-8
5000		BR-734-8			BR-734-9		

## Series 50 Secondary Fuse Kits

### Fuse Kit 265 B

- Meets UL 508
- Meets NEC Article 450
- Uses Class 13/32 x 1 1/2 Fuses

### Installation Procedure

- Remove the #10 screw in the transformer terminal to be fused.
- Fasten 265 B Fuse Holder to the transformer terminal with the longer #10 screw provided, as shown in the diagram.
- Connect the load lead to the terminal provided on the 265 B Fuse Holder

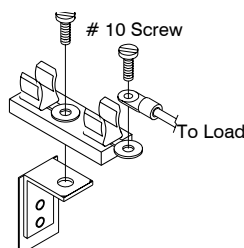

### Fuse Kit GLF 1 1/4

- Meets UL 508
- Meets NEC Article 450
- Uses Class 1/4 x 1 1/4 Fuses

### Installation Procedure

- Remove the #6 screw in the transformer terminal to be fused.
- Fasten GLF 1 1/4 Fuse Holder to the transformer terminal with the longer #6 screw provided, as shown in the diagram.
- Connect the load lead to the terminal provided on the GLF 1 1/4 Fuse Holder

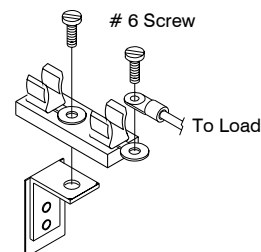

Note: Fuses sold separately.

# Selecting and Sizing an Industrial Control Transformer

## Selecting The Correct Transformer VA Capacity

Once Selection VA is calculated by one of the above methods, the selection charts on the right can be used.

Calculated Selection Inrush VA should be equal to or greater than the maximum inrush VA from the chart. To assure adequate capacity, a power factor of 40% has been employed in the selection chart.

The use of the 90% or 95% of rated secondary voltage column is recommended for transformer selection. The use of the 85% rated secondary voltage column may not provide adequate voltage output to accommodate existing below normal distribution voltages and voltage dips during equipment and motor startups.

Example:

Sizing Data:

$$\begin{aligned} \text{Sealed VA} &= 270 \text{ VA} \\ \text{Inrush VA} &= 1,728 \text{ VA} \end{aligned}$$

Using the formula in Method 1:

Selection Inrush VA

$$\begin{aligned} &= \sqrt{(\text{VA sealed})^2 + (\text{VA inrush})^2} \\ &= \sqrt{(270)^2 + (1,728)^2} \\ &= 1,749 \text{ VA} \end{aligned}$$

In the above example, at 95% of rated secondary voltage (.4 PF), the correct transformer size is 500 VA.

Using the formula in Method 2:

$$\begin{aligned} &= \text{VA Sealed} + \text{VA Inrush} \\ &= 270 + 1728 \\ &= 1,998 \text{ VA} \end{aligned}$$

In the above example, at 95% of rated secondary voltage (.4 PF), the correct transformer size is 750 VA.

Conversion to kVA:

The formula used to convert single phase VA to kVA is as follows:

$$\text{kVA} = \frac{\text{VA (Volt Amperes)}}{1000}$$

Typical Va Requirements of 3 pole, 60 Hz, 120 volt contractors are listed in the chart below:

## Selection Inrush VA Charts

Series IC Inrush VA		Selection Inrush VA at 85%, 90%, and 95% of Rated Secondary Voltage					
VA Rating	Catalog Number	20% Power Factor			40% Power Factor		
		85%	90%	95%	85%	90%	95%
50	IC-0050-xxx	330	270	210	240	200	140
75	IC-0075-xxx	520	430	340	370	310	220
100	IC-0100-xxx	840	690	540	590	480	352
150	IC-0150-xxx	1390	1150	900	1280	1030	722
250	IC-0250-xxx	2850	2300	1850	1980	1650	1060
350	IC-0350-xxx	3980	3200	2580	2900	2400	1680
500	IC-0500-xxx	7400	6130	4800	5200	4340	3200
750	IC-0750-xxx	12000	10400	8100	8800	7400	5100
1000	IC-1000-xxx	19100	15700	11400	13500	11200	7700

Series 50 Inrush VA		Selection Inrush VA at 85%, 90%, and 95% of Rated Secondary Voltage					
VA Rating	Catalog Number	20% Power Factor			40% Power Factor		
		85%	90%	95%	85%	90%	95%
50	50-0050-xxx	270	230	190	250	185	140
75	50-0075-xxx	580	480	350	460	340	250
100	50-0100-xxx	820	660	490	520	410	305
150	50-0150-xxx	1350	1000	820	1250	900	640
200	50-0200-xxx	1920	1380	840	1320	960	690
250	50-0250-xxx	2780	1990	1190	1840	1290	790
300	50-0300-xxx	3600	2680	1630	2470	1800	1070
375	50-0375-xxx	4580	3300	2050	3100	2250	1300
500	50-0500-xxx	6150	4450	2750	4350	3100	1900
750	50-0750-xxx	10200	7300	4300	8450	5500	3700
1000	50-1000-xxx	11800	8400	4600	8900	5900	3950
1500	50-1500-xxx	22400	16300	9200	16500	12900	6900
2000	50-2000-xxx	24600	16800	9800	19600	13300	7200
3000	50-3000-xxx	32500	23600	13900	26500	19600	11700
5000	50-5000-xxx	62000	46000	26800	49800	37200	29500

Series HC Inrush VA		Selection Inrush VA at 85%, 90%, and 95% of Rated Secondary Voltage					
VA Rating	Catalog Number	20% Power Factor			40% Power Factor		
		85%	90%	95%	85%	90%	95%
50	HC-0050-xxx	270	230	190	250	185	140
75	HC-0075-xxx	580	480	350	460	340	250
100	HC-0100-xxx	810	630	440	620	530	350
150	HC-0150-xxx	1350	1050	820	1250	900	640
250	HC-0250-xxx	2040	1610	1170	1940	1420	980
375	HC-0375-xxx	3240	2450	2030	2900	2050	1650
500	HC-0500-xxx	5600	4050	2900	4500	3500	2350
750	HC-0750-xxx	9300	6650	4800	7100	5650	3850
1000	HC-1000-xxx	14500	11000	7900	12600	9700	5800
1500	HC-1500-xxx	24200	18700	13500	19500	14100	9800
2000	HC-2000-xxx	37500	27500	19800	27500	20500	14000

# Selecting and Sizing an Industrial Control Transformer (cont.)

## Control Circuit Overcurrent Protection

Current North American Standards specify overcurrent protection on all control circuit transformers. These standards include the US National Electric Code®, UL 508, and the Canadian Electrical Code. Specified overcurrent protection may be accomplished by one of two options.

Option 1: Provide primary overcurrent protection based on the parameters below.

Option 2: Provide both primary and secondary overcurrent protection. When this option is followed, the primary overcurrent device should be

rated at no more than 250% of rated primary current and the secondary overcurrent device at no more than 125% of rated secondary current.

Option 2 is the preferred method of overcurrent protection, as it minimizes nuisance trips due to startup inrush.

In either method, it is recommended that Class CC, time delay primary fuses be used in order to help prevent nuisance trips.

## Recommended Primary Fuse Chart

Primary Voltage																		
VA ↓	115	120	200	208	220	230	240	277	380	400	416	440	460	480	550	575	600	VA ↓
50	1 ¼	1 ¼	¾	⅝	⅝	⅝	⅝	½	⅜	⅜	⅜	⅜	⅜	⅜	¼	¼	⅜	50
75	1 ⅝	1 ⅝	1 ⅝	1	1	⅝	⅝	⅝	½	½	½	½	⅜	⅜	⅜	⅜	⅜	75
100	2 ½	2 ¼	1 ½	1 ⅝	1 ¼	1 ¼	1 ¼	1	¾	¾	⅝	⅝	⅝	⅝	½	½	½	100
150	3 ½	3 ½	2 ¼	2	2	1 ⅝	1 ⅝	1 ⅝	1 ⅝	1 ⅝	1	1	⅝	⅝	⅝	¾	¾	150
200	5	5	3	2 ⅝	2 ½	2 ½	2 ¼	2	1 ½	1 ½	1 ⅝	1 ¼	1 ¼	1 ¼	1	1	⅝	200
250	4	4	3 ½	3 ½	3 ⅝	3 ⅝	3	2 ½	1 ⅝	1 ⅝	1 ⅝	1 ⅝	1 ⅝	1 ½	1 ¼	1 ¼	1 ¼	250
300	5	5	4 ½	4	4	3 ½	3 ½	3 ⅝	2 ¼	2 ¼	2	2	1 ⅝	1 ⅝	1 ⅝	1 ½	1 ½	300
350	5	5	5	5	4 ½	4 ½	4	3 ½	2 ½	2 ½	2 ½	2 ¼	2 ¼	2	1 ⅝	1 ⅝	1 ⅝	350
500	8	8	4 ½	5	4	4	3 ½	5	3 ½	3 ½	3 ½	3 ⅝	3 ⅝	3	2 ½	2 ½	2 ¼	500
750	10	10	7	6	6	6	5	5	5 ⅝	5 ⅝	5	5	4 ½	4 ½	4	3 ½	3 ½	750
1000	15	15	9	8	8	8	7	6	4 ½	4 ½	4	4	3 ½	3 ½	5	5	5	1000
1500	20	15	15	12	12	10	10	9	6 ¼	6 ¼	6	6	6	5	4 ½	4 ½	4	1500
2000	25	20	15	15	15	15	15	12	9	9	8	8	8	7	6	6	6	2000
3000			20	20	20	20	15	15	15	12	12	12	12	10	9	9	9	3000
5000				30	30	30	30	25	20	15	15	15	15	15	15	15	15	5000

## Recommended Secondary Fuse Chart

Secondary Voltage												
VA ↓	24	95	100	110	115	120	125	130	220	230	240	VA ↓
50	3 ⅝	⅝	⅝	¾	⅝	⅝			⅝	⅝	⅝	50
75	5	1 ¼	1 ¼	1 ⅝	1	1			½	½	½	75
100	6 ¼	1 ⅝	1 ⅝	1 ½	1 ⅝	1 ¼			¾	⅝	⅝	100
150	10	2 ½	2 ½	2 ¼	2	2			1 ⅝	1	1	150
200	12	3 ½	3 ⅝	3	2 ⅝	2 ½			1 ½	1 ⅝	1 ¼	200
250	15	4	4	3 ½	3 ½	3 ⅝			1 ⅝	1 ⅝	1 ⅝	250
300	20	5	5	4 ½	4	4			2 ¼	2	2	300
350	20	6	5 ⅝	5	5	4 ½			2 ½	2 ½	2 ¼	350
500	30	8	8	7 ½	7	6 ¼			3 ½	3 ½	3 ⅝	500
750		12	12	10	10	10			5 ⅝	5	5	750
1000		15	15	15	15	15			7	7	7	1000
1500		20	20	20	20	20			9	8	8	1500
2000		30	30	20	30	20			15	15	12	2000
3000									20	20	20	3000
5000									30	30	30	5000



# Series 50 Industrial Control Transformers

Series 50 Industrial Control Transformers are designed to the highest NEMA and industrial standards. Series 50 offer compact designs for ease of installation in hundreds of control panel and automation applications.



Series 50 are available in both domestic and export voltage combinations. Other voltage, frequency and size requirements are readily manufactured by consulting the factory or your Dongan® representative.

CE Marked, TÜV Licensed Industrial Control Transformers are featured on pgs. 82-83 in this section.

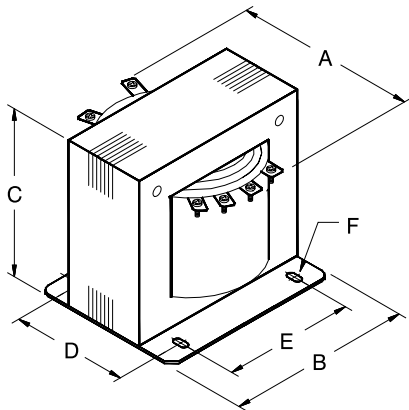

## Domestic Series:

### Features



- All copper windings.
- All designs are rated 50 / 60 Hertz.
- Rugged coil mounted screw terminals.
- Primary fuse blocks and secondary fuse holders are available and are easily installed.
- Regulation characteristics equal or exceed the highest industry standards.
- Transformers .750 kVA and below employ a UL Class 105°C insulation system with 55°C temperature rise at a maximum ambient of 40°C.
- Transformers 1.0 kVA and above are designed with a UL Class 180°C insulation system with 115°C temperature rise at a maximum ambient of 40°C.
- Nonstandard designs are available by consulting the factory or your Dongan® Representative.

### Voltage Combinations:

Suffix	Primary	Secondary
-052	120 x 240	24
-053	240 x 480	120
-054	208	120
-056	600	120
-134	240 x 480	120 / 240

### Suffix -052, 50 / 60 Hz

Primary Volts 120 X 240, Secondary Volts 24

General Information			Dimensions (inches)						Primary		Secondary		
kVA Cap.	Catalog Number	Wgt. Lbs.	A	B	C	Mounting			Pri. Max. Amps 120V / 240V	Pri. Fuse Kit	Sec. Max. Amps	Sec. Fuse Kit	Sec. Fuse Size
						D	E	F					
.050	50-0050-052	3	3.00	3.00	2.50	2.00	2.50	.203 x .375	.42 / .21	BR-734-1	2.08	GLF 1¼	2.25
.075	50-0075-052	3	3.38	3.00	2.50	2.50	2.50	.203 x .375	.63 / .31	BR-734-1	3.13	GLF 1¼	3.2
.100	50-0100-052	4	3.38	3.38	2.81	2.38	2.81	.203 x .375	.83 / .42	BR-734-2	4.17	GLF 1¼	4.5
.150	50-0150-052	6	3.90	3.75	3.13	2.63	3.13	.203 x .375	1.25 / .63	BR-734-3	6.25	GLF 1¼	6.25
.200	50-0200-052	8	4.12	4.50	3.75	2.50	3.75	.203 x .375	1.67 / .83	BR-734-4	8.33	GLF 1¼	9
.250	50-0250-052	9	4.25	4.50	3.75	2.75	3.75	.203 x .375	2.08 / 1.04	BR-734-4	10.42	GLF 1¼	10
.300	50-0300-052	11	4.75	4.50	3.75	3.13	3.75	.203 x .375	2.50 / 1.25	BR-734-4	12.50	GLF 1¼	15
.375	50-0375-052	12	5.25	4.50	3.75	3.63	3.75	.203 x .375	3.13 / 1.56	BR-734-4	16.63	GLF 1¼	20
.500	50-0500-052	17	5.88	5.25	4.38	3.63	4.38	.281 x .562	4.17 / 2.08	BR-734-6	20.83	265 B	25
.750	50-0750-052	25	7.50	5.25	4.38	5.25	4.38	.281 x .562	6.25 / 3.13	BR-734-6	31.25	265 B	30
1.0	50-1000-052	26	7.50	5.25	4.38	5.25	4.38	.281 x .562	8.33 / 4.17	BR-734-6	41.67	--	--

# Series 50 Industrial Control Transformers

## Export Series:

### Features



- All copper windings.
- All designs are rated 50/60 Hertz.
- Rugged coil mounted screw terminals.
- Primary Fuse blocks and secondary fuse holders are available and are easily installed.
- Regulation characteristics equal or exceed the highest industry standards.
- Transformers .750 kVA and below employ a UL Class 105°C insulation system with 55°C temperature rise at a maximum ambient of 40°C.
- Transformers 1.0 kVA and above are designed with a UL Class 180°C insulation system with 115°C temperature rise at a maximum ambient of 40°C.
- Nonstandard designs are available by consulting the factory or your Dongan® Representative.

### Voltage Cominations:

Suffix	Primary	Secondary
-058	220/380/415	95/115
-059	208 or 500	85/100/110
	220/380/440/550	91/110/120
	230/400/460/575	95/115/125
	240/416/480/600	99/120/130

Connection Diagrams may be found on Pg. 74

Note: Dimension C increases approximately 1 3/8" when Primary Fuse Kit BR-734-X is installed. Drawing is for dimensional purposes only. Actual terminal arrangements may vary.

Dimensions & weights may change. Consult factory for certified drawings.

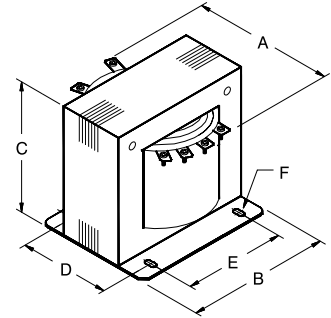

### Suffix -053, 50 / 60 Hz

Primary Volts 240 X 480, 230 X 460, 220 X 440, Secondary Volts 120/115/110

General Information			Dimensions (inches)						Primary		Secondary		
kVA Cap.	Catalog Number	Wgt. Lbs	A	B	C	Mounting			Pri. Max. Amps 240V / 480V	Pri. Fuse Kit	Sec. Max. Amps	Sec. Fuse Kit	120 V Fuse Size
						D	E	F					
.050	50-0050-053	3	3.00	3.00	2.50	2.00	2.50	.203 x .375	.21 / .10	BR-734-1	.42	GLF 1/4	.5
.075	50-0075-053	3	3.38	3.00	2.50	2.50	2.50	.203 x .375	.31 / .16	BR-734-1	.63	GLF 1/4	.6
.100	50-0100-053	4	3.38	3.38	2.81	2.38	2.81	.203 x .375	.42 / .21	BR-734-2	.83	GLF 1/4	1
.150	50-0150-053	6	3.90	3.75	3.13	2.63	3.13	.203 x .375	.63 / .31	BR-734-3	1.25	GLF 1/4	1.25
.200	50-0200-053	8	4.12	4.50	3.75	2.50	3.75	.203 x .375	.83 / .42	BR-734-4	1.67	GLF 1/4	2
.250	50-0250-053	9	4.25	4.50	3.75	2.75	3.75	.203 x .375	1.04 / .52	BR-734-4	2.08	GLF 1/4	2.25
.300	50-0300-053	11	4.75	4.50	3.75	3.13	3.75	.203 x .375	1.25 / .63	BR-734-4	2.50	GLF 1/4	2.5
.375	50-0375-053	12	5.25	4.50	3.75	3.63	3.75	.203 x .375	1.56 / .78	BR-734-4	3.13	GLF 1/4	3.2
.500	50-0500-053	17	5.88	5.25	4.38	3.63	4.38	.281 x .562	2.08 / 1.04	BR-734-6	4.17	265 B	4.5
.750	50-0750-053	25	7.50	5.25	4.38	5.25	4.38	.281 x .562	3.13 / 1.56	BR-734-6	6.25	265 B	6.25
1.0	50-1000-053	26	7.50	5.25	4.38	5.25	4.38	.281 x .562	4.17 / 2.08	BR-734-6	8.33	265 B	9
1.5	50-1500-053	32	7.00	6.38	5.62	4.50	5.31	.312 x .625	6.25 / 3.13	BR-734-7	12.50	265 B	15
2.0	50-2000-053	38	7.62	6.38	5.62	5.00	5.31	.312 x .625	6.25 / 3.13	BR-734-7	16.67	265 B	20
3.0	50-3000-053	50	7.75	7.50	6.62	4.75	6.75	.312 x .625	12.50 / 6.25	BR-734-8	25.00	265 B	25
5.0	50-5000-053	70	10.25	7.50	6.62	6.88	6.75	.312 x .625	20.83 / 10.42	BR-734-8	41.67	--	--

# Series 50 Industrial Control Transformers

## Suffix -054, 50 / 60 Hz

Primary Volts 208, Secondary Volts 120

General Information			Dimensions (inches)						Primary		Secondary		
kVA Cap.	Catalog Number	Wgt. Lbs	A	B	C	Mounting			Pri. Max. Amps 208V	Pri. Fuse Kit	Sec. Max. Amps	Sec. Fuse Kit	Sec. Fuse Size
						D	E	F					
.050	50-0050-054	3	3.00	3.00	2.50	2.00	2.50	.203 x .375	.24	BR-734-1	.42	GLF 1¼	.4
.075	50-0075-054	3	3.38	3.00	2.50	2.50	2.50	.203 x .375	.36	BR-734-1	.63	GLF 1¼	.6
.100	50-0100-054	4	3.38	3.38	2.81	2.38	2.81	.203 x .375	.48	BR-734-2	.83	GLF 1¼	1
.150	50-0150-054	6	3.90	3.75	3.13	2.63	3.13	.203 x .375	.72	BR-734-3	1.25	GLF 1¼	1.25
.200	50-0200-054	8	4.12	4.50	3.75	2.50	3.75	.203 x .375	.96	BR-734-4	1.67	GLF 1¼	2
.250	50-0250-054	9	4.25	4.50	3.75	2.75	3.75	.203 x .375	1.20	BR-734-4	2.08	GLF 1¼	2.25
.300	50-0300-054	11	4.75	4.50	3.75	3.13	3.75	.203 x .375	1.44	BR-734-4	2.50	GLF 1¼	2.5
.375	50-0375-054	12	5.25	4.50	3.75	3.63	3.75	.203 x .375	1.80	BR-734-4	3.13	GLF 1¼	3.2
.500	50-0500-054	17	5.88	5.25	4.38	3.63	4.38	.281 x .562	2.40	BR-734-6	4.17	265 B	4.5
.750	50-0750-054	25	7.50	5.25	4.38	5.25	4.38	.281 x .562	3.61	BR-734-6	6.25	265 B	6.25
1.0	50-1000-054	26	7.50	5.25	4.38	5.25	4.38	.281 x .562	4.81	BR-734-6	8.33	265 B	9
1.5	50-1500-054	32	7.00	6.38	5.62	4.50	5.31	.312 x .625	7.21	BR-734-7	12.50	265 B	15
2.0	50-2000-054	38	7.62	6.38	5.62	5.00	5.31	.312 x .625	9.62	BR-734-7	16.67	265 B	20
3.0	50-3000-054	50	7.75	7.50	6.62	4.75	6.75	.312 x .625	14.42	BR-734-8	25.00	265 B	25

Connection Diagrams may be found on Pg. 74

Note: Dimension C increases approximately 1 3/8" when Primary Fuse Kit BR-734-X is installed. Drawing is for dimensional purposes only. Actual terminal arrangements may vary.

Dimensions & weights may change. Consult factory for certified drawings.

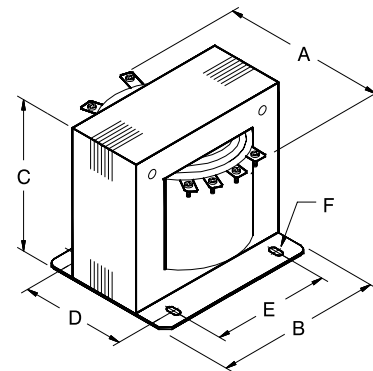

## Suffix -056, 50 / 60 Hz

Primary Volts 600/575/550, Secondary Volts 120/115/110

General Information			Dimensions (inches)						Primary		Secondary		
kVA Cap.	Catalog Number	Wgt. Lbs	A	B	C	Mounting			Pri. Max. Amps 600V	Pri. Fuse Kit	Sec. Max. Amps	Sec. Fuse Kit	120 V Fuse Size
						D	E	F					
.050	50-0050-056	3	3.00	3.00	2.50	2.00	2.50	.203 x .375	.08	BR-734-1	.42	GLF 1¼	.4
.075	50-0075-056	3	3.38	3.00	2.50	2.50	2.50	.203 x .375	.13	BR-734-1	.63	GLF 1¼	.6
.100	50-0100-056	4	3.38	3.38	2.81	2.38	2.81	.203 x .375	.17	BR-734-2	.83	GLF 1¼	1
.150	50-0150-056	6	3.90	3.75	3.13	2.63	3.13	.203 x .375	.25	BR-734-3	1.25	GLF 1¼	1.25
.200	50-0200-056	8	4.12	4.50	3.75	2.50	3.75	.203 x .375	.33	BR-734-4	1.67	GLF 1¼	2
.250	50-0250-056	9	4.25	4.50	3.75	2.75	3.75	.203 x .375	.42	BR-734-4	2.08	GLF 1¼	2.25
.300	50-0300-056	11	4.75	4.50	3.75	3.13	3.75	.203 x .375	.50	BR-734-4	2.50	GLF 1¼	2.5
.375	50-0375-056	12	5.25	4.50	3.75	3.63	3.75	.203 x .375	.63	BR-734-4	3.13	GLF 1¼	3.2
.500	50-0500-056	17	5.88	5.25	4.38	3.63	4.38	.281 x .562	.83	BR-734-6	4.17	265 B	4.5
.750	50-0750-056	25	7.50	5.25	4.38	5.25	4.38	.281 x .562	1.25	BR-734-6	6.25	265 B	6.25
1.0	50-1000-056	26	7.50	5.25	4.38	5.25	4.38	.281 x .562	1.67	BR-734-6	8.33	265 B	9
1.5	50-1500-056	32	7.00	6.38	5.62	4.50	5.31	.312 x .625	2.50	BR-734-7	12.50	265 B	15
2.0	50-2000-056	38	7.62	6.38	5.62	5.00	5.31	.312 x .625	3.33	BR-734-7	16.67	265 B	20
3.0	50-3000-056	50	7.75	7.50	6.62	4.75	6.75	.312 x .625	5.00	BR-734-8	25.00	265 B	25

# Series 50 Industrial Control Transformers

## Suffix -058, 50 / 60 Hz

Primary Volts 220 / 380 / 415, Secondary Volts 95 / 115

General Information			Dimensions (inches)						Primary		Secondary		
kVA Cap.	Catalog Number	Wgt. Lbs	A	B	C	Mounting			Pri. Max. Amps 220V / 380V / 415	Pri. Fuse Kit	Sec. Max. Amps	Sec. Fuse Kit	115 V Fuse Size
						D	E	F					
.250	50-0250-058	11	4.81	4.50	3.75	3.38	3.75	.203 x .375	1.14 / .66 / .60	BR-734-4	2.17	GLF 1¼	2.25
.500	50-0500-058	22	6.63	5.25	4.38	4.60	4.38	.281 x .562	2.27 / 1.32 / 1.20	BR-734-6	4.35	265 B	4.5
.750	50-0750-058	23	7.38	5.75	4.25	4.38	4.94	.281 x .562	3.41 / 1.97 / 1.81	BR-734-5	6.52	265 B	7
1.0	50-1000-058	32	6.75	6.38	5.31	4.50	5.31	.312 x .625	4.55 / 2.63 / 2.41	BR-734-7	8.70	265 B	9
1.5	50-1500-058	41	6.25	7.50	6.25	4.00	6.75	.312 x .625	6.82 / 3.95 / 3.61	BR-734-8	13.04	265 B	15
2.0	50-2000-058	49	7.80	7.50	6.25	4.75	6.75	.312 x .625	9.09 / 5.26 / 4.82	BR-734-8	17.39	265 B	20
3.0	50-3000-058	75	9.88	7.50	6.25	6.88	6.75	.312 x .625	13.64 / 7.89 / 7.23	BR-734-8	26.09	265 B	30
5.0	50-5000-058	113	9.12	9.00	7.50	6.93	7.50	.437 x .750	22.73 / 13.16 / 12.05	BR-734-9	43.48	--	--

## Suffix -059, 50 / 60 Hz

Primary Volts 208/500  
220/380/440/550  
230/400/460/575  
240/416/480/600

Secondary Volts 85/100/110  
91/110/120  
95/115/125  
99/120/130

General Information			Dimensions (inches)						Primary		Secondary		
kVA Cap.	Catalog Number	Wgt. Lbs	A	B	C	Mounting			Pri. Fuse Kit	Sec. Max. Amps	Sec. Fuse Kit	120 V Fuse Size	
						D	E	F					
.150	50-0150-059	11	4.57	5.25	4.38	2.63	4.38	.281 x .562	BR-734-6	1.25	265 B	1.25	
.250	50-0250-059	15	5.25	5.25	4.38	3.38	4.38	.281 x .562	BR-734-6	2.08	265 B	2.25	
.375	50-0375-059	18	6.25	5.75	4.25	3.44	4.94	.281 x .562	BR-734-5	3.13	265 B	3.2	
.500	50-0500-059	22	6.68	5.75	4.25	4.38	4.94	.281 x .562	BR-734-5	4.17	265 B	4.5	
.750	50-0750-059	32	6.75	6.38	5.31	4.50	5.31	.312 x .625	BR-734-7	6.25	265 B	6.25	
1.0	50-1000-059	35	7.25	6.38	5.31	5.00	5.31	.312 x .625	BR-734-7	8.33	265 B	9	
1.5	50-1500-059	53	8.63	7.50	6.25	5.25	6.75	.312 x .625	BR-734-8	12.5	265 B	15	
2.0	50-2000-059	60	8.75	7.50	6.25	5.80	6.75	.312 x .625	BR-734-8	16.67	265 B	20	
3.0	50-3000-059	74	10.25	7.50	6.25	6.88	6.75	.312 x .625	BR-734-8	25.00	265 B	25	

## Suffix -134, 50 / 60 Hz

Primary Volts 240 X 480, 230 X 460, 220 X 440,  
Secondary Volts 120/240,115/230,110/220

General Information			Dimensions (inches)						Primary		Secondary		
kVA Cap.	Catalog Number	Wgt. Lbs	A	B	C	Mounting			Pri. Max. Amps 240V / 480V	Pri. Fuse Kit	Sec. Max. Amps 120V / 240V	Sec. Fuse Kit	120 V Fuse Size
						D	E	F					
.050	50-0050-134	3	3.00	3.00	2.50	2.00	2.50	.203 x .375	.21 / .10	BR-734-1	.42 / .21	GLF 1¼	.5
.075	50-0075-134	3	3.38	3.00	2.50	2.50	2.50	.203 x .375	.31 / .16	BR-734-1	.63 / .31	GLF 1¼	.6
.100	50-0100-134	4	3.38	3.38	2.81	2.38	2.81	.203 x .375	.42 / .21	BR-734-2	.83 / .42	GLF 1¼	1
.150	50-0150-134	6	3.90	3.75	3.13	2.63	3.13	.203 x .375	.63 / .31	BR-734-3	1.25 / .63	GLF 1¼	1.25
.200	50-0200-134	8	4.12	4.50	3.75	2.50	3.75	.203 x .375	.83 / .42	BR-734-4	1.67 / .83	GLF 1¼	2
.250	50-0250-134	9	4.25	4.50	3.75	2.75	3.75	.203 x .375	1.04 / .52	BR-734-4	2.08 / 1.04	GLF 1¼	2.25
.300	50-0300-134	11	4.75	4.50	3.75	3.13	3.75	.203 x .375	1.25 / .63	BR-734-4	2.50 / 1.25	GLF 1¼	2.5
.375	50-0375-134	12	5.25	4.50	3.75	3.63	3.75	.203 x .375	1.56 / .78	BR-734-4	3.13 / 1.56	GLF 1¼	3.2
.500	50-0500-134	17	5.88	5.25	4.38	3.63	4.38	.281 x .562	2.08 / 1.04	BR-734-6	4.17 / 2.08	265 B	4.5
.750	50-0750-134	25	7.50	5.25	4.38	5.25	4.38	.281 x .562	3.13 / 1.56	BR-734-6	6.25 / 3.13	265 B	6.25
1.0	50-1000-134	26	7.50	5.25	4.38	5.25	4.38	.281 x .562	4.17 / 2.08	BR-734-6	8.33 / 4.17	265 B	9
1.5	50-1500-134	32	7.00	6.38	5.62	4.50	5.31	.312 x .625	6.25 / 3.13	BR-734-7	12.50 / 6.25	265 B	15
2.0	50-2000-134	38	7.62	6.38	5.62	5.0	5.31	.312 x .625	6.25 / 3.13	BR-734-7	16.67 / 8.33	265 B	20
3.0	50-3000-134	50	7.75	7.50	6.62	4.75	6.75	.312 x .625	12.50 / 6.25	BR-734-8	25.00 / 12.50	265 B	25

# Series 50 Industrial

Suffix -052				
Primary			Secondary	
Voltage	Jumper	Connect Incoming Lines To	Voltage	Connect Load To
120	H1 to H3 & H2 to H4	H1 & H4	24	X1 & X2
240	H2 to H3	H1 & H4	24	X1 & X2

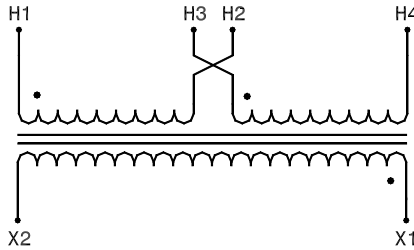

Suffix -053				
Primary			Secondary	
Voltage	Jumper	Connect Incoming Lines To	Voltage	Connect Load To
480 460 440	H2 to H3	H1 & H4	120 115 110	X1 & X2
240 230 220	H1 to H3 H2 to H4	H1 & H4	120 115 110	X1 & X2

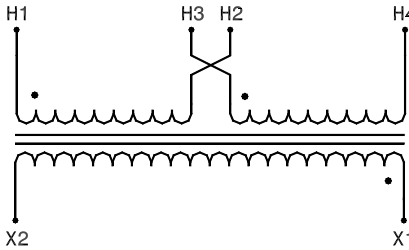

Suffix -054				
Primary			Secondary	
Voltage	Jumper	Connect Incoming Lines To	Voltage	Connect Load To
208	---	H1 & H2	120	X1 & X2

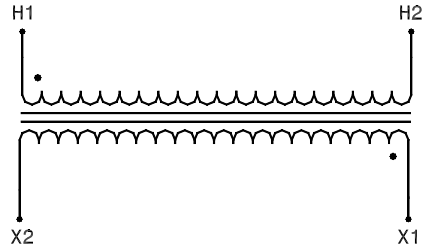

Suffix -056				
Primary			Secondary	
Voltage	Jumper	Connect Incoming Lines To	Voltage	Connect Load To
600	---	H1 & H2	120	X1 & X2

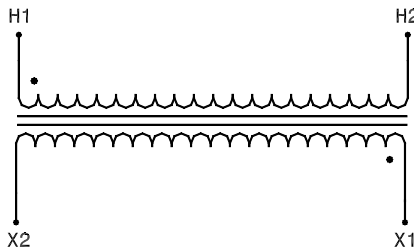

Suffix -058				
Primary			Secondary	
Voltage	Jumper	Connect Incoming Lines To	Voltage	Connect Load To
220	---	H1 & H2	95	X1 & X2
380	---	H1 & H3		
415	---	H1 & H4	115	X1 & X3

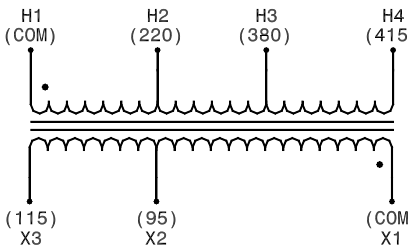

Suffix -134					
Primary			Secondary		
Voltage	Jumper	Connect Incoming Lines To	Voltage	Jumper	Connect Load To
240 230 220	H1 to H3 & H2 to H4	H1 & H4	120 115 110	X1 to X3 & X2 to X4	X1 & X4
480 460 440	H2 to H3	H1 & H4	120 115 110	X1 to X3 & X2 to X4	X1 & X4
240 230 220	H1 to H3 & H2 to H4	H1 & H4	240 230 220	X2 to X3	X1 & X4
480 460 440	H2 to H3	H1 & H4	240 230 220	X2 to X3	X1 & X4

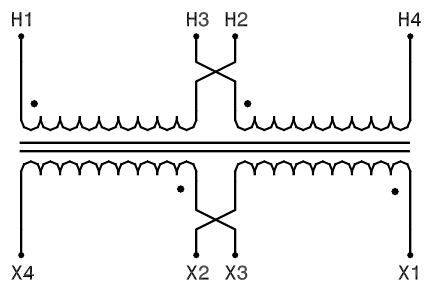

Suffix -059						
Primary				Secondary		
Connect Incoming Lines To H1 & H2	Connect Incoming Lines To H1 & H3	Connect Incoming Lines To H1 & H4	Connect Incoming Lines To H1 & H5	Connect Load To X1 & X2	Connect Load To X1 & X3	Connect Load To X1 & X4
208			500	85	100	110
220	380	440	550	91	110	120
230	400	460	575	95	115	125
240	416	480	600	99	120	130

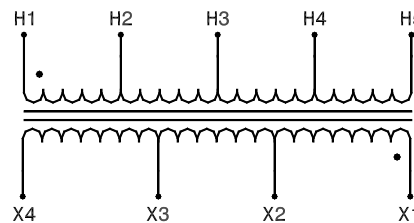



# Series 50 Industrial Control Transformers

## Series 50 Primary Fuse Kit

### Fuse Kit BR-734

- Meets UL 508
- Meets NEC Article 450
- Uses Class CC Fuses

#### Installation Procedure

- Loosen bolts holding transformer to the panel backplate.
- Slide the BR-734 bracket over the transformer.
- Retighten mounting bolts.
- Connect the fuse holder leads to the transformer terminals with the jumper leads furnished.

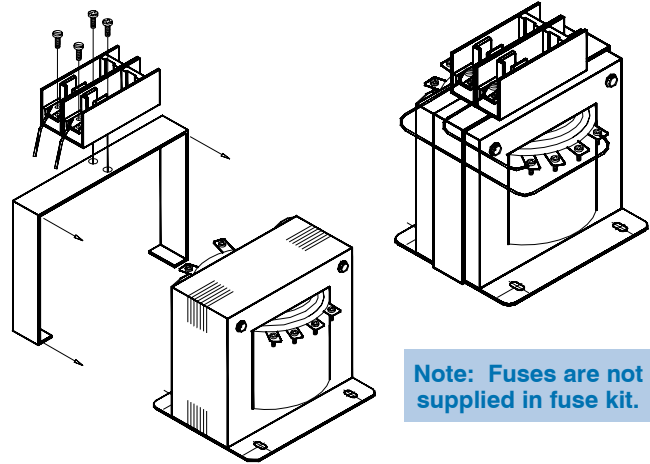

## Series 50 Secondary Fuse Kits

### Fuse Kit GLF 1 1/4

- Meets UL 508
- Meets NEC Article 450
- Uses 1/4" x 1 1/4" Fuses

#### Installation Procedure

- Remove #6 screw in the transformer terminal to be fused.
- Fasten GLF 1 1/4 fuse holder to transformer terminal with the longer #6 screw provided, as shown in the diagram.
- Connect the load lead to the terminal provided on the GLF 1 1/4 fuse holder.

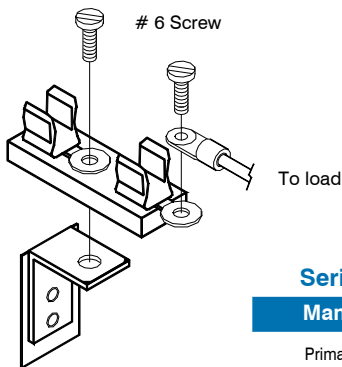

Note: Fuses are not supplied in fuse kit.

### Fuse Kit 265B

- Meets UL 508
- Meets NEC Article 450
- Uses 13/32" x 1 1/2" Fuses

#### Installation Procedure

- Remove #10 screw in the transformer terminal to be fused.
- Fasten 265B fuse holder to transformer terminal with the longer #10 screw provided, as shown in the diagram.
- Connect the load lead to the terminal provided on the 265B fuse holder.

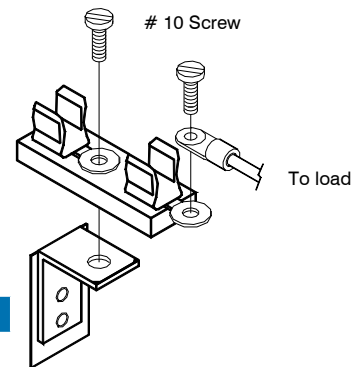

#### Series 50 Recommended Fuse Type By Manufacturer

Manufacturer	Bussman	Gould	Littlefuse
Primary Fuse Type	FNQ-R	ATQR / ATDR	KLDR / CCRM
Secondary Fuse Type Fuse Holder 265-B	FNM / FNQ (250V) (500V)	TRM / ATQ (250V) (500V)	FLM / FLQ (250V) (500V)
Secondary Fuse Type Fuse Holder GLF-1 1/4	MDQ (250V)	GDL (250V)	3AB (250V)

# Series HC Industrial Control Transformers

Series HC Industrial Control Transformers feature a molded, barrier type terminal board for easy connections of both line and load as well as various fusing kits for both primary and secondary. In addition, Series HC offer convenient jumper clips for series/parallel connections. These features allow the designer to simplify control panel fusing designs and minimize transformer installation time and cost.

Series suffix -4100 and -4400 are conveniently shipped with both primary and secondary fuse holders installed, allowing further cost reduction to the OEM.

All Series HC transformers are UL and CUL approved. CE Marked, TÜV Licensed Industrial Control Transformers are featured on pgs. 82 - 83 in this section.

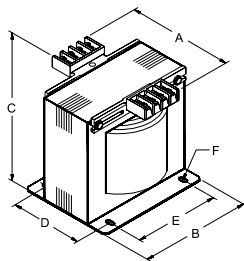

Outline Drawing  
HC Suffix -41,-44,-46,-47

Jumpers Shown Stacked for Series Connections

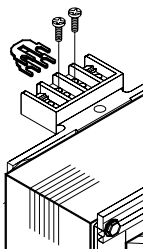

Jumpers Shown Spread for Parallel Connections

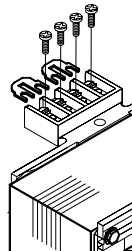

Series HC are shipped with Jumper Clips connected in series.

## Features



- All copper windings.
- Core mounted, barrier type terminal strips.
- Series/parallel jumper clips provided.
- Secondary fuse kits (FKS) furnished.
- Primary fuse kits (FKP2) are available and are easily installed.
- Regulation characteristics equal or exceed the highest industry standards.
- Grain oriented, silicon steel cores minimize core losses.
- Transformers .050 kVA to .150 kVA employ a UL Class 180°C insulation system with 55°C temperature rise at a maximum ambient of 40°C.
- Transformers .250 kVA and above are designed with a UL Class 180°C insulation system with 115°C temperature rise at a maximum ambient of 40°C.
- Nonstandard designs are available by consulting the factory or your Dongan® Representative.

### Voltage Combinations:

Suffix	Primary	Secondary
-41	240 x 480	120
-44	208 / 240 / 480	120
-46	600	120
-47	240 / 480 / 600	120

### Suffix -41

Primary Volts 240 X 480, 230 X 460, 220 X 440, Secondary Volts 120/115/110

General Information				Dimensions (inches)						Primary		Secondary		
kVA Cap.	Catalog Number	Hz.	Wgt. Lbs	A	B	C	Mounting			Pri. Max. Amps 240V / 480	Pri. Fuse Kit	Sec. Max. Amps	Sec. Fuse Kit	Sec. Fuse Size
							D	E	F					
.050	HC-0050-41	50/60	3.0	4.75	3.00	3.25	2.00	2.50	.203 x .375	.21 / .10	FKP2	.42	Included	.5
.075	HC-0075-41	50/60	4.0	5.25	3.00	3.25	2.50	2.50	.203 x .375	.31 / .16	FKP2	.63	Included	.6
.100	HC-0100-41	50/60	5.0	5.62	3.00	3.25	2.87	2.50	.203 x .375	.42 / .21	FKP2	.83	Included	1
.150	HC-0150-41	50/60	7.0	5.25	3.75	3.75	2.62	3.13	.203 x .375	.63 / .31	FKP2	1.25	Included	1.25
.250	HC-0250-41	50/60	8.5	5.62	3.75	3.75	2.87	3.13	.203 x .375	1.04 / .52	FKP2	2.08	Included	2.25
.300	HC-0300-41	50/60	9.5	6.00	3.75	3.75	3.25	3.13	.203 x .375	1.25 / .63	FKP2	2.50	Included	2.5
.375	HC-0375-41	50/60	10.0	5.50	4.50	4.30	2.80	3.80	.203 x .375	1.56 / .78	FKP2	3.13	Included	3.2
.500	HC-0500-41	50/60	11.5	6.00	4.50	4.25	3.25	3.75	.203 x .375	2.08 / 1.04	FKP2	4.17	Included	4.5
.750	HC-0750-41	50/60	15.5	6.87	4.50	4.25	4.12	3.75	.203 x .375	3.12 / 1.56	FKP2	6.25	Included	6.25
1.0	HC-1000-41	60	19.0	6.50	5.25	4.87	3.87	4.37	.281 x .562	4.16 / 2.08	FKP2	8.33	Included	9
1.5	HC-1500-41	60	27.0	7.87	5.25	4.87	5.12	4.37	.281 x .562	6.25 / 3.12	FKP2	12.50	Included	15
2.0	HC-2000-41	60	31.5	9.12	5.25	4.87	6.4	4.37	.281 x .562	8.33 / 4.16	FKP2	16.67	Included	20

# Series HC Industrial Control Transformers

## Suffix -4100 & -4400

### Features



Series -4100, and -4400: Factory Pre-Connected Primary & Secondary Fusing

- All copper windings.
- Core mounted, barrier type terminal strips.
- Series/parallel jumper clips provided on -4100.
- Dual primary fuse holder and single secondary fuse holder are factory assembled for added convenience.
- Regulation characteristics equal or exceed the

highest industry standards.

- Grain oriented, silicon steel cores minimize core losses.
- Transformers .050 kVA to .150 kVA employ a UL Class 180°C insulation system with 55°C temperature rise at a maximum ambient of 40°C.
- Transformers .250 kVA and above are designed with a UL Class 180°C insulation system with 115°C temperature rise at a maximum ambient of 40°C.
- Nonstandard designs are available by consulting the factory or your Dongan® Representative.

### Voltage Combinations:

Suffix	Primary	Secondary
-4100	240 x 480	120
-4400	208 / 240 / 480	120

## Suffix -4100

### With Pre-connected Dual Primary Fuse Blocks & Secondary Fuse Holder

Primary Volts 240 X 480, 230 X 460, 220 X 440,  
Secondary Volts 120/115/110

General Information				Dimensions (inches)						Primary		Secondary		
kVA Cap.	Catalog Number	Hz.	Wgt. Lbs	A	B	C	Mounting			Pri. Max. Amps 240V / 480V	Pri. Fuse Kit	Sec. Max. Amps	Sec. Fuse Kit	Sec. Fuse Size
							D	E	F					
.050	HC-0050-4100	50/60	3.0	4.75	3.00	4.25	2.00	2.50	.203 x .375	.21 / .10	Installed	.42	Installed	.5
.075	HC-0075-4100	50/60	4.0	5.25	3.00	4.25	2.50	2.50	.203 x .375	.31 / .16	Installed	.63	Installed	.6
.100	HC-0100-4100	50/60	5.0	5.62	3.00	4.25	2.87	2.50	.203 x .375	.42 / .21	Installed	.83	Installed	1
.150	HC-0150-4100	50/60	7.0	5.25	3.75	4.75	2.62	3.13	.203 x .375	.63 / .31	Installed	1.25	Installed	1.25
.250	HC-0250-4100	50/60	8.5	5.62	3.75	4.75	2.87	3.13	.203 x .375	1.04 / .52	Installed	2.08	Installed	2.25
.300	HC-0300-4100	50/60	9.5	6.00	3.75	4.75	2.87	3.13	.203 x .375	1.25 / .63	Installed	2.08	Installed	2.25
.375	HC-0375-4100	50/60	10.0	5.30	4.50	5.30	2.80	3.80	.203 x .375	1.56 / .78	Installed	3.13	Installed	3.2
.500	HC-0500-4100	50/60	11.5	6.00	4.50	5.25	3.25	3.75	.203 x .375	2.08 / 1.04	Installed	4.17	Installed	4.5
.750	HC-0750-4100	50/60	15.5	6.87	4.50	5.25	4.12	3.75	.203 x .375	3.12 / 1.56	Installed	6.25	Installed	6.25
1.0	HC-1000-4100	60	19.0	6.50	5.25	5.87	3.87	4.37	.281 x .562	4.16 / 2.08	Installed	8.33	Installed	9
1.5	HC-1500-4100	60	27.0	7.87	5.25	5.87	5.12	4.37	.281 x .562	6.25 / 3.12	Installed	12.50	Installed	15
2.0	HC-2000-4100	60	31.5	9.12	5.25	5.87	6.43	4.37	.281 x .562	8.33 / 4.16	Installed	16.67	Installed	20

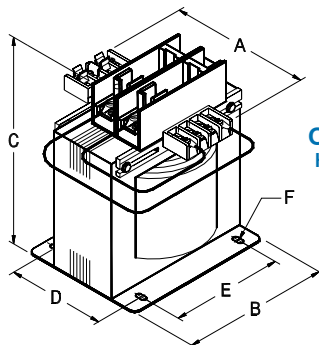

Outline Drawing  
HC Suffix -4100, -4400

Connection Diagrams may be found on  
Pg. 80

# Series HC Industrial Control Transformers

## Suffix -44

Primary Volts 208/240/480, Secondary Volts 120

General Information				Dimensions (inches)						Primary		Secondary		
kVA Cap.	Catalog Number	Hz.	Wgt. Lbs.	A	B	C	Mounting			Pri. Max. Amps 208/240V/480V	Pri. Fuse Kit	Sec. Max. Amps	Sec. Fuse Kit	Sec. Fuse Size
							D	E	F					
.050	HC-0050-44	50/60	3.0	5.00	3.00	3.25	2.25	2.50	.203 x .375	.24 / .21 / .10	FKP2	.42	Included	.5
.075	HC-0075-44	50/60	4.0	5.62	3.00	3.25	2.87	2.50	.203 x .375	.36 / .31 / .16	FKP2	.63	Included	.6
.100	HC-0100-44	50/60	5.5	5.25	3.75	3.75	2.50	3.13	.203 x .375	.48 / .42 / .21	FKP2	.83	Included	1
.150	HC-0150-44	50/60	7.5	6.12	3.75	3.75	3.31	3.12	.203 x .375	.72 / .63 / .31	FKP2	1.25	Included	1.25
.250	HC-0250-44	50/60	8.5	5.25	4.50	4.30	2.50	3.75	.203 x .375	1.21 / 1.04 / .52	FKP2	2.08	Included	2.25
.300	HC-0300-44	50/60	10.5	6.00	4.50	4.30	3.25	3.75	.203 x .375	1.4 / 1.25 / .63	FKP2	2.50	Included	2.5
.375	HC-0375-44	50/60	11.5	6.00	4.50	4.30	3.25	3.75	.203 x .375	1.8 / 1.56 / .78	FKP2	3.13	Included	3.2
.500	HC-0500-44	50/60	13.5	6.50	4.50	4.30	3.75	3.75	.203 x .375	2.4 / 2.08 / 1.04	FKP2	4.17	Included	4.5
.750	HC-0750-44	50/60	18.5	6.50	5.25	4.87	3.75	4.37	.203 x .375	3.6 / 3.12 / 1.56	FKP2	6.25	Included	6.25
1.0	HC-1000-44	60	20.0	6.75	5.25	4.87	4.00	4.37	.281 x .562	4.8 / 4.16 / 2.08	FKP2	8.33	Included	9
1.5	HC-1500-44	60	29.5	8.50	5.25	4.87	5.87	4.37	.281 x .562	7.2 / 6.25 / 3.12	FKP2	12.50	Included	15
2.0	HC-2000-44	60	32.0	8.50	4.25	6.25	5.93	3.43	.281 x .562	9.6 / 4.17 / 4.16	FKP2	16.67	Included	20

## Suffix -4400

With Pre-Connected Dual Primary Fuse Blocks & Secondary Fuse Holder\* Primary Volts 208/240/480, Secondary Volts 120

General Information				Dimensions (inches)						Primary		Secondary		
kVA Cap.	Catalog Number	Hz.	Wgt. Lbs.	A	B	C	Mounting			Pri. Max. Amps 208/240V/480V	Pri. Fuse Kit*	Sec. Max. Amps	Sec. Fuse Kit	Sec. Fuse Size
							D	E	F					
.050	HC-0050-4400	50/60	3.0	5.00	3.00	4.25	2.25	2.50	.203 x .375	.24 / .21 / .10	Installed	.42	Installed	.5
.075	HC-0075-4400	50/60	4.0	5.62	3.00	4.25	2.87	2.50	.203 x .375	.36 / .31 / .16	Installed	.63	Installed	.6
.100	HC-0100-4400	50/60	5.5	5.25	3.75	4.75	2.50	3.12	.203 x .375	.48 / .42 / .21	Installed	.83	Installed	1
.150	HC-0150-4400	50/60	7.5	6.12	3.75	4.75	3.31	3.12	.203 x .375	.72 / .63 / .31	Installed	1.25	Installed	1.25
.250	HC-0250-4400	50/60	8.5	5.25	4.50	5.50	2.50	3.75	.203 x .375	1.21 / .83 / .42	Installed	2.08	Installed	2.25
.300	HC-0300-4400	50/60	9.5	6.00	4.50	5.50	3.25	3.75	.203 x .375	1.4 / 1.25 / .63	Installed	2.50	Installed	2.5
.375	HC-0375-4400	50/60	11.5	6.00	4.50	5.50	3.25	3.75	.203 x .375	1.8 / 1.56 / .78	Installed	3.13	Installed	3.2
.500	HC-0500-4400	50/60	13.5	6.50	4.50	5.50	3.75	3.75	.203 x .375	2.4 / 2.08 / 1.04	Installed	4.17	Installed	4.5
.750	HC-0750-4400	50/60	18.5	6.50	5.25	6.25	3.75	4.37	.203 x .375	3.6 / 3.12 / 1.56	Installed	6.25	Installed	6.25
1.0	HC-1000-4400	60	20.0	6.75	5.25	6.25	4.00	4.37	.281 x .562	4.8 / 4.16 / 2.08	Installed	8.33	Installed	9
1.5	HC-1500-4400	60	29.5	8.50	5.25	6.25	5.87	4.37	.281 x .562	7.2 / 6.25 / 3.12	Installed	12.50	Installed	15
2.0	HC-2000-4400	60	32.0	8.50	4.25	5.25	5.93	3.43	.281 x .562	9.6 / 4.17 / 4.16	Installed	16.67	Installed	20

\*Fuse block is factory preconnected on 480 volt terminals.

## Suffix -46

Primary Volts 600/575/550, Secondary Volts 120/115/110

General Information				Dimensions (inches)						Primary		Secondary		
kVA Cap.	Catalog Number	Hz.	Wgt. Lbs.	A	B	C	Mounting			Pri. Max. Amps 600V	Pri. Fuse Kit	Sec. Max. Amps	Sec. Fuse Kit	Sec. Fuse Size
							D	E	F					
.050	HC-0050-46	50/60	3.0	4.75	3.00	3.25	2.00	2.50	.203 x .375	.08	FKP2	.42	Included	.5
.075	HC-0075-46	50/60	4.0	5.25	3.00	3.25	2.50	2.50	.203 x .375	.13	FKP2	.63	Included	.6
.100	HC-0100-46	50/60	5.0	5.62	3.00	3.25	2.87	2.50	.203 x .375	.17	FKP2	.83	Included	1
.150	HC-0150-46	50/60	7.0	5.25	3.75	3.75	2.62	3.13	.203 x .375	.25	FKP2	1.25	Included	1.25
.250	HC-0250-46	50/60	8.5	5.62	3.75	3.75	2.87	3.13	.203 x .375	.42	FKP2	2.08	Included	2.25
.375	HC-0375-46	50/60	10.0	5.30	4.50	4.30	2.80	3.80	.203 x .375	.63	FKP2	3.13	Included	3.2
.500	HC-0500-46	50/60	11.5	6.00	4.50	4.25	3.25	3.75	.203 x .375	.83	FKP2	4.17	Included	4.5
.750	HC-0750-46	50/60	15.5	6.87	4.50	4.25	4.12	3.75	.203 x .375	1.3	FKP2	6.25	Included	6.25
1.0	HC-1000-46	60	19.0	6.50	5.25	4.87	3.87	4.37	.281 x .562	1.7	FKP2	8.33	Included	9
1.5	HC-1500-46	60	27.0	7.87	5.25	4.87	5.12	4.37	.281 x .562	2.5	FKP2	12.50	Included	15
2.0	HC-2000-46	60	31.5	9.12	5.25	4.87	6.43	4.37	.281 x .562	3.3	FKP2	16.67	Included	20

# Series HC Industrial Control Transformers

## Suffix -47

Primary Volts 240/480/600, 230/460/575, 220/440/550

Secondary Volts 120/115/110

General Information				Dimensions (inches)						Primary		Secondary		
kVA Cap.	Catalog Number	Hz.	Wgt. Lbs	A	B	C	Mountin			Pri. Max. Amps 240/480/600V	Pri. Fuse Kit	Sec. Max. Amps	Sec. Fuse Kit	Sec. Fuse Size
							D	E	F					
.050	HC-0050-47	50/60	3.0	5.00	3.00	3.25	2.25	2.50	.203 x .375	.21 / .10 / .08	FKP2	.42	Included	.5
.075	HC-0075-47	50/60	4.0	5.62	3.00	3.25	2.87	2.50	.203 x .375	.31 / .16 / .13	FKP2	.63	Included	.6
.100	HC-0100-47	50/60	5.5	5.25	3.75	3.75	2.50	3.12	.203 x .375	.42 / .21 / .17	FKP2	.83	Included	1
.150	HC-0150-47	50/60	7.5	6.12	3.75	3.75	3.31	3.12	.203 x .375	.63 / .31 / .25	FKP2	1.25	Included	1.25
.250	HC-0250-47	50/60	8.5	5.25	4.50	4.30	2.50	3.75	.203 x .375	1.0 / .52 / .42	FKP2	2.08	Included	2.25
.300	HC-0300-47	50/60	10.5	6.00	4.50	4.30	3.25	3.75	.203 x .375	1.25 / .63 / .50	FKP2	2.50	Included	2.5
.375	HC-0375-47	50/60	11.5	6.00	4.50	4.30	3.25	3.75	.203 x .375	1.6 / .78 / .63	FKP2	3.13	Included	3.2
.500	HC-0500-47	50/60	13.5	6.50	4.50	4.30	3.75	3.75	.203 x .375	2.1 / 1.0 / .83	FKP2	4.17	Included	4.5
.750	HC-0750-47	50/60	18.5	6.50	5.25	4.87	3.75	4.37	.203 x .375	3.1 / 1.6 / 1.3	FKP2	6.25	Included	6.25
1.0	HC-1000-47	60	20.0	6.75	5.25	4.87	4.00	4.37	.281 x .562	4.2 / 2.1 / 1.7	FKP2	8.33	Included	9
1.5	HC-1500-47	60	29.5	8.50	5.25	4.87	5.87	4.37	.281 x .562	6.3 / 3.1 / 2.5	FKP2	12.50	Included	15
2.0	HC-2000-47	60	32.0	8.50	4.25	6.25	5.93	3.43	.281 x .562	8.3 / 4.2 / 3.3	FKP2	16.67	Included	20

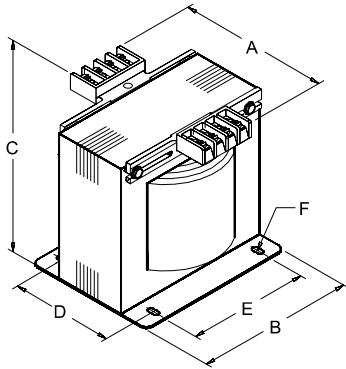

Outline Drawing  
HC Suffix -41,-44,-46,-47

Connection  
Diagrams may  
be found on  
Pg. 80

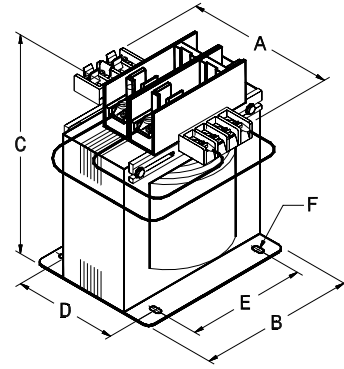

Outline Drawing  
HC Suffix -4100, -4400

## Series HC Primary Fuse Kit

### Fuse Kit FKP2

- Meets UL 508
- Meets NEC® Article 450
- Uses Class CC Fuses

#### Installation Procedure

- Locate the mounting hole in the terminal block of primary side of transformer.
- Fasten FKP2 fuse holder to primary side of transformer terminal block with the screw provided.
- Connect the fuse holder leads to the transformer terminals with the jumper leads furnished.

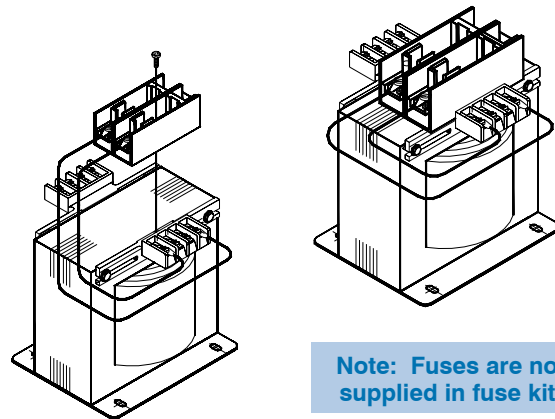

Note: Fuses are not  
supplied in fuse kit.

#### Series HC Recommended Fuse Type By Manufacturer

Manufacturer	Bussman	Gould	Littlefuse
Primary Fuse Type	FNQ-R	ATQR / ATDR	KLDR / CCRM
Secondary Fuse Type	FNM / FNQ (250V) (500V)	TRM / ATQ (250V) (500V)	FLM / FLQ (250V) (500V)



# Series HC Industrial Control Transformers

## Fuse Kit FKS

- Meets UL 508
- Meets NEC® Article 450
- Uses 13/32" x 1 1/2" Fuses

### Installation Procedure

- To fuse terminal X1, remove #10 screws in terminals X1, XF, and unmarked terminal slot.
- Fasten fuse clip to transformer terminal X1 using #10 screw.
- Fasten #10 screw through Fuse Clip, and Jumper Terminal and into unmarked terminal slot.
- Fasten #10 screw through Jumper Terminal and into terminal XF.
- Connect load to terminals X2 and XF.

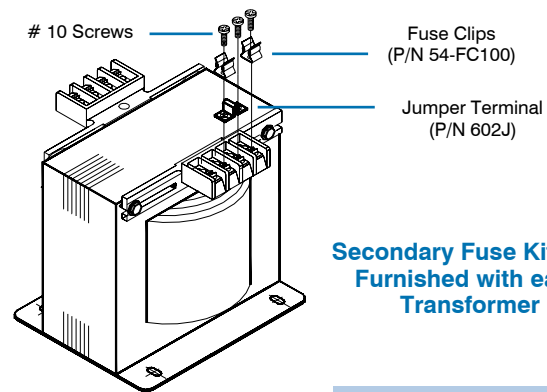

**Secondary Fuse Kit FKS  
Furnished with each  
Transformer**

**Note: Fuses are not  
supplied in fuse kit.**

## Series HC Connection Diagrams

Suffix -41				
Primary			Secondary	
Voltage	Jumper	Connect Incoming Lines To	Voltage	Connect Load To
240	H1 to H3 &	H1 & H4	120	X1 & X2
230			115	
220	H2 to H4		110	
480			120	X1 & X2
460	H2 to H3	H1 & H4	115	
440			110	

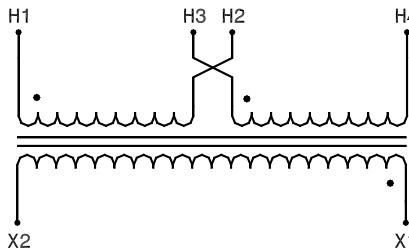

Suffix -4100				
Primary			Secondary	
Voltage	Jumper	Connect Incoming Lines To	Voltage	Connect Load To
240	H1 to H3 &	H1 & H4	120	XF & X2
230			115	
220	H2 to H4		110	
480			120	XF & X2
460	H2 to H3	H1 & H4	115	
440			110	

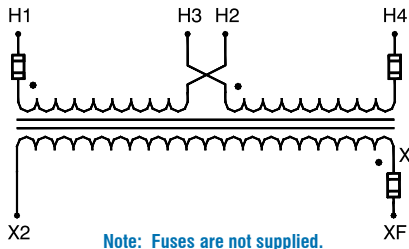

Suffix -44				
Primary			Secondary	
Voltage	Jumper	Connect Incoming Lines To	Voltage	Connect Load To
208	---	H1 & H2		X1 & X2
240	---	H1 & H3	120	
480	---	H1 & H4		

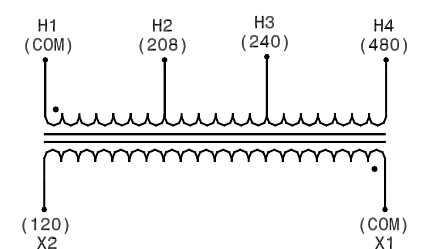

Suffix -4400				
Primary			Secondary	
Voltage	Jumper	Connect Incoming Lines To	Voltage	Connect Load To
208	---	H1 & H2		XF & X2
240	---	H1 & H3	120	
480	---	H1 & H4		

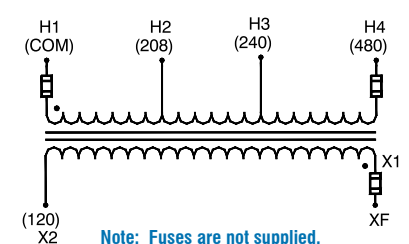

Suffix -46				
Primary			Secondary	
Voltage	Jumper	Connect Incoming Lines To	Voltage	Connect Load To
600	---	H1 & H2	120	X1 & X2

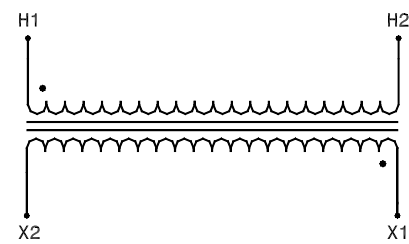

Suffix -47				
Primary			Secondary	
High Voltage	Jumper	Connect Incoming Lines To	Low Voltage	Connect Load To
240	---	H1 & H2		X1 & X2
480	---	H1 & H3	120	
600	---	H1 & H4		

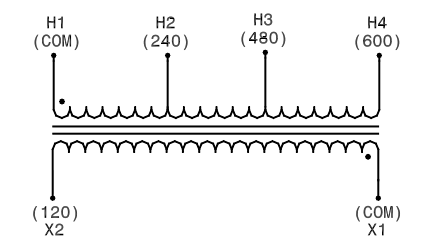

# Control Circuit Overcurrent Protection

Current North American Standards specify overcurrent protection on all control circuit transformers. These standards include the US National Electric Code®, UL 508, and the Canadian Electrical Code. Specified overcurrent protection may be accomplished by one of two options.

Primary Current (amps)	Overcurrent Protection Rating
Less than 2	300% maximum
2 to 9	167% maximum
9 or more	125% of rated primary current (or next higher standard rating)

Option 1: Provide primary overcurrent protection based on the parameters below.

Option 2: Provide both primary and secondary overcurrent protection. When this option is followed, the primary overcurrent device should be rated at no more than 250% of rated primary current and the secondary overcurrent device at no more than 125% of rated secondary current.

Option 2 is the preferred method of overcurrent protection, as it minimizes nuisance trips due to start-up inrush.

In either method, it is recommended that Class CC, time delay primary fuses be used in order to help prevent nuisance trips.

## Series 50 and Series HC Primary Fuse Size Table

Values listed in the table below are sized per option 1 above. Select the next higher fuse size if the fuse values shown do not correspond with standard fuse sizes. Dongan® recommends you refer to the current version of the National Electrical Code® and/or applicable local codes for further information on your specific application.

Fuse Size Table													
Primary Voltage													
kVA Cap.	120	208	230	240	277	380	416	440	460	480	550	575	600
.050	1.25	.8	.7	.7	.5	.4	.4	.3	.3	.3	.3	.3	.25
.075	1.8	1.0	1.0	1.0	.8	.6	.6	.5	.5	.4	.4	.4	.4
.100	2.5	1.5	1.25	1.25	1.0	.8	.8	.6	.6	.6	.6	.5	.5
.150	3.5	2.0	2.0	2.0	1.6	1.0	1.0	1.0	1.0	1.0	.8	.8	.8
.200	5.0	3.0	2.5	2.5	2.0	1.6	1.5	1.4	1.25	1.25	1.0	1.0	1.0
.250	3.5	3.5	3.2	3.2	2.5	2.0	1.8	1.6	1.6	1.5	1.25	1.25	1.25
.300	4.5	4.5	4.0	4.0	3.2	2.25	2.25	2.0	2.0	1.8	1.6	1.6	1.5
.375	5.6	5.6	5.0	4.5	4.0	3.0	2.8	2.5	2.5	2.25	2.0	2.0	1.8
.500	7.0	4.0	3.5	3.5	5.6	4.0	3.5	3.5	3.2	3.0	2.8	2.5	2.5
.750	12.0	6.0	5.5	5.0	4.5	5.0	5.6	5.0	5.0	4.5	4.0	3.5	4.0
1.0	15.0	8.0	7.5	7.0	6.0	4.5	4.0	4.0	3.5	3.5	5.0	5.0	5.0
1.5	17.5	12.0	12.0	12.0	9.0	6.25	6.0	5.6	5.0	5.0	4.5	4.0	4.0
2.0	25.0	15.0	15.0	15.0	12.0	9.0	8.0	7.5	7.0	7.0	6.0	6.0	6.0
3.0	30.0	20.0	17.5	17.5	15.0	15.0	12.0	12.0	12.0	10.0	9.0	9.0	8.0
5.0	---	30.0	30.0	30	25	20.0	20.0	15.0	15.0	15.0	12.0	15.0	15.0

# Series ES-10 CE Marked Industrial Control Transformers

Series ES Industrial Control Transformers are designed to comply with Domestic, North American, and European Union electrical and testing standards. Series ES are UL and Canadian UL Listed by Underwriters Labs. In addition, Series ES are CE Marked, and licensed by the German testing agency TÜV Rheinland under License Number R 9679035.01.

Series ES transformers are the answer to your export needs. With the voltage combinations listed below, and built in approvals, the ES Series provides no-nonsense solutions for control and automation equipment destined for the European Community of nations.

The voltage combinations offered represent some of the most universally used. However, any combination of primary and secondary incorporating voltages of 600 volts and below is available on a short lead time, special order basis. In addition, capacities up to 25 kVA and special temperature rise configurations can be furnished. Please consult your distributor, Dongan® Representative, or the factory for special ES Series transformer requirements.

## Features

### Agency Compliance



- All copper windings.
- IEC type finger safe terminals.
- 200°C Insulation System.
- 50/60 Hertz.
- Class 1, general use, isolating transformer.
- All Series ES are provided with an electrostatic shield (earth metal screen).
- All Series ES are provided with a color coded protective earth (PE) terminal.
- Consult factory for desired voltage combinations and kVA sizes not listed.

General Information											
Pri. Volts	380/400/416/440 460/480/575	380/416/480	380/400/416	220/380/400/416	Dimensions (inches)						Weight (lbs)
Sec. Volts	110/115/120	120/24 (24 Volts is limited to 20% of max. kVA)	110/220 115/230 120/240	95/115/120	A	B	C	Mounting			
kVA Cap.	Catalog Number	Catalog Number	Catalog Number	Catalog Number				D	E	F	
.150	ES-10100.326	ES-10100.366	ES-10100.376	ES-10100.386	4.00	4.50	5.31	2.75	3.75	.203 x .375	8
.250	ES-10130.326	ES-10130.366	ES-10130.376	ES-10130.386	5.25	4.50	6.31	3.25	3.75	.312 x .625	10
.375	ES-10150.326	ES-10150.366	ES-10150.376	ES-10150.386	6.00	4.50	6.31	4.50	3.75	.312 x .625	13
.500	ES-10170.326	ES-10170.366	ES-10170.376	ES-10170.386	5.25	5.25	6.88	3.25	4.38	.312 x .625	15
.750	ES-10190.326	ES-10190.366	ES-10190.376	ES-10190.386	6.00	6.38	7.81	4.00	5.31	.312 x .625	26
1.0	ES-10200.326	ES-10200.366	ES-10200.376	ES-10200.386	6.50	6.38	7.81	4.50	5.31	.312 x .625	30
1.5	ES-10210.326	ES-10210.366	ES-10210.376	ES-10210.386	6.00	7.50	8.81	4.00	6.00	.312 x .625	36
2.0	ES-10230.326	ES-10230.366	ES-10230.376	ES-10230.386	7.00	7.50	8.81	5.00	6.00	.312 x .625	50
3.0	ES-10250.326		ES-10250.376	ES-10250.386	8.00	7.50	8.88	6.00	6.00	.312 x .625	60
5.0	ES-10300.326		ES-10300.376	ES-10300.386	9.00	9.00	10.31	6.50	6.50	.312 x .625	90

### Series ES Single Phase and Three Phase Transformers

Please see Series ES - CE Marked Single Phase and Three Phase units in the appropriate sections of this catalog. A Certificate of Compliance is available by contacting your Dongan® Representative or the factory Customer Service Department.

**Dimensions & weights may change. Consult factory for certified drawings.**

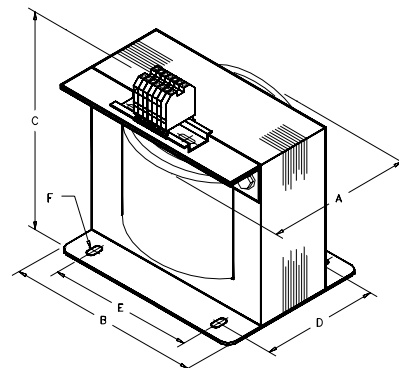

# Series ES-10 CE Marked Industrial Control Transformers

Suffix .326			
Primary Connections		Secondary Connections	
Pri. Voltage	Connect Incoming Lines To:	Sec. Voltage	Connect Load Lines To:
380	H1 & H3	110	X1 & X3
400	H1 & H3	115	X1 & X3
416	H1 & H4	115	X1 & X4
440	H1 & H4	120	X1 & X4
460	H1 & H4	115	X1 & X3
480	H1 & H4	120	X1 & X3
575	H1 & H5	120	X1 & X4

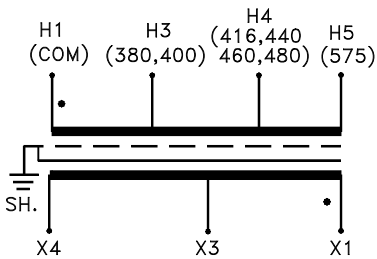

Suffix .366			
Primary Connections		Secondary Connections	
Pri. Voltage	Connect Incoming Lines To:	Sec. Voltage	Connect Load Lines To:
380	H1 & H3	24*	X1 & X3
416	H1 & H4	120	X1 & X4
480	H1 & H5		

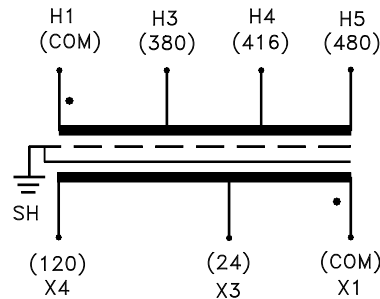

\*Maximum permissible load on 24 volt secondary is limited to 20% of the transformer's kVA. When 24 and 120 volts are used simultaneously, the total of both loads must not exceed the total transformer kVA.

Suffix .386			
Primary Connections		Secondary Connections	
Pri. Voltage	Connect Incoming Lines To:	Sec. Voltage	Connect Load Lines To:
220	H1 & H3	95	X1 & X3
380	H1 & H4	115	X1 & X4
400	H1 & H5	120	X1 & X5
416	H1 & H6		

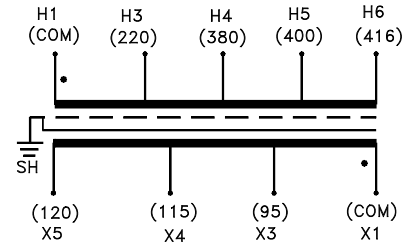

Suffix .376				
Primary Connections		Secondary Connections		
Pri. Voltage	Connect Incoming Lines To:	Sec. Voltage	Interconnect	Connect Load Lines To:
380	H1 & H2	110		X1 & X4
400	H1 & H2	115	X1 to X3 & X2 to X4	X1 & X4
416	H1 & H2	120		X1 & X4
380	H1 & H2	220		X1 & X4
400	H1 & H2	230	X2 to X3	X1 & X4
416	H1 & H2	240		X1 & X4
416	H1 & H2	120/240	X2 to X3	X1 & X2/X3 & X4

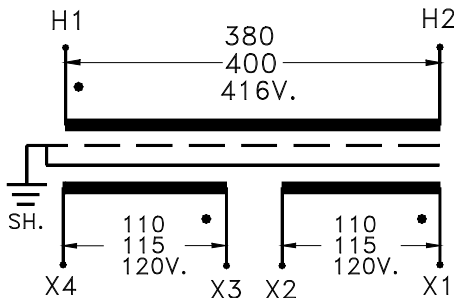

Series ES - 10\*

\*Style of terminals may vary depending on availability.

## Agency Compliance



# AP12 - Encapsulated Industrial Control Transformers

Series AP12 Industrial Control Transformers are designed to comply with industrial and automotive specifications that require the control transformer to be mounted in a separate enclosure, remote from the main control panel. Series AP12 control transformers eliminate the need to purchase a separate enclosure, as these units are encapsulated within a NEMA 12 enclosure suitable for remote mounting.

External or remote mounting of the Series AP12 conserves critical panel mounting space and reduces internal control cabinet temperatures, which can be critical to the reliable operation of many solid state, logic, and thermal control devices.

## Features



- All copper windings.
- NEMA 12 enclosure and encapsulated core

and coil construction.

- **180°C Insulation System and 55°C Temperature Rise** for long service in high ambient environments.
- **50/60 Hertz.**
- **Capacity range from 1 kVA to 10 kVA.**
- Available primary voltages include 208, 240, and 380, 480, 575, 600. Secondary voltage is 120 volts.
- Primary and secondary leads are equipped with ring terminals for convenient connections.
- **Regulation characteristics** equal or exceed the highest industry standards.
- **Electrostatic shield** available as an extra cost option.
- Consult factory for desired voltage combinations and kVA sizes not listed.

General Information											
Pri. Volts	240 X 480 230 X 460 220 X 440	380 / 575	208	600 575 550	Dimensions (Inches)						Weight (lbs)
Sec. Volts	120 115 110	120	120	120 115 110	Height A	Width B	Depth C	Depth D	Mounting		
kVA Cap.	Catalog Number	Catalog Number	Catalog Number	Catalog Number					EE	FF	
1.0	AP12-351	AP12-352	AP12-353	AP12-354	10.50	10.00	6.62	6.12	4.00	8.50	50
1.5	AP12-401	AP12-402	AP12-403	AP12-404	12.00	10.81	7.19	6.69	6.00	9.13	68
2.0	AP12-451	AP12-452	AP12-453	AP12-454	14.00	14.00	9.25	8.75	8.00	12.00	97
3.0	AP12-501	AP12-502	AP12-503	AP12-504	14.00	14.00	9.25	8.75	8.00	12.00	120
5.0	AP12-551	AP12-552	AP12-553	AP12-554	14.00	14.38	10.00	9.50	8.00	12.38	149
7.5	AP12-601	AP12-602	AP12-603	AP12-604	15.00	18.00	12.50	12.00	8.00	16.00	198
10.0	AP12-651	AP12-652	AP12-653	AP12-654	15.00	18.00	12.50	12.00	8.00	16.00	225

PRIMARY 240 x 480

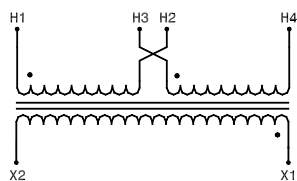

PRIMARY 600 or 208

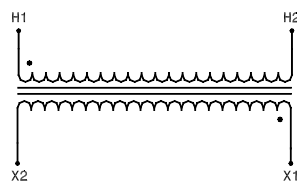

PRIMARY 380 / 575

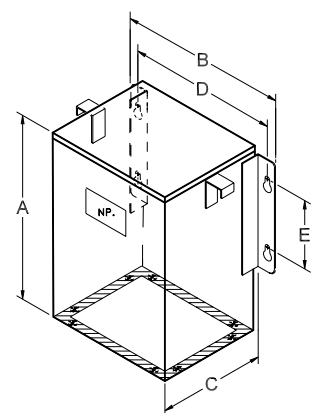
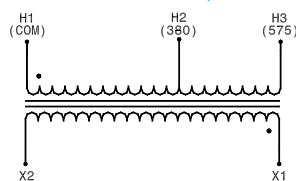

Dimensions & weights may change. Consult factory for certified drawings.

Series AP12  
Wall Mount - Encapsulated - NEMA 12

# Series FP12-Encapsulated Industrial Control Transformers

Series FP12 Industrial Control Transformers are similar to the AP12 Series with two important differences. The FP12 Series is 115°C rise (versus 55°C) and they are manufactured with an electrostatic shield between primary and secondary.

They are designed to comply with industrial and automotive specifications that require the control transformer to be mounted in a separate enclosure, remote from the main control panel.

External or remote mounting of the Series FP12 conserves critical panel mounting space and reduces internal control cabinet temperatures, which can be critical to the reliable operation of many solid state, logic, and thermal control devices.

and coil construction.

- **180°C Insulation System and 115°C Temperature Rise** for long service in high ambient environments.
- **Electrostatic Shield.**
- **60 Hz except 380/575-120 which is 50/60 Hz.**
- **50/60 Hz unit weights are approximately 20% higher than those shown.**
- **Primary and secondary leads** are equipped with ring terminals for convenient connections.
- **Regulation characteristics** equal or exceed the highest industry standards.
- Consult factory for desired voltage combinations and kVA sizes not listed.

## Features



- **All copper windings.**
- **NEMA 12 enclosure** and encapsulated core

General Information										
Pri. Volts	240 X 480 230 X 460 220 X 440	380 / 575	208	600 575 550	Dimensions (inches)					Weight (lbs)
Sec. Volts	120 115 110	120	120	120 115 110	Height A	Width B	Depth C	Mounting		
kVA Cap.	Catalog Number	Catalog Number	Catalog Number	Catalog Number				D	E	
1.0	FP12-351	FP12-352	FP12-353	FP12-354	10.50	10.00	6.62	6.12	4.00	29
1.5	FP12-401	FP12-402	FP12-403	FP12-404	10.50	10.00	6.62	6.12	4.00	38
2.0	FP12-451	FP12-452	FP12-453	FP12-454	12.00	10.81	7.19	6.69	6.00	45
3.0	FP12-501	FP12-502	FP12-503	FP12-504	12.00	10.81	7.19	6.69	6.00	78
5.0	FP12-551	FP12-552	FP12-553	FP12-554	14.00	14.00	9.25	8.75	8.00	97
7.5	FP12-601	FP12-602	FP12-603	FP12-604	14.00	14.38	10.00	9.50	8.00	151
10.0	FP12-651	FP12-652	FP12-653	FP12-654	14.00	14.38	10.00	9.50	8.00	164

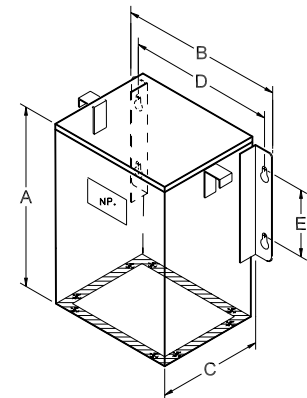
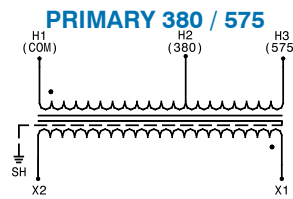
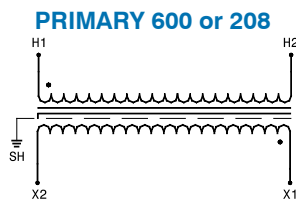
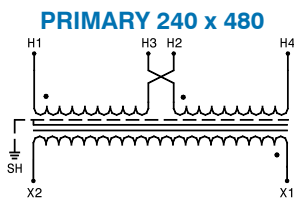

**Series FP12**  
Wall Mount - Encapsulated - NEMA 12

Dimensions & weights may change. Consult factory for certified drawings.