

ON OPTIMAL SOLUTION OF INTERVAL LINEAR EQUATIONS

Sergey P. Shary*

Abstract

For interval linear algebraic systems $\mathbf{A}x = \mathbf{b}$, the problem is considered of componentwise evaluation of the set $\Sigma_{\exists\exists}(\mathbf{A}, \mathbf{b}) = \{A^{-1}b \mid A \in \mathbf{A}, b \in \mathbf{b}\}$ formed by all solutions of $Ax = b$ when A and b vary independently in \mathbf{A} and \mathbf{b} , respectively. An iterative PSS algorithm is introduced that computes optimal (exact) componentwise estimates of $\Sigma_{\exists\exists}$ and its convergence is proved under fairly general conditions on the interval system. We introduce the concept of a *sequentially guaranteeing* algorithm, as a reasonable compromise between the requirements for the interval result to be guaranteed and to be obtained in a practically acceptable time.

KEY WORDS. Interval linear equations, outer problem, branch and bound method, sequentially guaranteeing algorithm.

AMS SUBJECT CLASSIFICATION. 65G10, 65H10.

Several interval problems are well known that naturally generalize the familiar linear algebraic system

$$Ax = b. \tag{1}$$

All of them are usually denoted by one formal notation

$$\mathbf{A}x = \mathbf{b}, \tag{2}$$

an interval linear algebraic system (ILAS) with interval $m \times n$ -matrix $\mathbf{A} \ni A$ and interval right-hand side m -vector $\mathbf{b} \ni b$, though the sense which is meant by this may be quite varied. For example, for the system (2), a *tolerable solution set*

$$\Sigma_{\forall\exists}(\mathbf{A}, \mathbf{b}) = \{x \in \mathbb{R}^n \mid (\forall A \in \mathbf{A})(\exists b \in \mathbf{b})(Ax = b)\}$$

exists, first considered in [20], as well as a *controllable solution set*

$$\Sigma_{\exists\forall}(\mathbf{A}, \mathbf{b}) = \{x \in \mathbb{R}^n \mid (\forall b \in \mathbf{b})(\exists A \in \mathbf{A})(Ax = b)\},$$

recently introduced in [14, 31]. But the most popular and historically first of these generalizations is the problem of finding “outer” componentwise estimates for the *united solution set*

$$\Sigma_{\exists\exists}(\mathbf{A}, \mathbf{b}) = \Sigma_{\exists\exists} = \{x \in \mathbb{R}^n \mid (\exists A \in \mathbf{A})(\exists b \in \mathbf{b})(Ax = b)\},$$

*Institute of computational technologies of Siberian Department of Russian Academy of Sciences, Lavrentiev ave., 6, 630090 Novosibirsk, Russia (shary@ict.nsc.ru). This work was partially supported by Krasnoyarsk Regional Science Foundation, Krasnoyarsk, Russia, under grant 1F0155.

the solution set of all real linear algebraic systems contained in (2). This problem is often formulated as follows:

Find an interval vector \mathbf{V} that contains
the united solution set of the given ILAS. (3)

If the components of \mathbf{V} have the least possible length, i.e., coincide with the projections of $\Sigma_{\exists\exists}$ on the coordinate axes, then \mathbf{V} is called the *optimal interval solution* of the problem (3) and the corresponding componentwise estimates of $\Sigma_{\exists\exists}$ are called *optimal*. When referring to this problem one sometimes speaks of *solving interval linear algebraic systems* [1, 17, 18] or even *solving interval linear equations* [7, 27]. To my mind, the Russian term *outer problem for interval linear algebraic system* is more suitable for this case.

A large number of papers are devoted to the problem (3); see for example [1, 3, 7, 8, 9, 11, 17, 18, 19, 21, 22, 27, 28] and the extensive references there. All the algorithms so far devised compute an interval vector \mathbf{V} guaranteed to contain the set $\Sigma_{\exists\exists}$, but only few of them ensure optimality of \mathbf{V} in general, the enormous labor consumption of such algorithms not being even their main disadvantage. The purpose of this work is to advance yet another, promising computational procedure — a *PSS algorithm* — to compute optimal solutions of interval linear systems (i.e., of the problem (3)), to demonstrate its efficacy, and discuss its advantages and shortcomings.

The plan of the paper is as follows. Section 1 presents necessary notation, reviews some facts of interval analysis, and states the problem. Section 2 is devoted to the construction proper of the simplest PSS algorithm, and §3 gives a proof of its convergence to optimal estimates of the united solution set. In §4 the basic algorithm is improved to incorporate accuracy control and to save storage. Section 5 discusses results of numerical experiments with the PSS algorithm. Of separate interest is the parametric family of interval linear systems proposed in §5, which may be recommended as test problems for algorithms solving the outer problem. Also, we substantiate the empirical conclusion that the complexity of the PSS algorithm is exponential as a function of the dimensional of the system in the worst case. Finally, §6 contains thorough comparison of the PSS algorithm with the other existing computational approaches to finding optimal solutions of the outer problem. In particular, we introduce the concept of a *sequentially guaranteeing* algorithm, as a reasonable compromise between the requirements for the interval result to be guaranteed and to be obtained in a practically acceptable time.

A good many of the results stated below were first published in abridged form in [29]. The author is grateful to Prof. Vyacheslav Novikov for his critical comments on this work and to the referees for their valuable suggestions.

1 Notation, conventions and problem statement

Let $\mathbb{IR} =$ the set of all real intervals $[a; b]$ on \mathbb{R} , $a \leq b$,

$\mathbb{IR}^n =$ the set of n -dimensional interval vectors.

In this paper intervals and other interval objects are denoted by boldface letters while non-interval (real) objects are not distinguished in any way. Also, we need the following notation

$\bar{\mathbf{a}}, \underline{\mathbf{a}}$ — upper and lower bounds of \mathbf{a} , respectively,

$\text{mid } \mathbf{a} = (\bar{\mathbf{a}} + \underline{\mathbf{a}})/2$ — mean value (midpoint) of \mathbf{a} ,

$\text{rad } \mathbf{a} = (\bar{\mathbf{a}} - \underline{\mathbf{a}})/2$ — radius of \mathbf{a} ,

$|\mathbf{a}| = \max\{|\bar{\mathbf{a}}|, |\underline{\mathbf{a}}|\}$ — absolute value (magnitude) of \mathbf{a} ,

$$\langle \mathbf{a} \rangle = \begin{cases} \min\{|\bar{\mathbf{a}}|, |\underline{\mathbf{a}}|\}, & \text{if } 0 \notin \mathbf{a}, \\ 0, & \text{otherwise} \end{cases} \quad \text{— magnitude of } \mathbf{a} \text{ or the least distance between points of } \mathbf{a} \text{ and zero, in some sense the opposite of the absolute value.}$$

If $\mathbf{a} = (\mathbf{a}_i)_{i=1}^n$ is an interval vector, then all of the operations defined above are to be understood componentwise, so that $\text{rad } \mathbf{a}$, for instance, is the real vector $(\text{rad } \mathbf{a}_i)_{i=1}^n$. By $\|\cdot\|$ we designate some monotonic vector norm.

Throughout the rest of this paper, all arithmetic operations with intervals and interval objects are those of classical interval arithmetic [1, 16, 18] except for division by a zero-containing interval, where we will make use of the extended Kahan arithmetic [15]. Besides common intervals of \mathbb{R} its elements are sets of the form $(-\infty; p] \cup [q; +\infty)$, $p \leq q$, and $(-\infty; p]$, $[q; +\infty)$. We allow the equalities $p = -\infty$ and $q = +\infty$, so that the former of these sets includes the latter ones. Results of the division \mathbf{a}/\mathbf{b} , $0 \notin \mathbf{b}$, and of all other operations on objects from \mathbb{IR} are the same both in classical and in Kahan interval arithmetics. For convenience, we write results concerning the division \mathbf{a}/\mathbf{b} , $0 \in \mathbf{b}$, in detailed form:

1. $\mathbf{b} = 0$.
 If $0 \in \mathbf{a}$, then $\mathbf{a}/\mathbf{b} = \mathbb{R}$ — the whole real axis, and
 if $0 \notin \mathbf{a}$, then $\mathbf{a}/\mathbf{b} = \emptyset$.
2. $\mathbf{b} \neq 0$.
 - (a) Let zero be one of the endpoints of \mathbf{b} .
 If $0 \notin \mathbf{a}$, then
 $\mathbf{a}/\mathbf{b} = (-\infty; -\langle \mathbf{a} \rangle / |\mathbf{b}|]$ when $\bar{\mathbf{a}} < 0 \leq \underline{\mathbf{b}}$ or $\bar{\mathbf{b}} \leq 0 < \underline{\mathbf{a}}$,
 and
 $\mathbf{a}/\mathbf{b} = [\langle \mathbf{a} \rangle / |\mathbf{b}|; +\infty)$ when both \mathbf{a} and \mathbf{b} are nonnegative or nonpositive intervals.
 If $0 \in \mathbf{a}$, then $\mathbf{a}/\mathbf{b} = \mathbb{R}$.
 - (b) Let $\underline{\mathbf{b}} < 0 < \bar{\mathbf{b}}$.
 If $\mathbf{a} > 0$, then $\mathbf{a}/\mathbf{b} = (-\infty; \langle \mathbf{a} \rangle / \underline{\mathbf{b}}] \cup [\langle \mathbf{a} \rangle / \bar{\mathbf{b}}; +\infty)$
 and
 if $\mathbf{a} < 0$, then $\mathbf{a}/\mathbf{b} = (-\infty; -\langle \mathbf{a} \rangle / \bar{\mathbf{b}}] \cup [-\langle \mathbf{a} \rangle / \underline{\mathbf{b}}; +\infty)$.
 If $0 \in \mathbf{a}$ the set \mathbf{a}/\mathbf{b} is the union $(-\infty; 0] \cup [0; +\infty)$, i.e., coincides with all of \mathbb{R} .

It is worthwhile to note that in the Kahan arithmetic the fundamental property

$$\mathbf{a} \circ \mathbf{b} = \{ a \circ b \mid a \in \mathbf{a}, b \in \mathbf{b} \} \quad \text{for } \circ \in \{ +, -, \cdot, / \}$$

holds (which is the basis of the classical interval arithmetic too) as well as inclusion monotonicity.

Let \mathbf{A} be an interval $m \times n$ -matrix and $\mathbf{b} \in \mathbb{IR}^m$. As was already noted, the united solution set of the interval linear algebraic system (2) is

$$\Sigma_{\exists\exists}(\mathbf{A}, \mathbf{b}) = \Sigma_{\exists\exists} = \{ x \in \mathbb{R}^n \mid (\exists A \in \mathbf{A})(\exists b \in \mathbf{b})(Ax = b) \},$$

and the problem that concerns us is that of computing the most accurate “outer” componentwise estimates for this set, i.e., the problem of evaluating $\min\{x_\nu \mid x \in \Sigma_{\exists\exists}\}$ from below and $\max\{x_\nu \mid x \in \Sigma_{\exists\exists}\}$ from above, $\nu = 1, 2, \dots, n$. In what follows, our attention will be focused on finding $\min\{x_\nu \mid x \in \Sigma_{\exists\exists}\}$ for arbitrary but everywhere below fixed index ν , because

$$\max\{x_\nu \mid x \in \Sigma_{\exists\exists}(\mathbf{A}, \mathbf{b})\} = -\min\{x_\nu \mid x \in \Sigma_{\exists\exists}(\mathbf{A}, -\mathbf{b})\}.$$

Since throughout this paper we deal only with the united solution set of the interval system (2), let us denote for brevity

$$\Sigma = \Sigma_{\exists\exists}(\mathbf{A}, \mathbf{b})$$

and speak simply of the *solution set* instead of the expanded term “united solution set”. Also, we shall assume that some initial approximation interval vector $\mathbf{V} \supseteq \Sigma$ is already known. It may be found by any of the algorithms presented in [1, 7, 17, 18, 28], and its size does not matter essentially in the sequel, though, of course, the choice of more “narrow” initial approximation favors faster convergence of the algorithm developed.

In interval analysis \mathbf{A} is usually assumed to be square non-singular, that is, to contain non-singular point matrices only in order to ensure boundedness of the solution set. We shall not restrict our considerations to this condition and allow the possibility that \mathbf{A} is rectangular, but in case the solution set is unbounded the problem statement should be slightly changed. Namely, it is then expedient to consider that the set $\Sigma_{\exists\exists}(\mathbf{A}, \mathbf{b})$ is the intersection of the whole united solution set with some interval vector \mathbf{U} given beforehand. It would appear natural that $\mathbf{V} = \mathbf{U}$ without loss in generality.

2 Basic algorithm

Let l be a straight line in \mathbb{R}^n with parametric equation

$$\left\{ \begin{array}{l} x_1 = r_1, \\ \vdots \\ x_{\nu-1} = r_{\nu-1}, \\ x_\nu = t, \\ x_{\nu+1} = r_{\nu+1}, \\ \vdots \\ x_n = r_n \end{array} \right. \quad (t \in \mathbb{R} \text{ — parameter}), \tag{4}$$

parallel to the ν th coordinate axis. Each such line is defined completely by the $(n-1)$ -dimensional real vector $r = (r_1, \dots, r_{\nu-1}, r_{\nu+1}, \dots, r_n)^\top$, and to indicate these line parameters explicitly we will sometimes denote the line as $l(r)$. Let also

$$\Omega(r) = \min\{x_\nu \mid x \in \Sigma \cap l(r)\}$$

be the least ν th coordinate value of points from intersection of $l(r)$ with the solution set of ILAS (2) (if $\Sigma \cap l(r) = \emptyset$, then set $\Omega(r) = +\infty$). How are the function values $\Omega(r)$ computed?

To answer this question we “substitute” the parametric equation (4) into the ILAS (2), which then turns into a system of m linear equations with only one variable t and interval coefficients:

$$\left\{ \begin{array}{l} \mathbf{a}_{1\nu}t + \sum_{j=1, j \neq \nu}^n \mathbf{a}_{1j}r_j = \mathbf{b}_1, \\ \vdots \\ \mathbf{a}_{m\nu}t + \sum_{j=1, j \neq \nu}^n \mathbf{a}_{mj}r_j = \mathbf{b}_m, \end{array} \right. \tag{5}$$

or in matrix form

$$\mathbf{A}_\nu t + \tilde{\mathbf{A}}r = \mathbf{b}, \tag{6}$$

where $\mathbf{A}_\nu =$ the ν th column of \mathbf{A} ,

$\tilde{\mathbf{A}} =$ the interval $m \times (n-1)$ -matrix obtained from \mathbf{A} by removing its ν th column.

The essence of this procedure is as follows. When substituting the parametric equation (4) into the point system (1), we get a system of m one-dimensional equations that coincides with (5) in structure, but has real coefficients. Then vary the elements a_{ij} of the matrix and the elements b_i of the vector within the prescribed bounds \mathbf{a}_{ij} and \mathbf{b}_i , respectively. Clearly the set of all point systems so obtained forms exactly (5)–(6).

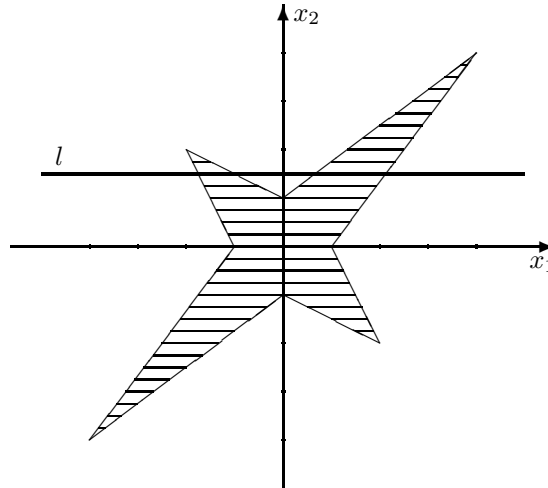

Figure 1: The solution set to (9).

It is easily seen that the solution of the i th equations of this system is the set

$$\left(\mathbf{b}_i - \sum_{j=1, j \neq \nu}^n \mathbf{a}_{ij} r_j \right) / \mathbf{a}_{i\nu}, \tag{7}$$

where “/” is, in general, the Kahan arithmetic division. Having solved separately each of one-dimensional interval linear equations belonging to the system (5), intersect their solution sets (7) with each other and with \mathbf{V}_ν . Since within all of the intervals entering into (5) the respective coefficients are varying independently from each other (as in the initial ILAS), the set we have thus gotten gives ν th coordinate values of points from $\Sigma \cap l$. Note that it may prove to be empty if the system (5) is incompatible, or disconnected (as shown in Fig. 1) if some of equations from (5) have solutions $(-\infty; p] \cup [q; +\infty)$, $p < q$.

For the rest of this paper, the fact of fundamental importance is that of reformulating the outer problem for interval linear algebraic system as an optimization problem —

$$\begin{aligned} & \min\{ x_\nu \mid x \in \Sigma \} \\ &= \min\left\{ x_\nu \mid x \in \bigcup_{l \cap \mathbf{V} \neq \emptyset} (\Sigma \cap l) \right\} \\ &= \min\left\{ \min\{ x_\nu \mid x \in \Sigma \cap l(r) \} \mid r \in (\mathbf{V}_1, \dots, \mathbf{V}_{\nu-1}, \mathbf{V}_{\nu+1}, \dots, \mathbf{V}_n) \right\} \\ &= \min\{ \Omega(r) \mid r \in (\mathbf{V}_1, \dots, \mathbf{V}_{\nu-1}, \mathbf{V}_{\nu+1}, \dots, \mathbf{V}_n) \}, \end{aligned} \tag{8}$$

i.e., as a problem of minimizing the objective function $\Omega(r)$ on some finite-dimensional compact set. We have already seen how to compute the values $\Omega(r)$, and so one would think that the outer problem may be solved successfully by any of the well known global optimization algorithms. The objective

function $\Omega(r)$, however, has a disagreeable distinction: it is not even continuous in general. Given, for instance, the interval system

$$\begin{pmatrix} [1; 2] & [-\frac{3}{4}; \frac{1}{2}] \\ [-\frac{3}{4}; \frac{1}{2}] & [1; 2] \end{pmatrix} x = \begin{pmatrix} [-1; 1] \\ [-1; 1] \end{pmatrix}, \tag{9}$$

(its solution set $\bar{\Sigma}$ is represented in Fig. 1), we have $r = x_2$ and

$$\lim_{r \rightarrow 2-0} \Omega(r) = -2 \neq 4/3 = \lim_{r \rightarrow 2+0} \Omega(r)$$

when estimating $\min\{x_1 \mid x \in \bar{\Sigma}\}$. Furthermore, $\Omega(r)$ undergoes discontinuities of the second kind (to $+\infty$).

These circumstances crucially limit the range of global optimization algorithms applicable to the problem (8). Currently popular nonuniform covering methods from [4] and [24] are obviously unfit for solving (8), because they substantially exploit Lipschitz continuity of the objective function.

Nevertheless, we shall demonstrate that the outer problem can be solved by a sequential deterministic algorithm based on branch-and-bound techniques. In interval mathematics since the pioneering work of Skelboe [32], this kind of method has been developed extensively by Asaithambi, Shen Zuhe and Moore [2], Hansen [10], Ratschek [25], Ratschek and Rokne [26], Jansson [12] and many others. We need only to construct effective ways to compute a domain minorant for $\Omega(r)$ (its inclusion function's left endpoint).

To put it another way, for any $\mathbf{r} = (\mathbf{r}_1, \dots, \mathbf{r}_{\nu-1}, \mathbf{r}_{\nu+1}, \dots, \mathbf{r}_n)^\top \in \mathbb{I}\mathbb{R}^{n-1}$ we have to evaluate

$$\min\{ \Omega(r) \mid r \in \mathbf{r} \} = \min \left\{ \bigcup_{r \in \mathbf{r}} \{ x_\nu \mid x \in \Sigma \cap l(r) \} \right\} \tag{10}$$

from below. The simplest way of doing this is as follows. We proceed with the initial interval system (2) just the same as in the case of determining $\Sigma \cap l$, but now the intervals $\mathbf{r}_1, \dots, \mathbf{r}_{\nu-1}, \mathbf{r}_{\nu+1}, \dots, \mathbf{r}_n$ are substituted for $x_1, \dots, x_{\nu-1}, x_{\nu+1}, \dots, x_n$ in (2) rather than real numbers $r_1, \dots, r_{\nu-1}, r_{\nu+1}, \dots, r_n$. Then, as before, we shall compute the intersection \mathcal{S} of all the solution sets to m one-dimensional interval equations making up the system

$$\begin{cases} \mathbf{a}_{1\nu}t + \sum_{j=1, j \neq \nu}^n \mathbf{a}_{1j}\mathbf{r}_j = \mathbf{b}_1, \\ \vdots \\ \mathbf{a}_{m\nu}t + \sum_{j=1, j \neq \nu}^n \mathbf{a}_{mj}\mathbf{r}_j = \mathbf{b}_m, \end{cases} \tag{11}$$

or

$$\mathbf{A}_\nu t + \tilde{\mathbf{A}}\mathbf{r} = \mathbf{b}$$

in the notation of (6). It is now fairly simple to realize that

$$\mathcal{S} \supseteq \bigcup_{r \in \mathbf{r}} \{ x_\nu \mid x \in \Sigma \cap l(r) \}$$

inasmuch as

$$\left\{ \begin{array}{l} \text{the solution set} \\ \text{of } \mathbf{A}_\nu t + \tilde{\mathbf{A}} r = \mathbf{b} \end{array} \right\} \subseteq \left\{ \begin{array}{l} \text{the solution set} \\ \text{of } \mathbf{A}_\nu t + \tilde{\mathbf{A}} \mathbf{r} = \mathbf{b} \end{array} \right\}$$

for all $r \in \mathbf{r}$. Therefore

$$\Omega(\mathbf{r}) = \min\{ \mathcal{S} \cap \mathbf{V}_\nu \} \tag{12}$$

gives the required low estimate for (10) (cf. the operator Γ in [18]). If the system (11) is incompatible for some \mathbf{r} (that corresponds to $\Sigma \cap l(r) = \emptyset$ for all $r \in \mathbf{r}$), then put $\Omega(\mathbf{r}) = +\infty$.

We utilize the notation $\Omega(\mathbf{r})$ to emphasize that the procedure we have implemented is actually a *natural interval extension* of $\Omega(r)$ [16]. We may even consider a function $\Omega : \mathcal{V} \rightarrow \mathbb{R}$ to be defined, with range in the semi-extended real axis $\mathbb{R} = \mathbb{R} \cup \{+\infty\}$, and with the set

$$\mathcal{V} = \{ \mathbf{r} \in \mathbb{R}^{n-1} \mid \mathbf{r} \subseteq (\mathbf{V}_1, \dots, \mathbf{V}_{\nu-1}, \mathbf{V}_{\nu+1}, \dots, \mathbf{V}_n) \}$$

as its domain. It is worthwhile to note that $\Omega(\mathbf{r}') \geq \Omega(\mathbf{r}'')$ for $\mathbf{r}' \subseteq \mathbf{r}''$, and evaluating (10) through $\Omega(\mathbf{r})$ becomes increasingly precise as the vector \mathbf{r} becomes thinner, i.e., as $\|\text{rad } \mathbf{r}\|$ becomes smaller, provided some natural restrictions on \mathbf{A} , \mathbf{b} , \mathbf{V} , \mathbf{r} are imposed. This assertion will be discussed at length in §3.

Finally, we are ready to construct our algorithm for determining $\min\{x_\nu \mid x \in \Sigma\}$. This is an iterative procedure for successively refining this low value estimate designed in accordance with the well known “branch and bound method” strategy, similar to what has been done for optimization problems in [2, 5, 10, 12, 24, 25, 26, 32] and other works. Here, bisections of the initial $(n-1)$ -dimensional box $(\mathbf{V}_1, \dots, \mathbf{V}_{\nu-1}, \mathbf{V}_{\nu+1}, \dots, \mathbf{V}_n)$ (it contains all point vectors r corresponding to lines $l(r)$ that have nonempty intersection with Σ) to thinner ones \mathbf{P} , amount to “branches”, while computing $\Omega(\mathbf{P})$ — ν th coordinate estimates of points from $\{\Sigma \cap l(r) \mid r \in \mathbf{P}\}$ — stands for finding “bounds”.

The algorithm generates an ordered list L consisting of pairs

$$(\mathbf{P}, \Omega(\mathbf{P})),$$

$\mathbf{P} \subseteq (\mathbf{V}_1, \dots, \mathbf{V}_{\nu-1}, \mathbf{V}_{\nu+1}, \dots, \mathbf{V}_n)$, so that the second members of all pairs increase. The first pair $(\mathbf{Q}, \Omega(\mathbf{Q}))$ of the list L is of special importance in our consideration. We will call it, as well as the related box \mathbf{Q} and estimate $\Omega(\mathbf{Q})$, the *leading* one. At the start of the algorithm the list L contains the single pair $((\mathbf{V}_1, \dots, \mathbf{V}_{\nu-1}, \mathbf{V}_{\nu+1}, \dots, \mathbf{V}_n), \underline{\mathbf{V}}_\nu)$. The following sequence of steps is then carried out, each divided into several stages:

1. In the leading box \mathbf{Q} , choose the largest component \mathbf{Q}_ι , i.e. such one that

$$\text{rad } \mathbf{Q}_\iota = \max_{1 \leq i \leq n} \text{rad } \mathbf{Q}_i.$$

If several components of \mathbf{Q} have maximum width, then ι is the index of any one of these.

2. Bisect the leading box \mathbf{Q} in the component ι to get descendants

$$\begin{aligned} \mathbf{Q}' &= (\mathbf{Q}_1, \dots, \mathbf{Q}_{\iota-1}, [\underline{\mathbf{Q}}_\iota; \text{mid } \mathbf{Q}_\iota], \mathbf{Q}_{\iota+1}, \dots, \mathbf{Q}_n), \\ \mathbf{Q}'' &= (\mathbf{Q}_1, \dots, \mathbf{Q}_{\iota-1}, [\text{mid } \mathbf{Q}_\iota; \overline{\mathbf{Q}}_\iota], \mathbf{Q}_{\iota+1}, \dots, \mathbf{Q}_n), \end{aligned}$$

3. Compute $\Omega(\mathbf{Q}')$ and $\Omega(\mathbf{Q}'')$.
4. Remove the late leading pair $(\mathbf{Q}, \Omega(\mathbf{Q}))$ from the list L .
5. Insert the new pairs $(\mathbf{Q}', \Omega(\mathbf{Q}'))$ and $(\mathbf{Q}'', \Omega(\mathbf{Q}''))$ into L in the proper order (of increasing second member).

Thus, executing the algorithm yields a non-decreasing sequence (beginning with the second step) of leading estimates which is shown in [25] to approximate the required $\min\{x_\nu \mid x \in \Sigma\}$ from below. In the next section we prove that this sequence converges to the exact value of $\min\{x_\nu \mid x \in \Sigma\}$. We shall refer to this class of algorithms to solve the outer problem for interval algebraic equations, based on *adaptive Partitioning of the Solution Set*, as *PSS algorithms*.

3 Convergence proof

The proof of the convergence of the simplest PSS algorithms, as distinct from [2, 10, 32], is not trivial because the objective function $\Omega(r)$ is not continuous in general. For discontinuous objective function, global optimization algorithms of this type had already been investigated by Evtushenko and Rat'kin [5] and Ratschek [25], however, the convergence criteria obtained by them are hardly applicable directly to our situation.

Let E be a topological space. Remember that the function $f : E \rightarrow \mathbb{R}$ is said to be lower semicontinuous at $y \in E$ if $f(y) = \underline{\lim}_{x \rightarrow y} f(x)$. The function is called lower semicontinuous in E if it is lower semicontinuous at any point of E . The equivalent definition of this property is as follows [33]: $f : E \rightarrow \mathbb{R}$ is lower semicontinuous iff for any $c \in \mathbb{R}$ the Lebesgue set $\{f(x) \leq c\}$ is closed in E .

Lemma 1 *Let the interval linear algebraic system $\mathbf{A}\mathbf{x} = \mathbf{b}$ and interval vector $\mathbf{V} \supseteq \Sigma$ be such that*

$$(NZ) \left\{ \begin{array}{l} \text{for each } i = 1, 2, \dots, m, \text{ the following condition holds:} \\ \quad \text{zero is not an endpoint of } \mathbf{a}_{i\nu} \\ \quad \text{or} \\ \text{for each } \mathbf{r} \subseteq (\mathbf{V}_1, \dots, \mathbf{V}_{\nu-1}, \mathbf{V}_{\nu+1}, \dots, \mathbf{V}_n) \\ \quad \text{zero is not an endpoint of the interval} \\ \quad \left(\mathbf{b}_i - \sum_{j=1, j \neq \nu}^n \mathbf{a}_{ij} \mathbf{r}_j \right). \end{array} \right.$$

Then the function $\Omega : \mathbb{R}^{n-1} \supseteq \mathcal{V} \rightarrow \mathbb{R}$ defined by (12) is lower semicontinuous.

Proof. Let \mathcal{B} denote the set of all $i \in \{0, 1, 2, \dots, m\}$ for which $0 \notin \mathbf{a}_{i\nu}$, the solution sets of the respective equations from (11) being *bounded* intervals $[\underline{t}_i; \bar{t}_i]$. In doing this, we assume $\underline{t}_0 = \underline{\mathbf{V}}_\nu$ and $\bar{t}_0 = \bar{\mathbf{V}}_\nu$ for the sake of convenience, so that \mathcal{B} is always nonempty. Also denote $\mathcal{U} = \{0, 1, 2, \dots, m\} \setminus \mathcal{B}$, and let $(-\infty; \underline{t}_i] \cup [\bar{t}_i; +\infty)$ for $i \in \mathcal{U}$ represent *unbounded* solution sets of equations from (11) with $0 \in \mathbf{a}_{i\nu}$, supposed to have $\underline{t}_i = -\infty$ or $\bar{t}_i = +\infty$ when the respective solution set is a ray in \mathbb{R} , and $\underline{t}_i = \bar{t}_i = 0$ when the solution set coincides with all of \mathbb{R} .

In interval spaces the standard topology is set by the Hausdorff metric, and all interval arithmetic operations are continuous relative to it [1, 16, 18]. Hence, \underline{t}_i and \bar{t}_i , $i \in \mathcal{B}$, are continuous functions of $(\mathbf{r}_1, \dots, \mathbf{r}_{\nu-1}, \mathbf{r}_{\nu+1}, \dots, \mathbf{r}_n)^\top$ from (11). But when $0 \in \mathbf{a}_{i\nu}$, the real numbers \underline{t}_i and \bar{t}_i defining the solution set of the one-dimensional equation

$$\mathbf{a}_{i\nu} t + \sum_{j=1, j \neq \nu}^n \mathbf{a}_{ij} \mathbf{r}_j = \mathbf{b}_i,$$

also depend continuously on interval vector $\mathbf{r} = (\mathbf{r}_1, \dots, \mathbf{r}_{\nu-1}, \mathbf{r}_{\nu+1}, \dots, \mathbf{r}_n)^\top$, if $\underline{\mathbf{a}}_{i\nu} < 0 < \bar{\mathbf{a}}_{i\nu}$ or if $(\mathbf{b}_i - \sum_{j \neq \nu}^n \mathbf{a}_{ij} \mathbf{r}_j)$ never has zero as one of its endpoints. This follows from (7) and the formulae of Section 1 and is ensured by the condition (NZ) of the Lemma 1. We may therefore assume in the sequel that the values $\max_{i \in \mathcal{B}} \underline{t}_i$, $\min_{i \in \mathcal{B}} \bar{t}_i$, $\max_{i \in \mathcal{U}} \bar{t}_i$, $\min_{i \in \mathcal{U}} \underline{t}_i$ are continuous functions of the vector \mathbf{r} from (11) (as usual $\min \emptyset = +\infty$, $\max \emptyset = -\infty$).

Next we shall prove that the effective domain of the function $\Omega(\mathbf{r})$, i.e., the set $\text{dom } \Omega = \{\mathbf{r} \in \mathcal{V} \subset \mathbb{R}^{n-1} \mid \Omega(\mathbf{r}) < +\infty\}$, is compact. A vector \mathbf{r} belonging to $\text{dom } \Omega$ means the compatibility of the corresponding system (11). Then, first, the intersection $\bigcap_{i \in \mathcal{B}} [\underline{t}_i; \bar{t}_i]$ of all bounded solutions of equations from (11) is nonempty. It is equivalent to $\min_{i \in \mathcal{B}} \bar{t}_i \geq \max_{i \in \mathcal{B}} \underline{t}_i$. Second, $\bigcap_{i \in \mathcal{B}} [\underline{t}_i; \bar{t}_i]$ has nonempty intersection with the unbounded solutions $(-\infty; \underline{t}_i] \cup [\bar{t}_i; +\infty)$, $i \in \mathcal{U}$, of one-dimensional equations of the system (11). The latter is equivalent to

$$\left(\min_{i \in \mathcal{U}} \underline{t}_i \geq \max_{i \in \mathcal{B}} \underline{t}_i \right) \vee \left(\max_{i \in \mathcal{U}} \bar{t}_i \leq \min_{i \in \mathcal{B}} \bar{t}_i \right),$$

\vee being a logical disjunction. Overall, $\text{dom } \Omega$ is described by the condition

$$\min \left\{ \min_{i \in \mathcal{B}} \bar{t}_i - \max_{i \in \mathcal{B}} \underline{t}_i, \max \left\{ \min_{i \in \mathcal{U}} \underline{t}_i - \max_{i \in \mathcal{B}} \underline{t}_i, \min_{i \in \mathcal{B}} \bar{t}_i - \max_{i \in \mathcal{U}} \bar{t}_i \right\} \right\} \geq 0.$$

As long as the function in the left-hand side of this inequality is continuous with respect to \mathbf{r} , we have thus proved that $\text{dom } \Omega$ is closed. Obviously $\text{dom } \Omega$ is bounded as well, so it is compact.

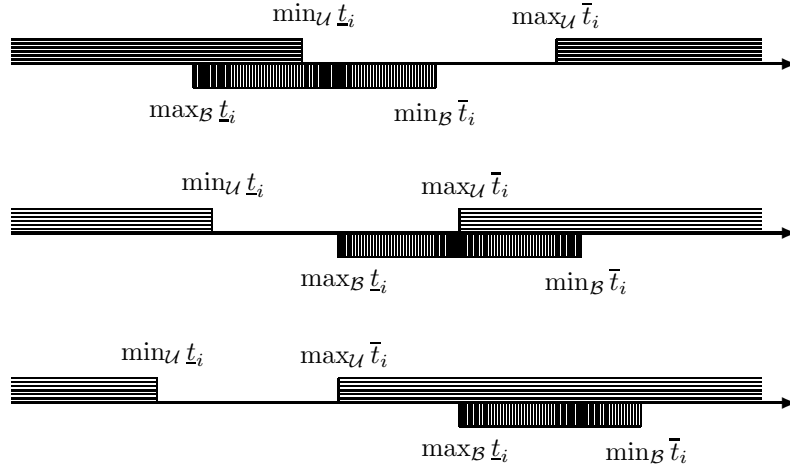

Figure 2: Various situations in the definition of $\Omega(\mathbf{r})$.

As was already noted, the function $\Omega(\mathbf{r})$ is not even continuous on its effective domain in general. If $\mathbf{r} \in \text{dom } \Omega$, then

$$\begin{aligned} \Omega(\mathbf{r}) &= \max_{i \in \mathcal{B}} \underline{t}_i && \text{if } \min_{i \in \mathcal{U}} \underline{t}_i \geq \max_{i \in \mathcal{B}} \underline{t}_i, \\ \text{and } \Omega(\mathbf{r}) &= \max \left\{ \max_{i \in \mathcal{B}} \underline{t}_i, \max_{i \in \mathcal{U}} \bar{t}_i \right\} && \text{if } \min_{i \in \mathcal{U}} \underline{t}_i < \max_{i \in \mathcal{B}} \underline{t}_i \end{aligned}$$

(Fig. 2 depicts various situations). Let $\text{dom } \Omega = \mathcal{D}_0 \cup \mathcal{D}_1$, where

$$\begin{aligned} \mathcal{D}_0 &= \left\{ \mathbf{r} \in \text{dom } \Omega \subseteq \mathbb{R}^{n-1} \mid \min_{i \in \mathcal{U}} \underline{t}_i \geq \max_{i \in \mathcal{B}} \underline{t}_i \right\}, \\ \mathcal{D}_1 &= \left\{ \mathbf{r} \in \text{dom } \Omega \subseteq \mathbb{R}^{n-1} \mid \min_{i \in \mathcal{U}} \underline{t}_i < \max_{i \in \mathcal{B}} \underline{t}_i \right\}. \end{aligned}$$

Then the function $\Omega(\mathbf{r})$ can be defined in the following way:

$$\Omega(\mathbf{r}) = \begin{cases} \max_{i \in \mathcal{B}} \underline{t}_i, & \text{if } \mathbf{r} \in \mathcal{D}_0, \\ \max \left\{ \max_{i \in \mathcal{B}} \underline{t}_i, \max_{i \in \mathcal{U}} \bar{t}_i \right\}, & \text{if } \mathbf{r} \in \mathcal{D}_1, \\ +\infty, & \text{if } \mathbf{r} \in \mathcal{V} \setminus (\mathcal{D}_0 \cup \mathcal{D}_1), \end{cases}$$

and $\Omega(\mathbf{r}') < \Omega(\mathbf{r}'') < +\infty$ for any $\mathbf{r}' \in \mathcal{D}_0$, $\mathbf{r}'' \in \mathcal{D}_1$.

Being described by non-strict inequality between continuous functions, \mathcal{D}_0 is closed, and $\Omega(\mathbf{r})$ is continuous on both \mathcal{D}_0 and \mathcal{D}_1 . So the Lebesgue set $\{\Omega \leq c\}$ is closed for any $c \leq \sup\{\Omega(\mathbf{r}) \mid \mathbf{r} \in \mathcal{D}_0\}$. Suppose now that $c > \sup\{\Omega(\mathbf{r}) \mid \mathbf{r} \in \mathcal{D}_0\}$. Then all limit points of $\{\Omega \leq c\}$ can belong to $\mathcal{D}_0 \cup \mathcal{D}_1$ only because of the openness of the complement $\mathcal{V} \setminus (\mathcal{D}_0 \cup \mathcal{D}_1)$. But the set $\{\Omega \leq c\} \cap \mathcal{D}_0 = \mathcal{D}_0$ is closed in \mathbb{R}^{n-1} and the set $\{\Omega \leq c\} \cap \mathcal{D}_1$ is closed in \mathcal{D}_1 . Hence $\{\Omega \leq c\} \cap \mathcal{D}_0$ contains all limit points of

$\{\Omega \leq c\}$ belonging to \mathcal{D}_0 , while $\{\Omega \leq c\} \cap \mathcal{D}_1$ contains all limit points of $\{\Omega \leq c\}$ belonging to \mathcal{D}_1 . Since

$$\{\Omega \leq c\} = (\{\Omega \leq c\} \cap \mathcal{D}_0) \cup (\{\Omega \leq c\} \cap \mathcal{D}_1),$$

we thus get the closure of the Lebesgue set $\{\Omega \leq c\}$ for $c > \sup\{\Omega(\mathbf{r}) \mid \mathbf{r} \in \mathcal{D}_0\}$ as well. This completes the proof of lower semicontinuity of $\Omega(\mathbf{r})$. \square

Lemma 2 *In the PSS algorithm, the sums of the component lengths of the leading boxes tend to zero.*

Proof. We will show that the sequence $\{\vartheta^{(k)}\}$ of component length sums of the leading boxes is majorized by some sequence $\{\Theta^{(k)}\} \rightarrow 0$. Define

$\vartheta(\mathbf{P})$ = the sum of the component lengths of a box \mathbf{P} ,

$\lambda^{(k)}$ = the set of all boxes \mathbf{P} such that the pair $(\mathbf{P}, \Omega(\mathbf{P}))$ is contained in the list L at the beginning of the k th algorithm step and then becomes the leading one at a step with some number $\geq k$.

It is not hard to see that if

$$\Theta^{(k)} = \max\{\vartheta(\mathbf{P}) \mid \mathbf{P} \in \lambda^{(k)}\}$$

then $\Theta^{(k)} \geq 0$, and the sequence $\{\Theta^{(k)}\}$ is non-increasing. Indeed, the set $\lambda^{(k+1)}$ contains all boxes from $\lambda^{(k)}$ except the box \mathbf{Q} that was the leading one at the k th step: instead of \mathbf{Q} the set $\lambda^{(k+1)}$ may contain or not contain its descendants \mathbf{Q}' and \mathbf{Q}'' . Since

$$\vartheta(\mathbf{Q}) > \vartheta(\mathbf{Q}') \quad \text{and} \quad \vartheta(\mathbf{Q}) > \vartheta(\mathbf{Q}''),$$

we conclude

$$\Theta^{(k)} = \max\{\vartheta(\mathbf{P}) \mid \mathbf{P} \in \lambda^{(k)}\} \geq \max\{\vartheta(\mathbf{P}) \mid \mathbf{P} \in \lambda^{(k+1)}\} = \Theta^{(k+1)} > 0.$$

Now, what is $\lim_{k \rightarrow \infty} \Theta^{(k)}$, a limit which is known to exist by the well known Weierstrass' theorem?

When $\lim \Theta^{(k)} = \delta > 0$ there is positive integer μ such that

$$\frac{2n}{2n-1} \delta > \Theta^{(k)} \geq \delta,$$

provided $k > \mu$ (n denotes dimension) and therefore

$$\frac{2n}{2n-1} \delta > \vartheta(\mathbf{P})$$

for all $\mathbf{P} \in \lambda^{(k)}$, $k > \mu$. Having fixed $\varrho > \mu$, consider any box $\mathbf{P} \in \lambda^{(\varrho)}$. Suppose the largest term in the sum $\vartheta(\mathbf{P})$ corresponds to the j th component of \mathbf{P} . According to the very definition of $\lambda^{(\varrho)}$ there exists a positive integer $\mu_{\mathbf{P}}$, $\mu_{\mathbf{P}} > \varrho > \mu$, such that \mathbf{P} will become the leading box at the $\mu_{\mathbf{P}}$ th step of PSS algorithm. At the same time it will be bisected on its j th component, and for every descendant \mathbf{P}' of \mathbf{P} there holds

$$\vartheta(\mathbf{P}') \leq \vartheta(\mathbf{P}) - \vartheta(\mathbf{P})/2n = \frac{2n-1}{2n} \vartheta(\mathbf{P}) < \delta.$$

If $M = \max\{\mu_{\mathbf{P}} \mid \mathbf{P} \in \lambda^{(\varrho)}\}$, then this inequality is valid for all boxes from the set $\lambda^{(M+1)}$. But this contradicts the assumption $\Theta^{(k)} \geq \delta > 0$. Therefore, $\lim \Theta^{(k)} = 0$ as required. \square

The analogous result has been also obtained by Ratschek [25], but in another way.

THEOREM. *Let the interval linear algebraic system $\mathbf{A}x = \mathbf{b}$ and interval vector $\mathbf{V} \supseteq \Sigma$ be such that the condition (NZ) holds. Then, in the PSS algorithm of §2 with the initial approximation \mathbf{V} , the sequence of the leading estimates converges to $\min\{x_\nu \mid x \in \Sigma\}$ from below.*

Proof. As we have mentioned, for leading boxes \mathbf{Q} in the kind of algorithm under consideration, the estimate

$$\Omega(\mathbf{Q}) \leq \min\{x_\nu \mid x \in \Sigma\} \quad (13)$$

has been already established by Ratschek [25] too, and so we are to prove the proper convergence of the PSS algorithm.

Denote by \mathcal{W} the set of all point vectors from \mathcal{V} , i.e., the set $\mathcal{V} \cap \mathbb{R}^{n-1}$. The further reasoning depends heavily on whether we have $\mathcal{W} \cap \mathcal{D}_0 \neq \emptyset$ or $\mathcal{W} \cap \mathcal{D}_0 = \emptyset$, where \mathcal{D}_0 and \mathcal{D}_1 are defined in the proof of the Lemma 1.

If $\mathcal{W} \cap \mathcal{D}_0 \neq \emptyset$, then all leading boxes \mathbf{Q} belong to \mathcal{D}_0 . In fact, for any $p \in \mathcal{W} \cap \mathcal{D}_0$, the inequality $\Omega(p) \geq \min\{x_\nu \mid x \in \Sigma\}$ is valid. In case $\mathbf{Q} \in \mathcal{D}_1$ we would have $\Omega(\mathbf{Q}) > \Omega(p)$, and so

$$\Omega(\mathbf{Q}) > \min\{x_\nu \mid x \in \Sigma\},$$

which is contrary to (13).

Whenever $\mathbf{r} \in \mathcal{D}_0$,

$$\min\{\Omega(r) \mid (r \in \mathbb{R}^{n-1}) \& (r \in \mathbf{r})\} = \Omega(\check{r}) \quad (14)$$

for some real $\check{r} \in \mathbf{r}$, $\check{r} \in \mathbb{R}^{n-1}$, as long as the lower semicontinuous function $\Omega(\mathbf{r})$ attains its smallest value on the compact set $\{r \in \mathbb{R}^{n-1} \mid r \in \mathbf{r}\}$ [33]. But $\|\check{r} - \mathbf{r}\| \leq 2 \|\text{rad } \mathbf{r}\|$. So, due to uniform continuity of $\Omega(\mathbf{r})$ on \mathcal{D}_0 , for any $\epsilon > 0$ there exists a $\delta > 0$ such that

$$0 \leq \min\{\Omega(r) \mid r \in \mathbf{r}\} - \Omega(\mathbf{r}) \leq \epsilon \quad (15)$$

when $\|\text{rad } \mathbf{r}\| \leq \delta$ (therefore, under the condition (NZ), we have rigorously substantiated the assertion of §2 that the accuracy of estimating (10) by means of $\Omega(\mathbf{r})$ is higher the thinner the vector \mathbf{r} is).

Now the convergence of the PSS algorithm of §2 can be easily proved. If $\{\mathbf{Q}^{(k)}\}$ is the sequence of leading boxes (as before, k is a step number), then $\|\text{rad } \mathbf{Q}^{(k)}\| \rightarrow 0$ by the Lemma 2. Hence for any $\epsilon > 0$ there is a positive integer K_ϵ , such that, in analogy to inequality (15),

$$0 \leq \min\{\Omega(r) \mid r \in \mathbf{Q}^{(k)}\} - \Omega(\mathbf{Q}^{(k)}) \leq \epsilon$$

holds for $k \geq K_\epsilon$. Also making use of

$$\begin{aligned} \Omega(\mathbf{Q}^{(k)}) &\leq \min\{x_\nu \mid x \in \Sigma\} \\ &= \min\{\Omega(r) \mid r \in (\mathbf{V}_1, \dots, \mathbf{V}_{\nu-1}, \mathbf{V}_{\nu+1}, \dots, \mathbf{V}_n)\} \\ &\leq \min\{\Omega(r) \mid r \in \mathbf{Q}^{(k)}\}, \end{aligned}$$

we may conclude that

$$0 \leq \min\{x_\nu \mid x \in \Sigma\} - \Omega(\mathbf{Q}^{(k)}) \leq \epsilon \quad \text{for } k \geq K_\epsilon.$$

This means convergence of the simplest PSS algorithm.

Evidently the above conclusion remains valid if $\mathcal{D}_0 = \emptyset$ (in which case $\text{dom } \Omega = \mathcal{D}_1$). To prove this we need only replace \mathcal{D}_0 by \mathcal{D}_1 in all of the preceding arguments beginning from (14).

Consider now the case $\mathcal{D}_0 \neq \emptyset$ and $\mathcal{W} \cap \mathcal{D}_0 = \emptyset$. Let

$$\min\{\|\mathbf{r} - r\| \mid (\mathbf{r} \in \mathcal{D}_0) \& (r \in \mathcal{W})\} = 2\tau.$$

It is clear that $\tau > 0$, since \mathcal{W} and \mathcal{D}_0 are nonintersecting compact sets. Then the set

$$\left\{ \mathbf{r} \in \text{dom } \Omega \mid \min_{r \in \mathcal{W}} \|\mathbf{r} - r\| \leq \tau \right\} \quad (16)$$

also does not intersect \mathcal{D}_0 , i.e., it is wholly contained in \mathcal{D}_1 . For any \mathbf{r} and r , obviously $\|\mathbf{r} - r\| \geq \|\text{rad } \mathbf{r}\|$, so that

$$\min_r \|\mathbf{r} - r\| \geq \|\text{rad } \mathbf{r}\|.$$

Hence the set (16) as well as \mathcal{D}_1 contains the subset

$$\mathcal{D}_\tau = \{ \mathbf{r} \in \text{dom } \Omega \mid \|\text{rad } \mathbf{r}\| \leq \tau \},$$

to which all leading boxes beginning with some iteration belong. The rest of the argument is analogous to that of the previous case: since the function $\Omega(\mathbf{r})$ is uniformly continuous on the compact set \mathcal{D}_τ , inequality (15) holds and so on.

The theorem is thus completely proved. \square

The second term of the disjunctions in the assumption (NZ) is hardly verifiable in the original form, but using interval arithmetic a simple sufficient condition can be given for (NZ) to be fulfilled:

$$\begin{aligned} &\text{for each } i = 1, 2, \dots, m, \\ &\text{zero is not an endpoint of } \mathbf{a}_{i\nu} \text{ or } 0 \notin (\mathbf{b}_i - \sum_{j=1, j \neq \nu}^n \mathbf{a}_{ij} \mathbf{V}_j). \end{aligned}$$

We would like to emphasize, however, that one should not overestimate the practical significance of the simplest PSS algorithm (see §5). The main idea of the basic method described above ought to be further developed and updated to result in highly perfected computational procedures.

4 Improvements

Applying the simplest PSS algorithm directly to practical problems would evidently be unwise, notwithstanding its above convergence proof. This algorithm can be considerably improved in many ways which are already standard for this kind of method. Usually, such algorithms contain the following modifications (see [2, 5, 10, 26] and other works):

- tracing values of the objective function at some points of boxes along with evaluating over entire boxes enables one to control the precision of the approximation to $\min\{x_\nu \mid x \in \Sigma\}$ and to delete useless pairs (that never become leading pairs) from the list L ; thanks to the last property, growth of the list L size is confined to some extent;
- after revealing monotonicity of the objective function in some variables, one reduces the dimension of boxes from the list L ;
- based upon local characteristics of the objective function, one employs minimization procedures in appropriate boxes which are more effective than bisection;
- one constructs a higher quality (more accurate) inclusion function for the objective function.

The latter three improvements are involved ones, and we postpone their careful consideration until a future part of this work, so as not to overload our account. Here we confine ourselves only to the first of the above items, since without it the realization of the simplest PSS algorithm may turn out rather difficult even for systems of small dimension (see the next section).

Now, let $\xi(\mathbf{P})$ be a point from \mathbf{P} and let us compute $\Omega(\xi(\mathbf{P}))$ along with the estimate $\Omega(\mathbf{P})$ for boxes \mathbf{P} constructed by the algorithm. It is evident that $\Omega(\xi(\mathbf{P})) \leq \Omega(\mathbf{P})$ and values $\Omega(\xi(\mathbf{P}))$ approximate $\min\{x_\nu \mid x \in \Sigma\}$ from above: if for each step of the algorithm we define

$$\omega = \min \Omega(\xi(\mathbf{P})), \tag{17}$$

where the minimum is taken over all such boxes \mathbf{P} of which corresponding pairs have ever been in the list L up to the current step, then, always,

$$\min\{x_\nu \mid x \in \Sigma\} \leq \omega.$$

On the other hand, given a leading box \mathbf{Q} ,

$$\Omega(\mathbf{Q}) \leq \min\{x_\nu \mid x \in \Sigma\},$$

and we may now terminate iteration when the quantity $(\omega - \Omega(\mathbf{Q}))$ is sufficiently small.

Therefore a pair $(\mathbf{P}, \Omega(\mathbf{P}))$ that satisfies

$$\Omega(\mathbf{P}) > \omega \tag{18}$$

at a some step, never becomes a leading one, and deleting it from the list L has no effect on the algorithm's performance. This condition is *a priori* contended for boxes \mathbf{P} with $\Omega(\mathbf{P}) = +\infty$ (it immediately implies $\Omega(\xi(\mathbf{P})) = +\infty$) and corresponding pairs do not even need to be placed into L . Altogether, by means of (18) we have to test all newly generated pairs at each step of the algorithm, but complete cleaning of the list L — running through it and deleting pairs satisfying (18) — makes sense only after the parameter ω changes (i.e., decreases).

The ideal choice for $\xi(\mathbf{P})$ is, of course,

$$\xi(\mathbf{P}) \in \text{Arg min} \{ \Omega(r) \mid r \in \mathbf{P} \}.$$

In general, however, finding such lucky $\xi(\mathbf{P})$ is at any rate no easier than solving the initial problem, so we shall take $\xi(\mathbf{P}) = \text{mid } \mathbf{P}$ to minimize any possible deviation of $\xi(\mathbf{P})$ from the set $\text{Arg min} \{ \Omega(r) \mid r \in \mathbf{P} \}$.

To summarize, we come to a slightly more perfect version of the PSS algorithm to compute $\min\{x_\nu \mid x \in \Sigma\}$. As before it operates with the list L of pairs

$$(\mathbf{P}, \Omega(\mathbf{P})),$$

$\mathbf{P} \subseteq (\mathbf{V}_1, \dots, \mathbf{V}_{\nu-1}, \mathbf{V}_{\nu+1}, \dots, \mathbf{V}_n)$, ordered in terms of increasing values $\Omega(\mathbf{P})$. In addition, the real parameter ω defined by (17) is associated with the algorithm. At the start the list L consists of the single pair

$$((\mathbf{V}_1, \dots, \mathbf{V}_{\nu-1}, \mathbf{V}_{\nu+1}, \dots, \mathbf{V}_n), \underline{\mathbf{V}}_\nu),$$

and ω is set equal to $\overline{\mathbf{V}}_\nu$. One step of execution of the algorithm is made up of the following stages:

1. If $(\omega - \Omega(\mathbf{Q})) \leq \epsilon$, then stop.
2. In the leading box \mathbf{Q} choose the largest component \mathbf{Q}_ι .
3. Bisect the leading box along the component ι to subboxes \mathbf{Q}' and \mathbf{Q}'' .
4. Remove the previous leading pair $(\mathbf{Q}, \Omega(\mathbf{Q}))$ from the list L .
5. Compute $\Omega(\mathbf{Q}')$.
6. If $\Omega(\mathbf{Q}') \leq \omega$, then insert the new pair $(\mathbf{Q}', \Omega(\mathbf{Q}'))$ into L in the proper order (of increasing second member).
7. Compute $\Omega(\mathbf{Q}'')$.
8. If $\Omega(\mathbf{Q}'') \leq \omega$, then insert the new pair $(\mathbf{Q}'', \Omega(\mathbf{Q}''))$ into L in the proper order.

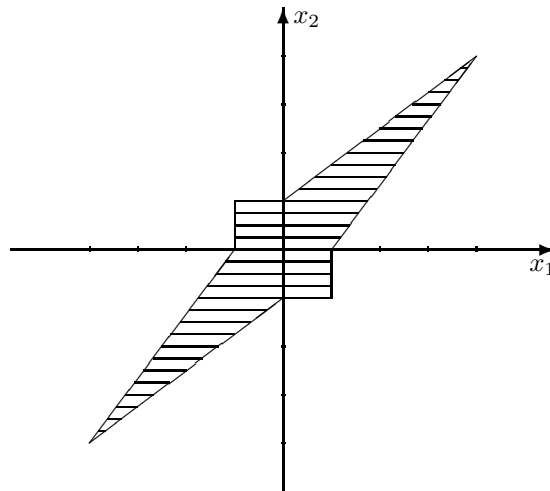

Figure 3: The solution set to (20).

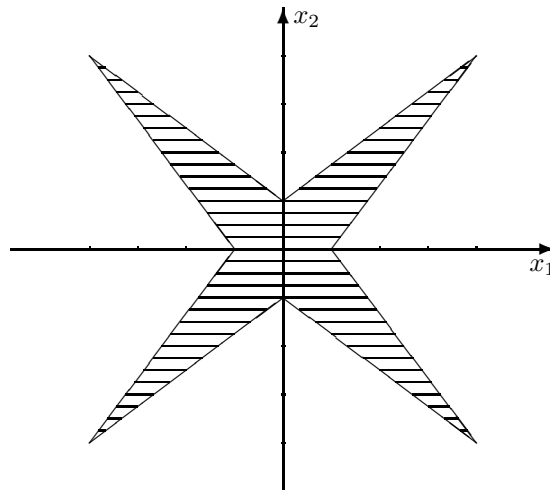

Figure 4: The solution set to (21).

since the right-hand side interval vector is symmetric around the zero. Hence, the solution set $\tilde{\Sigma}$ is centrally symmetric with respect to the origin of coordinates, and, in particular,

$$\min\{x_i \mid x \in \tilde{\Sigma}\} = -\max\{x_i \mid x \in \tilde{\Sigma}\}, \quad i = 1, 2, \dots, n. \tag{22}$$

Further, after the change of x_i for x_j and vice versa for any $i, j \in \{1, 2, \dots, n\}$, the ILAS (19) also remains the same. We can conclude from this that the set $\tilde{\Sigma}$ is symmetric around the bisectrix of the positive and negative orthants of \mathbb{R}^n and

$$\begin{aligned} \min\{x_i \mid x \in \tilde{\Sigma}\} &= \min\{x_j \mid x \in \tilde{\Sigma}\}, \\ \max\{x_i \mid x \in \tilde{\Sigma}\} &= \max\{x_j \mid x \in \tilde{\Sigma}\} \end{aligned}$$

for any $i, j \in \{1, 2, \dots, n\}$. Combining this relationships with (22), we obtain finally that the interval hull of the set $\tilde{\Sigma}$, i.e., the optimal interval solution of the ILAS (19), is a hypercube with the center in the origin of coordinates. To determine its size, we put $x_1 = x_2 = \dots = x_n$ in (19) and then all the equations of this system merge into one

$$[n - 1; N] \cdot x_1 + (n - 1)[\alpha - 1; 1 - \beta] \cdot x_1 = [1 - n; n - 1],$$

or

$$[1; N/(n-1)] \cdot x_1 + [\alpha - 1; 1 - \beta] \cdot x_1 = [-1; 1].$$

When solving the outer problem for this equation the variable x_1 is to be treated as a *real number*, and so, due to distributivity [1, 16, 18], we come to

$$[\alpha; 1 - \beta + N/(n-1)] \cdot x_1 = [-1; 1].$$

The solution set to this interval equation is

$$x_1 = [-1/\alpha; 1/\alpha],$$

and so the optimal (exact) componentwise estimates for the solution set of the system (19) are

$$\begin{aligned} \min\{x_i \mid x \in \tilde{\Sigma}\} &= -1/\alpha, \\ \max\{x_i \mid x \in \tilde{\Sigma}\} &= 1/\alpha, \quad i = 1, 2, \dots, n, \end{aligned}$$

no matter what the value of N is.

Now let us consider and comment results of the test computations with the PSS algorithm of §4 applied to the model ILAS (19) with variable dimension for $\alpha = \frac{1}{4}$, $\beta = 1$ (Table 1) and for $\alpha = \beta = \frac{1}{4}$ (Table 2). It follows from the foregoing that the interval hull of the solution sets of these systems is the interval vector $([-4; 4], \dots, [-4; 4])^\top$, but we wittingly took the nonsymmetric intervals $([-5; 6], \dots, [-5; 6])^\top$ and $([-7; 10], \dots, [-7; 10])^\top$ as the initial approximation vectors. In view of the features of the PSS algorithm and the model problem, the Tables below report expenditures for computing the estimate of $\min\{x_1 \mid x \in \Sigma\}$ only, since for symmetry reason they are the same for any other component. The termination criterion was $(\omega - \Omega(\mathbf{Q})) \leq 0.1$, i.e., the condition of achieving the absolute accuracy no less than 0.1. As a summarizing expenditure measure (though very subjective one), running times of the algorithm are included in the Tables.

As is seen from these Tables, the running expenditures of the PSS algorithm grow exponentially with the dimension of the problem. This thesis may be substantiated through conceptual reasoning as well.

The complexity of the PSS algorithms as applied to each specific ILAS depends on the structure of its solution set, but the worst case is provided for the PSS algorithm by the model system (19) with $\alpha = \beta$. In fact, let us simulate the PSS algorithm as a process of global optimization of the function $\Omega(r)$ from the representation (8). At the beginning of the algorithm's performance the leading boxes concentrate around local minimums of the objective function $\Omega(r)$ on $(\mathbf{V}_1, \dots, \mathbf{V}_{\nu-1}, \mathbf{V}_{\nu+1}, \dots, \mathbf{V}_n)$. Further, as the sufficient improvement of these local minimums is being achieved (i.e., as the leading boxes become thinner), the algorithm gradually discards those of them which are not global minimums. More exactly, the nonglobal local minimums have neighborhoods into which the leading boxes does not already fall beginning with some step. Sooner or later, all the leading boxes will concentrate around the global minimums only (there can be several of them), the algorithm accomplishing the final refinement of the result. Naturally, some stages may fail in this scheme for concrete ILAS.

If $0 < \alpha = \beta < 1$, the solution set to the system (19) is symmetric in every respect, its intersections with all orthants of \mathbb{R}^n being congruent to each other. Correspondingly, there is just one local minimum of the objective function $\Omega(r)$ from the representation (8) in each of intersections of the domain vector $(\mathbf{V}_1, \dots, \mathbf{V}_{\nu-1}, \mathbf{V}_{\nu+1}, \dots, \mathbf{V}_n)$ with orthants of \mathbb{R}^{n-1} (so that there are 2^{n-1} altogether), with magnitudes of all these local minimums being the same and equal to $-1/\alpha$. The execution of the PSS algorithm as applied to (19) with $\alpha = \beta$ proceeds in accordance with the described above standard scenario: after some iterations the list L breaks up into nonintersecting subsets L', L'', \dots of records, belonging to which boxes thicken in neighborhoods of local minimums of the objective function $\Omega(r)$. But now, since all the local minimums are equal to each other, their refinement, however thorough,

Table 1: Solving the test system (19) with $\alpha = 1/4$, $\beta = 1$.

Dimension	Number of iterations	Time	Maximum list size
initial approximation $([-5; 6], \dots)^\top$			
2	11	—	8
3	36	0.06 s	23
4	96	0.44 s	58
5	369	2.42 s	232
6	1203	11.4 s	787
initial approximation $([-7; 10], \dots)^\top$			
2	12	—	9
3	43	0.11 s	27
4	177	0.36 s	91
5	573	3.79 s	397
6	2073	20.5 s	1430

Table 2: Solving the test system (19) with $\alpha = \beta = 1/4$.

Dimension	Number of iterations	Time	Maximum list size
initial approximation $([-5; 6], \dots)^\top$			
2	22	0.05 s	14
3	164	0.38 s	113
4	931	4.12 s	613
5	5986	57.3 s	4007
initial approximation $([-7; 10], \dots)^\top$			
2	25	0.05 s	9
3	191	0.5 s	65
4	1272	5.54 s	508
5	7507	66.1 s	2966

can detect neither smallest (i.e., the best) nor useless of them, and each of L' , L'' , ... never becomes empty.

As a matter of fact, the objective function $\Omega(r)$, corresponding to the ILAS (19) with $\alpha = \beta$, has the number of local extrema that increases exponentially with the dimension n , and each of them requires from the algorithm separate refinement, for which nondecreasing time and storage are expended. Therefore, the complexity of executing the PSS algorithm, which is necessary for attaining any given absolute or relative accuracy, is proportional to at least 2^n at the worst.

6 Discussion

At present three computational approaches exist for computing optimal solutions of the outer problem for general ILAS (for an overview of partial results on this subject see [21]). The first one originates from the work by Oettli [22], who had discovered that the intersection of the solution set with each orthant of \mathbb{R}^n is a convex polyhedron. Thus the exact value of $\min\{x_\nu \mid x \in \Sigma\}$ can be found through solving some linear programming problem in each of the orthants and then picking the minimum of the results. Some aspects of this approach are also discussed in [3, 11]. The algorithm, however, is seen to be based upon a passive exhausting strategy while its complexity is exponential in dimension n , and owing to this it is of low practical significance.

The next computational approach to optimal solution of the outer problem for square interval linear systems is the recently advanced PPS algorithm [30]. With the “branch and bound method” as a basis, it has become a logical completion of ideas by Hansen [8], Nickel [19] and some other researchers. Though in the worst case the complexity of the PPS algorithm may prove proportional even to 2^{n^2} , it is an adaptive (sequential) algorithm as opposed to the previous approach. That is, when executing each subsequent step of the PPS algorithm, the information about its earlier steps is utilized in full scale. This type of algorithm is preferable in practical computation, as long as it has flexible computational scheme that allows to accommodate itself to each specific problem. By and large the PPS algorithm looks very promising, but at present it is not sufficiently elaborated yet.

Finally, the third and for the time being the most developed approach to optimal solution of the outer problem is due to Rohn [27] (see also [18]). Starting from the Oettli-Prager characterization of the solution set, he shows that, in the case of square nonsingular matrix \mathbf{A} , the required $\min\{x_\nu \mid x \in \Sigma\}$ and $\max\{x_\nu \mid x \in \Sigma\}$, $\nu = 1, 2, \dots, n$, are reached on the set of at most 2^n solutions to the equation

$$|\text{mid } \mathbf{A} \cdot x - \text{mid } \mathbf{b}| = \text{rad } \mathbf{A} \cdot |x| + \text{rad } \mathbf{b}. \quad (23)$$

Computing all these solutions and comparing them with each other, we shall get optimal estimates of the solution set after finite number of steps. Since the process of determining each next solution to (23) in no way depends upon the solutions found earlier, the Rohn’s algorithm as a whole is not adaptive (i.e., it is similar to exhausting methods), whereas its complexity is proportional to 4^n at the worst.

Thus, all the approaches so far advanced to compute the optimal solutions of the outer problem for general ILAS as well as the above constructed PSS algorithm have exponential complexity. This fact, however, is not the fault of these algorithms, but reflects profound properties of the very united solution set to interval linear system. Large labor requirements that the problems dealt with estimation of the united solution set establish, actually, combinatorial character of these problems have been repeatedly pointed out by many researchers. At last, Lakeyev and Noskov have proved that the recognition of whether $\Sigma = \emptyset$ or not is NP-complete [14], and Kreinovich has established recently that the optimal solution of the outer problem (3) is NP-hard too [13]. Therefore, the exponential complexity of all the algorithms listed above is essential and can not be overcome (provided $P \neq NP$) [6].

What are advantages and shortcomings of the PSS algorithm as compared to the other approaches to compute optimal solutions of the outer problem? The numerical experiments demonstrate that

it is of low efficiency, though, in my opinion, having realized the modifications mentioned in §4, we can crucially improve the situation. On the other hand, the PSS algorithm is adaptive (sequential), and this is not all yet. The other important feature of the PSS algorithm is that it generates the sequence of estimates to the sought-for values from the necessary sides, i.e., for $\min\{x_\nu \mid x \in \Sigma\}$ from below and for $\max\{x_\nu \mid x \in \Sigma\}$ from above. Just such estimates are required in accordance with the sense of the outer problem. The process of the PSS algorithm's performance decomposes into a sequence of efficiently computed stages, and as the result of each one we have a solution of the outer problem. Hence, having stopped the PSS algorithm at any moment after some sufficient time, we will altogether get more or less exact solution to the outer problem in the form of current leading estimate. In other words, if we have sufficient computer capacity at our disposal, then employing the PSS algorithm we may be fairly confident that an answer to the outer problem will be obtained for sure, though perhaps not optimal one. Such is the PPS algorithm too, and we propose to designate their common aforementioned property by a special term, speaking that the PSS algorithm and the PPS algorithm are *sequentially guaranteeing*. Taking into account the intractability of the outer problem, this radically distinguishes the PSS and PPS algorithms from all the other methods for determining optimal solutions.

Nowadays the notion "efficiently computed" is equivalent to "polynomially computed", i.e., computed for the time (or the number of elementary computer operations) bounded by a polynomial function of the input length. In view of this, we can reformulate the definition of sequentially guaranteeing algorithm more precisely in the following way: *an algorithm is said to be a sequentially guaranteeing if, when executed, it generates a sequence (finite or infinite) of polynomially computed correct answers to the problem under solution*. In particular, an algorithm is a priori sequentially guaranteeing if it is polynomially complex by itself. The final result may be the limit of infinite sequence of intermediate answers (in common with the PSS algorithm) or the last term of a finite sequence of intermediate answers (as for the PPS algorithm) or somehow otherwise.

On the contrary, the other two of the approaches reviewed above for computing optimal solution of the outer problem, having exponential complexity at the worst, provide the desired "outer" estimates of the solution set only in the final, when their performance is naturally finished, since earlier we can not guarantee that the calculated estimate is really $\leq \min\{x_\nu \mid x \in \Sigma\}$ (or $\geq \max\{x_\nu \mid x \in \Sigma\}$). For this reason it would be advisable to refer to such algorithms as *finally guaranteeing*. If the dimensionality of interval linear system is sufficiently large (a mere several tens), then, by virtue of intractability of the outer problem, the number of arithmetical and logical operations which is necessary for the problem to be certainly solved is much more than the number of operations a computer can execute during any reasonable time. In these conditions, one can not be sure that the finally guaranteeing algorithm will have completed its work and, consequently, that an answer will be obtained to the problem posed. Put otherwise, in applying the finally guaranteeing algorithm we risk wasting time and money without getting any answer to the problem.

This pessimistic forecast is especially telling for passive exhaustive algorithms, that is, for the approaches by Oettli and by Rohn to the optimal solution of the outer problem. If these algorithms were adaptive (sequential), things would get somewhat better, since then their exponential complexity would be reached only at the worst and this may not be the case for our concrete problem. In any event, however, finally guaranteeing algorithms appear to be of limited utility for practical solution of large intractable problems to which an answer must meet some qualitative requirement. A natural way out of this difficulty is to reconstruct the algorithm so that it produces some inexpensively computed intervening results before its full completion, which are more or less accurate proper solutions to our problem. This is just what is implied by the definition of sequentially guaranteeing algorithm.

References

- [1] G. ALEFELD AND J. HERZBERGER, *Introduction to Interval Computations*, Academic Press, New

- York, 1983.
- [2] N. S. ASAITHAMBI, SHEN ZUHE AND R. E. MOORE, *On computing the range of values*, Computing, 28 (1982), pp. 225–237.
 - [3] H. BEECK, *Über die Struktur und Abschätzungen der Lösungsmenge von linearen Gleichungssystemen mit Intervallkoeffizienten*, Computing, 10 (1972), pp. 231–244.
 - [4] YU. G. EVTUSHENKO, *Numerical method for finding the global extremum of a function*, J. Comp. Mathem. and Math. Physics, 11 (1971), pp. 1390–1403. (in Russian)
 - [5] YU. G. EVTUSHENKO AND V. A. RAT’KIN, *Bisection method for global optimization of multivariable functions*, Izvestiya AN SSSR. Technical cybernetics, No. 1 (1987), pp. 119–127. (in Russian)
 - [6] M. R. GAREY AND D. S. JOHNSON, *Computers and Intractability: A Guide to the Theory of NP-Completeness*, W. H. Freeman and Co., San Francisco, 1979.
 - [7] D. M. GAY, *Solving interval linear equations*, SIAM J. Numer. Anal., 19 (1982), pp. 858–870.
 - [8] E. HANSEN, *On linear algebraic equations with interval coefficients*, in Topics in Interval Analysis, E. Hansen, ed., Oxford University Press, Oxford, 1969, pp. 35–46.
 - [9] E. HANSEN, *Bounding the solution of interval linear equations*, SIAM J. Numer. Anal., 29 (1992), pp. 1493–1503.
 - [10] E. HANSEN, *Global Optimization Using Interval Analysis*, Marcel Dekker, New York, 1992.
 - [11] D. J. HARTFIEL, *Concerning the solution set of $Ax = b$ where $P \leq A \leq Q$ and $p \leq b \leq q$* , Numer. Math., 35 (1980), pp. 355–359.
 - [12] C. JANSSON, *A global minimization method using interval arithmetic*, in Computer Arithmetic and Enclosure Methods, L. Atanassova and J. Herzberger, eds., IMACS Annals of Computing and Applied Mathematics, Elsevier, 1992, pp. 259–267.
 - [13] V. KREINOVICH, A. V. LAKEYEV, AND S. I. NOSKOV, *Optimal solution of interval linear systems is intractable (NP-hard)*, Interval Computations, 1 (1993), pp. 6–14.
 - [14] A. V. LAKEYEV AND S. I. NOSKOV, *Description of the solution set to a linear equation with intervally defined operator and right-hand side*, Doklady Akademii Nauk, 330 (1993), No. 4, pp. 430–433. (in Russian)
 - [15] S. E. LAVEUVE, *Definition einer Kahan-Arithmetik und ihre Implementierung*, in Interval Mathematics 1975, K. Nickel, ed., Lecture Notes in Computer Science, 29, Springer-Verlag, Berlin, 1975, pp. 236–245.
 - [16] R. E. MOORE, *Methods and Applications of Interval Analysis*, SIAM, Philadelphia, 1979.
 - [17] A. NEUMAIER, *Linear interval equations*, in Interval Mathematics 1985, K. Nickel, ed., Lecture Notes in Computer Science, 212, Springer-Verlag, Berlin, 1986, pp. 109–120.
 - [18] A. NEUMAIER, *Interval Methods for Systems of Equations*, Cambridge University Press, Cambridge, 1990.
 - [19] K. NICKEL, *Die Überschätzung des Wertebereichs einer Funktion in der Intervallrechnung mit Anwendungen auf linearer Gleichungssysteme*, Computing, 18 (1977), pp. 15–36.

- [20] E. NUDING AND J. WILHELM, *Über Gleichungen und über Lösungen*, ZAMM, 52 (1972), pp. T188–T190.
- [21] E. NUDING, *Schrankentreue Algorithmen*, Beiträge zur numerische Mathematik, 11 (1983), pp. 115–137.
- [22] W. OETTLI, *On the solution set of a linear system with inaccurate coefficients*, SIAM J. Numer. Anal., 2 (1965), pp. 115–118.
- [23] CH. PAPADIMITRIOU AND K. STEIGLITZ, *Combinatorial Optimization: Algorithms and Complexity*, Prentice-Hall, Englewood Cliffs, 1982.
- [24] S. A. PIYAVSKII, *An algorithm for finding the absolute extremum of a function*, J. Comp. Mathem. and Math. Physics, 12 (1972), No. 4, pp. 888–896. (in Russian)
- [25] H. RATSCHKE, *Inclusion functions and global optimization*, Math. Programming, 33 (1985), pp. 300–317.
- [26] H. RATSCHKE AND J. ROKNE, *New Computer Methods for Global Optimization*, Ellis Horwood, Chichester, Halsted Press, New York, 1988.
- [27] J. ROHN, *Systems of linear interval equations*, Linear Algebra Appl., 126 (1989), pp. 39–78.
- [28] S. M. RUMP, *Solving algebraic problems with high accuracy*, in A New Approach to Scientific Computation, U. W. Kulisch and W. L. Miranker, eds., Academic Press, New York, 1983, pp. 51–120.
- [29] S. P. SHARY, *Optimal solution of interval linear algebraic systems. I*, Interval Computations, 2 (1991), pp. 7–30.
- [30] S. P. SHARY, *A new class of algorithms for optimal solution of interval linear systems*, Interval Computations, 2(4) (1992), pp. 18–29.
- [31] S. P. SHARY, *On controlled solution set of interval algebraic systems*, Interval Computations, 4(6) (1992), pp. 66–75.
- [32] S. SKELBOE, *Computation of rational interval functions*, BIT, 14 (1974), pp. 87–95.
- [33] M. ZAMANSKY, *Introduction a l'Algèbre et l'Analyse Modernes*, Dunod, Paris, 1963.