

Notes on Logic Circuits by LK

These notes introduce an interpretation of logic in terms of switching circuits. This application of logic to switching circuits is the discovery of Claude Shannon

A Symbolic Analysis of Relay and Switching Circuits. by Claude E.

The Journal of Symbolic Logic, Vol. 18, No. 4 (Dec., 1953), p. 347

and forms the basis for the design of computers to this day. Here is an abstract switch:

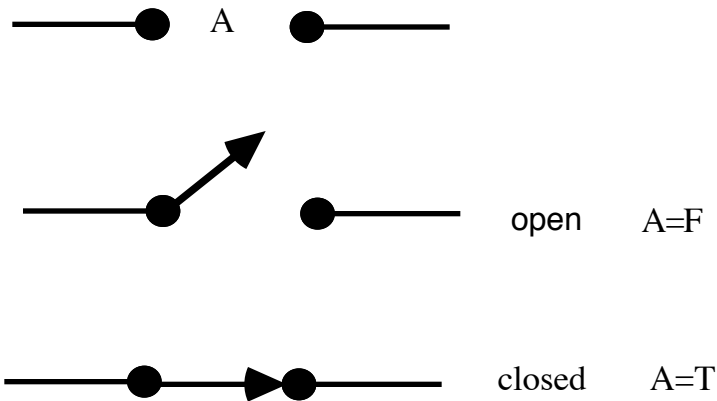

A signal can go from left to right through the switch when it is closed, and no signal can go through when the switch is open. We choose to designate a switch by a label such as A above and we let $A = T$ correspond to the closed switch position (T for "transmit" if you like!) and we let $A = F$ when the switch is in the open position ($F = \sim T =$ not transmit).

The position of a switch can control a device such as a lamp.

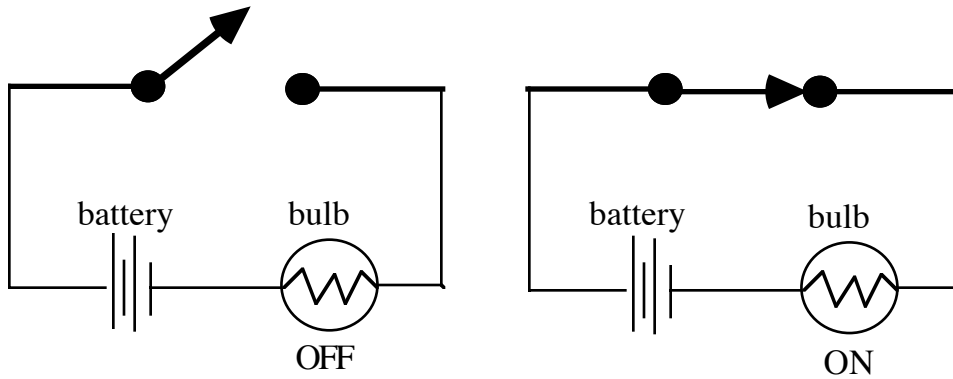

Two basic ways to put switches together are Series and Parallel Connection:



Series Connection: $A \wedge B$

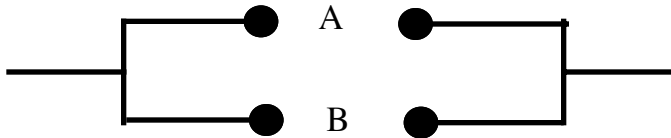

Parallel Connection: $A \vee B$

As you can see, the only way for a signal to get from left to right in the series connection of A and B is if both A and B are T (closed). Thus the series connection corresponds to A and B which we write in logic notation as $A \wedge B$.

Similarly, the only way for a signal to get from left to right in a parallel connection is if one of A or B is closed. Hence this corresponds to A or B, which we write as $A \vee B$.

Thus our two basic logical operations are mirrored in the behaviour of networks that carry signals.

What about negation? An example will show you how we handle this. What we do is, we allow multiple appearances of a given label or its negation. We will write either $\sim A$ or A' for the negation of A. Here we will use A' ok?

Then in the multiple appearances, all A's will be either closed or open and if you have A' and A is closed, then A' will be open. If A is open then A' will be closed. Look at this example:

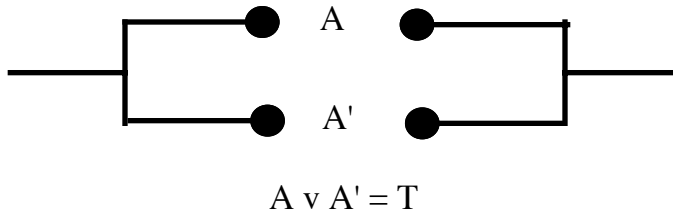
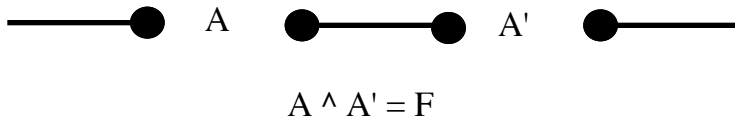

Each of these circuits has an A and an A'. In the series connection, this means that one switch is always open and so the value of the whole circuit is the same as a simple open circuit. On the other hand in the parallel connection of A with A' either one line will transmit, or the other line will transmit. So the circuit as a whole behaves like a single switch that is closed. Thus we see that the series connection corresponds to the identity $A \wedge A' = F$, while the parallel connection corresponds to the identity $A \vee A' = T$.

Terminology: Since a label A in one of our circuits can appear in many places we will still refer to A as a 'switch' even though it may be composed of a number of elementary switches. In such a multiple switch, if you make one, there has to be a mechanical way to make sure that all the different parts of the switch work together. Also these switching patterns may, in practice, happen in electronic circuitry that synchronizes actions at separate locations. For our purposes, we shall imagine simple mechanical switching devices.

Problem 1. Design a switching circuit with three switch labels a,b,c such that each of a, b and c individually control transmission of the signal. That is if the circuit is open, then changing the state of any one of a,b,c will close the circuit and if the circuit is closed, then changing the state of any one of a,b,c will open the circuit.

(We discussed how to do this with in analogous case of two labels and how it is related to $(a \wedge b) \vee (a' \wedge b')$ in class.)

Solution to Problem :

The logical condition for the three switches corresponds to the following settings

a	b	c
T	T	T
T	F	F
F	T	F
F	F	T

That is, we will have the line transmitting when all the switches are in the T-state, and whenever any two of them are flipped to the F state. This is expressed by the symbolic expression

$$E = (a \wedge b \wedge c) \vee (a \wedge b' \wedge c') \vee (a' \wedge b' \wedge c) \vee (a' \wedge b \wedge c').$$

This expression has corresponding circuit as shown below.

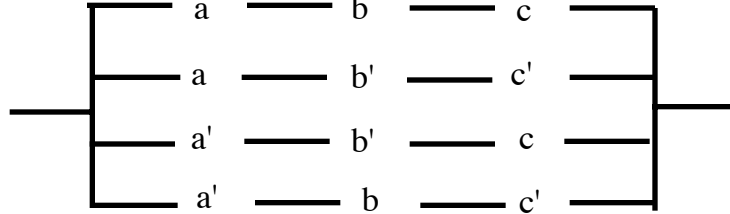

Now we face an interesting problem of simplification. The switches in this solution are a bit complicated, and it is clear that if we want to generalize to four or more switches that control one light, then this method will give us increasingly complex designs.

One way to search for simplification is to algebraically simplify the expression E. We can apply the distributive law $(a \wedge X) \vee (a \wedge Y) = a \wedge (X \vee Y)$ and reduce the number appearances of a and of a' in E. Then

$$E = a \wedge ((b \wedge c) \vee (b' \wedge c')) \vee a' \wedge ((b' \wedge c) \vee (b \wedge c')).$$

The circuit for this version of E is shown below.

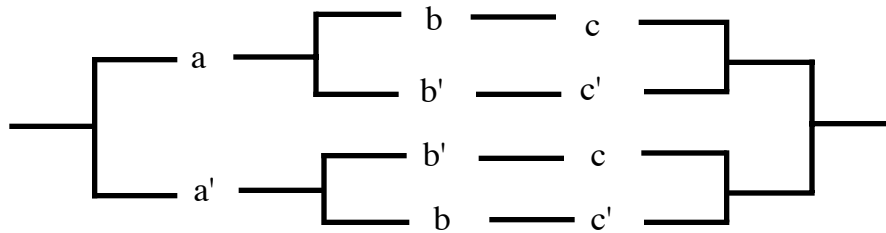

Now comes the subtle part! What we have just done suggests a corresponding modification on the right hand side of the circuit graph. We can clearly reduce to just one c and one c' on the right in same pattern by which we did it through the distributive law on the left. In order to do this, we will have to cross some wires in the circuit, and we shall understand that this does not mean that these crossed wires interact in any way as far as how they carry current. Here is a drawing of the result of the next simplification.

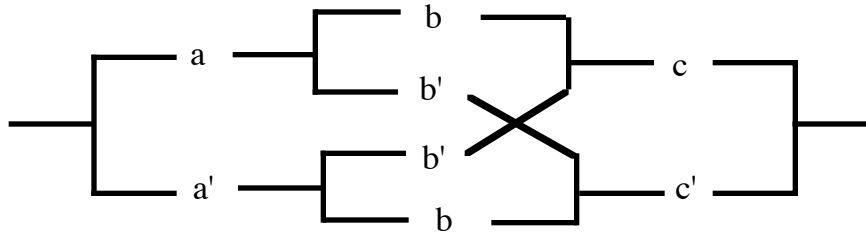

We have simplified the left and right switches as much as possible, and the middle switch has a really nice description if you look at it. When $b = T$ it corresponds to two parallel lines and when $b = F$ it corresponds to two crossed lines.

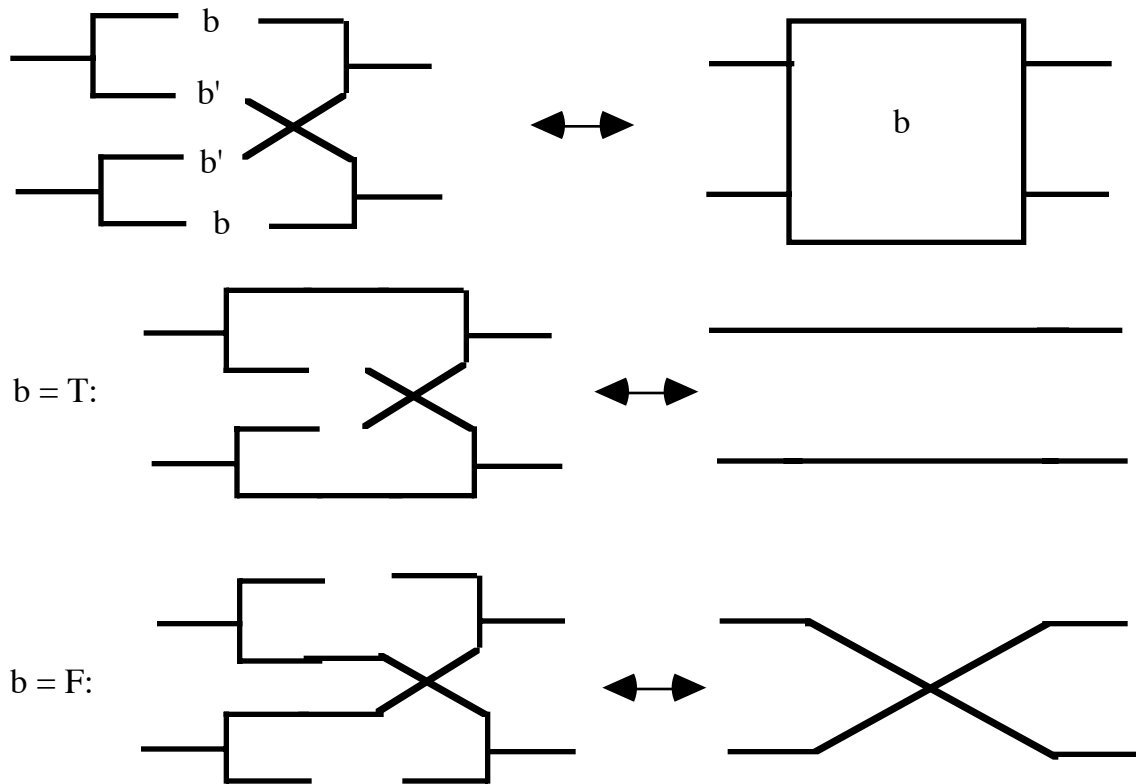

In the figure above we have indicated the middle switch by a box with the label *b*, and we have illustrated how the two states of the switch correspond to parallel and crossed lines. By simplifying the symbolic logic solution to the three switch light problem, we have invented a useful new switch. Lets call this switch, as shown above, the *crossover switch*.

I CLAIM THAT YOU CAN NOW MAKE USE OF THE CROSSOVER SWITCH, AND SOLVE THE PROBLEM OF DESIGNING A TRANSMISSION NETWORK THAT WILL CONTROL A SINGLE LIGHT FROM ANY ONE OF A SET OF N SWITCHES. ENOUGH HINTS. YOU SHOULD THINK ABOUT IT BY SEEING WHAT HAPPENS WHEN YOU CONNECT CROSSOVER SWITCHES TO ONE ANOTHER.

Problem 2. Generalize Problem 1. to an arbitrary number *N* of switch labels. That is, you would like to be able to control a single lamp with any one of *N* switches. You want to find a design that will work in principle for (say) a building with *N* floors, so that you can control the

entrance light from any of the floors. The switch on any given floor will turn the entrance light on or off. That switch on a given floor will have two positions just as our labels have two states T or F.