

SOKOINE UNIVERSITY OF AGRICULTURE



FACULTY OF AGRICULTURE

DEPARTMENT OF FOOD SCIENCE AND TECHNOLOGY

FT 101

LECTURE NOTES

BASIC ENGINEERING DRAWING AND COMMUNICATION

Inquiries, Suggestions, Opinions etc should be forwarded to:

Dr. Ballegu W R W or Dr. Mpagalile J J
Department of Food Science and Technology
Sokoine University of Agriculture
P O Box 3006, Chuo Kikuu
Morogoro, TANZANIA

Ext 4201 or 3112

FT 101: 2 Credit Hours: (30 Lect. hrs : 0 Sem. hrs : 60 Pract. hrs)

Prerequisite: None

Instructors: Dr. J J Mpagalile
Dr. W R W Ballegu (Mobile: 0754 463 016 ; E-Mail: wballegu@suanet.ac.tz)
Department of Food Science and Technology, SUA.

Objective: *To equip students with basic skills required in engineering drawings, electrical circuit diagrams, and communication.*

Course Contents: Purpose and forms of communication; technical communication, report writing, drawing, reprographics, engineering drawing, sketching, pictorial projections, paper sizes, scales, conventions in layout, lettering and representation of components, tolerances, assembly drawings, K-parts list, exercises in machine drawings, structural drawings and design.

Selection of machine components such as; V-belts, flat-belts and pulleys. Simple stress calculations for shafts and structural members.

Course Assessment: The Course Assessment (culminating to the Final Grade), will be made up of the following four components;

(i)	Weekly Practical Reports	---	20%
(ii)	Practical Tests	---	20%
(iii)	Theory Tests	---	20%
(iv)	End of Semester Examination	---	40%

COURSE OUTLINE

	PAGE
Part – 1: COMMUNICATION	5
1.1 Purpose and Forms of Communication	5
1.2 Technical Communication	5
1.2.1 Standardization	5
1.2.2 Technical Report Writing	6
1.2.3 Pictorial Communication	7
Part – 2 : ENGINEERING DRAWING	7
2.1 Presentation of Engineering (Technical) Drawings	8
2.1.1 Axonometric (Pictorial) Projections	8
Dimetric Projection	8
Isometric Projection	9
2.1.2 Orthographic Projections	9
Naming of Views	9
Standard Orthographic Projections	10
2.2 Standards	12
2.2.1 Paper Sizes and Folding	12
2.2.2 Scales	13
2.2.3 Lines and Lettering	14
2.2.4 Title Block and Parts List	16
2.3 Preparing Engineering Drawings	17
2.3.1 Sketches	17
2.3.2 Hand drafts	18
2.3.3 Detail (Working) Drawings	18
2.4 Preparing Detail Drawings	18
2.4.1 Some Basic Instruments and Equipment	18
2.4.2 General Guidelines	20
Spacing of Views	20
Projection of Views	21
2.4.3 Sectioning	22
2.4.4 Dimensioning	23
Functional Dimensions	23
Non-Functional Dimensions	23
Auxiliary Dimensions	23
2.4.5 Some Special Features	25
Threaded Parts	25
Machines Holes (Drilled and Milled holes)	26
Chamfers and Countersinks	27
Specially Treated Surfaces	27
2.4.6 Tolerances and Fits	27
2.5 Assembly Drawings	29
Part – 3: EXERCISES	30
REFERENCES	4

REFERENCES

1. STIRLING, N. (1989): *An Introduction to Technical Drawing – Metric Edition*
Delmar Publishers. Albany, New York, pp. 370
2. BHANDARI, V.K., BUEHLMANN, E.T., KELLER, U., OEHNINGER, J. and TOMESSEN, L.B.M. (1983):
Drawing and Design: Data Book for Mechanical Engineering
3. SHIGLEY, J.E. (1977): *Mechanical Engineering Design*
McGraw-Hill, Kogakusho Ltd, Tokyo
4. ORLOV, P. (1979): *Fundamentals of Mechanical Design – Vol. 1 – 5*
MIR Publishers, Moscow
5. FRENCH, T.E. and VIERCK, C.J. (1966): *Fundamentals of Engineering Drawing – 2nd Edition*
6. GIERSECKE, F.E., MITCHELL, A., SPENCER, H.C., HILL, I.L. and DYGDON, J.T. (1986):
Technical Drawing – 8th Edition
7. Any other Relevant Standard(s)
e.g. BS 303:164 Engineering Drawing Practice
Westermann Tables for the Metal Trade
BS 3763 The International System of Units (SI) etc.

Part – 1: COMMUNICATION

Definition: Communication is defined as, *"the act of communicating, that is, passing on news, information, feelings etc."* (Oxford Students' Dictionary of Current English – 1985)

1.1 Purpose and Forms of Communication

The purpose of communication – irrespective of the form/means in which it is conveyed – is to pass a message from one entity (a person or group of people) to another entity (person or group) in the most convenient way and with minimum distortion or ambiguity.

The two main forms of communication are through **audio** and **visual** means. Audio means rely on sound signals that are perceived by ears. Sound producing/receiving devices are used for this purpose. Visual means on the other hand, depend on light signals (images) that are perceived by eyes. Image producing/receiving devices are used for this purpose. This may include things like text, drawings, figures, photographs, video images, TV images, images of real objects etc. Other human senses are sometimes used for communication (e.g. a touch to attract attention, braille text for the blind, etc).

1.2 Technical Communication

Technical communication is an advanced form of communication whereby people of the same trade (profession) can convey messages to one another more accurately and precisely. To achieve this, a technical language, which is well standardized, is needed (e.g. botanical names for plant scientists, etc).

1.2.1 Standardization

Definition: *"Standardization is the process of formulating and applying rules for an orderly approach to a specific activity for the benefit and with the cooperation of all concerned, and in particular for the promotion of optimum overall economy taking due account of functional conditions and safety requirements."*
(ISO – International Organization for Standardization)

Standards are set at different levels. There are local standards, national standards, regional standards and international standards. Typical examples of the different levels of standards may include;

- **Local Standards:** SUA formats for writing various academic reports, Morogoro Municipal standards for waste disposal, grading of product quality in an industry, etc.
- **National Standards:** All TBS standards, standards set by local professional bodies e.g. the Engineers' Registration Board (ERB), DIN (German), BS (U.K.), GOST (U.S.S.R.), etc.
- **Regional Standards:** Standards set for the East African Community, standards for the SADC region, even the AU can set standards for her member states, etc.
- **International Standards:** ISO (International Organization for Standardization)
 - DIN – an internationally accepted German national standard
 - BS – an internationally accepted British national standard

It is always desirable to adhere to international standards, particularly the ISO standards that employ SI units. Standardization serves five main objectives;

- Creation of uniform terminology
- Maintenance of a limited order of variety
- Specification of functional uses and limitations
- Establishment of unambiguous objective test methods and material specification
- Conduction of comparative studies of various standards

1.2.2 Technical Report Writing

Reports are written in accordance to accepted standards (formats). There are some minimum requirements, which the report has to satisfy for it to be accepted. In any report, a minimum number of words – which sufficiently presents the message accurately and precisely – is needed.

Requirements for different reports vary. For instance, educational reports (e.g. laboratory practical reports), reports for seminars and workshops, research reports, research findings for publication in reputed scientific Journals, etc. Despite the many variations in the formats of reports, almost always a technical report consists of the following parts; Abstract, Introduction, Literature Review, Materials and Methods, Experimental Setup, Results, Discussion (often times, the results are combined with discussions), Conclusions and Recommendations, References and Appendices. It must be noted that this is only a general guideline and not a "*strict biblical command*". In real life, there is likely to be some minor (or even major) variations. As a rule of thumb, any technical report must be styled and detailed to focus on the intended reader(s). For instance, a report intended for a village meeting will differ significantly in style and level of detail from a research paper intended for publication in a scientific Journal.

- **Abstract**

This is a brief summary (150 – 300 words) of the work being reported. It is simply a synopsis of *what was done, why, how, the main findings, the main conclusions and/or recommendations*. Although the abstract appears first in the report, it is usually written last after everything has been put in place. Usually this is the most difficult part of the report to write, as it has to reflect in a nutshell the rest of the report!

- **Introduction**

This is the background information (briefly) justifying the work being reported. It is a synopsis of *what has been done prior to the present work (reference to the literature), strengths and weaknesses of the methods used in the past and what has been done in the present work that distinguishes it from the past works*.

- **Literature Review**

This presents a detailed coverage of what others have done that is closely related to the present study. This has to reflect the scope of knowledge (most updated) that is reported in the literature related to the work being reported in the present study. *It forms a sound basis for meaningful interpretation of the results obtained in the present study*.

- **Materials and Methods (Methodology)**

The materials used (sources and quality/grade), methods used (briefly explain each method in detail to enable the reader to replicate your work, if deemed necessary. *For standard methods, make reference to the standard(s) concerned (e.g. AACC-----), a brief account of how non-standard experiments were done is usually necessary*.

- **Results and Discussion**

This part is normally presented in tabular and/or graphical forms. It is a *brief discussion of main findings based on the results obtained and experience of other workers (literature)*. Sometimes the results are presented separate from the discussion.

- **Conclusions and/or Recommendations**

Your personal inferences regarding the results, your recommendations for further work, etc. You should be honest and admit main weaknesses that might have affected the results obtained in your reported work (i.e. main sources of error – if any).

- **References**

All sources of information cited in the literature review and elsewhere. Avoid including general reading materials that were used to obtain a general background on the subject matter.

- **Appendices**

Any relevant information, which you strongly feel is necessary for the wholesomeness of the report, but which could not be conveniently fitted into the bulk of the report.

1.2.3 Pictorial Communication

Pictorial communication includes drawings and photographs. Drawings and photographs, where appropriate, convey the message more accurately than a passage of words. Photographs are more accurate and sometimes the true colors of the object are displayed. However, photographs are expensive, less informative and their magnification is limited in terms of clarity. On the other hand, drawings are cheap, clearer and easy to understand. They are therefore, in most cases, more preferred than photographs.

Part – 2: ENGINEERING DRAWING

Why Engineering Drawing?

As a Food Scientist and Technologist, you will inevitably be required to communicate with different people for different reasons. In some situations, communications will be sufficiently taken care of by use of plain text. However in other situations, text alone may not suffice and a more specialized form of communication (technical/engineering drawing) may prove irreplaceably useful.

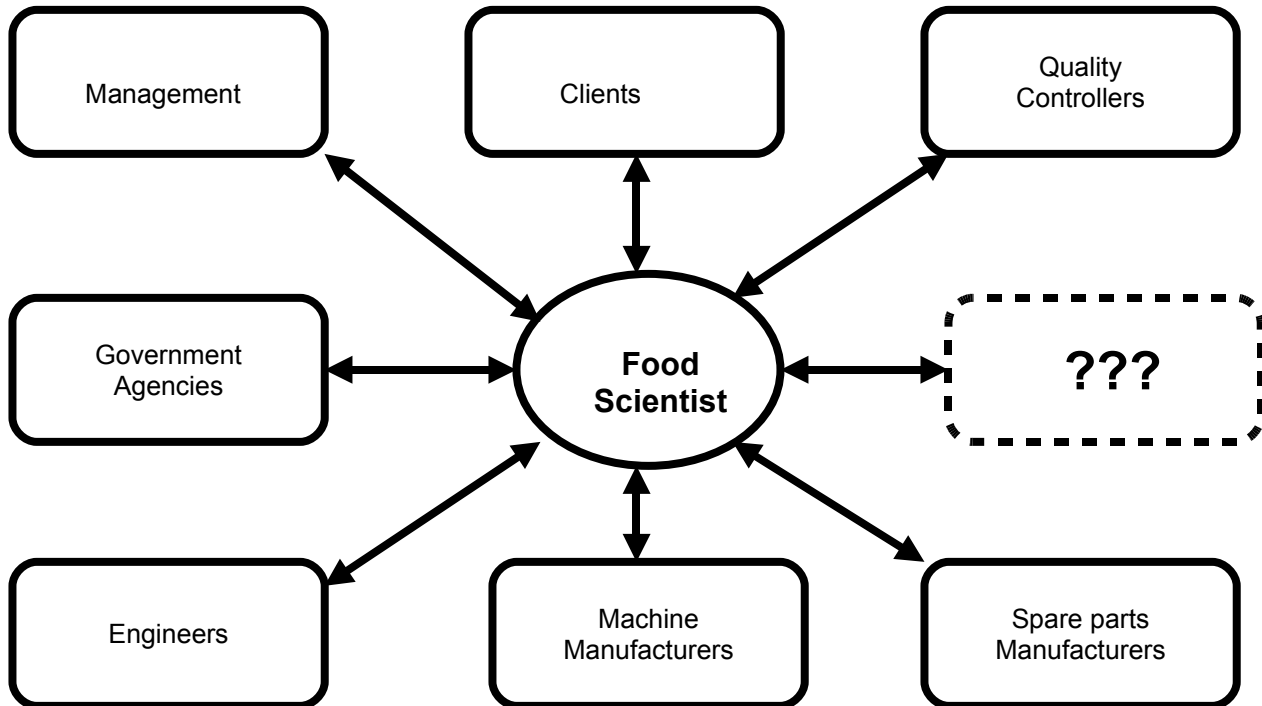

Drawing (just like photography) is one of the basic forms of visual communication. Drawing is used to record objects and actions of everyday life in an easily recognizable manner. There are two major types of drawings: *artistic drawings* and *technical drawings*.

Artistic Drawings

These are a form of freehand representation that makes use of pictures to provide a general impression of the object being drawn. There are no hard rules or standards in the preparation of artistic drawings. They are simply drawn by artists, based more or less on one's talent and skills. Although these drawings are often very attractive, they find very limited use in the world of science.

Technical Drawings

These are detailed drawings drawn accurately and precisely. They are pictures that have been prepared with the aid of mathematical instruments in order to record and transmit technical information. They provide an exact and complete description of things that are to be built or manufactured.

- Technical drawings do not portray the objects the way they directly appear to the eye
- They make use of many specialized symbols and conventions in order to transmit technical information clearly and exactly.
- To understand and correctly interpret technical drawings, one needs to acquaint oneself with the fundamentals of technical drawing – hence the purpose of this course.

2.1 Presentation of Engineering (Technical) Drawings

2.1.1 Axonometric (Pictorial) Projections

These are drawings in which the object is drawn in three dimensions (3-D), i.e. three sides of the object appear in one drawing. Normally only one drawing is prepared/used.

- They are used extensively in artistic drawing.
- A three dimensional view (i.e. shows length, width and height of the object simultaneously)
- Provides only a general impression of the shape of the object by allowing the observer to see three of its sides as well as its three overall dimensions
- An exact and complete description of its shape, particularly as applied to its slots on the underside is lacking.

Two standards are currently used for axonometric projections: *dimetric projection* and *isometric projection*.

Dimetric Projection

In dimetric projection, all dimensions along two axes are drawn to TRUE SIZE. The dimensions along the third axis are HALVED. This projection is preferred when one view of the object is to be emphasized than the other two views (i.e. when that one view is of more interest than the other views).

Example: A cube of length L

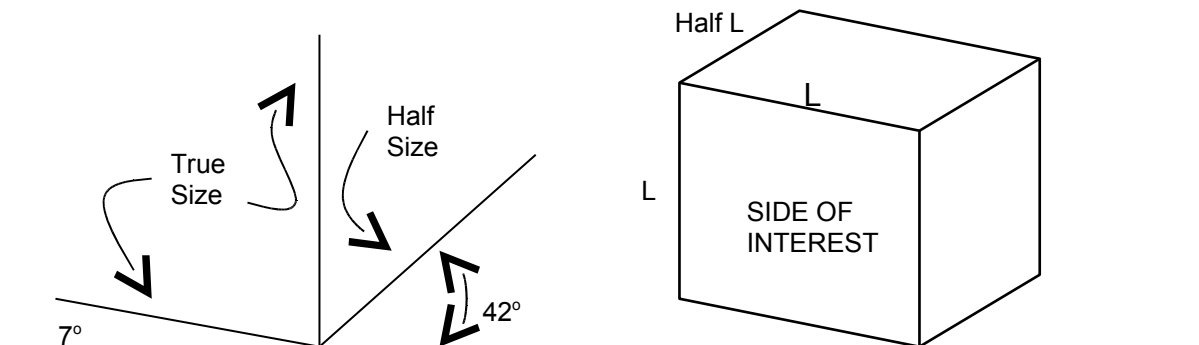

Isometric Projection

In isometric projection, all dimensions along all the three axes are drawn to TRUE SIZE. Isometric projection is preferred when the three views of the object are of equal importance for accurate presentation of the object.

Example: *Cube of length L*

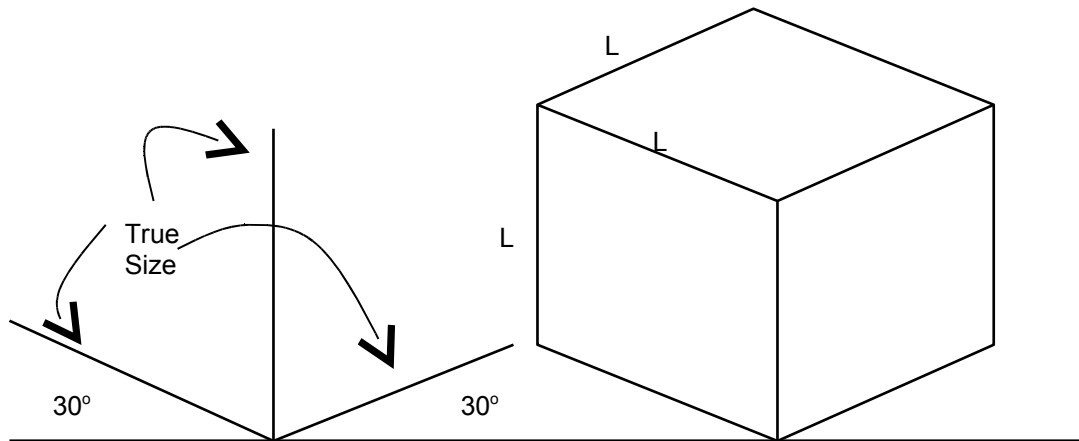

2.1.2 Orthographic Projections

To present an object in a unique way, generally more views (and sometimes sections) are required. In orthographic projection, the views are seen in directions that make right angles (i.e. 90°) with each other. The number of views needed should be sufficient to represent the object completely and conveniently, but it should be kept to the minimum. *For most purposes, three views are usually sufficient.*

- Engineering (Technical) drawings usually utilize orthographic views (OV) rather than pictorial views
- Orthographic (OV) help to record the shapes of objects exactly and completely
- OV is a two-dimensional (2-D) drawing. It shows only one side of an object and two of its overall dimensions
- A minimum of two OV is required to show the three dimensions of any object and therefore to describe its shape completely

Some features of the object that do not directly appear on viewing the object from any specific direction (known as *hidden details*) are shown on the drawing as dotted lines.

Naming of Views

In orthographic projection, three views are normally drawn. The three chosen views may be any of the six hypothetical faces of the object. These views are named as shown below.

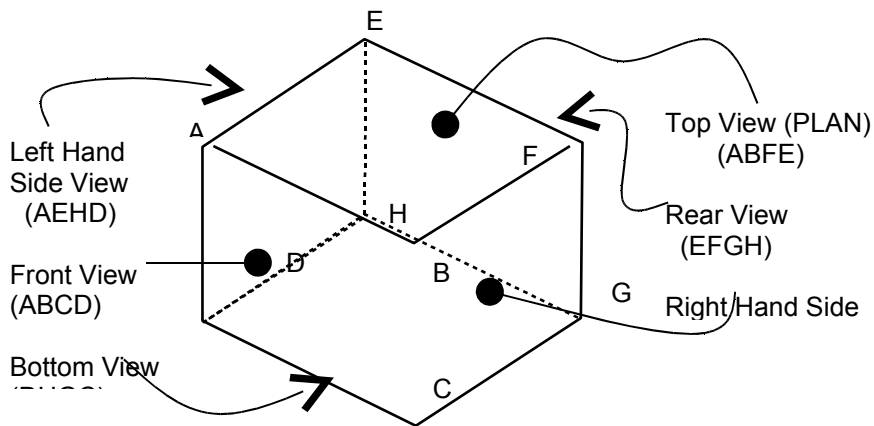

The Front View (ABCD) – abbreviated as FV, is that view of utmost importance in representing the object (normally the most complicated of all the views) as seen when the object is placed directly in front of the viewer. This view generally serves to represent the object (e.g. a work piece) in the most common position in which it is used. It is normally the first view to be drawn – other views following thereafter. The Rear View – RV (EFGH) is directly opposite the FV at the back of the object. The Right Hand Side View – RHSV (BFGC) and the Left Hand Side View – LHSV (AEHD) appear on the right and left sides of the object, respectively. The Top (ABFE) and Bottom (DCGH) Views are at the top and bottom sides of the FV. As you must have noted, these six views are at right angles to one another.

Standard Orthographic Projections

Two standards are commonly in use in orthographic projection of drawings; the *First Angle Projection* (European projection) and the *Third Angle Projection* (American projection). It should be noted that corresponding views are identical in both methods of projection except for their relative positions on the drawing paper.

The First Angle Projection

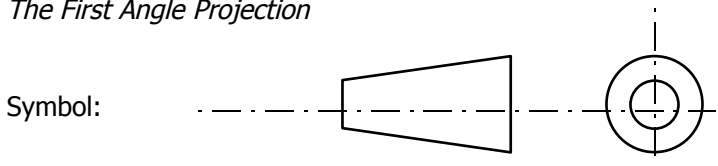

In here, the front view (A) is the basis (reference) and the other views are drawn as '*shadows*' of that view. That is, the left hand side view for instance is drawn on the right side of the front view. Similarly the top view (plan) is drawn at the bottom of the front view, etc.

The Third Angle Projection

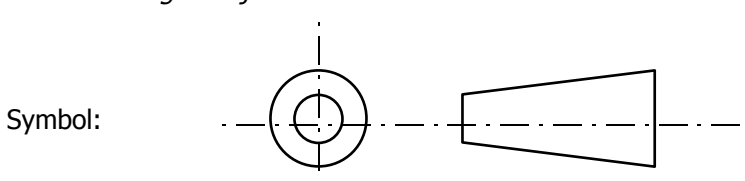

In here, the front view is the basis (just as before) but the other views are drawn as '*reflections*' of that view. The left hand side view is drawn on the left hand side of the front view. Similarly, the top view (plan) is drawn at the top of the front view.

Example: The Front View (FV), Left Hand Side View (LHSV) and Top View (PLAN) of the given object

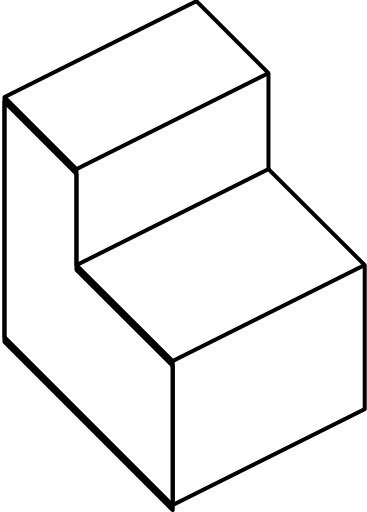

SOLUTION – I

First Angle Projection

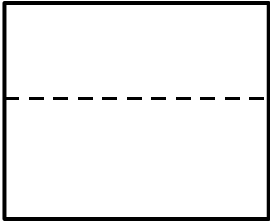
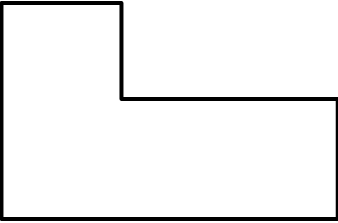

SOLUTION – II

Third Angle Projection

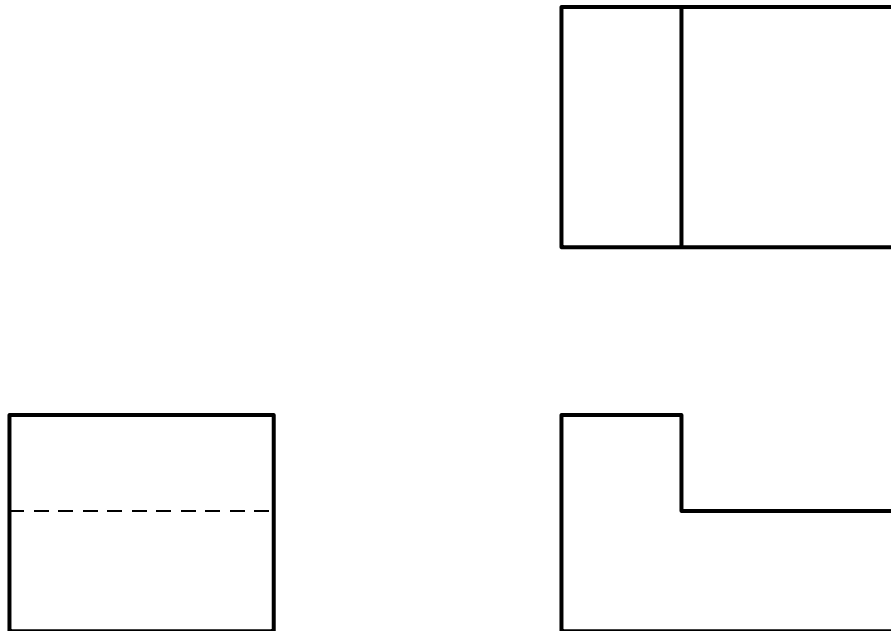

2.2 Standards

Engineering drawings, being one of the many forms of technical communication, have to fulfill some accepted standards. There are various national, multinational and international standards, but the current trend in most countries is to adhere (adopt) the ISO standards. Thus for the purpose of this course, we will adhere to the ISO standards.

2.2.1 Paper Sizes and Folding

The ISO most recommended paper sizes for technical drawings are known as **A-FORMATS**. Other series, like the B-Series, are of lesser importance. In the A-Format series, the largest size is A0. The size of an A1 paper is half the size of A0 while A2 is half the size of A1 and so forth. Note that a higher order paper size (which is always smaller in size) is obtained by simply halving the preceding size along its longer side. For technical drawings A4 is considered to be the smallest paper size. Smaller-sized A-Format papers (i.e. A5, A6, etc) are very rarely used for technical drawings.

The A-Format Paper Sizes

Format	Cut (mm)	Sheet
A0	841 X 1189	
A1	594 X 841	
A2	420 X 594	
A3	297 X 420	
A4	210 X 297	
.....	

NOTES:

(i)

When a format smaller than A4 is needed, it is obtained by simply halving A_n along its longer side. For instance A5 has 210-mm as its longer side and $(297/2 = 148\text{-mm})$ as its shorter side.

- (ii) Format A4 is exclusively used in an upright position. The other formats (which are larger in size than A4) may be used in an upright position or horizontal position.

Folding

Only format A4 is convenient for filing. Other formats (larger in size) exceed the size of the file and thus must be folded before filing. Drawings which that do not need fastening are fold in a logical way to give an A4 size. However, for those drawings that must be fastened, they must be be fold in a standardized way as follows.

Format A1 --- (594 X 841 mm)

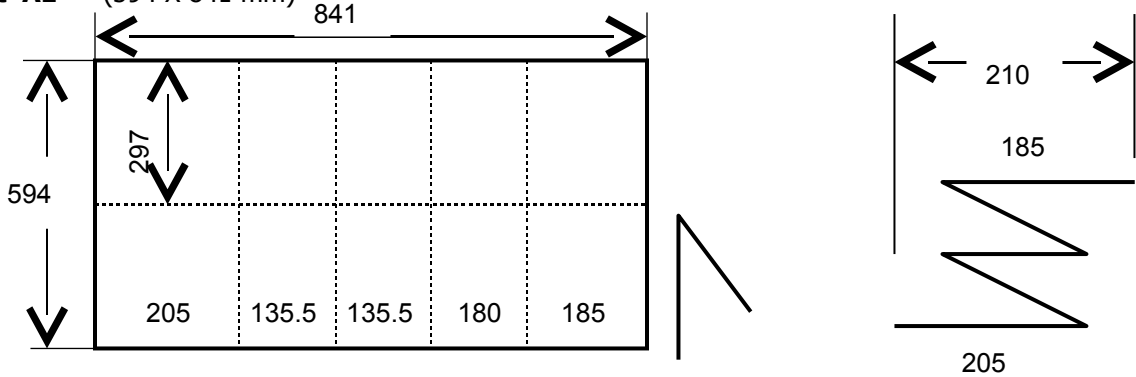

Format A2 --- (420 X 594 mm)

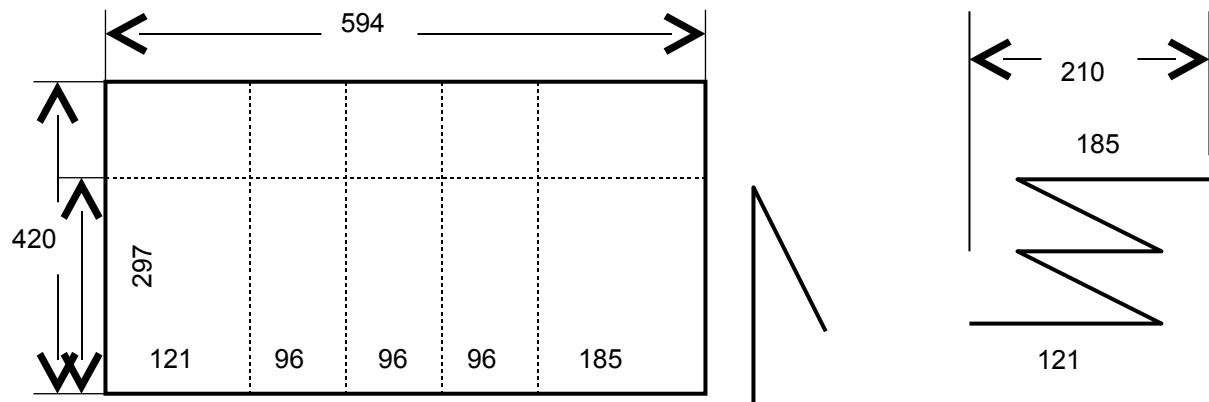

2.2.2 Scales

The objects we encounter in our day-to-day life are usually either too large or too small to be drawn to their true size. For instance a car or a building can be drawn to its true size if, and only if, we use a piece of paper that is large enough to accommodate the true dimensions of that car or building. But as we have noted above, the largest size of paper (under ISO standard) is A0 (841-mm X 1189-mm), which is a lot smaller than these objects. The discrepancy between the actual sizes of objects and the size of the papers we use for drawing necessitates us to prepare drawings that are either smaller or bigger in size than the actual objects. This is only possible through the use of scales.

- A scale is simply the ratio of the linear dimension appearing on the drawing compared to the corresponding linear dimension on the object
- A scale has no units as it is simply a ratio (i.e. **dimension on drawing : dimension on object**)
- Scales are used either for enlargements or reductions

The recommended scales in Engineering Drawing are





True Size	1:1		
Scales for Reduction	1:2 1:20 1:200	1:5 1:50 1:500	1:10 1:100 1:1000
Scales for Enlargement	2:1 20:1 200:1	5:1 50:1 500:1	10:1 100:1 1000:1



The scale of 1:1 (read as one-to-one) implies the object has been drawn to true size. A scale of say 2:1 (read as two-to-one) implies that the object has been enlarged twice its true size. A scale of 1:2 (read as one-to-two) implies that the object has been reduced to its half size, etc.

2.2.3 Lines and Lettering

Lines

In Engineering Drawing, we make use of different lines and line styles to convey the desired message. These lines differ in (i) *thickness* and (ii) *style*. Typical uses of these lines are summarized below.

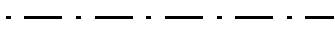
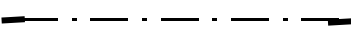
Type of Line and Designation	Applications	Recommended line thickness [mm]	
		PAPER SIZE	
		A4/A3/A2	A1/A0
A:  A continuous thick line	1. Object line	0.5	0.7
B:  A continuous thin line	1. Dimensioning line 2. Projection or extension lines <i>(used to project points from one view to another)</i> 3. Hatching 4. Outlines of adjacent parts 5. Outline of revolved views or revolved sections 6. Leaders for notes 7. Imaginary outlines	0.25	0.35
C:  A continuous wavy line	1. Break line of part views and part sections when break lines are not center lines	0.25	0.35
D:  A short thin dashes	1. Non-visible outline (hidden) <i>(3 – 4-mm strokes, 1 – 2-mm spaces)</i>	0.25	0.35

<p>E:</p>  <p>A thin chain line</p>	<ol style="list-style-type: none"> Center lines and pitch circles path lines for indicating movement and/or extreme positions oulines positioned in front of a section Folding edges in developments 	0.25	0.35
<p>F:</p>  <p>A thin chain line with thick extremities</p>	<ol style="list-style-type: none"> Cutting or viewing planes 	0.5/0.25	0.7/0.35
<p>G:</p>  <p>A thick chain line</p>	<ol style="list-style-type: none"> indication of surfaces with supplementary or different treatments 	0.5	0.7

Hidden Lines

- Each end of a hidden line should touch the object line

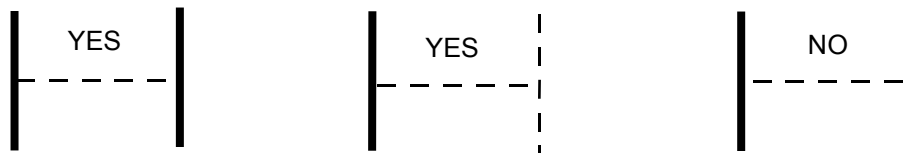

- A hidden line should not touch an object line if it is an extension of the surface the object line represents

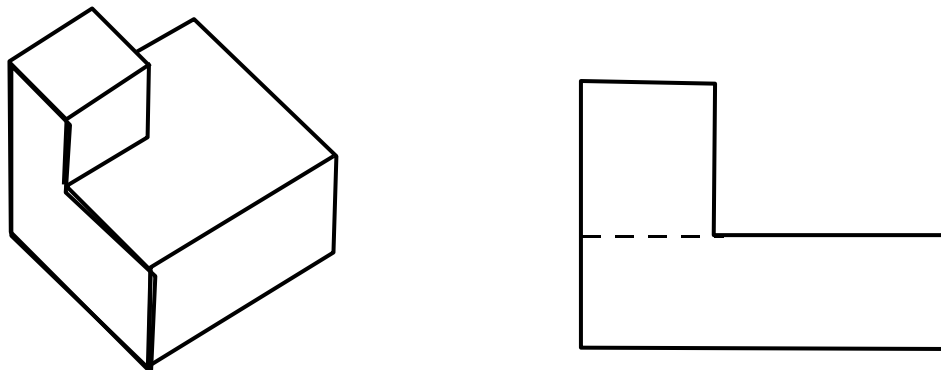

- The strokes of parallel hidden lines that are relatively close together should be staggered



- Corners of hidden lines should be solid

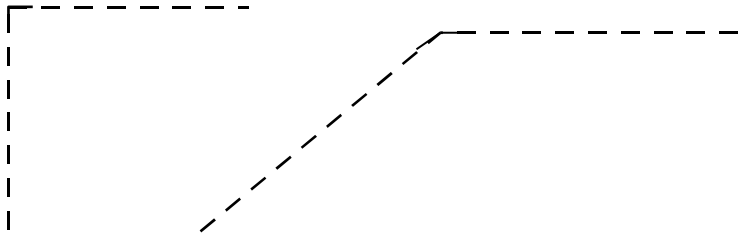

Lettering

Lettering used in engineering drawing is referred to as a ***Single Stroke, Commercial Gothic***. The main advantage of this font is that it is easy to read. This makes the information on engineering drawing easy to understand. The letters can be made either freehand or by use of lettering devices. The general construction of vertical gothic letters and numerals is shown below (next page).

Hints on Lettering

- To save time, use a guide lining device
- The recommended height of lettering is 3-mm
- During initial learning period, make a point of concentrating on hand control
- Endeavor to make your hand do what you want it to do and not otherwise. Remember your fingers are not used to such movements, so they have to be trained until hand control becomes effortless
- Do not guess at the construction of letters and numerals. Use the sample letter
- Make letters and numerals as wide as they are high with individual letters of a word almost touching
- Spacing between words is a matter of judgment and tends to improve with practice
- Lines of lettering should be spaced the same distance apart
- Do not attempt to erase guide lines after lettering has been completed

A	B	C	D	E	F	G	H	I	J	K	L	M
a	b	c	d	e	f	g	h	i	j	k	l	m
N	O	P	Q	R	S	T	U	V	W	X	Y	Z
n	o	p	q	r	s	t	u	v	w	x	y	z
0	1	2	3	4	5	6	7	8	9			

Font: Square721 BT **Font Size:** 15

2.2.4 Title Blocks and Parts Lists

Title Block

In every engineering drawing, a Title Block is included at the bottom right-hand corner. The Title Blocks are locally standardized but should be designed in such a way that it can be easily understood. The information needed in any standard Title Block is normally:

- Name of the Firm/School/College
- Name of the Object (Work piece)
- Number of the drawing (particularly useful for reference where more than one drawing are concerned --- typically in assembly drawings)
- Format of the paper used (paper size)
- Scale used
- Dimensioning unit (usually millimeters --- mm)

- Symbol for the method of projection used
- Date when the drawing was finished
- Name of the draftsman (draughtsman) --- e.g. student name if it is a normal class exercise
- Name of the person who checked the drawing
- Remarks

The Title Block used at the then Faculty of Engineering (University of Dar es Salaam) is shown below. For the purpose of this course, we will adopt the same.

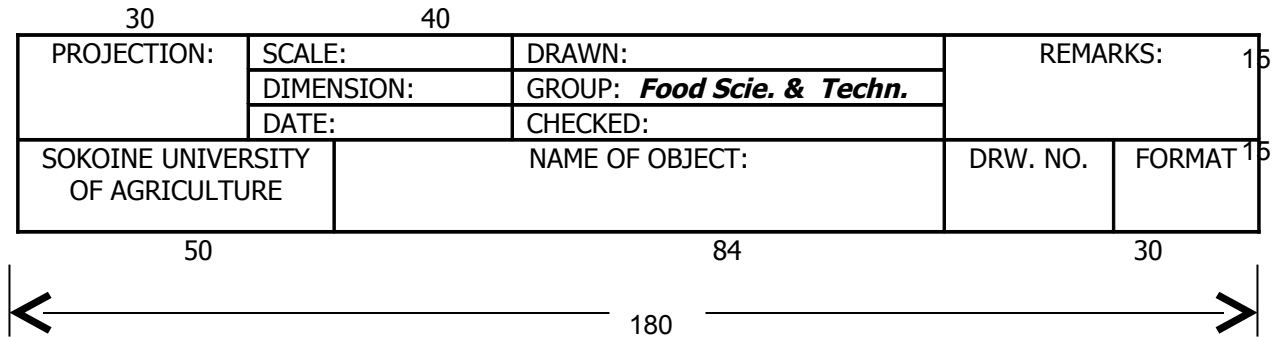

Parts List

The Parts List is an essential component in any assembly drawing. It is usually drawn on top of the Title Block. The Parts Lists usually have the same width as the Title Block, i.e. 180-mm. The height depends on the number of items to be included. The following information is usually included in the Parts List;

- A --- Part reference number
- B --- Name of the part
- C --- Number of parts required in an assembly
- D --- Material used to manufacture the part
- E --- Indication of standard or dimension
- F --- Drawing number

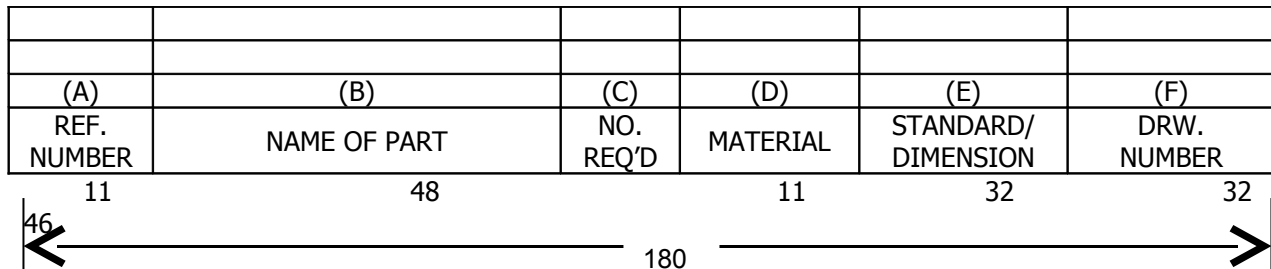

2.3 Preparing Engineering Drawings

Usually engineering drawings (of real life objects) are prepared in three stages; sketches, handdrafts and detail drawings. This sequence is not very binding but most workers find it very useful to work in that order.

2.3.1 Sketches

Sketching is almost always the first step in the preparation of Engineering Drawings (ED). The work piece (object) is carefully studied and all the necessary dimensions are measured. The views that are necessary to completely describe the object are very roughly drawn (free hand). All dimensions are

indicated on the sketch as deemed necessary. In most situations, axonometric views of the object are drawn. Sketches are never submitted anywhere. They are just drawn to assist you at a later time when preparing standard drawings. That is, the only purpose of preparing sketches is to enable you to transfer useful information from the spot to a convenient place where you can actually prepare acceptable EDs. For this reason, there are no hard rules or general guidelines with respect to sketches. Nevertheless, sketches should be drawn accurately so that they may prove useful at a later stage.

2.3.2 Hand Drafts

Hand Drafts are actually proper ED drawn free hand. The similarity between a sketch and a hand draft is that they are both drawn free hand. But unlike sketches, hand drafts are drawn following all the rules and guidelines governing EDs. Hand drafts are drawn roughly to scale and all the necessary dimensions are indicated. Only those views, which are necessary to completely describe the object, are presented. The hand draft is then given to the draftsman who "copies" the same into a proper ED. This ensures that the draftsman produces an ED in exactly the same way as you want it to appear. In short, a hand draft saves you time and effort that you will otherwise need to prepare a proper ED, hence enabling you to leave the later exercise to a draftsman.

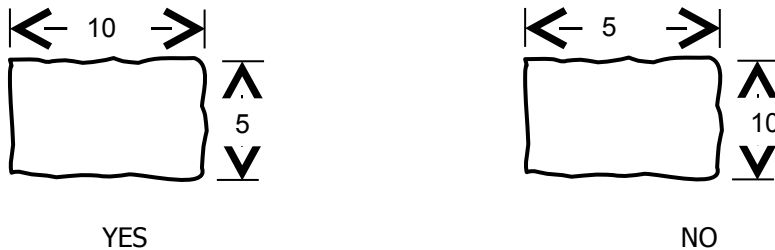

2.3.3 Detail (Working) Drawings

Detail drawings (also known as working drawings) are EDs presenting single items (object/machine component/work piece etc). They are meant to enable the person in a workshop to produce (by machining/casting/forging/fabricating etc) the desired item. Such details as dimensional tolerances, surface finish, special treatments, material to be used for the component etc are specified. The number of views to be presented depends on the complexity of the item. In many situations, sectional views are included to show hidden details that could not conveniently and explicitly appear in any external view. The scale used for the detail drawing should allow a clear understanding of the drawing (i.e. use enlargements and/or reductions as you find it appropriate). Sometimes just a small portion of the drawing is enlarged to show all the details. Such partial enlargements are normally included in the same drawing. When the item is drawn much enlarged, it is recommended to add a picture (drawing) to true size for more information.

2.4 Preparing Detail Drawings

2.4.1 Some Basic Instruments and Equipment

Detail Drawings are prepared with the aid of special instruments and/or equipment. It would have been extremely difficult for most people to prepare EDs according to the required standards/specifications without the aid of such instruments. The following are the basic drafting tools worth understanding:

- i) T-Square
 - ◆ This is one of the oldest drawing instruments that still finds wide spread use both in the industry and in schools.

- ◆ The size of a T-Square is determined by its blade length. Blade lengths of 60-mm, 90-mm, 120-mm and 150-mm are common.
- ◆ USES: + The T-Square is used primarily as a guide for drawing horizontal parallel lines.
 - + It can also be used when drawing inclined lines, just like any other rule.

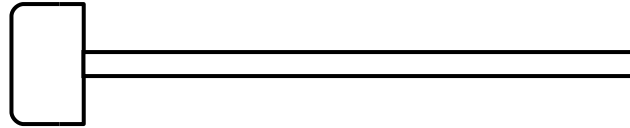

ii) Parallel Rule

- ◆ This is a straight edge that is permanently mounted on a drawing board or drafting table by means of pulleys and guide ropes.
- ◆ It enables us to draw horizontal lines quite fast.

iii) Set Square

- ◆ Set Squares (SSs) are transparent, triangular-shaped drawing instruments that are used with either a T-Square or parallel rule for drawing vertical or inclined lines.
- ◆ SSs contain angles most commonly used in technical drawing, i.e. 30°, 45°, 60° and 90°.
- ◆ The height/length of SSs is typically 15-cm, 20-cm, and 25-cm.

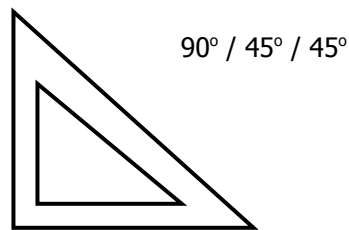
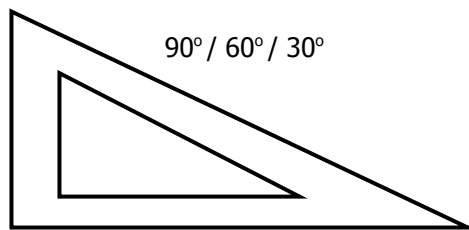

iv) Drafting Machine

- ◆ This is a machine/device with two scales set at right angles to one another.
- ◆ It can be moved easily and quickly to any location on the drawing surface.
- ◆ The edges of the scale are used for measuring as well as for drawing.

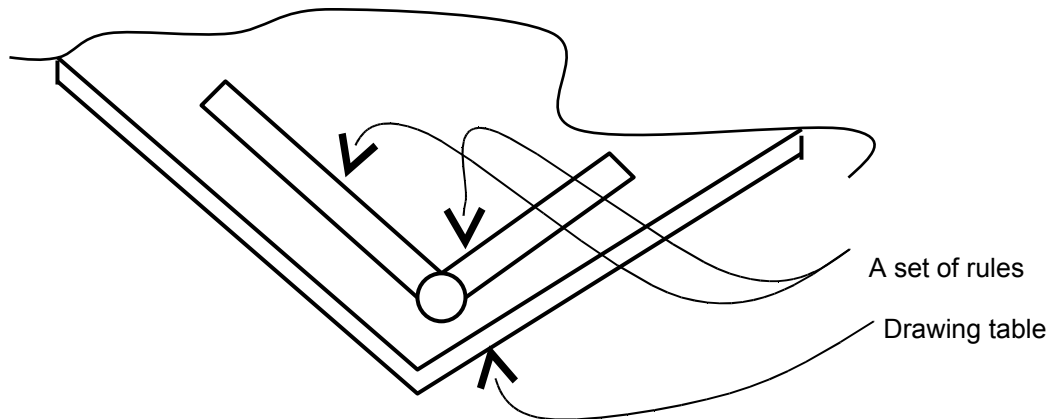

v) Rule Scale

- ◆ This is a measuring instrument and should not be used to draw line
- ◆ They are available in flat and triangular styles. The triangular style is more common in schools
- ◆ They can be used to prepare drawings to: full scale (true size, reduced scale and enlarged scale)

vi) Wooden Pencil

- ◆ Pencils in general (including wooden pencils) are graded depending on the degree of hardness. They include;
 - + hard range (e.g. hard black --- HB) which are used for accurate layout work
 - + medium range --- for general drawing and sketching
 - + soft range --- used exclusively for art work

vii) Mechanical Drawing Pencils

- ◆ These are simple, efficient drawing aids that consist of an outer and gripping housing which hold the lead.
- ◆ Only the lead wears out while the housing remains intact
- ◆ For the same housing, you may use leads of different hardness depending on the duty at hand

viii) Erasing Shield

- ◆ This is a very thin plastic (or metal) instrument that has a number of holes of various shapes and sizes on it
- ◆ The shield permits erasure to be made within confined areas of a drawing, other information remaining in place

2.4.2 General Guidelines

Spacing of Views

Spacing of views on the drawing paper is extremely important. The general appearance of the drawing is significantly affected if the different views are poorly spaced. Spacing of views requires us to place the views on the drawing paper such that the spaces between the views and between the views and the limits of the drawing space are roughly equal (horizontally and vertically).

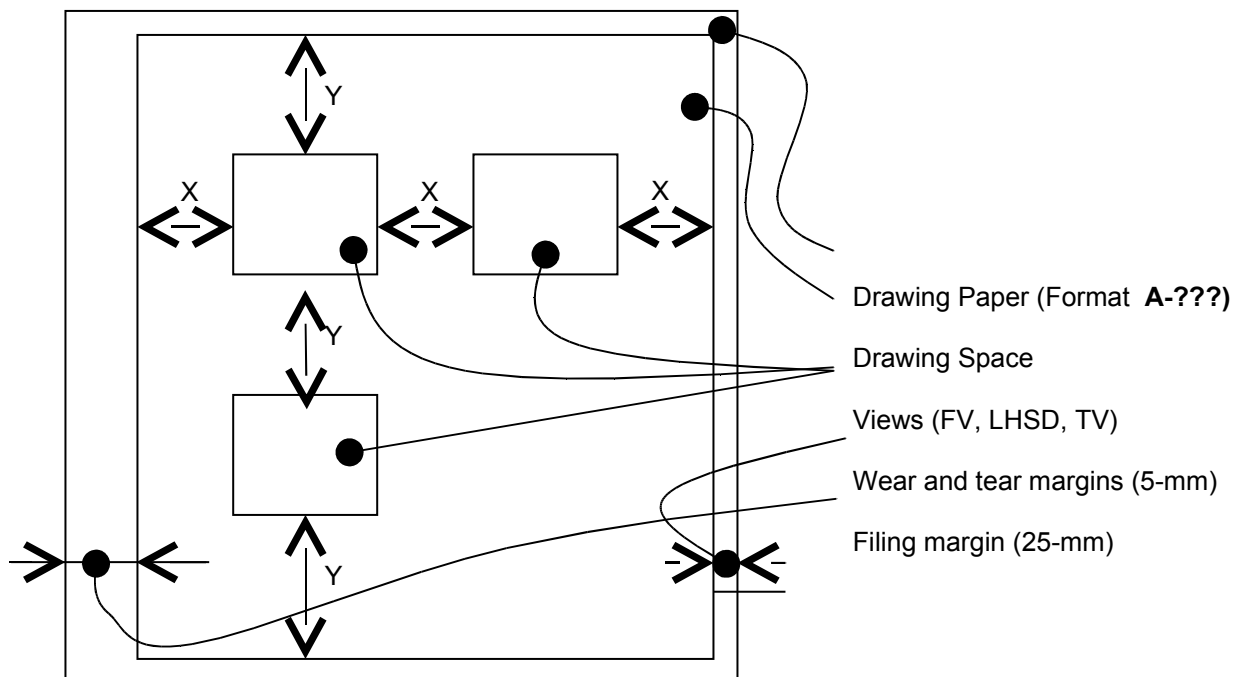

Steps

1. Decide on the views to be drawn (i.e. FV, LHSV and TV)
2. Determine the extreme dimensions of the different views to be drawn

3. Determine the required space, based on the scale to be used, both along the horizontal and vertical directions
4. Divide the "free space" into three equal portions, both horizontally and vertically. This will give you X and Y

EXAMPLE: *Horizontal Spacing.*
 Object Size (a-mm X b-mm X c-mm)
 Drawing Space (horizontal = d-mm)

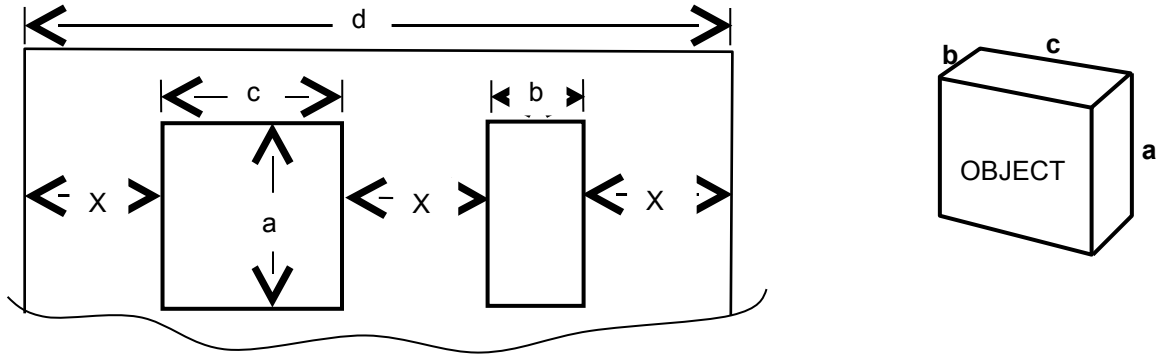

$$\text{Horizontal Free Space} = (\text{Horizontal Drawing Space}) - (\text{Occupied Space}) = d - (c + b)$$

$$X = (\text{Horizontal Free Space}) / (\text{Number of Spaces}) = \{d - (c + b)\} / 3$$

Projection of Views

As pointed out earlier, for most cases, three views are sufficient to completely define the component (i.e. Front View --- FV, Left Hand side View --- LHSV, and Top View (Plan) --- TV). When drawing these views, one may start with any view. However the common practice is to start with the FV. Once the first view has been correctly drawn, with all the dimensions correctly measured, the second view is drawn much faster by *projecting* (i.e. transforming) most of the dimensions from the first view. The third view is drawn without taking any new measurements. The use of specially designed drawing facilities (e.g. a drawing table, a T-Square, set Squares etc, or drafting machine) simplifies this task.

EXAMPLE:

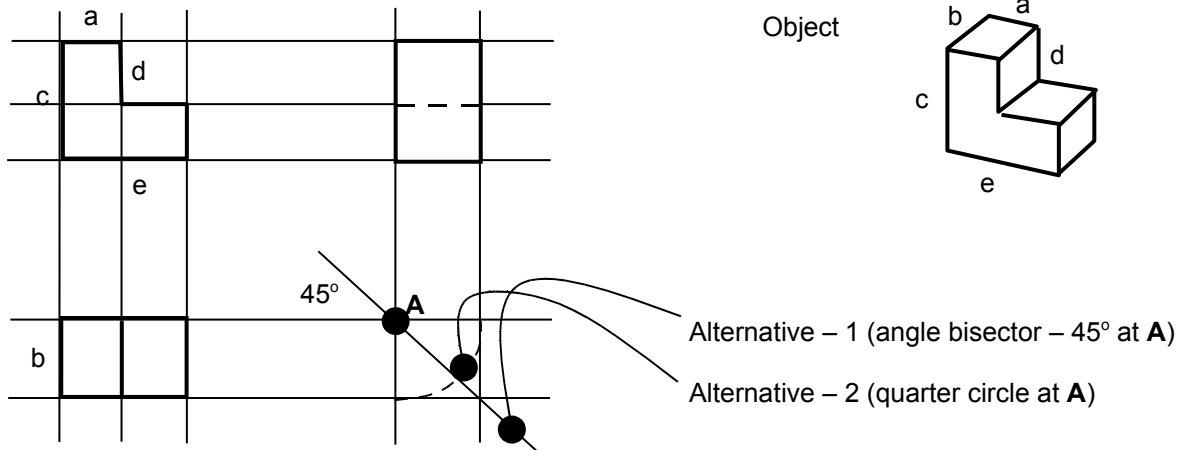

2.4.3 Sectioning

For complex components with a number of hidden details, external views may not be enough to enable machining of such components. In such cases, sectioning is recommended.

Sectioning is achieved by assuming an imaginary cutting/sectioning plane (or several planes) passing through the detail of interest. The "cut section", as it would appear, is drawn. The position of the cutting plane is indicated by a thin, long chain, line with thick extremities (Line Type F1, pg. 14). This chain line is labeled with capital letters with the direction of viewing indicated by arrows. The capital letters are placed behind the arrows in the direction of viewing. The lay out of sections and the designation/naming of sectional views is the same as for the corresponding ordinary external views.

General Hints

- Sometimes, only a small portion of the component is sectioned to indicate the feature of interest
- Parts (features) behind the sectioning plane are not shown, except when clarity requires this
- Hatch the solid part of the component that is "cut through" by the sectioning plane. Hatching lines are thin, parallel lines usually drawn at an angle of 45° to the outlines or the center lines of the object. The spacing of these lines depend on the size of the drawing
- Some standard parts/features are usually not sectioned (e.g. shafts, bolts, nuts, rivets, keys, pins, ridges, ribs, etc)
- For symmetrical components/features, only half of the component is sectioned along the line of symmetry
- Sections through two intersecting cutting planes are drawn as if these sections were in one plane

EXAMPLE:

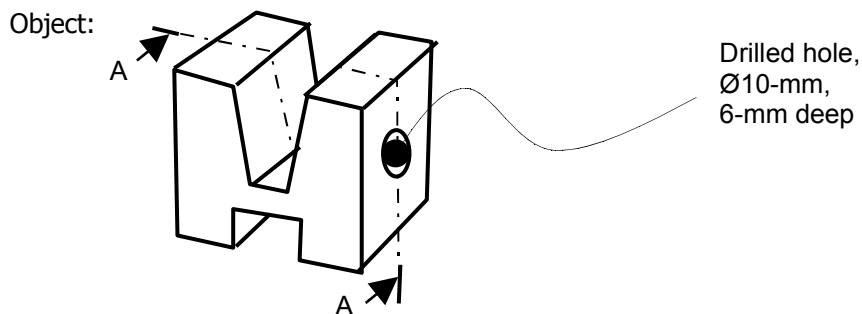

SOLUTION

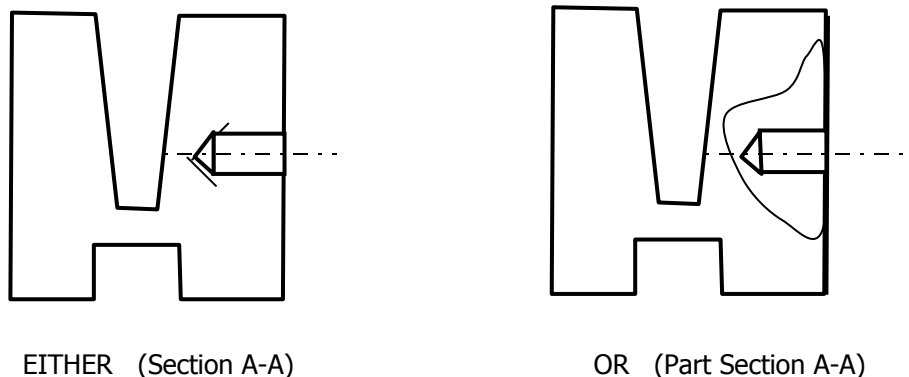

2.4.4 Dimensioning

To enable productions of machine parts/components, all the relevant dimensions have to appear on the drawing. The practice is that any dimension is shown only once in that view in which it appears more

explicitly. For this reason, it is not surprising that most of the important dimensions appear in the front view. Repetitions are discouraged unless clarity necessitates this. To keep the drawing clean, it is advised to put all the dimensions outside the drawing, except where and when this is unavoidable.

There are three types of dimensions; Functional Dimensions (FD), Non-Functional Dimensions (NFD) and Auxiliary Dimensions (AD)

Functional Dimensions (FDs)

These are dimensions, which directly dictate the functioning of the component. That is a FD is a dimension defined on the basis of the function of the product and the method of locating it in any assembly of which it may form part of, e.g. the diameter of a shaft, the length of a bolt, etc.

Non-Functional Dimensions (NFDs)

These are dimensions, which do not directly affect the functioning of the component but have to be specified to enable production of that component, e.g. the size of a bolt head.

Auxiliary Dimensions (ADs)

These are dimensions which should not necessarily appear on the drawing but are sometimes included to avoid calculations or when they would provide additional/useful information. ADs are usually written in brackets.

EXAMPLE: A bolt

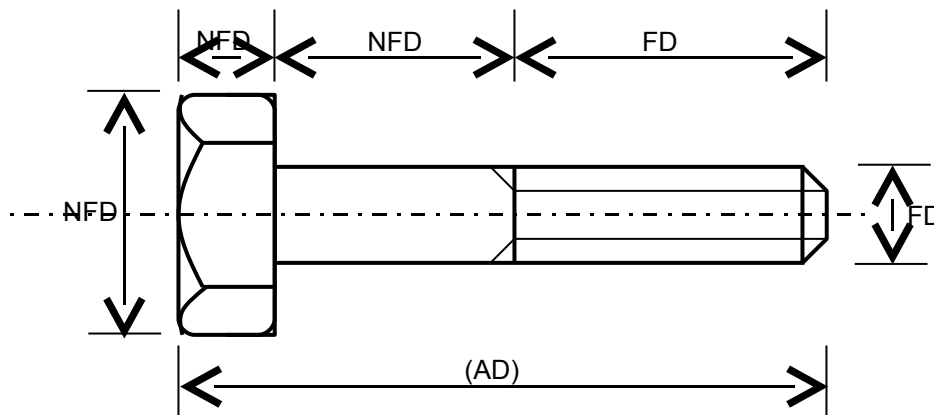

General Hints on Dimensioning

- NOTE that all "rules" on dimensioning are just guidelines. Use common sense depending on circumstances (i.e. there are no strict rules/regulations on dimensioning)
- In metric system, all linear dimensions are considered to be in millimeters
- Show full size dimensions regardless of the scale used in the drawing

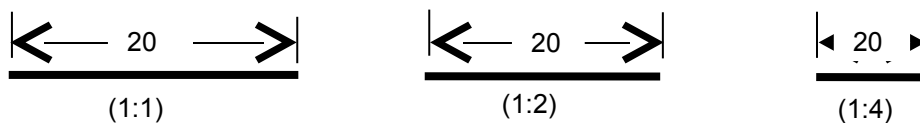

- Dimension in a manner that makes it unnecessary to calculate any required size information

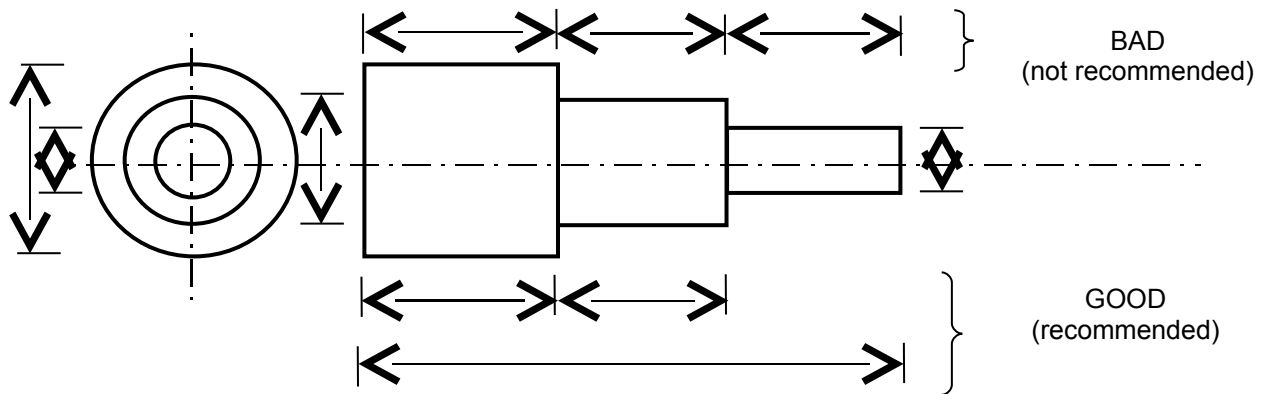

- For any feature, place the dimensions where the feature appears most explicitly

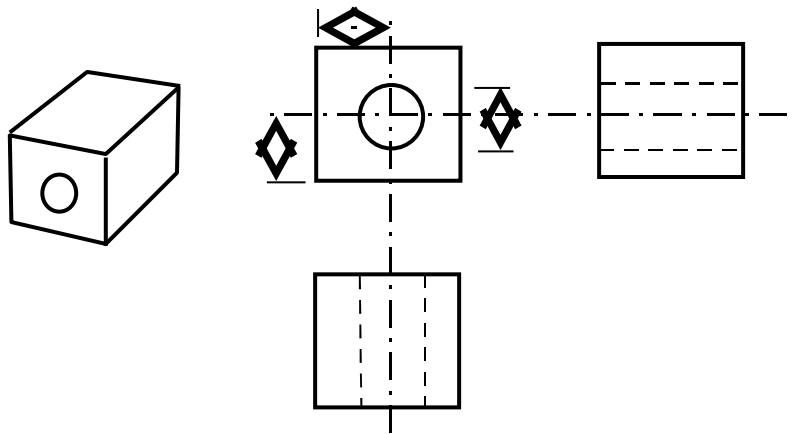

- Dimension any feature only once (i.e. no repetitions are allowed)
- Dimension obviously identical features only once

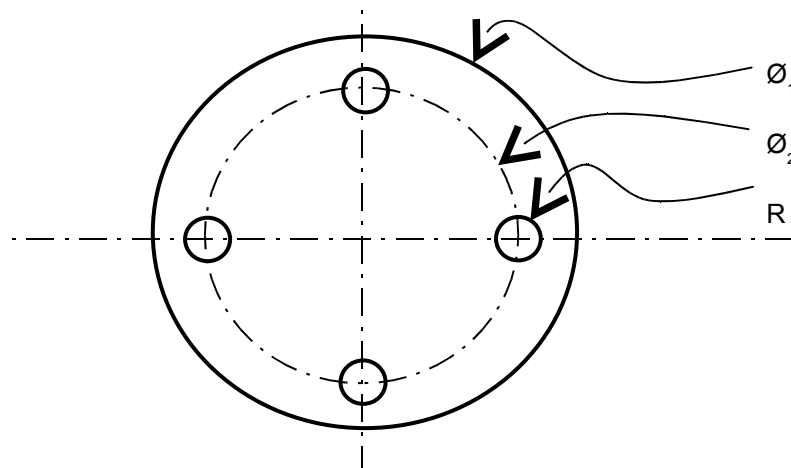

2.4.5 Some Special Features

Some features that we encounter are either too difficult to draw as they appear or they appear too often such that simplified symbols are commonly used in their place. They are may such features, but for our purpose we will consider just a few of them that are relatively more common. These will include; threaded parts, machined holes, chamfers, countersinks and specially treated surfaces.

Threaded Parts

Threads are machined according to different standards. However, the trend nowadays is to machine threads (and other standard features) according to ISO standards. A letter "M" followed by a number designates the size of the threads. The "M" stands for *metric* and the number that follows thereafter indicates the *diameter* (in mm) of the shaft upon which the threads have been machined. Male threads (e.g. on a bolt) and female threads (e.g. on a nut) of the same size are designated by the same M-number. This number actually specifies not only the size of the threaded part but also the size of the bolt head and the size of the nut (if all are made in accordance to the ISO standard). NOTE that by specifying the thread size (the M-number) automatically covers such details as; the nominal diameter, the pitch, the pitch diameter, the minor diameter, the major diameter, the various radii etc.

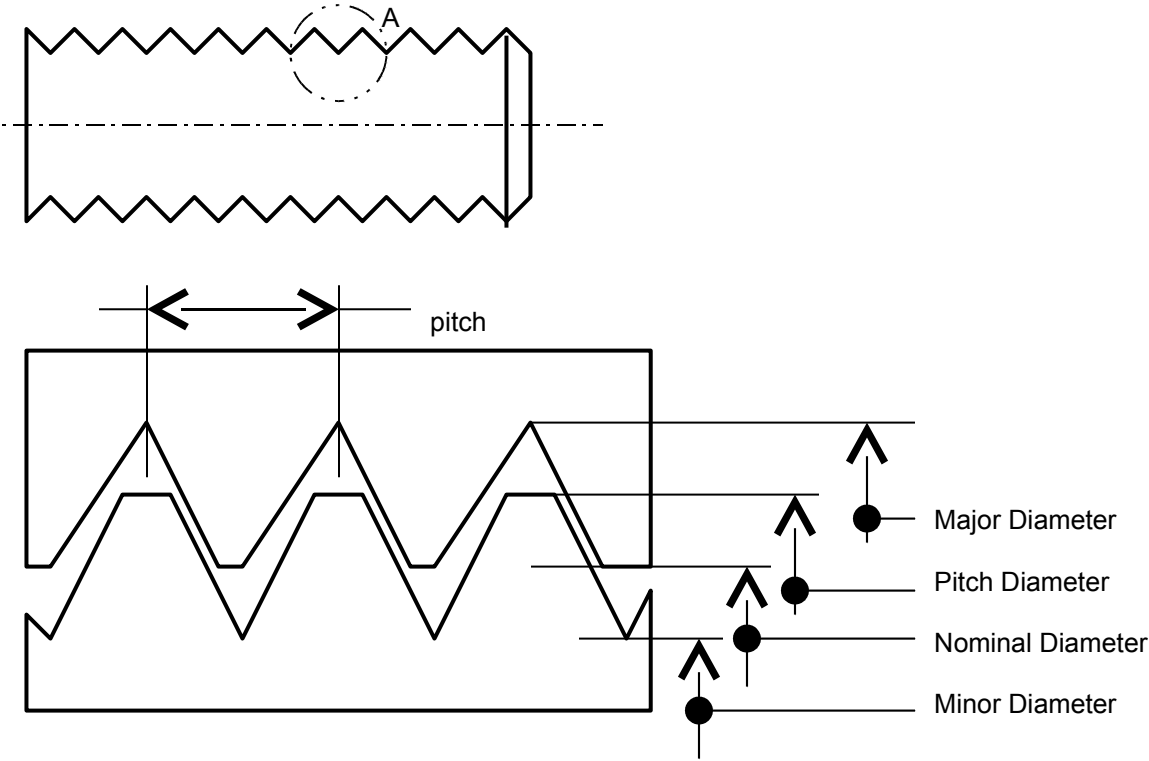

EXAMPLE: M10 – Male and Female threads

SOLUTION:

MALE THREADS

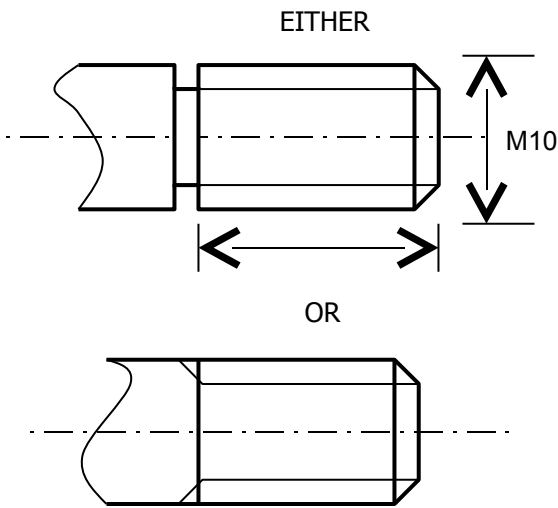

FEMALE THREADS

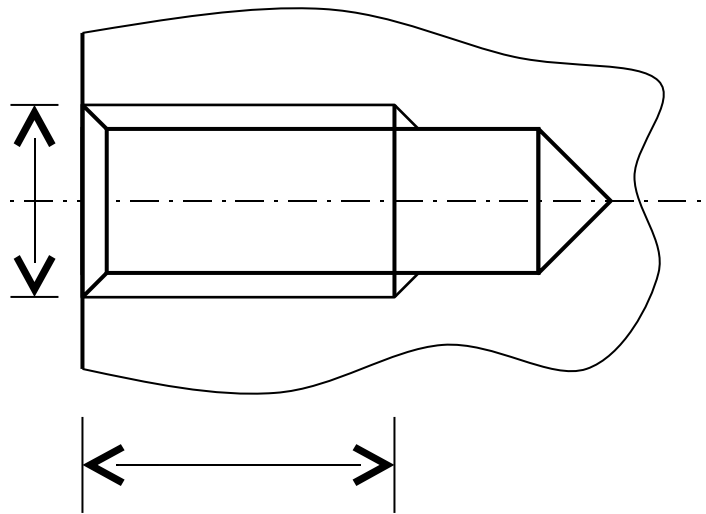

Machines Holes (Drilled and Milled holes)

Drilled Holes

Drilled holes are distinguished from holes machined by other methods by their characteristic tapered end. The shape of the drill bit brings about the tapered end.

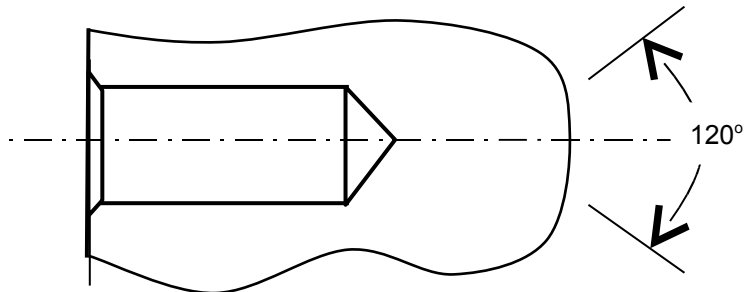

Milled Holes

Unlike drilled holes, milled holes have a flat end.

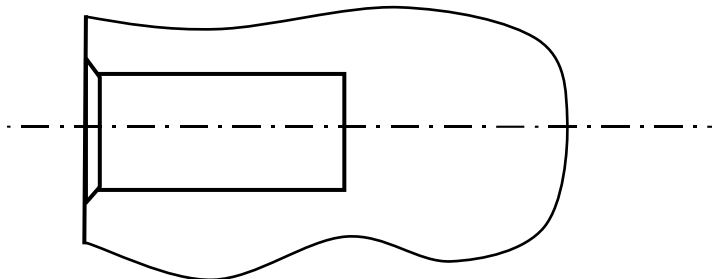

Chamfers and Countersinks

At the end of each shaft or any drilled/machined hole, a small tapered end is machined just to eliminate the sharp edge. This is important because

- The sharp edge may hurt people during handling and/or on assembling
- The sharp edge wears and tears fast

Chamfers

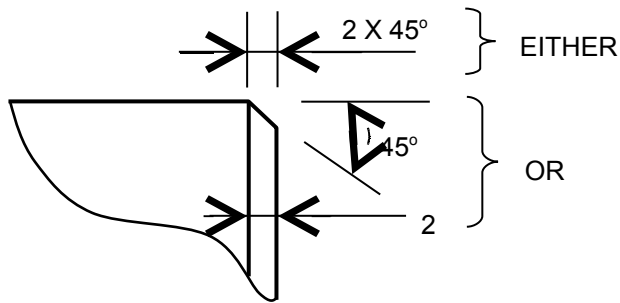

Countersink

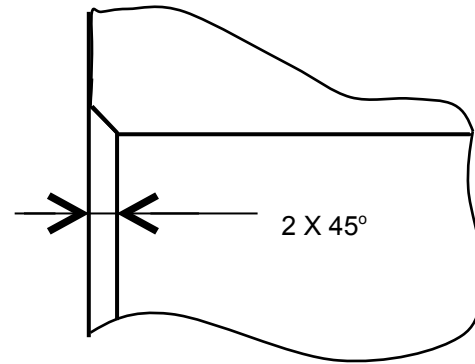

Specially Treated Surfaces

If the surface demands special treatments (e.g. to be covered by wear resistance material, special lacquer etc), this has to be shown on the drawing. This is indicated on the drawing as follows:

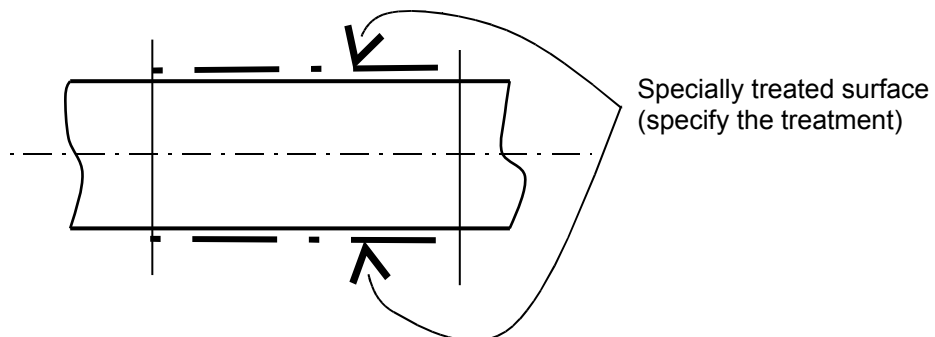

2.4.6 Tolerances and Fits

- Tolerance is simply defined as "*the degree (extent) of acceptable inaccuracy*"
- It describes *dimensional accuracy/inaccuracy*
- Tolerance is necessary under *mass production*
- *Absolute size* (nominal size) is only theoretical/hypothetical
- Tolerance specifies the acceptable upper and lower limits for a given nominal size
- Usually two extreme conditions are of interest: *tight fit* and *loose fit*

EXAMPLES

1: PIN and RING

You may need a tight fit or a loose fit between a pin and a ring – depending on circumstances

SOLUTION

(A) Tight Fit

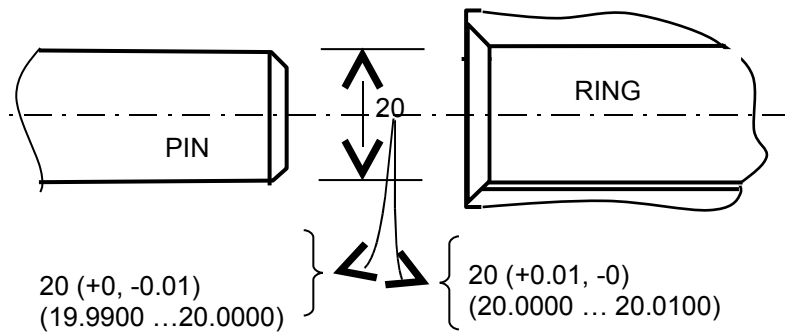
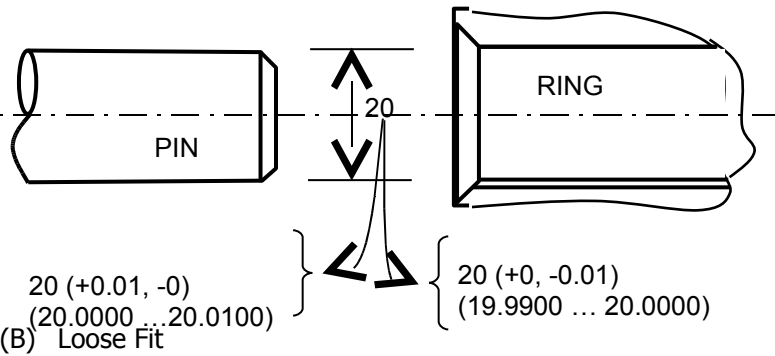

2: LOCOMOTIVE TYRE AND WHEEL

A very Tight Fit

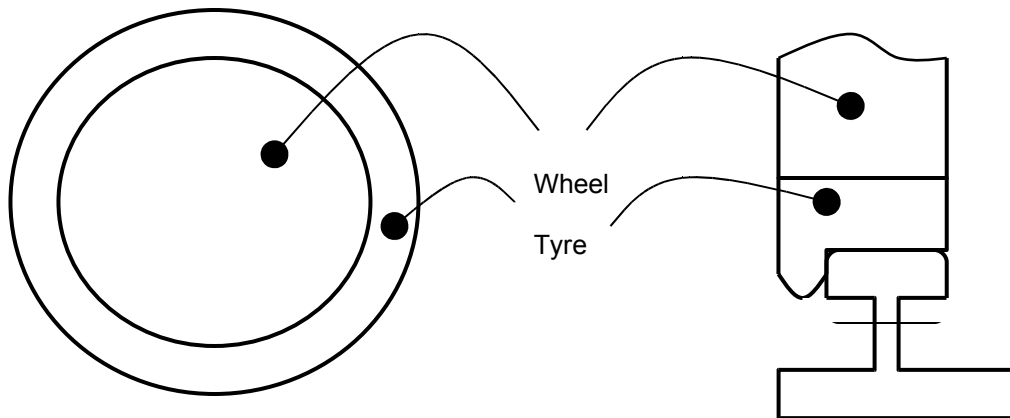

2.5 Assembly Drawings

As the name indicates, assembly drawings are nothing more but a collection of detail drawings (each of which forms part of that assembly) put together in a logical way. The drawing serves someone who is to assemble the individual parts so as to get a single unit in its working condition.

NOTES

- ◆ Only the external extreme dimensions of the assembly are indicated
- ◆ Each component is identified by its part reference number. This number is used in the parts list (where details of that part are indicated e.g. the drawing number for its detail drawing).

- ◆ Sectional views are in most cases preferred as they show in a detailed form how the parts interact in an assembly
- ◆ Only one view is normally drawn, unless where the unit is so complex such that the interaction of all parts can not be clearly presented in one view

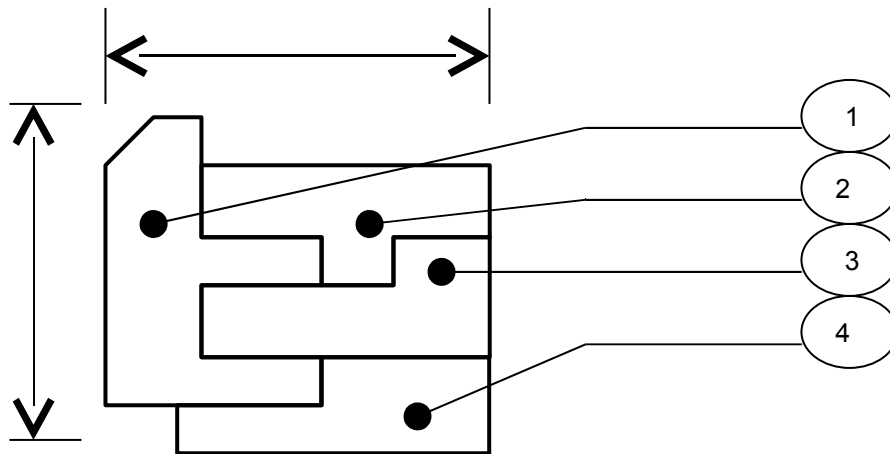

- ◆ If the unit has one or more moving parts, the extreme positions of the moving part are indicated in dotted lines (and the dimensions). This allows for consideration on space limitation during installation

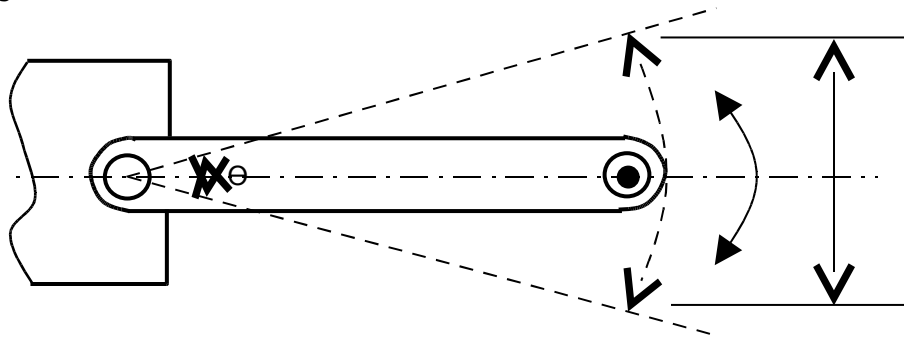

- ◆ Detail specifications of the individual parts are never shown on an assembly drawing (as they already appear on the respective detail drawing of the respective part)

EXAMPLE:

Draw an assembly of two stainless steel plates (SS 306) held together by a bolt and a nut (SS 318).

SOLUTION

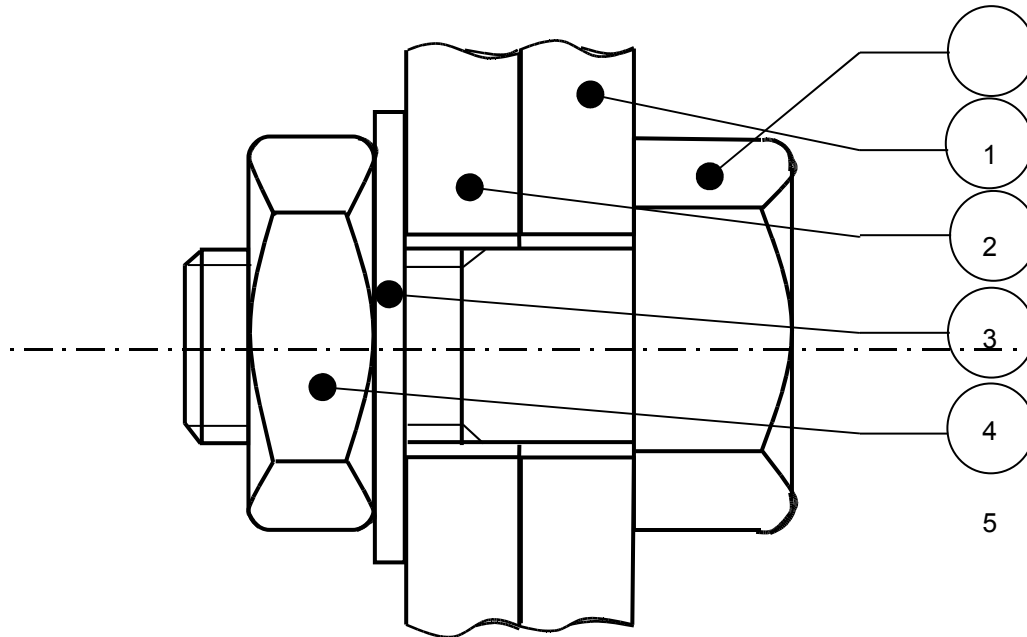

5	Nut	1	SS 318	M10	005
4	Washer	1	SS 318	M10	004
3	Plate # 2	1	SS 306	–	003
2	Plate # 1	1	SS 306	–	002
1	Bolt	1	SS 318	M10	001
REF. NUMBER	NAME OF PART	NO. REQ'D	MATERIAL	STANDARD/ DIMENSION	DRW. NUMBER

NOTE that materials SS 306 and SS 318 are different

Part – 3: EXERCISES

Exercises will be given in class as deemed appropriate.