

Comparative Analysis of Fuzzy Logic Controller and Conventional PID for Temperature Control

Ritu Shakya¹, Kritika Rajanwal², Sanskriti Patel³
hritu.iet@gmail.com, er.kritika@gmail.com, sanskritipatel01@gmail.com
^{1,2,3} Department of Electrical and Engineering
 Shri Ram Murti Smarak College of Engineering and Technology, Bareilly

ABSTRACT- Measuring of temperature control is a critical need in many industrial plants. The aim of this paper is to do the comparative study of fuzzy logic controller and conventional PID controller for temperature control. In this paper performance analysis of the conventional PID controller and fuzzy logic controller has been done by the use of MATLAB and simulink. From the result the fuzzy logic controller has small overshoot and fast response as compared to PID controller. Fuzzy control is based on fuzzy logic provides a means of converting a linguistic control strategy based on expert knowledge into an automatic control strategy

Keyword- fuzzy logic control, MATLAB/Simulink, PID controller, Mamdani fuzzy inference system.

I. Introduction

The temperature control is a key part of the machine. So this controlling process is achieved by designing the controller for the transfer function with the desired set point. Proportional integral derivative (PID) Controller are widely used in control application, but its performance is very poor when applied to system. The performance of PID controller is evaluated in terms of rise time and steady state error. The tuning of PID controller is difficult due to insufficient knowledge of the parameters of the system. Sometimes the PID control makes overshoot and also with regard to the temperature control system the characteristics of which are distributed parameters, non-linear, large time delay and large inertia, the conventional PID controller is very difficult to obtain satisfactory control results. To solve this problem, fuzzy logic technology is used. The temperature control system is playing an important role in industrial production. Recently, lots of researches have been investigated for the temperature control system based on various control strategies like ZN method but fuzzy is the advanced controlling method. The temperature control system based on fuzzy PID is proposed in this paper. The new algorithm based on fuzzy PID can improve the performance of the system. Also, it's fit for the complicated variable temperature control system. The simulation results show that the validity of the proposed strategy is more reliable and effective to control temperature.

II. Design consideration

A PID controller is being desired for a higher order system with transfer function

$$G(s) = 10 / [s(s^2 + 6s + 8)] \quad (1)$$

. We have proposed design of (i) PID controller (ii) fuzzy controller so that the closed loop system exhibit small overshoot M_p and settling time t_s with zero steady state error e_{ss} .

III. Design of PID Controller

A simple strategy which widely used for industrial control is PID controller. But the parameter selection for the K_p , K_i and K_d gain is always difficult. Many tuning algorithms are developed, but it is still difficult to select particular algorithm for designing PID gain values for the particular system for particular process control. Fig.2 shows the mathematical description of general PID controller.



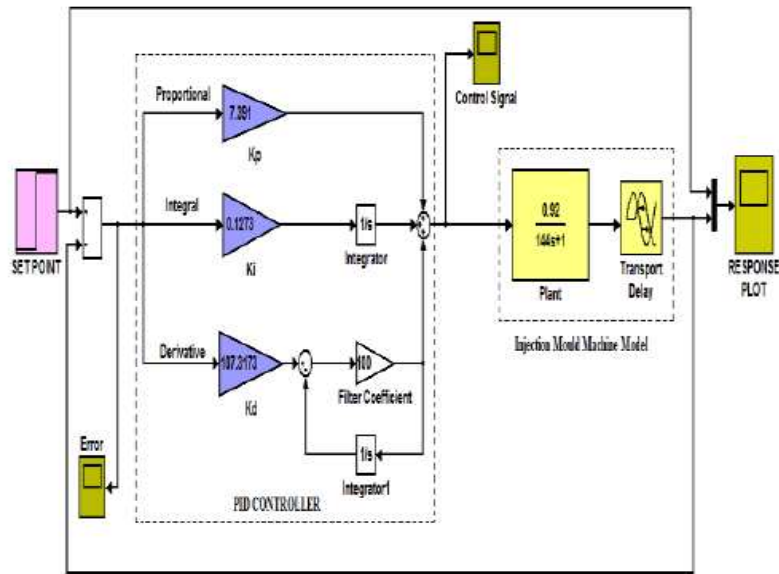

• Figure.2. system design with PID controller [22]

$U(t)$ = Control signal applied to plant

K_P = Proportional gain

K_I = Integral gain

K_D = Derivative gain.

The selection of these K_P , K_I and K_D values will cause for the variations in the observed response with respect to the desired response. In general, the dependency will be as per the Table.1.

Table I. Effect of increasing parameter values independently on the response

Parameter	Rise Time (T_r)	Overshoot (M_p)	Settling Time (T_s)	Error (E_{ss})
KP	Decrease	Increase	Small Change	Decrease
KI	Decrease	Increase	Increase	Decrease Significantly
KD	Minor Decrease	Decrease	Decrease	No effect

From the table, it is observed that PD controller gives the good steady state conditions, PI controller helps in reducing steady state error and PID controller is used to achieve all the advantages of individual control actions. Hence we use PID controller for temperature control in this paper.

IV. SYSTEM DESIGN WITH FLC

Simulink model of the fuzzy controller and the plant with unity feedback is shown in Figure.2

Comparative Analysis of Fuzzy Logic Controller and Conventional PID for Temperature Control

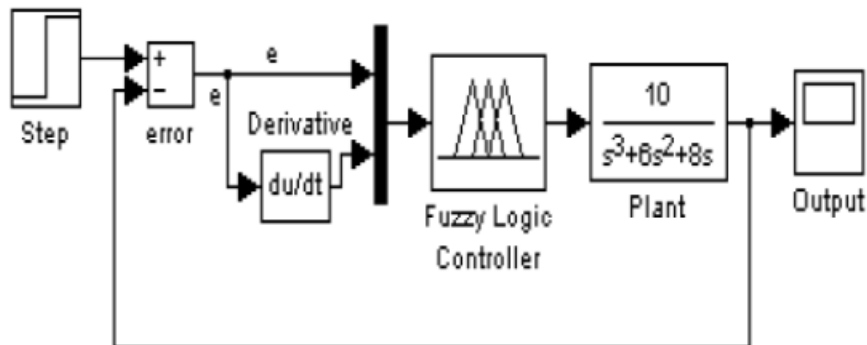

• Figure.3. System with FLC [23]

Fuzzy logic controller is easy to implement. Fuzzy logic is one of the most successful technologies in industrial control system because it is very simple.

Fuzzy logic refers to a logical system that generalizes classical two valued logic for reasoning under uncertainty. Fuzzy control system is a control system based on fuzzy logic. Fuzzy logic is a mathematical system that analyzes analog input values in terms of logical variables that take on values between 0 and 1 as shown in figure 3, in contrast to classical crisp or digital logic, which operates on discrete values of either 0 or 1 (OFF or ON). Defuzzification is the process of producing a quantifiable result in fuzzy logic, given fuzzy sets and corresponding membership degrees.

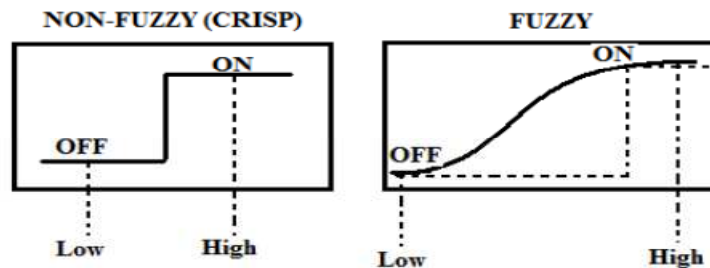

• Figure.4. Difference between crisp and fuzzy values [22]

Figure.4 shows the system architecture with fuzzy logic controller. Fuzzy logic controller has two inputs namely error and change in error and produces control signal according to the fuzzy inference structure (FIS) designed with fuzzy rules. Each of the input and output quantity is described with its corresponding membership function.

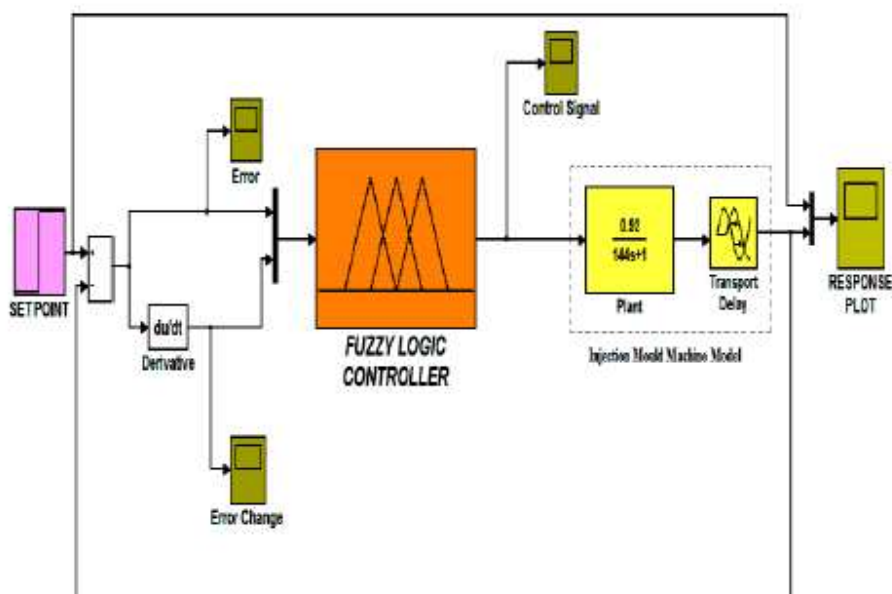

• Figure.5. System design with FLC [22]

There are three principle elements to a fuzzy logic controller

- A) Fuzzification module (fuzzifier)
- B) Rule base and inference engine
- C) Defuzzification module (Defuzzifier)

V. Principles of Fuzzy Modelling

The general algorithm for a fuzzy system designer can be synthesized as follows.

A) Fuzzification

- (1) Normalize of the universes of discourses for the fuzzy input and output vector.
- (2) Convert crisp data into fuzzy data or membership function.
- (3) Calculate the membership function for every crisp value of the fuzzy input.

B) Fuzzy Inference

- (4) Combine membership function with the rule to drive the fuzzy output.
- (5) Calculation of the membership function for every crisp value of the fuzzy input.

C) Defuzzification

- (6) Calculate the fuzzy output, using suitable defuzzification method.

A. FUZZY MEMBERSHIP FUNCTION

A membership function for a fuzzy set A on the universe of discourse X is defined as $\mu_A: X \rightarrow [0,1]$, where each element of X is mapped to a value between 0 and 1. This value, called membership value or degree of membership, quantifies the grade of membership of the element in X to the fuzzy set A.

B. TYPES OF INFERENCE SYSTEM



Comparative Analysis of Fuzzy Logic Controller and Conventional PID for Temperature Control

Mamdani-Type Fuzzy Inference- is defined for the toolbox, expects the output membership functions to be fuzzy sets. After the aggregation process, there is a fuzzy set for each output variable that needs defuzzification.

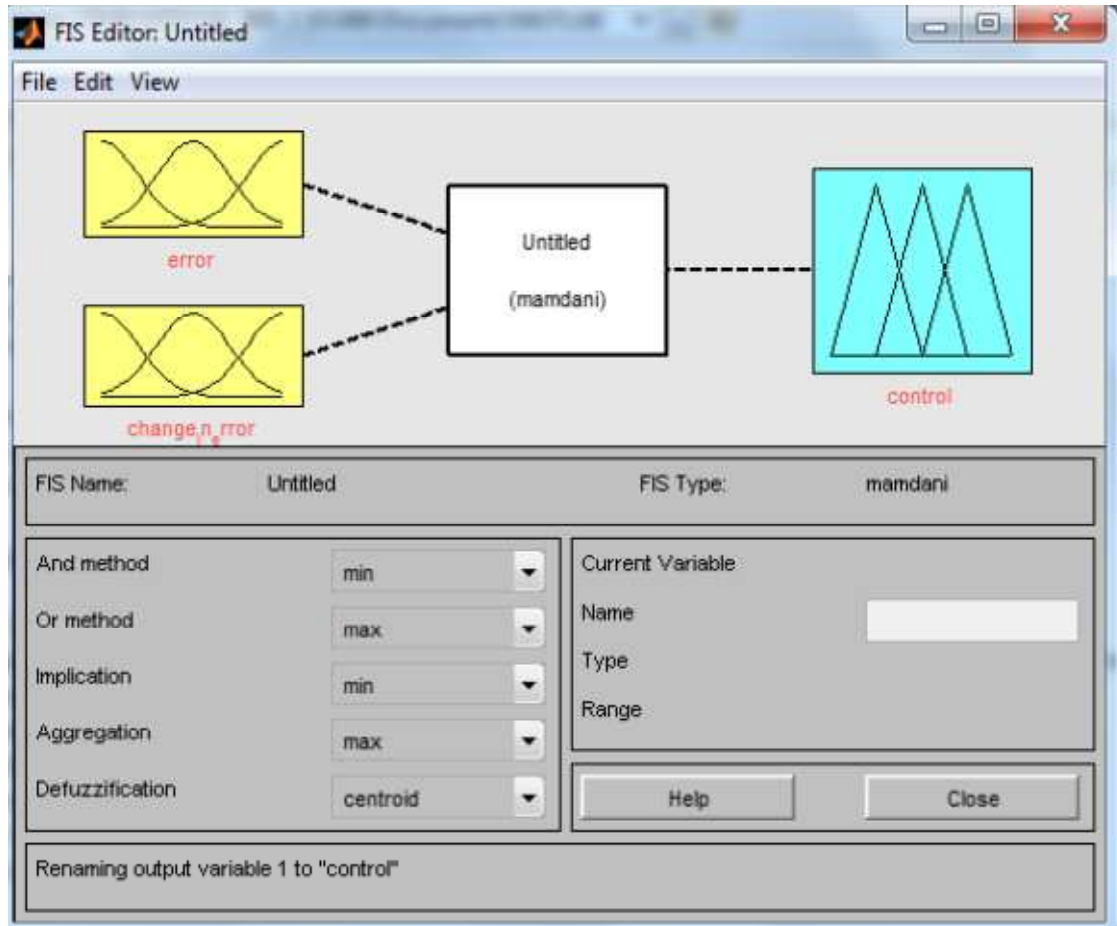

• Figure.6. Selection of number of I/O for designing FIS for FLC

Sugeno-Type Fuzzy Inference- This topic discusses the so-called Sugeno, or Takagi-Sugeno-Kang, method of fuzzy inference. Introduced in 1985, it is similar to the Mamdani method in many respects. The first two parts of the fuzzy inference process, fuzzifying the inputs and applying the fuzzy operator, are exactly the same. The main difference between Mamdani and Sugeno is that the Sugeno output membership functions are either linear or constant.

C. FUZZY RULES FOR DEVELOPING FIS

Fuzzy inference is the process of formulating the mapping from a given input to an output using fuzzy logic. The mapping then provides a basis from which decisions can be made, or patterns discerned. The process of fuzzy inference involves all of the pieces that are described in the previous sections: Membership Functions, Logical Operations, and If-Then Rules.

VI. SIMULATION RESULTS

The figure 6 and 7 shows the response of conventional PID controller and the response of the fuzzy logic controller to the step input.

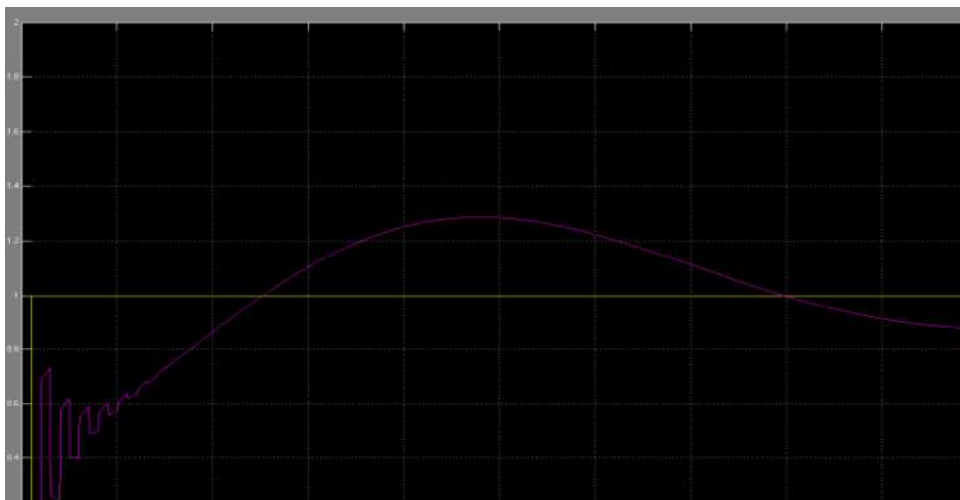

• Figure.7. The step response of the conventional PID controller

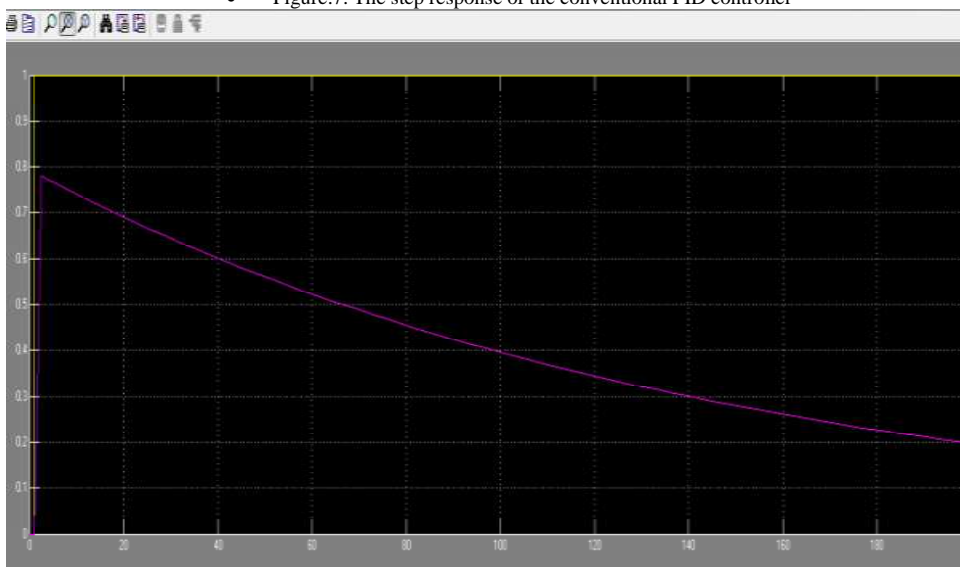

• Figure.7. The step response of the fuzzy logic controller

VII. Conclusion

The response of the PID controller is oscillatory which can damage the system. But the response of the fuzzy logic controller is free from these dangerous oscillations in the transient period. Hence the proposed FLC is better than the conventionally used PID controller.

Comparative Analysis of Fuzzy Logic Controller and Conventional PID for Temperature Control

REFERENCES

- [1] Gang Feng, "Analysis and Synthesis of Fuzzy Control Systems: A Model Based Approach, Automation and Control Engineering Series," CRC Press, Taylor and Francis, 2010.
- [2] P. Melba Mary and N.S. Marimuthu, "Design of self-tuning fuzzy logic controller for the control of an unknown industrial process," IET Control Theory Appl., 2009, Vol. 3, Iss. 4, pp. 428–436.
- [3] Shi Xinmin and Hao Zhengqing, "Fuzzy Control and Its MATLAB Simulation," Tsinghua University Press, Beijing Jiaotong University Press, Beijing, 2008, pp. 89-126.
- [4] Zhang Huaguang and He Xiqin, "Theory and Application of Fuzzy Adaptive Control[M]," Beihang University Press, Beijing, 2002, pp.297-303.
- [5] Tao Yonghua, Yin Yixin, and Ge Lusheng, "New Type of PID Control and Its Application[M]," 2000, pp.101-142.
- [6] Su Ming, "Fuzzy PID control and Its MATLAB Simulation" [J]. Journal of Computer Applications, 2004. (4), pp. 51-55.
- [7] Yi Jikai and Hou Yuanbin, "Intelligent Control Technology [M]," Beijing Technology University Press, Beijing, 1999:192-214.
- [8] Liu Jinkun, "MATLAB Simulation of Advanced PID Control[M]," Electronic Industry Press, Beijing, 2006, pp. 102-129.
- [9] Hongbo Xin, Tinglei Huang, Xiaoyu Liu, and Xiangjiao Tang, "Temperature Control System Based on Fuzzy Self-Adaptive PID Controller," In the proc. of Third International Conference on Genetic and Evolutionary Computing, 2009, pp. 537-540.
- [10] Hongfu Zhou, "Simulation on Temperature Fuzzy Control in Injection Mould Machine by Simulink," Guangdong Provincial Science and Technology Founding of China, 2007.
- [11] C.F. Juang, "An automatic building approach to special Takagi-Sugeno fuzzy network for unknown plant modeling and stable control," Asian J. Control 5 (2003) (2), pp. 176-186.
- [12] C.F. Juang and C.T. Lin, "An on-line self-constructing neural fuzzy inference network and its applications," IEEE Transactions on Fuzzy Systems 6 (1998), pp. 12-32.
- [13] C.F. Juang and C.T. Lin, "A recurrent self-organizing neural fuzzy inference network," IEEE Trans. Neural Networks 10 (1999), pp. 828-845.
- [14] King P J, et. "The Application of Fuzzy Control System to Industrial Processes," in IFAC world Congress. MIT.Boston, 1975.
- [15] Tanaka K and Ugeno, "Stability Analysis and Design of Fuzzy Controller," Fuzzy sets and systems, 1992.
- [16] Xiaodong Zhao, Zhuzhen wang, and Haiyan Wang, "Design of series leading correction PID controller," In the proc. of IEEE International Conference, 2009.
- [17] Shehu S and George Vachtsevanos, "Robust Stability of FuzzyLogic Control Systems," America Control Conference, 1995.
- [18] Curtis D Johnson, "Process Control Instrumentation Technology," Pearson Education, 2009.
- [19] John Yen and Reza Langari, "Fuzzy Logic-Intelligence, Control, and Information," Pearson Education, 2007.
- [20] A Nagoor kani, "Control Systems," First edition, RBA Publications, 2002.
- [21] Sahil Chandan, Rahul Agnihotri, "Fuzzy logic Controller for Flowing Fluids", Volume 1, Issue 4, June 2012.
- [22] Dr. I Santi Prabha, K Durga Rao, D Siva Rama Krishna, "Fuzzy Logic Based Intelligent Controller Design for an Injection Mould Machine Process Control", Vol No. 10, Issue No. 1, 098 – 103.
- [23] S.R.Vaishnav, Z.J.Khan, "Design and Performance of PID and Fuzzy Logic Controller with Smaller Rule Set for Higher Order System", WCECS 2007, October 24-26, 2007, San Francisco, USA