

Unit 41: Fluid Mechanics

Unit code: T/601/1445

QCF Level: 4

Credit value: 15

PR-REQUISITE TUTORIAL **MOMENTS OF AREA**

The contents of this tutorial are essential for successful completion of the unit but it may be skipped if you are already familiar with the topic.

In this section you will do the following.

- Define the centre of area.
- Define and calculate 1st. moments of areas.
- Define and calculate 2nd moments of areas.
- Derive standard formulae.

1. CENTROIDS AND FIRST MOMENTS OF AREA

A moment about a given axis is something multiplied by the distance from that axis measured at 90° to the axis.

The moment of force is hence force times distance from an axis.

The moment of mass is mass times distance from an axis.

The moment of area is area times the distance from an axis.

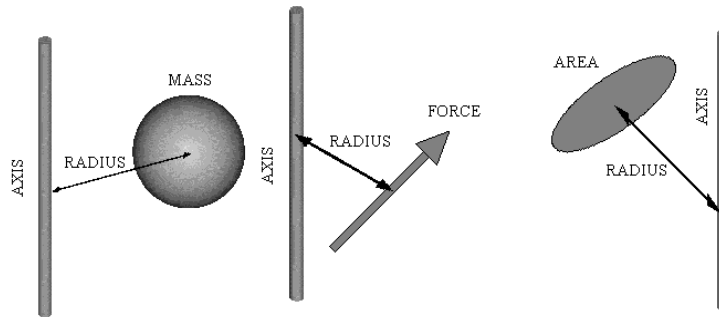

Fig.1

In the case of mass and area, the problem is deciding the distance since the mass and area are not concentrated at one point.

The point at which we may assume the mass concentrated is called the centre of gravity.

The point at which we assume the area concentrated is called the centroid.

Think of area as a flat thin sheet and the centroid is then at the same place as the centre of gravity. You may think of this point as one where you could balance the thin sheet on a sharp point and it would not tip off in any direction.

This section is mainly concerned with moments of area so we will start by considering a flat area at some distance from an axis as shown in Fig.1.2

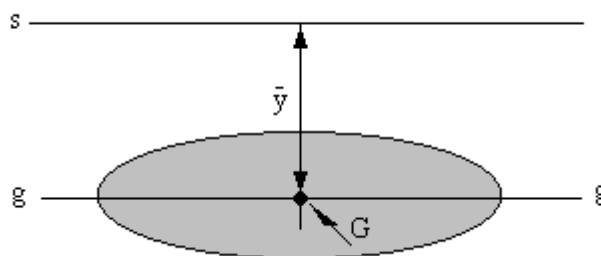

Fig..2

The centroid is denoted G and its distance from the axis s-s is y. The axis drawn through G parallel to s-s is the axis g-g. The first moment of area about the axis s-s is the product of area A and distance.

$$\text{1st moment of area} = A \bar{y}$$

From this we may define the distance y.

$$\bar{y} = \text{1st moment of area} / \text{Area.}$$

For simple symmetrical shapes, the position of the centroid is obvious.

WORKED EXAMPLE 1

Find the formula for the first moment of area for rectangle about its longer edge given the dimensions are B and D.

SOLUTION

The centroid is at the middle of the rectangle and may be found at the point where the two diagonals cross. In other words it is half way from either edge. The distance from the long edge is hence $D/2$.

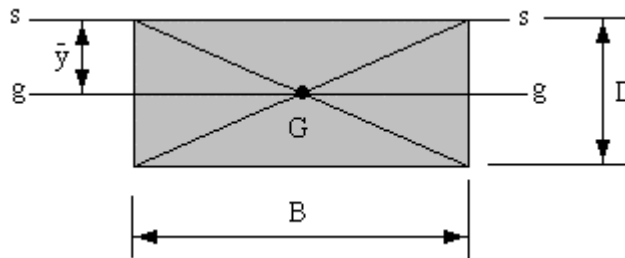

Figure 1.3

$$y = D/2$$

$$A = BD$$

$$\text{1st moment} = A \bar{y} = BD^2/2$$

WORKED EXAMPLE 2

Find the formula for the 1st moment of area of a circular area about an axis touching its edge in terms of its diameter d.

SOLUTION

The centroid is at the geometric centre distance one half diameter from the edge.

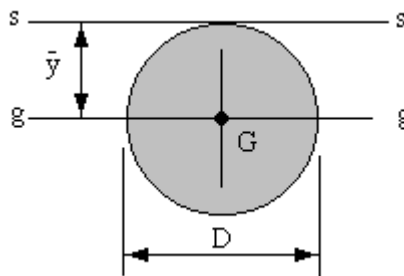

Fig.4

$$\bar{y} = D/2$$

$$A = \pi D^2/4 \quad \text{1st moment} = A \bar{y} = (\pi D^2/4)/(D/2) = \pi D^3/8$$

COMPLEX AREAS

In order to find the moment of area of more complex shapes we divide them up into sections, solve each section separately and then add them together.

WORKED EXAMPLE 3

Calculate the 1st. moment of area for the shape shown about the axis s-s and find the position of the centroid.

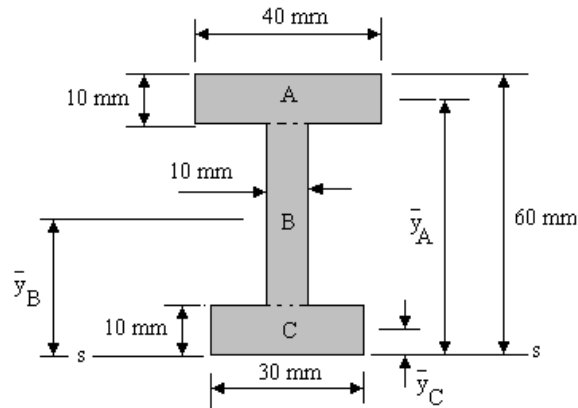

Fig.5

SOLUTION

The shape is not symmetrical so the centroid is not half way between the top and bottom edges. First determine the distance from the axis s-s to the centre of each part A, B and C. A systematic tabular method is recommended.

Part	Area	\bar{y}	Ay
A	400	55	22000
B	400	30	12000
C	300	5	1500
Total	1100		35500

The total first moment of area is 35 500 mm³.

This must also be given by $A \bar{y}$ for the whole section hence

$$\bar{y} = 35\,500 / 1100 = 32.27 \text{ mm.}$$

The centroid is 32.77 mm from the bottom edge.

SELF ASSESSMENT EXERCISE 1

1. Find the distance of the centroid from the axis $s - s$. All dimensions are in metres. (0.549 m).

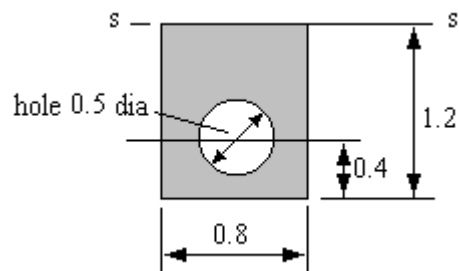

fig.6

2. Find the distance of the centroid from the bottom edge. All dimensions are in metres. (0.625 m)

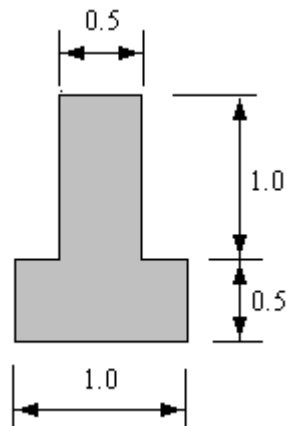

Fig.7

2. SECOND MOMENTS OF AREAS

2.2 GENERAL THEORY

If any quantity is multiplied by the distance from the axis s-s twice, we have a second moment. Mass multiplied by a distance twice is called the moment of inertia but is really the second moment of mass. We are concerned here with area only and the area multiplied by a distance twice is the second moment of area. The symbol for both is confusingly a letter I.

The above statement is over simplified. Unfortunately, both the mass and area are spread around and neither exists at a point. We cannot use the position of the centroid to calculate the 2nd. moment of area. Squaring the distance has a greater effect on parts further from the axis than those nearer to it. The distance that gives the correct answer is called the **RADIUS OF GYRATION** and is denoted with a letter k. This is not the same as \bar{y} .

The simplest definition of the 2nd. moment of area is $I = A k^2$

Whilst standard formulae exist for calculating the radius of gyration of various simple shapes, we should examine the derivations from first principles. We do this by considering the area to be made up of lots of elementary strips of width b and height dy. The distance from the axis s-s to the strip is y.

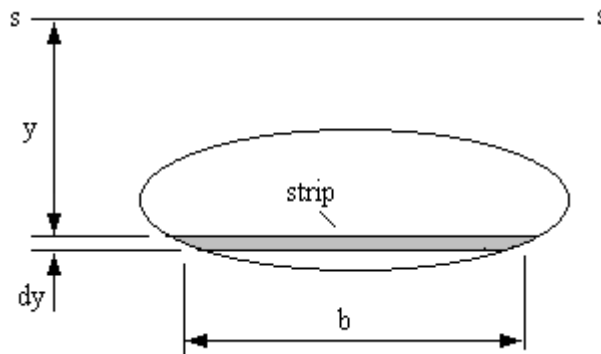

Fig.8

The area of the strip = $dA = b \, dy$

1st moment of area of strip = $y \, dA = b y \, dy$

2nd moment of area of strip = $y^2 \, dA = b y^2 \, dy$

For the whole area, the 2nd moment of area is the sum of all the strips that make up the total area. This is found by integration.

$$I = \int b y^2 \, dy$$

The limits of integration are from the bottom to the top of the area. This definition is important because in future work, whenever this expression is found, we may identify it as I and use standard formulae when it is required to evaluate it. We should now look at these.

WORKED EXAMPLE 4

Derive the standard formula for the second moment of area and radius of gyration for a rectangle of width B and depth D about an axis on its long edge.

SOLUTION

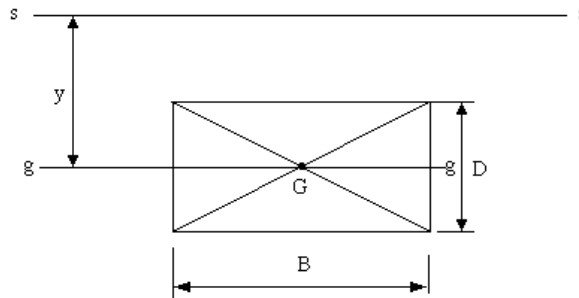

Fig.9

$$b = \text{constant} = B$$

$$I = \int_0^{\frac{D}{2}} by^2 dy = B \int_0^{\frac{D}{2}} y^2 dy$$

$$I = B \left[\frac{y^3}{3} \right]_0^{\frac{D}{2}} = \frac{BD^3}{12}$$

$$I = Ak^2 \quad k = \sqrt{\frac{I}{A}} = \sqrt{\frac{BD^3}{3BD}} = 0.577D$$

Note \bar{y} is 0.5 D and is not the same as k.

WORKED EXAMPLE 5

Derive the standard formula for the second moment of area and radius of gyration for a rectangle of width B and depth D about an axis through its centroid and parallel to the long edge.

SOLUTION

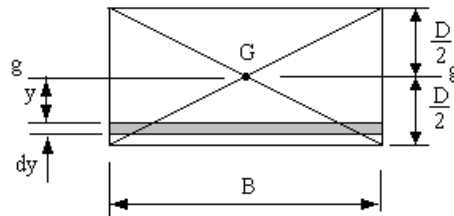

Fig.1.10

$b = \text{constant} = B$

$$I = \int_{-\frac{D}{2}}^{\frac{D}{2}} by^2 dy = B \int_{-\frac{D}{2}}^{\frac{D}{2}} y^2 dy$$

$$I = B \left[\frac{y^3}{3} \right]_{-\frac{D}{2}}^{\frac{D}{2}} = \frac{BD^3}{12}$$

$$I = Ak^2 \quad k = \sqrt{\frac{I}{A}} = \sqrt{\frac{BD^3}{12BD}} = 0.289D$$

Note \bar{y} is zero and not the same as k.

CIRCLES

The integration involved for a circle is complicated because the width of the strip b varies with distance y .

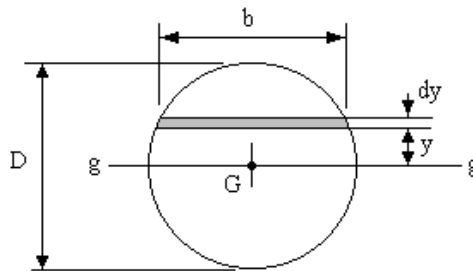

Fig.11

The solution yields the following result.

$$I = \frac{\pi D^4}{64} \quad k = \frac{D}{4}$$

2.2 PARALLEL AXIS THEOREM

If we wish to know the 2nd moment of area of a shape about an axis parallel to the one through the centroid ($g-g$), then the parallel axis theorem is useful.

The parallel axis theorem states $I_{ss} = I_{gg} + A (\bar{y})^2$

Consider a rectangle B by D and an axis $s-s$ parallel to axis $g-g$.

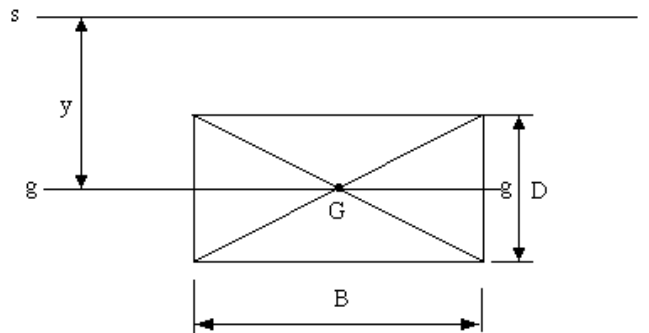

Fig.12

$$I_{gg} = \frac{BD^3}{12} \quad A = BD \quad I_{ss} = \frac{BD^3}{12} + BD\bar{y}^2$$

Consider when $s-s$ is the top edge.

$$I_{ss} = \frac{BD^3}{12} + BD\bar{y}^2 \quad \text{but } \bar{y} = \frac{D}{2} \quad \text{so } I_{ss} = \frac{BD^3}{12} + BD\left(\frac{D}{2}\right)^2 = \frac{BD^3}{12}$$

This is the result obtained previously and confirms the method.

WORKED EXAMPLE 6

Calculate the 2nd moment of area for the same shape as in worked example 1.3. about the axis s-s

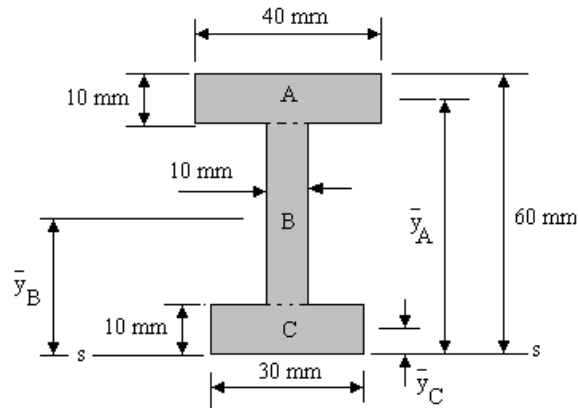

Fig.13

SOLUTION

The table shows the previous solution with extra columns added to calculate the second moment of area using the parallel axis theorem. In the new column calculate the second moment of area for each part (A, B and C) about each's own centroid using $BD^3/12$. In the next column calculate $A\bar{y}^2$.

Part	Area	\bar{y}	$A\bar{y}$	$I_{gg}=BD^3/12$	$A\bar{y}^2$	I_{ss}
A	400	55	22000	3333	1210000	1213333
B	400	30	12000	53333	360000	413333
C	300	5	1500	22500	7500	30000
Total	1100		35500			1656666

The total 2nd moment of area is 1656666 mm^4 about the bottom. We require the answer about the centroid so we now use the parallel axis theorem to find the 2nd moment about the centroid of the whole section.

The centroid is 32.77 mm from the bottom edge.

$$I_{gg} = I_{ss} - A\bar{y}^2$$

$$I_{gg} = 1656666 - 1100 \times 32.77^2$$

$$I_{gg} = 475405.8 \text{ mm}^4 = 475.4 \times 10^{-9} \text{ m}^4$$

$$\text{Note } 1 \text{ m}^4 = 10^{12} \text{ mm}^4$$

WORKED EXAMPLE 7

Calculate the second moment of area of the shape shown about the axis s – s.

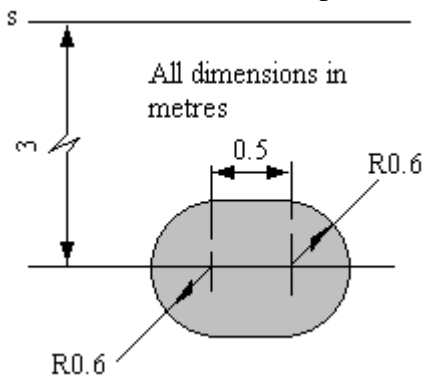

Fig.14

SOLUTION

The shape is equivalent to a circle 1.2 m diameter and a rectangle 0.5 by 1.2. All have their centroids located 3 m from the axis s – s.

$$I_{gg} = \frac{\pi d^4}{64} + \frac{BD^3}{12} = \frac{\pi \times 1.2^4}{64} + \frac{0.5 \times 1.2^3}{12} = 0.1018 + 0.072 = 0.1738 \text{ m}^4$$

$$\text{Area} = A = \frac{\pi d^2}{4} + BD = \frac{\pi \times 1.2^2}{4} + 0.5 \times 1.2 = 1.131 + 0.6 = 1.731 \text{ m}^2$$

$$\bar{y} = 3 \text{ m}$$

$$I_{ss} = I_{gg} + A\bar{y}^2 = 0.1738 + 1.731 \times 3^2 = 15.75 \text{ m}^4$$

SELF ASSESSMENT EXERCISE 2

1. Find the second moment of area of a rectangle 3 m wide by 2 m deep about an axis parallel to the longer edge and 5 m from it. (218 m^4).
2. Find the second moment of area of a rectangle 5 m wide by 2m deep about an axis parallel to the longer edge and 3 m from it. (163.33 m^4).
3. Find the second moment of area of a circle 2 m diameter about an axis 5 m from the centre. (79.3 m^4).
4. Find the second moment of area of a circle 5 m diameter about an axis 4.5 m from the centre. (428.29 m^4).
5. Find the 2nd moment of area for the shape shown the about the axis s – s. All the dimensions are in metres. ($35.92 \times 10^{-3} \text{ m}^4$)

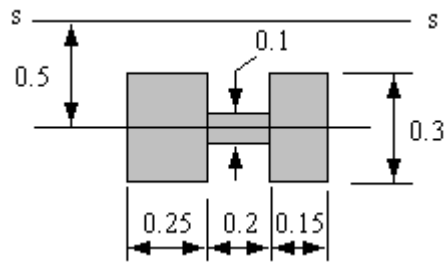

Fig.15

6. Find the 2nd moment of area for the shape shown the about the axis s – s. All the dimensions are in metres.. ($79.33 \times 10^{-3} \text{ m}^4$)

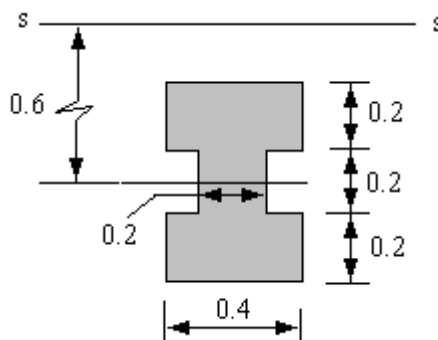

Fig.16

7. Find the position of the centroid for the shape shown and the 2nd moment of area about the bottom edge. (28.33 mm from the bottom and $2.138 \times 10^{-6} \text{ m}^4$)

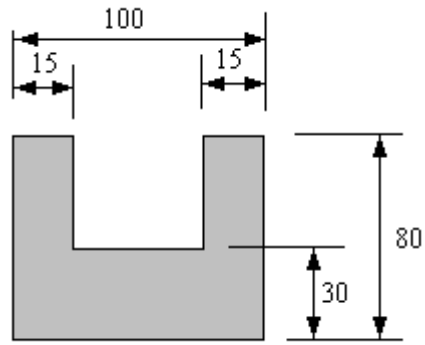

Fig.17