

# Multi-Agent Secure Dynamic Carpooling

Deepak B. Nagare, Kishor L. More, Nitin S. Tanwar, S.S.Kulkarni

**Abstract**— *Carpooling (also known as car-sharing, ride-sharing and lift sharing), is the sharing of car journeys so that more than one person travels in a single car [5]. Carpooling consists of sharing one’s personal vehicles with one or several passengers in which the related passengers shares the related costs but also help to reduce the traffic as well as pollution. One major issue in carpooling is the prior agreement between the car owner and the ride seekers. Dynamic carpooling uses an IT system to remove this limitation and provide ways to react to events such as a traffic jam as well as improving the quality of life benefits of participating people. But it requires accessing potentially sensitive information such as the real time users’ position or their identity. So there must be an efficient security mechanism should be implemented to protect data exchanged to provide the service but also to increase the users’ confidence in the tool. This paper mostly focuses on the security services allowing both the mutual authentication of the users and of the application components with the system.*

*Traffic congestion and the associated pressure in car parking, that results from increased number of cars on the road ,it require the study of innovative measures to reduce the number of cars traveling every day to the main areas in the city, specifically single occupant vehicles.*

**Keywords**—*CarOwner, Ride Seeker, Mobile Authentication, Multi-Agent System, Dynamic Carpooling.*

## I. INTRODUCTION

Ride-sharing on the daily home-work-home commute can help individuals save on gasoline and other car-related costs, while at the same time reducing traffic and pollution in the city [2]. In the European Union, over 60% of the population lives in urban areas (information from Euro stat). Air and noise pollution is getting worse each year. Urban traffic is responsible for 40% of CO2 emissions and 70% of emissions of other pollutants arising from road transport [5].

**Manuscript received on March, 2013.**

**Shriram S. Kulkarni**, Assistant Professor, Department of Information Technology, S.T.E.S.’s Sinhgad Academy of Engineering, Pune, University of Pune, India.

**Deepak B. Nagare**, B.E. Student, Department of Information Technology, S.T.E.S.’s Sinhgad Academy of Engineering, Pune, University of Pune, India.

**Kishor L. More**, B.E. Student, Department of Information Technology, S.T.E.S.’s Sinhgad Academy of Engineering, Pune, University of Pune, India.

**Nitin Singh Tanwar**, B.E. Student, Department of Information Technology, S.T.E.S.’s Sinhgad Academy of Engineering, Pune, University of Pune, India.

**Kalyan C. Gunda**, STSM, GPFS & SONAS Development IBM STG, Bangalore, India.

Carpooling consists of sharing one’s personal vehicles with one or several passengers in which the related passengers shares the related costs but also help to reduce the traffic as well as pollution. One major issue in carpooling is the prior agreement between the car owner and the ride seekers. Dynamic carpooling uses an IT system to remove this limitation and provide ways to react to events such as a traffic jam as well as improving the quality of life benefits of participating people. But it requires accessing potentially sensitive information such as the real time users’ position or their identity. So there must be an efficient security mechanism should be implemented to protect data exchanged to provide the service but also to increase the users’ confidence in the tool.

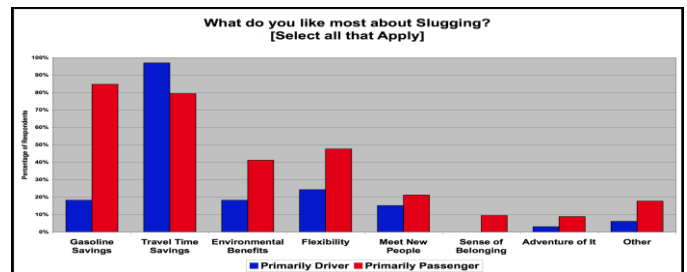

Fig. 1 Different Carpooling Benefits

This paper mostly focuses on the Security services allowing both the mutual authentication of the users and of the application components with the system [1].

Table 1 - Dynamic Carpooling Issues

Service	Description
Dynamic Carpooling	Provides real time planning for carpooler, carpooling with driver – passenger automated matching and allocation.
Location Tracing	Generate events when the user is not at the planned position.
Route Planning	Provides an optimized route to the Destination
Traffic Information	Traffic information provided by several third Parties.
Authorization & Accounting	Security pluggable components to identify and authorize services and users.
Mutual Authentication	Allow only authenticated users to access the application.

## II. SYSTEM CONCEPTS AND MAIN MODULES

The dynamic carpooling service relies on several secondary services to provide a quick reaction to change in the context and unforeseen events. These services are,

### A. Flexible Planning

In dynamic carpooling the ride seeker can be able to take ride anytime. He can take a new ride, cancel ride or modify it. Similarly when car owner send the leaving from home notation then all the respected ride seekers belonging to that road must get that notification. The car owner is not able to change the route once after acceptance of ride seekers requests because it may disturb the schedule of other ride seekers as it is real time system.

### B. Location tracing Services

After registering for any particular car the seeker may want to know that where the car is? So to solve this problem we can take help of Google map. It has some inbuilt functionalities which display the location of car to user so that he will come to know that where the car is and for how much time he has to wait.

### C. Mobile Application

It is possible to use smart phones supporting android applications to use this application. It is very easy to access the application from smart phones having internet connectivity. For every event all the participants receive notifications.

### D. MultiAgent Service Architecture

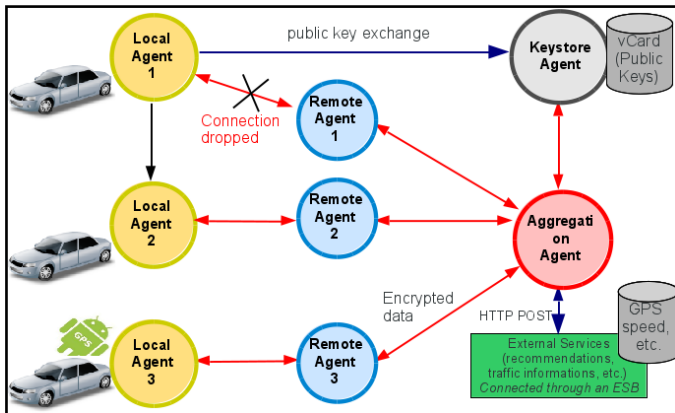

Fig. 2 Multi-Agent Architecture

Each agent has responsibilities and capabilities in order to achieve a specific task. Local agents are running on the user's devices and are the bridge between the Android application and the dedicated server. Local agents are waiting for notifications from the server and are associated to human users. Moreover these agents are responsible to store localization information locally, when the connection to the main platform is unavailable, which can happen quite often on a loosely [1].

Only the android application is present on user's device and rest of processing will be at server side. The main output of the system's specification, that meets user carpooling needs

and the flow list of requirements, aiming to increase the average rate of car occupancy, is:

- Real time traffic information;
- Best route search based on traffic information, based on Dynamic route matching algorithms;
- Ad-hoc trip arrangements;
- Use of past-experience data to estimate time-to-pickup;
- User Profiles and credit mechanisms.
- Integration with public transportation information And parking facilities.

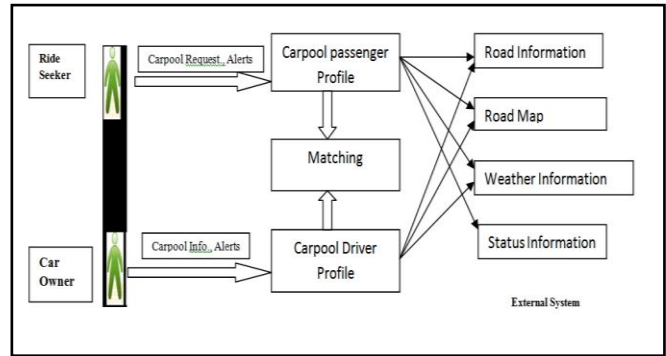

Fig. 3 System main modules

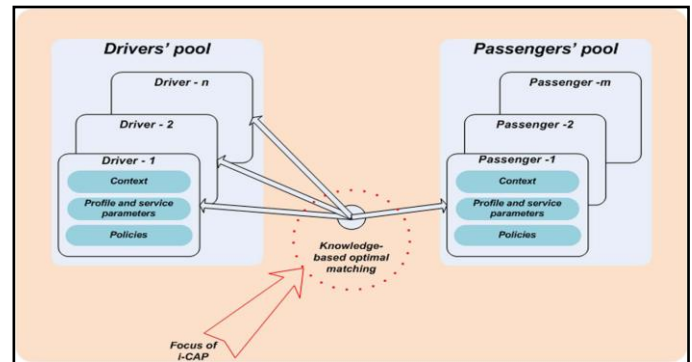

Fig. 4 Stakeholders Profile

Driver profile is illustrated on Figure 3 and 4: user login, password, mail, cellular phone number, starts and ends points, number of available seats, window travel time (date, start hour, end hour) [6].

The passenger profile is illustrated on Figure 3 and 4: user login, Password, mail, cellular phone number, window travel time, start and ends points, credits, user results preference like Driving distance to picking point, waiting time and if wants a daily updated information or relay on pre-defined information [6]. Results visualization can use a map using Google maps interface and can receive notification about delays of scheduled ride based on driver start hour delay (only possible if the driver alerts the system) or road traffic conditions.

There are three stakeholders Car owner, Ride seeker and the admin (For authentication purpose if the system is dedicated to particular organization only). It is compulsory for stakeholders to authenticate themselves before using the system. When the car owner leaves from home he sends a notification to all. At the ride seeker's side if he is interested to take a ride then he sends RIDE\_REQUEST to car owner. If the car owner

has empty seats then he can accept the request otherwise he can deny it. Car owner can also deny the RIDE\_REQUEST in case of security reasons. This approach is applicable if the car owner doesn't feel secure with the Ride seeker.

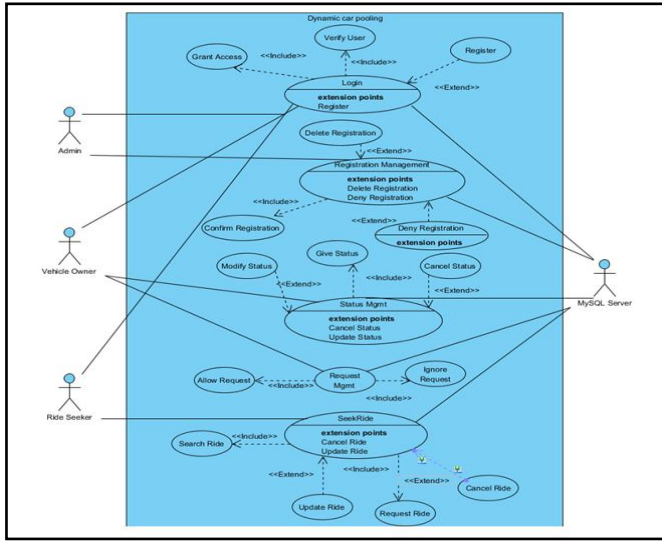

Fig. 5 Use Case diagram for Enable Dynamic Carpooling

### III. IMPLEMENTATION

#### A. Registration and Log In mechanisms

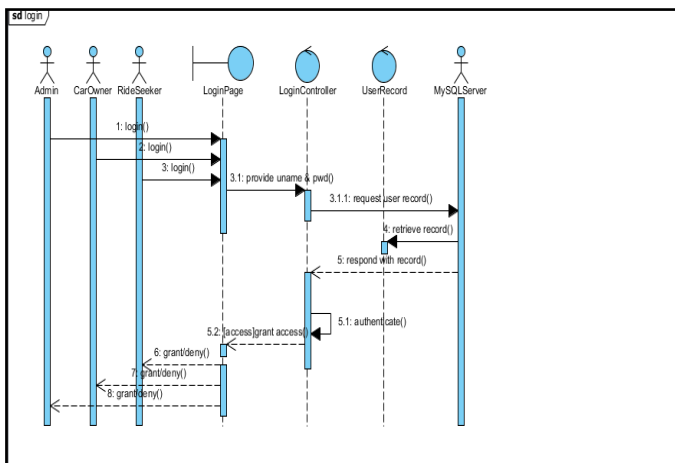
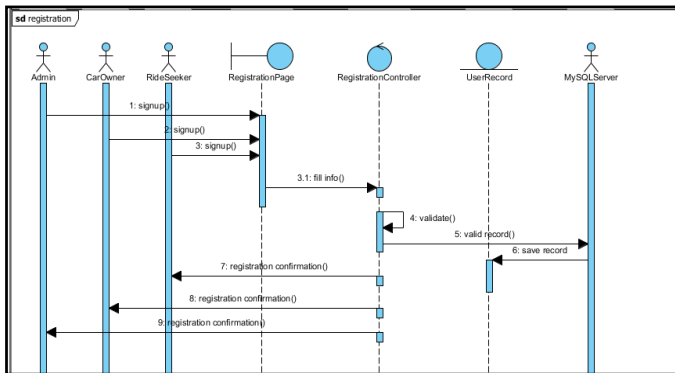

Fig.6 Registration and Log In procedures

#### B. Interaction of Stakeholders with the Server

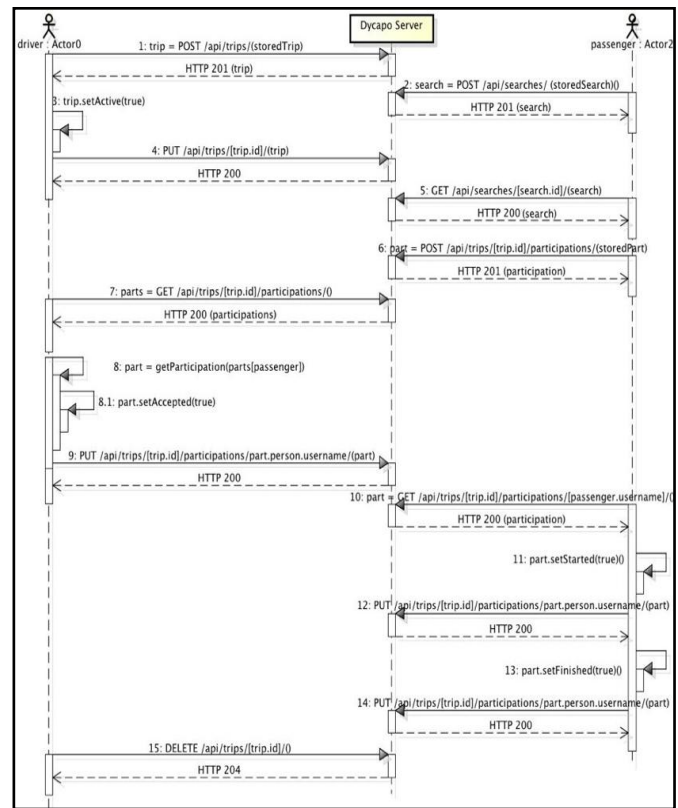

Fig.7 Stakeholders interaction with the Carpool Server

Dynamic carpooling Server is software built using first throwaway then evolutionary prototyping to demonstrate and support the definition of a standard protocol for dynamic carpooling. In this part we describe the software components, the enabling technologies, the models and the functionalities [9].

#### C. Class Diagram for Dynamic carpooling

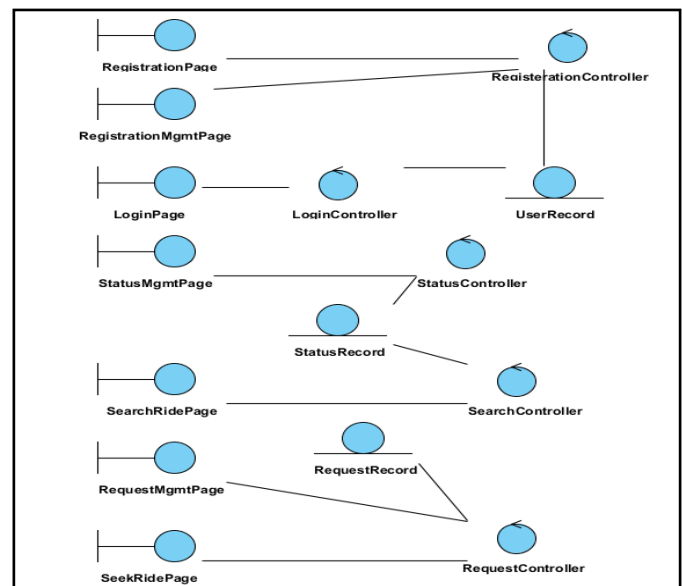

Fig.8 Class Diagram for Dynamic Carpooling

## D. Level-0 Data flow diagram for Dynamic Car pooling

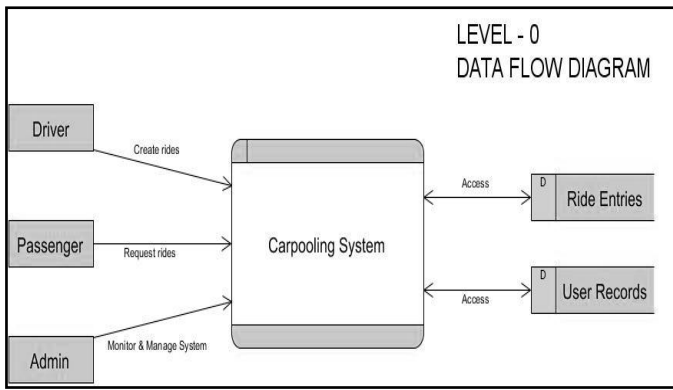

Fig. 9 Level-0 Data flow diagram for Dynamic Car pooling

## IV. MAJOR RIDESHARE CHALLENGES

- Social/Behavioral
  - “Stranger Danger”
  - Lack of Mutual Benefit
  - Service Reliability
  - Schedule Flexibility
  - Consistency of
  - Expectations
- Institutional
  - Public/Private Sector Roles
  - Business Model
- Economic
  - Little Incentive to Maximize Occupancy
  - Imperfect Information
  - High Transaction Costs
- Technological
  - Measuring Successful Trips
  - Common Database Specification.

## V. SOME ENABLING TECHNOLOGIES & FEATURES

- Enabling Technologies
  - Smart Phones
  - User-Friendly Interfaces - iPhone, Android (Apps)
  - Constant Data Network
  - Connections
  - GPS-Functionality
  - Ride Matching & Routing Algorithm
  - Database
- Features
  - Social Network Integration (Facebook, Institutions, twitter)
  - Stored User Profiles
  - Rideshare User Evaluation (eBay)
  - Automated Financial Transactions
  - Incentives / Loyalty
  - Rewards

## VI. CONCLUSION

This paper incorporates a novel approach for Dynamic Rideshare Matching Optimization model that is aimed at identifying suitable matches between passengers requesting rideshare services with appropriate drivers available to carpool for credits and HOV lane privileges. Server receives passengers and drivers information and preferences continuously over time and assigns passengers to drivers with respect to proximity in time and space and compatibility of characteristics and preferences among the passengers, drivers and passengers onboard.

## ACKNOWLEDGMENT

This work is supported by S.T.E.S.’s Sinhgad Academy of Engineering. We are thankful to Dr. A. G. Kharat, Principal, Col. Prof. O. P. Misra & Dr. C. B. Bangal, Vice Principal, Prof. A. N. Adapanawar, HOD-IT for their support and guidance.

We wish to express our sincere thanks to Mr. Kalyan Gunda, STSM, GPFS & SONAS Development IBM STG, Bangalore, India for his support and guidance.

## REFERENCES

- [1] Cédric Bonhomme, Gérald Arnould and Djamel Khadraoui Public Research Centre Henri Tudor 29 Avenue John F. Kennedy, L-1855, Luxembourg ffirstname.lastname@tudor.lu "Dynamic Carpooling Mobility Services based on Secure Multi-Agent Platform".
- [2] Blerim Ciciy?, Athina Markopoulouy, Enrique Frías-Martínez?, Nikolaos Laoutaris? UC Irviney, Telefonica Research(Spain)? {bcici, athina}@uci.edu, {efm, nikos}@tid.es . Quantifying the Potential of Ride-Sharing using Call Description Records.
- [3] Deepak B. Nagare, Kishor L. More, Nitin S. Tanwar, S.S.Kulkarni, Kalyan C. Gunda, “Dynamic Carpooling Application Development on Android Platform”, International Journal of Innovative Technology and Exploring Engineering (IJITEE) ISSN: 2278-3075, Volume-2, Issue-3, February 2013
- [4] The true cost of a car over its lifetime:http://www.doughroller.net/smart-spending/true-cost-of-a-car-over-its-lifetime.
- [5] Arpita Dixit, Shweta Bora, Sonali Chemate, Nikita Kolpekwar,Real-Time Carpooling System for Android Platform, International Journal of Engineering and Innovative Technology (IJEIT) Volume 2, Issue 6, December 2012.
- [6] George Dimitrakopoulos, Panagiotis Demestichas and Vera Koutra, "Intelligent Management Functionality for Improving Transportation Efficiency by Means of the Car Pooling Concept",IEEE TRANSACTIONS ON INTELLIGENT TRANSPORTATION SYSTEMS, VOL. 13, NO. 2, JUNE 2012
- [7] Marc Oliphant & Andrew Amey, "Dynamic Ridesharing: Carpooling Meets the Information Age", MIT "Real-Time" Rideshare Current Research: Andrew Amey amamey@alum.mit.edu, Future MIT Research & Collaboration: John Attanucci jattan@mit.edu.
- [8] Gérald Arnould, Djamel Khadraoui, Marcelo Armendáriz, Juan C. Burguillo, Ana Peleteiro, "A Transport Based Clearing System for Dynamic Carpooling Business Services", 2011 11th International Conference on ITS Telecommunications.
- [9] Daniel Graziotin, "Dycapo: On the creation of an open-source Server and a Protocol for Dynamic Carpooling", Free University of Bolzano.
- [10] G. Arnould, D. Khadraoui, M. Armendáriz, J. C. Burguillo, and A. Peleteiro, "Mobile and vehicular communication optimization and simulation in the context of a dynamic carpooling subsystem," in Int. J. Signal and Imaging Systems Engineering, vol. 1, no. 3/4, 2011.
- [11] Shangyao Yan, Chun-Ying Chen, and Yu-Fang Lin, "A Model with a Heuristic Algorithm for Solving the Long-Term Many-to-Many Carpooling Problem", IEEE TRANSACTIONS ON INTELLIGENT TRANSPORTATION SYSTEMS, VOL. 12, NO. 4, DECEMBER 2011.



**Shreeram S. Kulkarni**, Assistant Professor, Department of Information Technology, S.T.E.S.'s Sinhgad Academy of Engineering, Pune, India, Pursuing Ph.D in E&TC from university of Pune. ME [E&TC], BE [INSTRU.], Published 4 papers in various National Journals & Conferences. Also published 2 books for Engineering & Technology.  
[kulk.shri@gmail.com](mailto:kulk.shri@gmail.com)



**Deepak Nagare**, B. E. Information Technology student, Department of Information Technology, S.T.E.S.'s Sinhgad Academy of Engineering, Pune, India.  
[deep.nagare@gmail.com](mailto:deep.nagare@gmail.com)



**Kishor More**, B. E. Information Technology student, Department of Information Technology, S.T.E.S.'s Sinhgad Academy of Engineering, Pune, India.  
[kishormore.pc@gmail.com](mailto:kishormore.pc@gmail.com)



**Nitin Singh Tanwar**, B. E. Information Technology student, Department of Information Technology, S.T.E.S.'s Sinhgad Academy of Engineering, Pune, India.  
[nitinrocksit@gmail.com](mailto:nitinrocksit@gmail.com)